

Fisher™ DFA Variable Geometry Desuperheater

The Fisher DFA (Desuperheater with Flexible Architecture) can be used in many applications to efficiently control the spraywater and reduce the temperature of superheated steam to the desired set point. The valve is available with a wide range of standard and anti-cavitation trim styles. The desuperheater is mechanically atomized with a variable geometry nozzle. Desuperheaters are available for installation in steam lines from DN200 through DN1500 (NPS 8 through 60) in diameter and are capable of maintaining steam temperatures to within 6°C (10°F) of saturation temperatures.

- DFA—The Fisher DFA desuperheater's flexible architecture incorporates both a water control element and a variable-geometry mechanically atomized, self-contained desuperheater for moderate to high flow variation. It is installed through a flanged connection on the side of an NPS 8 or larger pipeline.

This unit offers separate desuperheating and spray water control elements packaged together to match many of the standard face-to-face dimensions offered in today's marketplace. The angle body can be offered to match most ASME pressure classes with either BWE or Flanged configurations. Multiple trim configurations can be offered and include equal percentage, linear, anti-cavitation micro-flat, Cavitrol™ III, and multi-stage micro-flat trim styles.

The desuperheater is a variation of the DMA/AF-HTC. This device can be used in less severe applications, such as temperature control to paper machines to more severe applications such as boiler interstage attemperation.

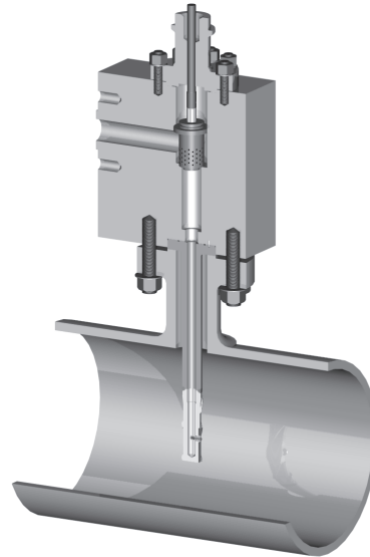

DFA Construction Includes Valve Body, Trim, and Insertion Style Desuperheater (pipe not included)

Similar to the DMA/AF-HTC, the DFA uses a construction optimized to move weld joints away from high stress regions.

The desuperheater design incorporates an integral thermal liner inside the desuperheater body pipe. This minimizes the potential for thermal shock when cool water is introduced to the unit that is already heated to the operating steam temperature.

The nozzle mount for the DFA shares vortex suppressor geometry with the DMA/AF-HTC, which is engineered to minimize the potential for excitation due to vortex shedding and flow induced vibration.

The desuperheater (figure 2) is installed through a flanged connection on a DN200 (NPS 8) or larger pipeline. Maximum nozzle Cv is 15.0.

Specifications

Available Configurations⁽¹⁾ and Valve Sizes

■ DFA valve body style: Angle

Common Characteristics: Designed according to ASME B16.34 Valve-Flanges, Threaded and Welding End

End Connections Styles⁽¹⁾

See tables 1 and 2

Maximum Inlet Pressure and Temperature^(1,2)

Flanged, Socketwelding, or Buttwelding: Consistent with CL150, 300, 600, 900, 1500, and 2500 according to ASME B16.34, unless limited by maximum pressure drop or material temperature capabilities

Maximum Pressure Drop⁽¹⁾

Valve with Cavitrol III Cage: 149 bar (2160 psi) for two-stage and 207 bar (3000 psi) for three-stage cage. Consult bulletin [80.2:030, Fisher Cavitrol III One-, Two-, and Three-Stage trims \(D100196X012\)](#), for more information

Anti-cavitation MicroFlat: <51.7 bard (<750 psid)

Inherent Rangeability

Up to 50:1. The ratio of maximum to minimum controllable C_v is dependent upon the available water pressure differential

Spray Water Pressure Required⁽³⁾

6.9 bar (100 psi) above steam pressure

Shutoff Classifications per ANSI/FCI 70-2 and IEC 60534-4

Class V only

Construction Materials

Valve Body and Bonnet:

■ SA105, ■ F22 Cr-Mo steel, ■ F91 chrome-moly alloy

Trim: See table 4

Other Parts: See table 3

Consult your [Emerson Process Management sales office](#) for special trim and valve body material availability.

Desuperheater Body (DFA): ■ Chrome-moly alloy steel (F22, F91), or ■ Carbon Steel (SA105)

Note: Will have body-matched cast equivalent material for nozzle mount

Nozzle Material

■ 410 stainless steel

Valve Body Material

■ Chrome-moly alloy steel (F22, F91) or ■ Carbon Steel (SA105)

Material Temperature Capabilities⁽¹⁾

See table 3

Flow Characteristics⁽⁴⁾

Standard Cages: ■ Linear, ■ equal percentage, ■ modified equal percentage⁽⁵⁾

Cavitrol III: Linear

Micro-Flat (with or without liner): Linear

Flow Direction

All: Flow down

Flow Coefficients

See table 8 and also Fisher Catalog 12

Port Diameters, Valve Plug Travel, and Stem Diameters

See table 8

Bonnet Style and Mounting⁽¹⁾

Standard Bonnet

Yoke Temperature Limit: Standard bonnet with cast iron yoke is limited to 537°C (1000°F)

Packing Arrangements

■ Single, ■ Double, and ■ Leakoff standard graphite packing, or optional ■ ENVIRO-SEAL™ and

■ HIGH-SEAL packing systems. See bulletin [59.1:061, Fisher ENVIRO-SEAL and HIGH-SEAL Packing System for Sliding-Stem Valves \(Live-Loaded\), D101633X012](#)

Approximate Weight

See table 9

1. Do not exceed the pressure or temperature limits in this bulletin, nor any applicable code or standard limitations.
 2. EN (or other valve body material) ratings and end connections can usually be supplied; consult your Emerson Process Management sales office.
 3. A function of required turndown and equipment selection.
 4. Special characterized cages are available. Contact your Emerson Process Management sales office.
 5. Modified equal percentage characteristic is equal percentage for the first 75% of travel, then opens quickly for additional capacity.



Table 1. Desuperheater Connection Size

Design	Steam Line Size, NPS	Steam Line Connection	
		Size, NPS	ASME Pressure Rating Raised-Face Flange(1)
DFA	8 - 60	3 or 4	CL150-2500

1. Other standard flanges and connections are also available.

Table 2. Available Valve Connections

Valve Inlet Size, NPS	ASME Pressure Rating Raised-Face Flange(2)	Connection	
		Inlet ^(1,2,3)	Outlet ^(1,2)
1, 1-1/2, and 2	CL150-2500	RF, RTJ, BW, and SW	RF

1. End connection style abbreviations: RF-Raised Face, RTJ-Ring Type Joint, BW-Butt weld, SW-Socket Weld.

2. EN (or other valve body material) ratings and end connections can usually be supplied; consult your [Emerson Process Management sales office](#).

3. Socket weld available on NPS 1, 1-1/2, and 2 only.

Features

- **Valve Plug Stability**-- Rugged seat guided and cage guiding provides increased valve plug stability, which reduces vibration and mechanical noise.
- **Full Pressure Drop Capability**-- Rugged construction allows full pressure drop capability.
- **Piping Economy**-- Face-to-face dimensions conveniently match other common dimensions currently on the market.
- **Quick Change Trim**-- Maintenance is simple and can easily be performed using common tools. Trim components can be quickly removed and changed with no need for special tools.
- **Cost-Effective Operation and Maintenance Economy**--Increased wear resistance of hardened stainless steel trim means longer-lasting service. When inspection or maintenance is necessary, the body can stay in the pipeline during removal of trim parts. And, trim inventory costs are cut because dimensional standardization permits use of most standard easy-e™ or HP trim parts.
- **Flexible Architecture**--Custom designed bodies with a probe-style desuperheater, matched with multiple trim styles, to meet almost any face-to-face, piping, or application requirements.
- **Accurate Temperature Control Near Saturation**-- Optimized spray pattern with AF nozzle technology allows for a wide operating range to achieve optimal mixing and quick vaporization at all flowing conditions.
- **Costly Maintenance Avoidance and Short Turnarounds**-- Nozzles can be easily removed, maintained, or replaced without having to replace the entire unit.
- **Cracked Weld Avoidance**-- DFA desuperheater uses a forged construction, optimized to move weld joints away from high stress regions.
- **Managing Large Temperature Changes**-- Nozzles in multiple configurations capable of providing large amounts of spraywater to cool steam to required temperature.
- **Thermal Cycling**-- The desuperheater design incorporates an integral thermal liner inside the desuperheater body pipe to minimize the potential for thermal shock when cool water is introduced.
- **Minimize Vibration-Related Failures**-- The nozzle mount for the Fisher DFA desuperheater is engineered to minimize the potential for excitation due to vortex shedding and flow induced vibration.

Table 3. Fisher DFA Construction Materials and Temperature Capabilities for Parts Other than Valve Body and Trim

PART	MATERIAL	TEMPERATURE CAPABILITIES	
		°C	°F
Valve plug stem	S20910	-198 to 593	-325 to 1100
Spring-loaded valve plug seal	Backup ring	S41600 (416 SST)	-29 to 427
		S31600 (316 SST)	-198 to 593
	Retaining ring	S30200 (302 SST)	-254 to 593
	Seal ring	PTFE with N10276 Spring	-73 to 232 ⁽²⁾
	Anti-extrusion rings	PEEK (PolyEtherEtherKetone)	-73 to 316
Cage gasket	N06600/Graphite	-240 to 593	-400 to 1100
Seat ring gasket	Flexible Graphite (standard), CL150 to CL600 N06600/Graphite, CL900 to CL2500	-240 to 593	-400 to 1100
Valve Body-to-bonnet bolting ⁽¹⁾	Studs	Steel SA193-B7 (all valve body materials)	-29 to 427
	Nuts	Steel SA194-2H (all valve body materials)	-29 to 427
	Studs	Steel SA193-B16 (F91 valve body mat'ls)	-29 to 482 ⁽³⁾
	Nuts	Steel SA194-7	-29 to 510
	Studs	Steel SA193-B16 (F22 valve body mat'l CL600 and below)	-29 to 566
	Studs	Steel SA193-B16 (F22 valve body mat'l CL900 and above)	-29 to 510
	Nuts	Steel SA194-7	-29 to 566
	Nuts	N07718 SST (SB637)	-29 to 593 (F22)
	Steel SA194-7	-29 to 593 (F91)	
Packing	Graphite	-198 to 538 ⁽⁴⁾	-325 to 1000 ⁽⁴⁾
Packing follower, spring, or lantern ring	S31600 stainless steel	-254 to 593	-425 to 1100
Packing box ring	S31600 stainless steel	-254 to 593	-425 to 1100
Packing flange, studs, or nuts	Steel	-29 to 427	-20 to 800
	S31600 stainless steel	-198 to 593	-325 to 1100

1. Valve body materials with which these bolting materials may be used are shown in parentheses.
 2. If used with PEEK anti-extrusion rings, PTFE/carbon seal ring may be used in temperatures up to 316°C (600°F) for non-oxidizing service or up to 260°C (500°F) for oxidizing service.
 3. B16 studs are rated to 510°C (950°F) for NPS 1 CL300, NPS 2 CL600, and all NPS CL900 and above.
 4. Except 371°C (700°F) for oxidizing service.

Table 4. Fisher DFA Trim Material Combinations

TRIM	VALVE BODY MATERIALS	PRESSURE CLASS AVAILABILITY (1)	VALVE PLUG	CAGE	SEAT RING	STEAM DESIGN TEMPERATURE RANGE			
						°C		°F	
						Min	Max	Min	Max
Standard Plug and Cage									
291	SA105, F22 and F91	CL150-CL2500	S41600	CB7Cu-1 H1075	S41600	-29	427	-20	800
292A	F22 and F91	CL150-CL600	S31600 with CoCr-A seat and guide	R30006	R30006	427	593	800	1100
292B	F22	CL900-CL2500	S31600 with CoCr-A seat and guide	F22/Nitrided	S31600/CoCr-A	427	593	800	1100
292C	F91 only	CL900-CL2500	F91 with CoCr-A Seat and guide	F91/Nitrided	F91 with CoCr-A	427	593	800	1100
Standard Cage, Anti-Cav Micro-Flat Plug									
293	SA105, F22 and F91	CL150-CL2500	S44004	17-4 PH H1075	S44004	-29	427	-20	800
294A	F22	CL150-CL2500	410 SST with R30016 tip	F22/Nitride	R30006	427	593	800	1100
294B	F91 only	CL150-CL2500	410 SST with R30016 tip	F91/Nitride	R30006	427	593	800	1100
Cavitrol III Cage, Standard Plug									
295B ⁽²⁾	SA105, F22 and F91	CL150-CL600	420SST	17-4 H1075	17-4 H900	-29	427	-20	800
295A	SA105, F22 and F91	CL900-CL2500	S44004	17-4 H1075	S44004	-29	343	-20	650
296	SA105, F22 and F91	CL150-CL2500	410 / CoCr-A Seat & Guide	422/Nitrided	410 / CoCr-A	427	593	650	1100
Cavitrol III Cage, Micro-Flat Plug⁽²⁾									
295A	SA105, F22 and F91	CL150-CL2500	S44004	17-4 H1075	S44004	-29	343	-20	650
297	F22 and F91	CL150-CL2500	410 SST with R30016 tip	422/Nitrided	R30006	427	593	650	1100

1. Pressure class at the inlet to the water control valve.
2. Consult your [Emerson Process Management sales office](#) for these trim options.

Principle of Operation

For the most efficient use of heat energy from steam, it is necessary to reduce the temperature of steam to near the saturation temperature. With steam that is at or near the saturation temperature, it is possible to recover the large amount of energy that was put into the steam when it was heated from water to steam. Desuperheating, or attemperation as it is sometimes called, is most often used to • improve thermal efficiency of heat transfer processes by using steam near saturation, • control unintentional superheat from pressure reduction of the steam, and • protect downstream equipment and piping from elevated temperatures and pressure.

DFA desuperheaters produce a spray of cooling water in a steam line (figure 2). The spraywater cools the steam to near the saturation temperature or to a custom setpoint. The rate of cooling is dependent on spraywater droplet size, distribution, flow turbulence of the steam, and velocity. The temperature is controlled by varying the amount of spraywater flow.

The desuperheater utilizes the proven, spring-loaded AF (Anti-Flash) nozzle to provide a uniform hollow cone spray pattern over a wide range of flow conditions. The water is injected through holes drilled at a compound angle to induce spin as the AF nozzle plug is opened with increasing water pressure. The design of the AF nozzle is such that water flows only after sufficient backpressure is available to provide a good spray pattern. The full opening of the AF nozzle is limited by a travel stop to keep the spring within its proper working range and to maintain the water film thickness at the necessary thickness for proper atomization.

Figure 1. Fisher DFA Desuperheater

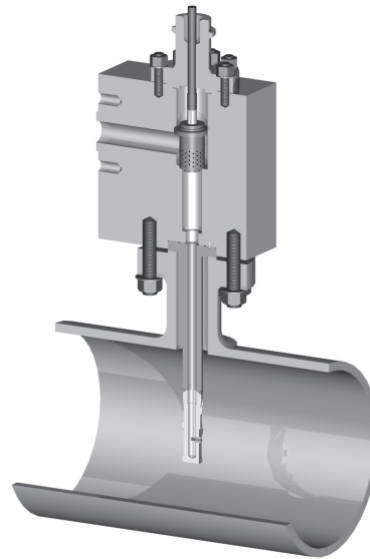

In operation, spraywater is supplied to a connection on the desuperheater. The body, trim, insertion length, and face-to-face can be custom engineered for specific needs. This offers convenient replacement of common products on the market today without the need for piping modifications.

Figure 2. Typical DFA Installation

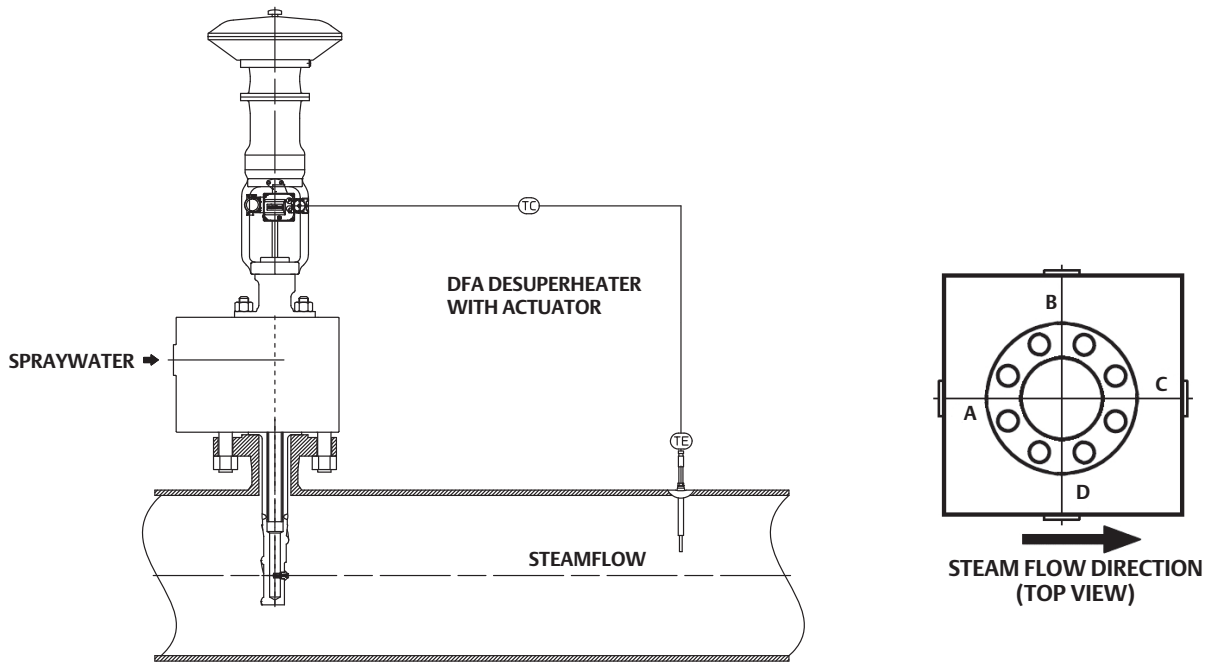

Ordering Information

When ordering, specify the following information. Items 1 through 6 are required for desuperheater sizing.

1. Maximum, normal, and minimum steam flow rate.
2. Steam pressure and temperature at the inlet and outlet.
3. Spraywater pressure and temperature.
4. Design conditions, if different from operating conditions.
5. Steam line size.
6. Desuperheater steam connection size, type, and rating.
7. Spraywater connection size from table 1.
8. Face-to-face dimension (if replacing existing unit).
9. Water flange orientation.

Figure 3. Fisher DFA Desuperheater Dimensions (also see tables 5 and 6)

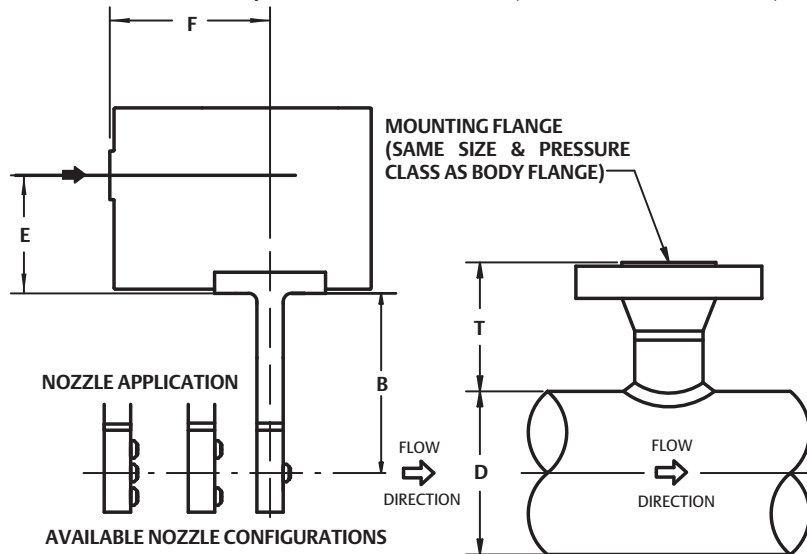

Table 5. Fisher DFA Desuperheater Dimensions

DESUPERHEATER BODY FLANGE ⁽¹⁾		E INLET CENTERLINE TO OUTLET FLANGE FACE ⁽²⁾		F INLET FLANGE FACE TO OUTLET CENTERLINE ⁽²⁾	
Size, NPS	Pressure Rating	mm	Inches	mm	Inches
3 and 4	CL150-1500	152	6	229	9
	CL2500	178	7	241	9.5

1. The NPS 4 DFA requires a 4.00 inch minimum mounting I.D. Contact your [Emerson Process Management sales office](#) for NPS 3 DFA minimum mounting I.D.
2. For different centerline to flange face distances Contact your Emerson Process Management sales office.

Table 6. Fisher DFA Desuperheater Installation Dimensions

DESUPERHEATER BODY FLANGE SIZE, NPS	("D" DIMENSION) PIPE LINE	("B" DIMENSION) INSERTION LENGTH		("T" DIMENSION) T-HEIGHT	
	Size, NPS	mm	Inch	mm	Inch
3 and 4	8	330	13.00	222	8.75
	10	362	14.25	222	8.75
	12	387	15.25	222	8.75
	14	400	15.75	222	8.75
	16	425	16.75	222	8.75
	18	445	17.50	216	8.50
	20	451	17.75	222	8.75
	22	451	17.75	222	8.75
	24, 26, 28	451	17.75	222	8.75
30 or larger	448	17.63	219	8.63	

Table 7. Fisher DFA Desuperheater Minimum Mounting I.D.

MINIMUM BODY FLANGE	NOZZLE MODEL	MINIMUM MOUNTING I.D.
3	DFA- A,B,C	2.624
3	DFA- D, E	2.9
4	DFA- A through H	4

Table 8. Typical Valve Flow Coefficients⁽¹⁾ - Flow Down (without Liner)

WATER CLASS	VALVE TRIM SIZE, NPS	TRIM TYPE	CHARACTERISTIC (2,3)	PORT		TRAVEL		MAXIMUM C _v			
				mm	inch	mm	inch				
CL150-600	1, 1 1/2	Standard	Equal Percentage	33.3	1.3125	19.1	0.75	19			
			Linear	33.3	1.3125			22.3			
		M-Flat	Linear		6.3	0.25	19.1	0.75	0.292		
					9.5	0.375			0.873		
					12.7	0.5			1.76		
					19.1	0.75			3.38		
				19.1	0.75	4.46					
	2	Standard	Equal Percentage		33.3	1.3125	19.1	0.75	26.8		
					47.6	1.875			47.2		
			Linear		33.3	1.3125			37.6		
					47.6	1.875			52.5		
		M-Flat	Linear		6.3	0.25	19.1	0.75	0.292		
					9.5	0.375			0.873		
					12.7	0.5			1.76		
					19.1	0.75			3.38		
					19.1	0.75			4.46		
					25.4	1			7.81		
					28.6	1.125			10.49		
CL900-1500	1, 1 1/2	Standard	Modified Equal Percentage	19.1	0.75	28.6	1.125	10.7			
			Equal Percentage	19.1	0.75	19.1	0.75	5.58			
		Cavitrol III 2-Stage	Linear	22.2	0.875	38.1	1.5	7.39			
		Micro-Flat	Linear		9.5	0.375	19.1	0.75	0.961		
					12.7	0.5			1.71		
					19.1	0.75			2.92		
	2	Standard	Modified Equal Percentage		19.1	0.75	28.6	1.125	10.7		
					25.4	1			21		
					31.8	1.25			31		
			Equal Percentage		38.1	1.5			38.1	1.5	48
					19.1	0.75			19.1	0.75	5.58
					25.4	1					9.5
			31.8	1.25	13						
			38.1	1.5	28.6	1.125	35				
		Cavitrol III 2-Stage	Linear	44.4	1.75	50.8	2	14			
Cavitrol III 3-Stage	Linear	25.4	1	50.8	2	6.73					
Micro-Flat	Linear	25.4	1	28.6	1.125	7.61					

-continued-

Table 8. Typical Valve Flow Coefficients⁽¹⁾ - Flow Down (without Liner) (continued)

WATER CLASS	VALVE TRIM SIZE, NPS	TRIM TYPE	CHARACTERISTIC (2,3)	PORT		TRAVEL		MAXIMUM C _v
				mm	inch	mm	inch	
CL2500	1, 1 1/2	Standard	Modified Equal Percentage	19.1	0.75	28.6	1.125	9.73
			Equal Percentage	19.1	0.75	19.1	0.75	5.38
		Cavitrol III 2-Stage	Linear	22.2	0.875	38.1	1.5	6.91
		Micro-Flat	Linear	9.5	0.375	19.1	0.75	0.961
				12.7	0.5			1.71
				19.1	0.75			2.92
	2	Standard	Modified Equal Percentage	19.1	0.75	28.6	1.125	10.7
				25.4	1			21
				31.8	1.25			31
			Equal Percentage	38.1	1.5	38.1	1.5	36.8
				19.1	0.75	19.1	0.75	5.58
				25.4	1			9.5
		31.8	1.25	13				
		38.1	1.5	28.6	1.125	31.5		
		Cavitrol III 2-Stage	Linear	44.4	1.75	50.8	2	14
		Cavitrol III 3-Stage	Linear	25.4	1	50.8	2	6.73
		Micro-Flat	Linear	25.4	1	28.6	1.125	7.61

1. See Catalog 12 for a complete listing of flow coefficients.
 2. Characteristic is equal percentage through 75% of travel.
 3. Micro-Flat Anti-Cavitation trims use a shutoff port diameter which is 0.125 inch larger than the flowing port diameter. Use the shutoff port diameter for actuator sizing

Table 9. Fisher DFA Weights⁽¹⁾

OUTLET CONNECTION	INLET CONNECTION	CLASS	APPROXIMATE WEIGHT	
			kg	lbs
3	1	600	128	283
		1500	183	403
		2500	253	558
	1-1/2	600	137	301
		1500	193	426
		2500	273	602
	2	600	138	304
		1500	206	454
		2500	287	633
4	1	600	179	394
		1500	224	494
		2500	312	688
	1-1/2	600	191	420
		1500	237	522
		2500	337	743
	2	600	193	425
		1500	253	558
		2500	354	781

1. Desuperheater section weighs about 11.4 kg (25 lbs).

Product Bulletin

85.2:DFA
March 2016

DFA Desuperheater
D103619X012

Neither Emerson, Emerson Process Management, nor any of their affiliated entities assumes responsibility for the selection, use or maintenance of any product. Responsibility for proper selection, use, and maintenance of any product remains solely with the purchaser and end user.

Fisher, Cavitrol, ENVIRO-SEAL, and easy-e are marks owned by one of the companies in the Emerson Process Management business unit of Emerson Electric Co. Emerson Process Management, Emerson, and the Emerson logo are trademarks and service marks of Emerson Electric Co. All other marks are the property of their respective owners.

The contents of this publication are presented for informational purposes only, and while every effort has been made to ensure their accuracy, they are not to be construed as warranties or guarantees, express or implied, regarding the products or services described herein or their use or applicability. All sales are governed by our terms and conditions, which are available upon request. We reserve the right to modify or improve the designs or specifications of such products at any time without notice.

Emerson Process Management
Marshalltown, Iowa 50158 USA
Sorocaba, 18087 Brazil
Cernay, 68700 France
Dubai, United Arab Emirates
Singapore 128461 Singapore

www.Fisher.com