

M Series Manual Handwheel Gear Actuators for Fisher® Butterfly Valves

M Series handwheel gear actuators are totally enclosed, weatherproof, worm gear actuators for reliable manual operation with Fisher A11, A31A, A41, and 8560 High Performance Butterfly Valves. The M Series actuator consists of a body housing, cover, worm gear, input shaft, and handwheel. The housing is grease-packed.

Features

- **Long Service Life**—Rugged construction provides stability and corrosion resistance. The unit is totally enclosed for weatherproof operation.
- **Accurate Valve Disk Positioning**—Two adjustable stops are located in the housing for correct adjustment of disk position. The actuator is inherently self-locking, unless subjected to high vibration.
- **Overtravel Capability**—Provides for five degrees of overtravel in both directions for precise positioning of the valve disk.

Installation

The M Series gear actuator is normally mounted on a valve at the factory. However, the actuator can be field-mounted; it can be mounted in any position on the A11 or A31A and it can be mounted in positions 1 and 3 on the A41 and 8560, as shown in figure 1. Make clearance considerations before mounting the actuator to determine the most suitable mounting position. Dimensions are shown in figure 2.



W4715-1

M SERIES HANDWHEEL GEAR ACTUATOR



Specifications

Actuator Sizes

See tables 1, 2, and 3

Valve Compatibility

- Accepts A11 valve square-end shafts from 10.3 to 34.9 mm (0.405 to 1.375 inches), keyed shafts from 38.1 to 44.5 mm (1-1/2 to 1-3/4 inches)⁽¹⁾
- Accepts A31A valve keyed shafts from 44.5 to 57.2 mm (1-3/4 to 2-1/4 inches)
- Accepts A41 and 8560 valves Double D shafts from 12.7 to 44.5 mm (1/2 to 1-3/4 inches)

See tables 1, 2, and 3

Maximum Torque Output

See tables 1, 2, and 3

Handwheel Rotation

Clockwise handwheel rotation closes the valve (produces clockwise rotation of the valve shaft)

Construction Materials

- Housing and Cover: Cast iron
- Worm: Steel
- Worm Gear: Manganese Bronze
- Input Shaft: Steel (S30300 on request)
- Handwheel: Cast Iron

Mounting Positions

See figure 1

Approximate Weight without Handwheel

ACTUATOR	A11		A31A	
	WEIGHT			
	kg	lb	kg	lb
1KE	7.3	16	5.4	12
2KE	10	22	8.6	19
5KE	12.2	27	10	22
7KE	22.6	50	20.4	45
9KE	31.8	70	31.8	70
10KE	56.7	125	56.7	125

ACTUATOR	WEIGHT	
	kg	lb
0KE/D1, D2, D3, D1A, D2A, D3A	2.7	6
2KE/D4, D4A	8.2	18
6KE/D5, D6, D5A, D6A	13.6	30
9KF/D7	29.5	65

Handwheel Weight

- 8-inch: 2.0 kg (4.50 lb)
- 12-inch: 4.0 kg (6.75 lb)
- 18-inch: 4.5 kg (10 lb)
- 24-inch: 5.4 kg (12 lb)
- 36-inch: 7.8 kg (17.25 lb)

Dimensions

See figures 2

Options

- Locking plates with padlock for fixed positioning
- Stops are typically set every 10 degrees, but can be special ordered with stops set up to 45 degrees from both ends.
- Handwheel extensions

1. As an option, CL600 NPS 10 (with 1-1/2 inch keyed shaft) and NPS 12 (with 1-3/4 inch shaft) A11 valves require a keyed connection if being used with size 9KE or 10KE-6 actuators.

Table 1. M Series Gear Actuator for A11 (CL600)

VALVE SIZE, NPS	VALVE SHAFT SIZE, INCHES	MAXIMUM RECOMMENDED TORQUE ⁽¹⁾		ACTUATOR SIZE	HANDWHEEL DIAMETER, INCHES	RIM FORCE ⁽²⁾		NUMBER OF TURNS TO CLOSE ⁽³⁾	MAXIMUM TORQUE RATING OF ACTUATOR	
		N•m	lbf•in			N	lbf		N•m	lbf•in
3	13/32	113	1000 ⁽⁴⁾	1KE	12	80	18	9.5	452	4000
4	5/8	303	2690 ⁽⁴⁾	1KE	12	209	47	9.5	452	4000
6	7/8	643	5700	2KE	12	445	100	9.5	678	6000
		765	6780 ⁽⁴⁾	5KE		400	90	12.5	904	8000
8	1	643	5700	2KE	12	445	100	9.5	678	6000
		846	7500	5KE	12	445	100	12.5	904	8000
		1349	11960 ⁽⁴⁾	7KE	18	436	98	13.5	2260	20000
10	1-3/8	1354	12000	7KE	18	440	99	13.5	2260	20000
	1-1/2	2144	19000	9KE	24	440	99	16	3390	30000
	1-1/2	3520	31160 ⁽⁴⁾	10KE-6	18	214	48	72	8474	75000
12	1-3/8	1354	12000	7KE	18	440	99	13.5	2260	20000
	1-3/4	2144	19000	9KE	24	440	99	16	3390	30000
	1-3/4	3520	31160 ⁽⁴⁾	10KE-6	18	214	48	72	8474	75000

1. Maximum recommended torque for the valve/actuator combination is based on valve shaft rating, actuator rating and rim force.
2. Rim force required to produce Maximum recommended torque.
3. This column shows the number of times the handwheel must be turned to close the valve 90 degrees.
4. Shaft rating of the A11 valve.

Ordering Information

Because the M Series actuators for the A11 and A31A valves are often available in more than one size for any given valve size, they should be chosen according to torque requirements of the valve. Please specify

actuator size when specifying valve size and class.

M Series actuators for the A41 and 8560 valves have been matched to the requirements of each valve size and should be chosen according to the valve size requested.

Table 2. M Series Gear Actuator for A31A

VALVE SIZE, NPS	VALVE SHAFT SIZE, INCHES	MAXIMUM RECOMMENDED TORQUE ⁽¹⁾		ACTUATOR SIZE	HANDWHEEL DIAMETER, INCHES	RIM FORCE ⁽²⁾		NUMBER OF TURNS TO CLOSE ⁽³⁾	MAXIMUM TORQUE RATING OF ACTUATOR	
		N•m	lbf•in			N	lbf		N•m	lbf•in
CL150										
14	1-3/16	644	5700	2KE	12	445	100	9.5	271	6000
		847	7500	5KE	12	445	100	12.5	904	8000
		1287	11390 ⁽⁴⁾	7KE	18	418	94	13.5	2260	20000
16	1-1/4	644	5700	2KE	12	445	100	9.5	271	6000
		847	7500	5KE	12	445	100	12.5	904	8000
		1,579	13970 ⁽⁴⁾	7KE	18	512	115	13.5	2260	20000
18	1-1/2	1356	12000	7KE	18	440	99	13.5	2260	20000
		2188	19370 ⁽⁴⁾	9KE	24	449	101	16	3390	30000
		2188	19370	10KE-6	18	133	30	72	8474	75000
20	1-3/4	1356	12000	7KE	18	440	99	13.5	2260	20000
		2147	19000	9KE	24	440	99	16	3390	30000
		2555	22620 ⁽⁴⁾	10KE-6	18	156	35	72	8474	75000
24	2-1/4	2147	19000	9KE	24	440	99	16	3390	30000
		8,474	75000	10KE-6	18	516	116	72	8474	75000
CL300										
14	1-3/4	1356	12000	7KE	18	440	99	13.5	2260	20000
		2555	22620 ⁽⁴⁾	9KE	24	525	118	16	3390	30000
16	1-3/4	1356	12000	7KE	18	440	99	13.5	2260	20000
		2555	22620 ⁽⁴⁾	9KE	24	525	118	16	3390	30000
18	2-1/4	2147	19000	9KE	24	440	99	16	3390	30000
		6,985	61830 ⁽⁴⁾	10KE-6	18	423	95	72	8474	75000
20	2-3/4	2147	19000	9KE	24	440	99	16	3390	30000
		8474	75000	10KE-6	18	516	116	1672	8474	75000
24	2-3/4	8474	75000	10KE-6	18	516	116	72	8474	75000

1. Maximum recommended torque for the valve/actuator combination is based on valve shaft rating, actuator rating and rim force.
2. Rim force required to produce Maximum recommended torque.
3. This column shows the number of times the handwheel must be turned to close the valve 90 degrees.
4. Shaft rating of the A31A valve.

Table 3. M Series Gear Actuator for A41 and 8560

VALVE SHAFT SIZE, INCHES	ACTUATOR SIZE	SHAFT RATING		HANDWHEEL DIAMETER, INCHES	RIM FORCE ⁽¹⁾		NUMBER OF TURNS TO CLOSE ⁽²⁾	MAXIMUM TORQUE RATING OF ACTUATOR	
		N•m	lbf•in		N	lbf		N•m	lbf•in
1/2	0KE/D1	58	515	8	441	21	6	271	2400
5/8	0KE/D2	138	1230	8	227	51			
3/4	0KE/D3	240	2120	8	391	88			
1	2KE/D4	468	4140	12	325	73	9.5	678	6000
1-1/4	6KE/D5	1110	9820	24	365	82	10	1356	12000
1-1/2	6KE/D6	1356	12000	24	445	100			
1-3/4	9KE/D7	2658	23520	36	365	82	16	3390	30000

1. Rim force required to produce shaft rating torque.
2. This column shows the number of times the handwheel must be turned to close the valve 90 degrees.

Figure 1. Available Mounting Positions

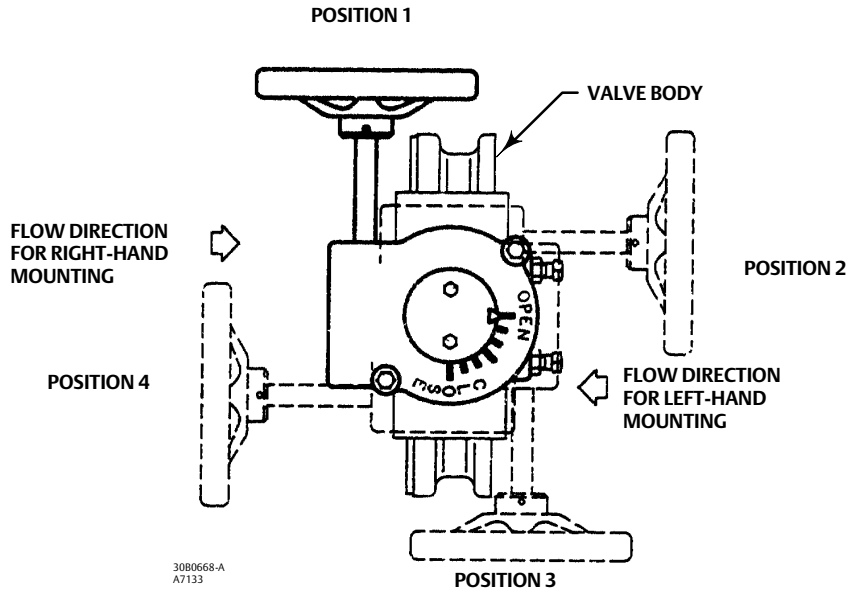

Note: Only positions 1 and 3 are applicable to A41 and 8560.

Figure 2. M Series Dimensions (also see tables 4 and 5)

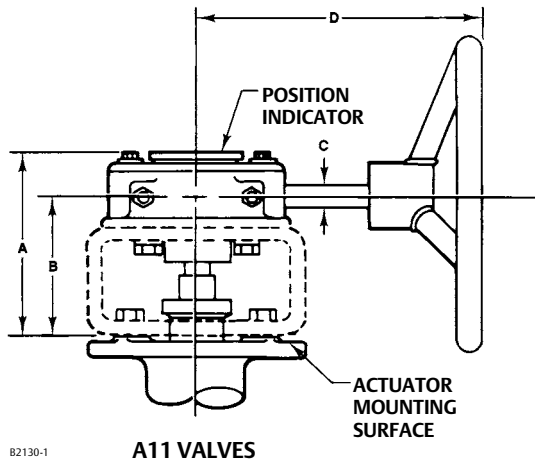

B2130-1

A11 VALVES

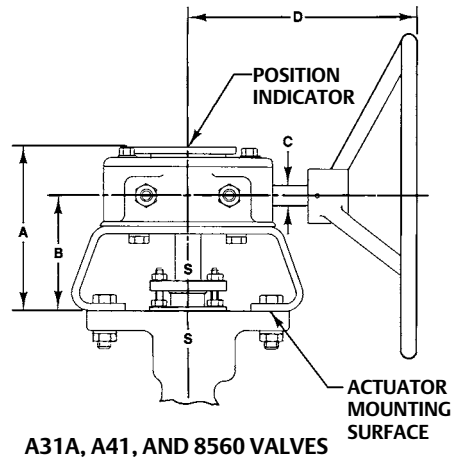

A31A, A41, AND 8560 VALVES

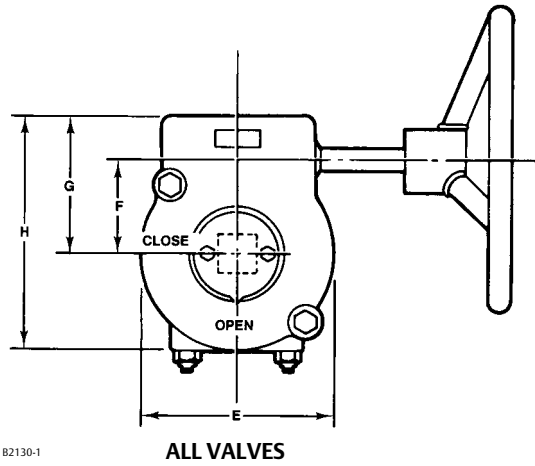

B2130-1

ALL VALVES

Table 4. Dimensions for A11 and A31A Compatible Actuators

ACTUATOR SIZE	DIMENSIONS												Handwheel Diameter
	A			B			C	D	E	F	G	H	
	A11	A31A CL150	A31A CL300	A11	A31A CL150	A31A CL300							
mm													
1KE	146 ⁽¹⁾	---	---	105 ⁽¹⁾	---	---	15.7	168	127	64	92	156	203
2KE	171	155	---	130	114	---	19.1	206	165	79	117	191	305
5KE	189	173	---	140	124	---	19.1	206	165	79	114	197	305
7KE	203	206 ⁽²⁾	254	146	130 ⁽³⁾	197	25.4	314	203	106	140	241	457
9KE	298	298	298	219	219	219	25.4	375	235	119	156	273	610
10KE-6	298	298	298	219	219	219	19.1	394	235	127	156	273	457
Inches													
1KE	5.75 ⁽¹⁾	---	---	4.12 ⁽¹⁾	---	---	0.62	6.62	5.00	2.50	3.62	6.12	8
2KE	6.75	6.12	---	5.12	4.50	---	0.75	8.12	6.50	3.12	4.62	7.50	12
5KE	7.44	6.81	---	5.50	4.88	---	0.75	8.12	6.50	3.12	4.50	7.75	12
7KE	8.00	8.12 ⁽²⁾	10.00	5.75	5.12 ⁽³⁾	7.75	1.00	12.38	8.00	4.12	5.50	9.50	18
9KE	11.75	11.75	11.75	8.62	8.62	8.62	1.00	14.75	9.25	4.69	6.12	10.75	24
10KE-6	11.75	11.75	11.75	8.62	8.62	8.62	0.75	15.50	9.25	5.00	6.12	10.75	18

1. The 1KE uses the 2KE A and B dimensions when it is mounted on an NPS 4 valve.
2. If the 7KE is used on an NPS 14 valve the A dimension is 206 mm (8.12 inches), on an NPS 16 valve it is 187 mm (7.38 inches), on an NPS 18 or 20 valve it is 254 mm (10.00 inches).
3. If the 7KE is used on an NPS 14 or 16 valve, the B dimension is 130 mm (5.12 inches), on an NPS 18 or 20 valve it is 197 mm (7.75 inches).

Table 5. Dimensions for A41 and 8560 Compatible Actuators

ACTUATOR SIZE	DIMENSIONS									Handwheel Diameter
	A	B	C	D	E	F	G	H		
	mm									
0KE/D1 0KE/D2 0KE/D3	127	97	16	178	105	44	67	119	203	
2KE/D4	137	102	19	203	165	79	117	191	305	
6KE/D5 6KE/D6	159 210	111 162	25	376	168	83	119	200	762 914	
9KE/D7	267	187	25	427	235	119	156	273	914	
Inches										
0KE/D1 0KE/D2 0KE/D3	5.0	3.814	0.625	7	4.125	1.725	2.625	4.6875	8	
2KE/D4	5.38	4.005	0.75	8	6.50	3.125	4.625	7.50	12	
6KE/D5 6KE/D6	6.25 8.25	4.375 6.375	1.0	14.81	6.625	3.25	4.688	7.875	30 36	
9KE/D7	10.5	7.375	1.0	16.81	9.25	4.6875	6.125	10.75	36	

Neither Emerson, Emerson Process Management, nor any of their affiliated entities assumes responsibility for the selection, use or maintenance of any product. Responsibility for proper selection, use, and maintenance of any product remains solely with the purchaser and end user.

Fisher is a mark owned by one of the companies in the Emerson Process Management business unit of Emerson Electric Co. Emerson Process Management, Emerson, and the Emerson logo are trademarks and service marks of Emerson Electric Co. All other marks are the property of their respective owners.

The contents of this publication are presented for informational purposes only, and while every effort has been made to ensure their accuracy, they are not to be construed as warranties or guarantees, express or implied, regarding the products or services described herein or their use or applicability. All sales are governed by our terms and conditions, which are available upon request. We reserve the right to modify or improve the designs or specifications of such products at any time without notice.

Emerson Process Management
Marshalltown, Iowa 50158 USA
Sorocaba, 18087 Brazil
Cernay, France 68700
Dubai, United Arab Emirates
Singapore 128461 Singapore

www.Fisher.com