

# Fisher™ 8580 Rotary Valve

## Contents

Introduction .....	1
Scope of Manual .....	1
Description .....	1
Educational Services .....	2
Specifications .....	2
Installation .....	4
Maintenance .....	7
Packing Maintenance .....	8
Replacing the Seal Ring Assembly .....	11
Replacing the Disk, Shafts, or Bearings .....	12
Actuator Mounting .....	16
Parts Ordering .....	19
Parts Kits .....	19
Parts List .....	20

Figure 1. Fisher 8580 Valve with 2052 Actuator and DVC6200 Digital Valve Controller



W9498-2

LUGGED STYLE

## Introduction

### Scope of Manual

This instruction manual includes installation, maintenance, and parts information for the Fisher 8580 valve, DN50 through DN300 or NPS 2 through NPS 12 (figure 1). Refer to separate instruction manuals for information covering the power on-off actuator and accessories.

Do not install, operate, or maintain an 8580 valve without being fully trained and qualified in valve, actuator, and accessory installation, operation, and maintenance. To avoid personal injury or property damage, it is important to carefully read, understand, and follow all the contents of this manual, including all safety cautions and warnings. If you have any questions about these instructions, contact your [Emerson sales office](#) or Local Business Partner before proceeding.

### Description

The 8580 rotary valve offers excellent throttling and quarter-turn performance. An approximately linear flow characteristic provides precise throttling control. The 8580 valve offers high cycle life and rugged reliability.

Retainer clips provide for versatility to mount and align the same wafer style valve body in different piping configurations (ASME and EN ratings). The valve body is compatible with PN 10 through PN 40, CL150, and CL300 ratings. Face-to-face dimensions meet EN 558, API 609, and MSS-SP68 standards.

The 8580 rotary valve features an eccentrically-mounted, double-offset disk with either soft or metal seal, providing capability for enhanced shutoff. The interchangeable sealing technology allows for the same valve body to accept both soft and metal seals.

## Educational Services

For information on available courses for Fisher 8580 valves, as well as a variety of other products, contact:

Emerson Automation Solutions  
 Educational Services - Registration  
 Phone: 1-641-754-3771 or 1-800-338-8158  
 E-mail: education@emerson.com  
 emerson.com/fishervalvetraining

Table 1. Fisher 8580 Valve Specifications

Specifications		EN	ASME
Valve Body Size		DN 50, 80, 100, 150, 200, 250, and 300	NPS 2, 3, 4, 6, 8, 10, and 12
Pressure Rating		PN 10 to 40 per EN 12516-1	CL150 / 300 per ASME B16.34, CL150 - 600 for NPS 2
Valve Body Materials		EN 1.0619 steel	WCC steel
		EN 1.4409 stainless steel	CF3M (316L) stainless steel
		CW2M <sup>(1)</sup>	CW2M <sup>(1)</sup>
		M35-2 <sup>(4)</sup>	M35-2
Disk Materials	PTFE or RPTFE Seal <sup>(3)</sup>	EN 1.4409 stainless steel	CF3M stainless steel
		CW2M	CW2M
		M35-2	M35-2
	Metal or UHMWPE <sup>(2)</sup> Seal	Chrome-plated EN 1.4409 Stainless Steel	Chrome-plated CF3M Stainless Steel
End Connections		Mates with raised-face flanges per EN 1092-1	Mates with raised-face flanges per ASME B16.5
Valve Body Style		Wafer (limited sizes) and lugged with tapped or through holes	
Face-to-Face Dimensions		Meets MSS SP68, API 609, and EN 558 standards	
Shutoff		PTFE, RPTFE, or UHMWPE seal ring - Class VI per ANSI/FCI 70-2 and IEC 60534-4	
		S31600 (316 SST) seal ring - Class IV per ANSI/FCI 70-2 and IEC 60534-4	
Flow Direction		Standard (forward flow) is with the seal retainer facing upstream; reverse flow is permissible for soft seals only	
Flow Characteristic		Approximately linear	
Disk Rotation		Counterclockwise to open (when viewed from actuator side of valve body) through 90 degrees of disk rotation	
<p>1. This material is not listed in EN 12516-1 or ASME B16.34. See table 4 for pressure/temperature ratings.            2. UHMWPE stands for ultra high molecular weight polyethylene.            3. RPTFE is a reinforced PTFE seal.            4. This material is not listed in EN 12516-1. See table 4 for pressure/temperature ratings.</p>			

Table 2. Valve Size, Shaft Diameter, and Approximate Weight

VALVE SIZE		PRESSURE RATING		SHAFT DIAMETER		APPROXIMATE WEIGHT			
						Wafer-Style		Lugged	
DN	NPS	EN	ASME	mm	Inches	kg	Pounds	kg	Pounds
50	2	PN10-40	CL150/600	12.7	1/2	4.7	10	6.7	15
80	3	PN10-40	CL150/300	15.9	5/8	---	---	11.2	25
100	4	PN10-40	CL150/300	19.1	3/4	---	---	17.6	39
150	6	PN10-40	CL150/300	25.4	1	15.7	35	26.5	58
200	8	PN10-16	CL150	31.8	1-1/4	---	---	40.9	90
		PN25-40	CL300	31.8	1-1/4	34.6	76	46.7	103
250	10	PN10-16	CL150	31.8	1-1/4	---	---	50.7	112
		PN25-40	CL300	31.8	1-1/4	52.0	115	79.4	175
300	12	PN10-16	CL150	38.1	1-1/2	---	---	98.6	217
		PN25-40	CL300	38.1	1-1/2	---	---	104.9	231

Table 3. Material Temperature Capabilities

MATERIAL					TEMPERATURE LIMITS <sup>(1)</sup>	
EN Materials						
Valve Body	Shaft	Bearing Lining and Jacket	Seal	Packing	°C	°F
1.0619 Steel	S17400 or S20910	PEEK / PTFE	PTFE or RPTFE	PTFE or Graphite	-10 to 232	14 to 450
			UHMWPE	PTFE or Graphite	-10 to 93	14 to 200
			Metal	PTFE or Graphite	-10 to 232	14 to 450
		R30006 (Alloy 6) or S31600 Nitride	Metal	Graphite	-10 to 400	14 to 752
1.4409 Stainless Steel	S20910	PEEK / PTFE	PTFE or RPTFE	PTFE or Graphite	-10 to 232	14 to 450
			UHMWPE	PTFE or Graphite	-10 to 93	14 to 200
			Metal	PTFE or Graphite	-10 to 232	14 to 450
		R30006 (Alloy 6) or S31600 Nitride	Metal	Graphite	-10 to 500 <sup>(2)</sup>	14 to 932 <sup>(2)</sup>
CW2M	N10276	PEEK / PTFE	PTFE or RPTFE	PTFE	-10 to 232	14 to 450
M35-2	N05500	PEEK / PTFE	PTFE or RPTFE	PTFE	-10 to 232	14 to 450
ASME Materials						
Valve Body	Shaft	Bearing Lining and Jacket	Seal	Packing	°C	°F
WCC steel	S17400 or S20910	PEEK / PTFE	PTFE or RPTFE	PTFE or Graphite	-29 to 232	-20 to 450
			UHMWPE	PTFE or Graphite	-18 to 93	0 to 200
			Metal	PTFE or Graphite	-29 to 232	-20 to 450
		R30006 (Alloy 6) or S31600 Nitride	Metal	Graphite	-29 to 427	-20 to 800
CF3M Stainless Steel	S20910	PEEK / PTFE	PTFE or RPTFE	PTFE or Graphite	-46 to 232	-50 to 450
			UHMWPE	PTFE or Graphite	-18 to 93	0 to 200
			Metal	PTFE or Graphite	-46 to 232	-50 to 450
		R30006 (Alloy 6) or S31600 Nitride	Metal	Graphite	-46 to 454 <sup>(2)</sup>	-50 to 850 <sup>(2)</sup>
CW2M	N10276	PEEK / PTFE	PTFE or RPTFE	PTFE	-46 to 232	-50 to 450
M35-2	N05500	PEEK / PTFE	PTFE or RPTFE	PTFE	-46 to 232	-50 to 450

1. Minimum allowable temperature for PN series flanges is -10°C (14°F). See requirements of EN 13445-2 Annex B for applications below -10°C (14°F) with PN series flanges.  
 2. For applications exceeding 427°C (800°F), consult your [Emerson sales office](#) or Local Business Partner for appropriate disk edge coating material selection.

Table 4. Maximum Allowable Inlet Pressure for CW2M and M35-2 Valves

TEMPERATURE	CW2M <sup>(1)</sup>						M35-2 <sup>(3)</sup>			
	150 <sup>(2)</sup>	300 <sup>(2)</sup>	PN 10 <sup>(2)</sup>	PN 16 <sup>(2)</sup>	PN 25 <sup>(2)</sup>	PN 40 <sup>(2)</sup>	PN 10 <sup>(2)</sup>	PN 16 <sup>(2)</sup>	PN 25 <sup>(2)</sup>	PN 40 <sup>(2)</sup>
°C	Bar						Bar			
-46 to 38	20.0	51.7	10.0	16.0	25.0	40.0	9.3	15.2	23.8	37.9
50	19.5	51.7	9.9	15.9	24.8	39.6	9.3	15.2	23.8	37.9
100	17.7	51.5	9.4	15.1	23.6	37.8	9.3	15.1	23.7	37.8
150	15.8	50.3	9.4	15.1	23.6	37.8	9.3	14.8	23.4	37.2
200	13.8	48.3	9.1	14.6	22.9	36.6	9.0	14.5	22.5	36.3
232	12.7	47.0	9.1	14.6	22.9	36.6	9.0	14.5	22.4	36.2
°F	Psig						Psig			
-50 to 100	290	750	145	232	362	580	135	220	345	550
200	260	750	144	230	359	575	135	220	345	540
300	230	730	137	219	342	548	135	215	340	525
400	200	700	133	212	331	530	130	210	325	525
450	185	680	133	212	331	530	130	210	325	525

1. This material is not listed in EN 12516-1 or ASME B16.34. Also see the Installation section.  
 2. The designations PN or 150 and 300 are used only to indicate relative pressure-retaining capabilities and are not EN or ASME pressure-temperature rating class designations.  
 3. This material is not listed in EN 12516-1. Also see the Installation section.

## Installation

Key numbers in this procedure are shown in figure 10 unless otherwise indicated.

### **⚠ WARNING**

Always wear protective gloves, clothing and eyewear when performing any installation operations to avoid personal injury.

To avoid personal injury or property damage resulting from the bursting of pressure retaining parts, be certain the service conditions do not exceed either the valve body rating or the flange joint rating, or other limits given in table 1 or on the nameplate. Use pressure-relieving or pressure-limiting devices to prevent the service conditions from exceeding these limits.

If installing into an existing application, also refer to the **WARNING** at the beginning of the Maintenance section on page 7 in this manual.

### **CAUTION**

The valve configuration and construction materials were selected to meet particular pressure, temperature, pressure drop, and controlled fluid conditions specified in the customer's order. Because some valve body/trim material combinations are limited in their pressure drop and temperature range capabilities, do not apply any other conditions to the valve without first contacting your [Emerson sales office](#) or Local Business Partner.

The maximum allowable inlet pressures for steel and stainless steel valve bodies are consistent with the pressure-temperature ratings shown in table 1, except where further limited by the trim and packing material temperature capabilities given in table 3. Valves are also available in CW2M and M35-2 valve body materials. The CW2M valve body material is not listed in EN 12516-1 or in ASME B16.34. The M35-2 valve body material is listed in ASME B16.34, but is not listed in EN 12516-1. Valve bodies constructed of these materials mate with EN and ASME flanges, but must not be installed in systems requiring conformance to EN or ASME standards if not included in EN or ASME pressure/temperature ratings. Maximum allowable inlet pressures for 8580 valve bodies made of CW2M or M35-2 construction materials are shown in table 4.

1. Install a three-valve bypass around the control valve assembly if continuous operation is necessary during inspection and maintenance of the valve body.
2. Inspect the valve body to be certain it is free of foreign material.
3. The valve is normally shipped as part of a control valve assembly, with an actuator mounted on the valve body.

If the valve body and actuator have been purchased separately or if the actuator has been removed for maintenance, mount the actuator, and adjust actuator travel before inserting the valve body into the line. This is necessary due to the measurements that must be made during the actuator adjustment process. Refer to the Actuator Mounting section on page 16 of this manual and to the separate actuator instruction manual for mounting and adjusting instructions before proceeding.

4. Inspect adjacent pipelines to be certain they are free of any foreign material, such as pipe scale or welding slag, that could damage the valve body seating surfaces.

### **CAUTION**

Damage to the disk (key 3) will occur if any pipe flanges or piping connected to the valve body interfere with the disk rotation path. However, the disk can be rotated without interference when the valve body is installed between adjacent pipe flanges or piping that has an inside diameter equal to or greater than either schedule 80 pipe or compatible EN pipe

---

sizes. If piping with a smaller inner diameter than specified above is connected to the valve, measure carefully to be certain the disk rotates without interference before putting the valve into operation.

---

5. Flow is in the standard direction when the seal retainer (key 2) is facing upstream. Standard flow direction is also indicated by the flow direction arrow cast into the valve body. Flow in the reverse direction is permissible within allowable pressure drop limits for the soft seal. The metal seal is forward flow only.

## CAUTION

8580 disk rotation is counterclockwise to open (when viewed from the actuator side of the valve body, see figure 7) through 90 degrees of disk rotation. Rotating the disk (key 3) past either the open or closed position could damage the seal and disk sealing surfaces and could cause the disk to jam in the seal retainer.

---

6. With the disk in the closed position, install line flange gaskets, and insert the valve between the pipeline flanges. Use either flat sheet gaskets or spiral-wound gaskets with compression-controlling centering rings. Spiral-wound gaskets without compression-controlling centering rings are not recommended for this purpose.
  7. Depending on valve size and pressure rating, the wafer style valve is centered in the pipeline using either retainer clips or the flange bolt holes. (For valves that have four flange bolt holes in the valve body (key 1), each hole engages one corresponding line flange stud.) Insert the valve between the flanges and use either the retainer clips or install two or more line flange studs into the line flanges to help hold the valve in position while centering the valve. Carefully center the valve on the flanges to ensure disk clearance.
- Select and install two pipeline gaskets.

---

### Note

Lubricate line flange studs before inserting them into flanges. If necessary, provide additional support for the control valve assembly because of its combined weight.

---

## ⚠ WARNING

For lugged valve bodies with threaded line bolt holes, personal injury and property damage could result from sudden release of process pressure if line bolts are not properly installed. To ensure proper line bolt thread engagement, line studs must be centered in the threaded section of the valve body so that each stud has equal thread engagement in the body. See figure 2.

---

8. After centering the valve body, first lubricate and then install the remaining line flange bolting to secure the valve in the pipeline. Tighten the nuts to the line flange studs in a crisscross pattern to ensure proper alignment of valve, gaskets, and flanges.

## ⚠ WARNING

An 8580 valve body is not necessarily grounded when installed in a pipeline. If the valve is used in a flammable or hazardous atmosphere or for oxygen service, an explosion could result due to a discharge of static electricity from the valve components. To avoid personal injury or property damage, always make sure the valve body is grounded to the pipeline before putting the control valve assembly into operation in a flammable or hazardous atmosphere.

---

Table 5. Stud Bolt Data

VALVE SIZE	WAFER STYLE AND LUGGED STYLE WITH THROUGH DRILLED HOLES											
	PN 10			PN 16			PN 25			PN 40		
DN	No. of Stud Bolts	Size Dia & Thread, mm	A Dimension, mm	No. of Stud Bolts	Size Dia & Thread, mm	A Dimension, mm	No. of Stud Bolts	Size Dia & Thread, mm	A Dimension, mm	No. of Stud Bolts	Size Dia & Thread, mm	A Dimension, mm
50	4	M16X2	125	4	M16X2	125	4	M16X2	130	4	M16X2	130
80	8	M16X2	140	8	M16X2	140	8	M16X2	150	8	M16X2	150
100	8	M16X2	150	8	M16X2	150	8	M20X2.5	160	8	M20X2.5	160
150	8	M20X2.5	160	8	M20X2.5	160	8	M24X3	180	8	M24X3	180
200	8	M20X2.5	170	12	M20X2.5	170	12	M24X3	190	12	M27X3	210
250	12	M20X2.5	180	12	M24X3	190	12	M27X3	210	12	M30X3.5	230
300	12	M20X2.5	190	12	M24X3	200	16	M27X3	230	16	M30X3.5	250

VALVE SIZE	LUGGED STYLE (THREADED HOLES)											
	PN 10			PN 16			PN 25			PN 40		
DN	No. of Stud Bolts	Size Dia & Thread, mm	B Dimension, mm	No. of Stud Bolts	Size Dia & Thread, mm	B Dimension, mm	No. of Stud Bolts	Size Dia & Thread, mm	B Dimension, mm	No. of Stud Bolts	Size Dia & Thread, mm	B Dimension, mm
50	---	---	---	---	---	---	---	---	---	---	---	---
80	16	M16X2	85	16	M16X2	85	16	M16X2	90	16	M16X2	90
100	16	M16X2	90	16	M16X2	90	16	M20X2.5	100	16	M20X2.5	100
150	16	M20X2.5	110	16	M20X2.5	110	---	---	---	---	---	---
200	16	M20X2.5	110	24	M20X2.5	110	24	M24X3	120	---	---	---
250	24	M20X2.5	120	24	M24X3	120	24	M27X3	130	---	---	---
300	24	M20X2.5	120	24	M24X3	130	24	M27X3	140	24	M30X3.5	150

VALVE SIZE	WAFER STYLE AND LUGGED STYLE WITH THROUGH DRILLED HOLES						LUGGED STYLE (THREADED HOLES)					
	CL150			CL300			CL150			CL300		
NPS	No. of Stud Bolts	Size Dia & Thread, Inch	A Dimension, Inch	No. of Stud Bolts	Size Dia & Thread, Inch	A Dimension, Inch	No. of Stud Bolts	Size Dia & Thread, Inch	B Dimension, Inch	No. of Stud Bolts	Size Dia & Thread, Inch	B Dimension, Inch
2	4	5/8-11	5	8	5/8-11	5.25	---	---	---	---	---	---
3	4	5/8-11	5.75	8	3/4-10	6.5	8	5/8-11	4.00	16	3/4-10	4.25
4	8	5/8-11	6	8	3/4-10	7	16	5/8-11	4.00	16	3/4-10	4.50
6	8	3/4-10	6.5	12	3/4-10	7.5	16	3/4-10	4.25	24	3/4-10	4.75
8	8	3/4-10	7	12	7/8-9	9	16	3/4-10	4.50	24	7/8-9	5.50
10	12	7/8-9	8	16	1-8	10	24	7/8-9	5.00	32	1-8	6.50
12	12	7/8-9	8.5	16	1-1/8-8	11	24	7/8-9	5.25	32	1-1/8-8	7.00

Figure 2. Stud Bolts for Installation (also see table 5)

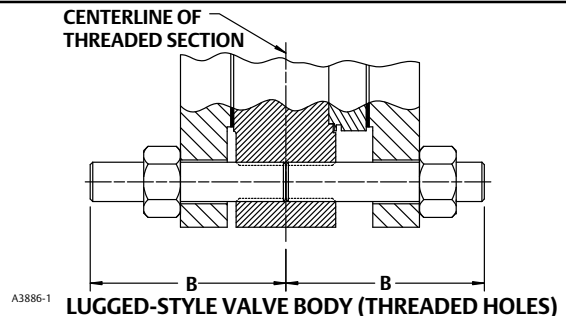
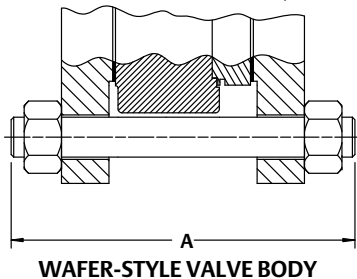
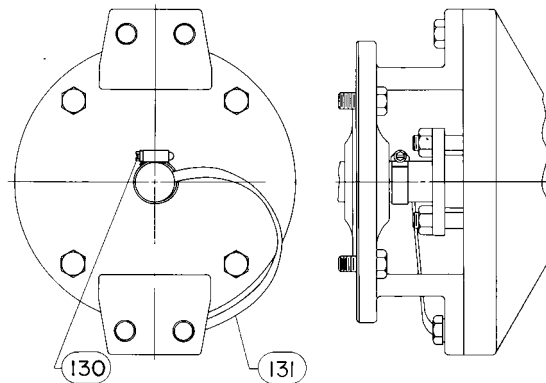

Figure 3. Optional Shaft-to-Valve Body Bonding Strap Assembly

**Note**

Standard packings for the 8580 valve are composed of all conductive packing rings (graphite ribbon packing) or partially conductive packing rings (such as a carbon-filled PTFE female adaptor with PTFE V-ring packing) to electrically bond the shaft to the valve body for hazardous area service. For oxygen service applications, provide alternate shaft-to-valve body bonding according to the following step.

9. For oxygen service applications, attach the bonding strap assembly (key 131, figure 3) to the shaft with the clamp (key 130, figure 3), and connect the other end of the bonding strap assembly to the valve body with the cap screw (key 35). Secure each cap screw with a hex nut (key 36).

**⚠ WARNING**

**Personal injury could result from packing leakage. Valve packing was tightened prior to shipment; however, the packing might require some re-adjustment to meet specific service conditions.**

Valves with ENVIRO-SEAL™ packing systems will not require this initial re-adjustment. See ([D101643X012](#)) for packing instructions. If you wish to convert your present packing arrangement to ENVIRO-SEAL packing, refer to the retrofit kits listed in the parts kit sub-section on page 19 of this manual.

## Maintenance

Valve body parts are subject to normal wear and must be inspected regularly and replaced as necessary. The frequency of inspection and replacement depends upon the severity of service conditions. Instructions are given in this section for: replacing trim components, changing disk rotation or valve action, and mounting and adjusting the actuator.

As used in these instructions, actuator refers to power actuators (such as pneumatic diaphragm, piston actuators, and rack and pinion actuators).

**⚠ WARNING**

**Avoid personal injury and property damage from sudden release of process pressure or bursting of parts. Before performing any maintenance operations:**

- Do not remove the actuator from the valve while the valve is still pressurized.
- Always wear protective gloves, clothing, and eyewear when performing any maintenance operations.
- Disconnect any operating lines providing air pressure, electric power, or a control signal to the actuator. Be sure the actuator cannot suddenly open or close the valve.
- Use bypass valves or completely shut off the process to isolate the valve from process pressure. Relieve process pressure on both sides of the valve. Drain the process media from both sides of the valve.
- Vent the power actuator loading pressure and relieve any spring precompression.
- Use lock-out procedures to be sure the above measures stay in effect while you work on the equipment.
- The valve packing box may contain process fluids that are pressurized, *even when the valve has been removed from the pipeline*. Process fluids may spray out when removing the packing hardware or packing rings, or when loosening the packing box pipe plug.
- Check with your process or safety engineer for any additional measures that must be taken to protect against process media.

## Packing Maintenance

Refer to figure 4 for available packing configurations. All maintenance operations in this section may be performed with the valve in the line. Packing may be PTFE V-ring or graphite.

An ENVIRO-SEAL packing system is also available with the 8580 valve. To install the ENVIRO-SEAL packing system in an existing valve, follow the instructions in the instruction manual included with the packing system ([D101643X012](#)). To remove packing parts in a valve with the ENVIRO-SEAL packing system, follow the procedures for valves with the ENVIRO-SEAL packing system in this section. Install the replacement packing following the instructions in the packing system instruction manual (D101643X012).

## Stopping Leakage

For valves with PTFE or graphite packing:

### CAUTION

**Tighten the packing flange only enough to prevent shaft leakage. Excessive tightening will only accelerate wear of the packing and could produce higher torques on the valve.**

Leakage around the packing followers can be stopped by tightening the packing flange nuts (key 28, figure 10).

If the packing is relatively new and tight on the shaft, and if tightening the packing flange nuts does not stop leakage, the shaft may be worn or nicked so that a seal cannot be made. If the leakage comes from the outside diameter of the packing, the leakage may be caused by nicks or scratches around the packing box wall. Inspect the shaft and packing box wall for nicks and scratches when performing the packing replacement procedures.

For valves with the ENVIRO-SEAL packing system:

Optimum performance of the ENVIRO-SEAL packing system is obtained when the Belleville springs are tightened to their “target load.” The target load is the point where the springs are compressed to 85% of their maximum deflection, or nearly flat. Maximum deflection is when the springs are 100% compressed, or completely flat.

Under normal conditions, the packing nuts should not require re-tightening. However, when servicing, if the springs do not remain at the target load of 85% compression, retighten the packing box nuts according to the following procedure:



Figure 4. Packing Arrangement Details

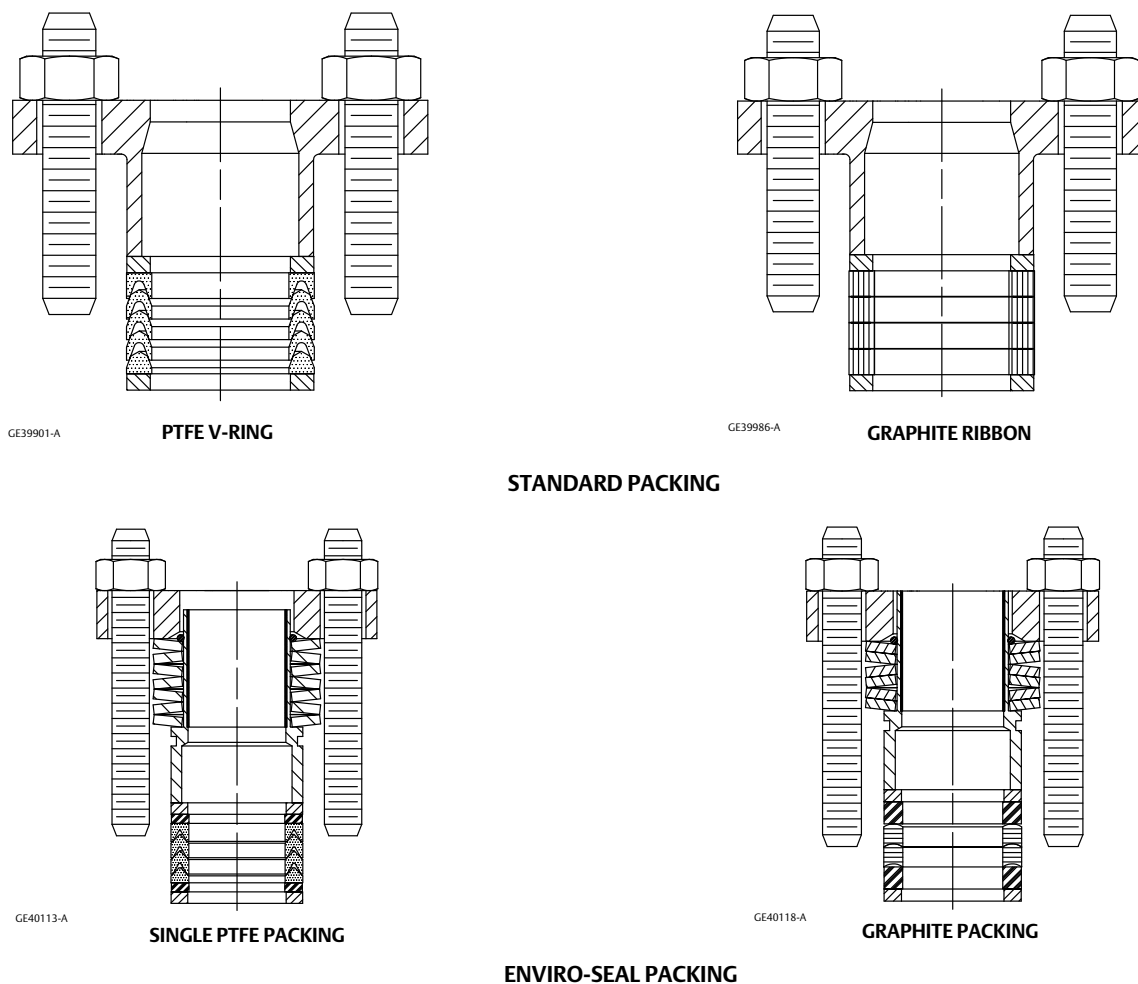

NOTES:

- 1 WITH CONDUCTIVE PACKING, THE FEMALE ADAPTOR IN PTFE V-RING PACKING IS CARBON-FILLED PTFE.
- 2 APPLY LUBRICANT.
- 3 THESE TWO SURFACES SHOULD REMAIN PARALLEL AS YOU ALTERNATELY AND EVENLY TIGHTEN THE PACKING NUTS (KEY 28).

1. Tighten the packing flange nuts alternately and evenly, keeping the packing flange parallel with the valve flange (see figure 4), until the Belleville springs are compressed 100% (or completely flat).

- For PTFE packing, loosen each packing flange nut one half turn (180° of rotation).
- For Graphite packing, loosen each packing flange nut one quarter turn (90° of rotation).

The target load of 85% compression has now been reached. If leakage continues, replace the packing components as described in the following procedures.

### Replacing the Packing

To replace the packing, the actuator must be removed. Also, the valve should be removed from the pipeline to allow proper readjustment of the disk position.

**⚠ WARNING**

The edges of a rotating disk have a shearing effect that may result in personal injury. To help prevent such injury, stay clear of the disk edges when rotating the disk (key 3).

**CAUTION**

Damage to the disk (key 3) may occur if the disk is not closed when the valve is being removed from the pipeline. If necessary, apply operating pressure to the actuator temporarily to retain the disk in the closed position while removing the valve from the pipeline.

For valves with PTFE or graphite packing:

Key numbers in this procedure are shown in figure 10 unless otherwise indicated.

1. Isolate the control valve from the line pressure, release pressure from both sides of the valve body, and drain the process media from both sides of the valve. If using a power actuator, also shutoff all pressure lines to the power actuator, release all pressure from the actuator. Use lock-out procedures to be sure the above measures stay in effect while you work on the equipment.

**CAUTION**

When removing the actuator in the following step, use a wheel puller to separate the actuator parts from the valve shaft. Do not drive the actuator parts off the valve shaft because this could damage valve trim components.

2. Remove the actuator per instructions in separate actuator instruction manuals, then remove the cap screws and nuts (keys 35 and 36). Remove the clamp (key 130, figure 3) if the strap (key 131, figure 3) is used.
3. Remove the packing flange nuts and the packing flange (key 26) if used and pull out the packing follower (key 25).
4. Remove the anti-blowout ring (key 40) from the drive shaft (key 10).
5. Remove the old packing rings (key 24) and, if used, the packing washers (key 31). Carefully avoid scratching the shaft or packing box wall to avoid damage that could cause leakage around the shaft. Clean all accessible metal parts and surfaces to remove particles that would prevent the packing from sealing.

**⚠ WARNING**

Do not lubricate parts when used in oxygen service, or where the lubrication is incompatible with the process media. Any use of lubricant can lead to the sudden explosion of media due to the oil/oxygen mixture, causing personal injury or property damage.

6. Use the appropriate procedures below for installing packing.

- Install the packing as shown in figure 4.
- With graphite ribbon packing, stack the packing rings and packing washers together, and slide the stack into the packing box as far as it will go while carefully avoiding trapping air between the rings.

- Install the anti-blowout ring (key 40) in the groove on the drive shaft (key 10).
  - Install the packing follower and, if used, the packing flange.
  - Install the packing flange nuts, and tighten them only far enough to stop leakage under normal operating conditions.
  - For oxygen service applications, attach the bonding strap assembly (key 131, figure 3) to the shaft with the clamp (key 130, figure 3), and connect the other end of the bonding strap assembly to the valve body with a cap screw (key 35). Secure each cap screw with a hex nut (key 36).
7. Mount the actuator and adjust the closed position of the valve, per the Actuator Mounting section on page 16 of this manual, before returning the valve to service.
  8. When placing the control valve into operation, check around the packing follower for leakage; retighten the packing flange nuts as required according to accepted bolting procedures.

For valves with ENVIRO-SEAL packing systems:

1. Isolate the control valve from the line pressure, release pressure from both sides of the valve body, and drain the process media from both sides of the valve. If using a power actuator, also shutoff all pressure lines to the power actuator, release all pressure from the actuator. Use lock-out procedures to be sure that the above measures stay in effect while you work on the equipment.

## CAUTION

**When removing the actuator, use a wheel puller to separate the actuator parts from the valve shaft. Do not drive the actuator parts off the valve shaft because this could damage valve trim components.**

2. Remove the actuator per instructions in separate actuator instruction manuals, then remove the cap screws and nuts (keys 35 and 36). Remove the clamp (key 130, figure 3) if the strap (key 131, figure 3) is used.
3. Loosen the two packing hex nuts evenly to remove spring tension, then remove the nuts.
4. Remove the packing flange and spring pack assembly. The spring pack assembly consists of the spring stack and packing follower. The spring stack is retained on the packing follower by an O-ring. Remove the anti-blowout ring (key 40) from the driveshaft (key 10). Remove the anti-extrusion washer, the packing set, and the packing ring.

## CAUTION

**The valve shaft surface condition is critical in making and maintaining a good seal. If the valve shaft surface is scratched, nicked, dented, or worn, replace the valve shaft before replacing the packing system.**

5. Inspect the existing valve shaft. If necessary, replace the valve shaft as described in the Replacing the Disk, Shafts, or Bearings section.
6. Install the new packing system components as described in the ENVIRO-SEAL Packing System for Rotary Valves Instruction Manual ([D101643X012](#)).
7. Install the anti-blowout ring (key 40) onto the drive shaft (key 10) before installing the packing follower.
8. Mount the actuator and adjust the closed position of the valve, per the Actuator Mounting section on page 16 of this manual, before returning the valve to service.

## Replacing the Seal Ring Assembly

Perform this procedure only if the control valve is not shutting off properly (that is, leaking downstream). This procedure does not require removing the actuator from the valve body.

Key numbers in this procedure are shown in figure 10 unless otherwise indicated.

1. Isolate the control valve from line pressure, and relieve pressure from the valve body. Shut off and disconnect all lines from the power actuator.

### **⚠ WARNING**

**The edges of a rotating disk have a shearing effect that may result in personal injury. To help prevent such injury, stay clear of the disk edges when rotating the disk (key 3).**

### **CAUTION**

**Damage to the disk (key 3) may occur if the disk is not closed when the valve is being removed from the pipeline. If necessary, apply operating pressure to the actuator temporarily to retain the disk in the closed position while removing the valve from the pipeline.**

2. Unscrew the flange bolts, and remove the valve from the pipeline.
3. Unscrew the machine screws (key 14), remove the retainer clip (key 13), and remove the seal retainer (key 2).
4. Remove the seal ring assembly (key 4).
5. The valve must be closed during seal ring installation to permit accurate centering of the seal. To install the new seal ring assembly:
  - For a soft seal, if the spring (key 5) was disassembled, hook the spring ends together. Work the spring into the recess in the seal ring (key 4). Place the seal ring assembly onto the disk. Set the retainer onto the seal, making sure proper alignment between the seal and retainer has been achieved.
  - For the metal seal ring assembly, place the seal ring assembly onto the disk. Set the retainer onto the seal, making sure proper alignment between the seal and retainer has been achieved.
6. Attach the seal retainer (key 2) and the retainer clips (key 13) to the valve body and secure with the machine screws (key 14).
7. Be certain the disk is closed before installing the valve according to the Installation section on page 4 of this manual.

## Replacing the Disk, Shafts, or Bearings

Key numbers in this procedure are shown in figure 10 unless otherwise indicated.

1. Isolate the control valve from the line pressure, release pressure from both sides of the valve body, and drain the process media from both sides of the valve. If using a power actuator, also shutoff all pressure lines to the power actuator, release all pressure from the actuator. Use lock-out procedures to be sure that the above measures stay in effect while you work on the equipment.

### **CAUTION**

**When removing the actuator in the following step, use a wheel puller to separate the actuator parts from the valve shaft. Do not drive the actuator parts off the valve shaft because this could damage valve trim components.**

2. Remove the actuator per instructions in separate actuator instruction manuals, then remove the cap screws and nuts (keys 35 and 36). Remove the clamp (key 130, figure 3) if the strap (key 131, figure 3) is used.
3. Remove the packing flange nuts and the packing flange (key 26) if used and pull out the packing follower (key 25).

Figure 5. Orientation of Bearing Tabs

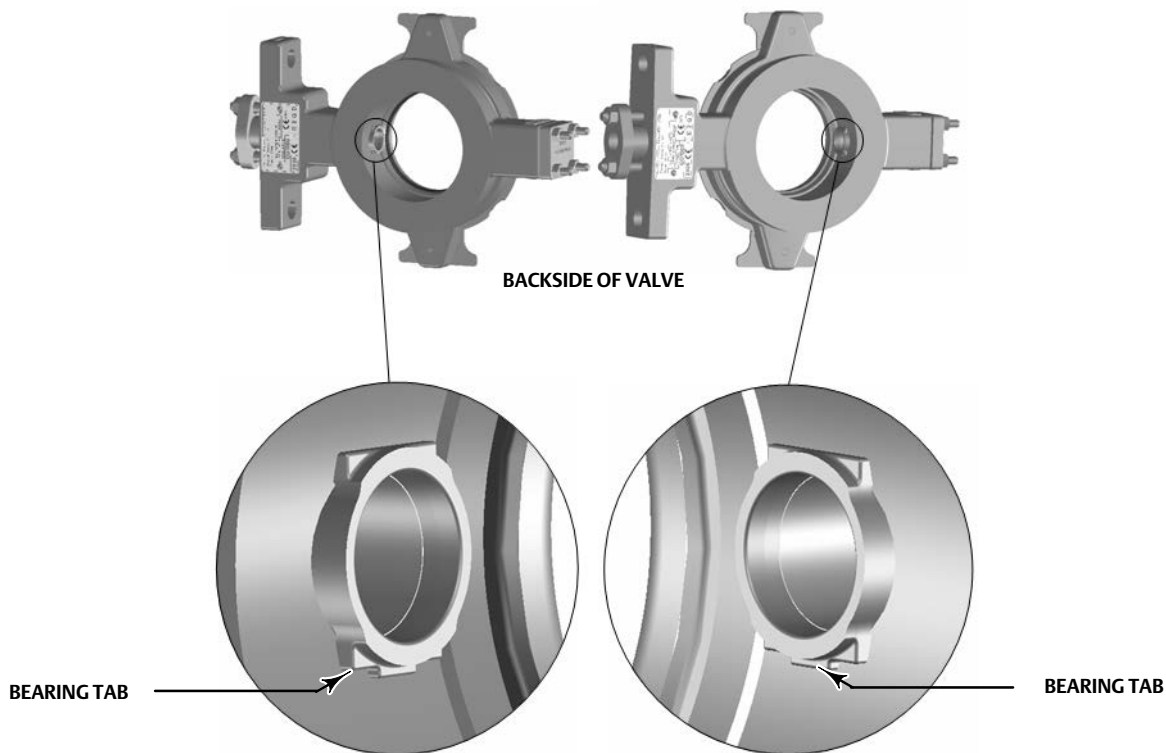

Table 6. Follower Shaft Internal Threads

VALVE SIZE		THREAD SIZE
DN	NPS	
50	2	M8 X 1.25
80	3	M10 X 1.50
100	4	M12 X 1.75
180	6	M16 X 2.00
200	8	M20 X 2.50 <sup>(1)</sup>
250	10	M20 X 2.50 <sup>(1)</sup>
300	12	M24 X 3.00 <sup>(1)</sup>

1. For valves with a two-piece, split-shaft design only. DN200 – 300 (NPS 8–12) valves changed to a one-piece, through-shaft design in 2015.

Table 7. Recommended Blind Flange Bolt Torque

VALVE SIZE		TORQUE	
DN	NPS	N•m	lbf•ft
50 to 150	2 to 6	9.5	7.0
200, 250	8, 10	23	17
300	12	45	33

## Disassembly

1. Remove the seal ring assembly according to steps 3 and 4 of the Replacing Seal Ring section on page 11 of this manual.
2. Remove hex nuts, blind flange, gasket, spacer (if present), follower spring seats, and follower spring (keys 19, 17, 16, 15, 9, and 12).
3. Clean the gasket surfaces on the blind flange (key 17) and on the end of the valve body (key 1).
4. Rotate the disk (key 3) to the fully open position.
5. Refer to figure 6 and determine the location of the smaller end of the taper pins (key 8). Drive out the taper pins and expansion pins (key 7) towards the larger end.

### **⚠ WARNING**

**Once the shafts have been removed in the following step, the disk may fall from the valve body. To avoid personal injury and disk damage, support the disk to prevent it from falling as the shafts are being removed.**

6. For valves with a two-piece, split shaft, pull the follower shaft (key 11) out through the outboard end of the valve body. If the follower shaft cannot be pulled free, the end of the follower shaft is internally threaded (see table 6) for screwing in a bolt or stud to aid in pulling the follower shaft.
7. Pull the drive shaft (key 10) out through the actuator end of the valve body and remove the anti-blowout ring (key 40) from the drive shaft.
8. Remove the disk (key 3) from the valve body.
9. Remove the packing (key 24, figure 4) and the packing box ring (key 23, figure 4).
10. If either of the bearings (key 6) require replacement, remove them.
11. Clean the packing box and [metal packing box parts].

## Assembly

### **⚠ WARNING**

**Do not lubricate bearings that will be used for oxygen service, or where the lubrication is incompatible with the process media. Any use of lubricant can lead to the sudden explosion of media due to the oil/oxygen mixture, causing personal injury or property damage.**

### **CAUTION**

**To avoid possible product damage, ensure the bearing tabs are oriented correctly when installing in the following procedure. See figure 5 for proper orientation of the bearings.**

1. If new bearings (key 6) are required, install and orient them in the valve body, as shown in figure 5. Ensure the bearings are fully seated, contacting the inside diameter of the valve body.
2. Insert the disk into the valve body as shown in figure 6, ensuring the “T” stamped on the disk hub is oriented toward the actuator end of the valve body.
3. Install the drive shaft (key 10) through the valve body into the disk. The disk/shaft connection utilizes taper and expansion pins. The hole for the drive shaft connection is slightly off-center to prevent the drive shaft from being

installed in the wrong orientation. Orient the position indication mark on the end of the shaft with the face of the disk as shown in figure 7. For assemblies using a two-piece, split shaft, the hole for the follower shaft connection is on-center. Insert the expansion pins into the disk until they are seated, as shown in figure 6. Once in place, insert the taper pins. The taper pins must be driven into the disk/shaft/expansion pin assemblies until “solid contact” is felt. “Solid contact” can be identified by the sound of the hammer blow and the bounce felt in the hammer. NPS 8-12 valves changed to a one-piece, through-shaft design in October 2015 and utilize only one pin connection. NPS 8-12 valves shipped prior to October 2015 used a two-piece, split-shaft design with two pin connections - same as the NPS 2-6 valves.

Figure 6. Taper / Expansion Pin Installation

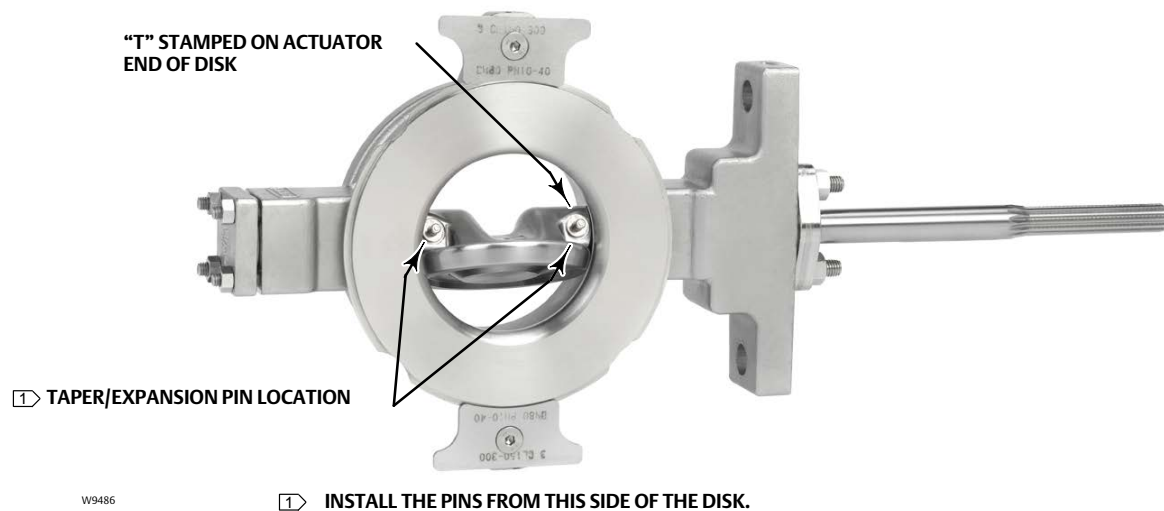

4. Reinstall the follower spring/spring seat assembly (keys 9, 12, and 9, figure 8) inside the follower shaft or follower side of the drive shaft for valves with a one-piece, through-shaft design.
5. Install the spacer (key 15) if used, and the gasket, blind flange, and hex nuts (keys 16, 17, and 19). Ensure the blind flange is oriented so the serrations face the gasket and valve body. Tighten the hex nuts (key 19) per table 7.
6. The valve must be closed during seal ring installation to permit accurate centering of the seal. To install the new seal ring assembly or flow ring:

Table 8. Recommended Actuator-Mounting Bolt Torque

VALVE SIZE		TORQUE	
DN	NPS	N•m	lbf•ft.
50, 80, 100, and 150	2, 3, 4, and 6	120	88
200, 250, and 300	8, 10, and 12	250	185

- For a soft seal, if the spring (key 5) was disassembled, hook the spring ends together. Work the spring into the recess in the seal ring (key 4). Place the seal ring assembly onto the disk. Set the retainer onto the seal, making sure proper alignment between the seal and retainer has been achieved.
  - For the metal seal ring assembly, place the seal ring assembly onto the disk. Set the retainer onto the seal.
  - For the flow ring construction, place the gasket (key 41) onto the valve body. Set the retainer onto the gasket.
7. Attach the seal retainer (key 2) and the retainer clips (key 13) to the valve body and secure with the machine screws (key 14).
  8. Insert a packing box ring (key 23) into the packing box.

Figure 7. Sectional of Typical Valve Body

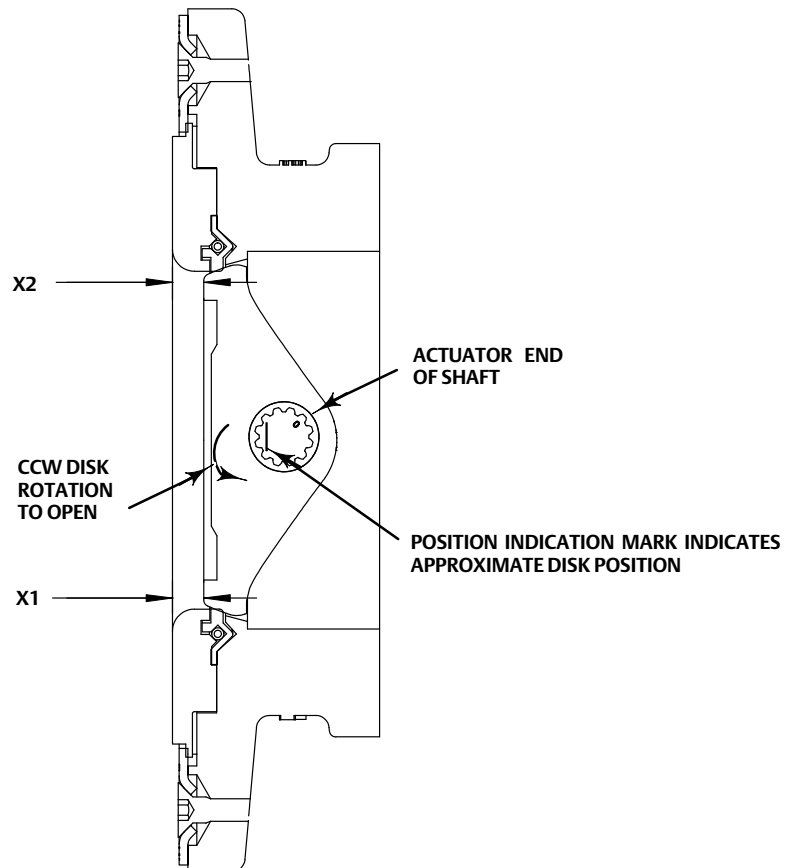

9. For standard packing, install the packing according to the appropriate instructions presented in step 5 of the Replacing Packing section on page 10 of this manual.

For ENVIRO-SEAL packing, install the new packing system components as described in [D101643X012](#).

10. Install the anti-blowout ring (key 40) in the groove in the drive shaft.

11. Rotate the disk to the approximate closed position.

12. Mount and adjust the actuator per the following Actuator Mounting section on page 16 of this manual.

## Actuator Mounting

With the valve body out of the line, mount the actuator on the valve body in accordance with the instructions in the actuator instruction manual. Mount the actuator yoke to the valve body, and tighten the actuator-mounting cap screws and nuts (keys 35 and 36) to the appropriate torque from table 8.

Key numbers in this procedure are shown in figure 10 unless otherwise indicated.

1. Determine the actuator mounting style and position from figure 9.



Figure 8. Follower Spring/Spring Seat Assembly

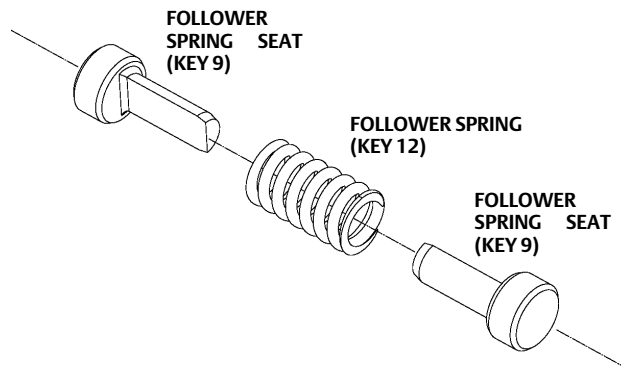

**CAUTION**

8580 valve disk rotation is counterclockwise to open (when viewed from the actuator side of the valve body, see figure 7). Rotating the disk (key 3) past the fully closed position will damage the seal ring (key 4). To prevent this damage, use the following procedures:

- For actuators with adjustable travel stops, such as a Fisher 2052, 1051/1052 size 33, 1066 or 1066SR actuator, make certain the actuator travel stop prevents the disk from rotating past the fully closed position.
- For actuators with an adjustable turnbuckle, such as the Fisher 1051/1052 size 40, 60, and 70, or 1061 actuator, the turnbuckle must be adjusted so that the valve is closed when the diaphragm plate or piston is against the actuator travel stop.

2. Adjust the actuator to bring the disk to the fully closed position at the end of the actuator stroke. To determine the fully closed disk position, measure the distances between the disk face and the seal retainer face at the top and bottom of the valve (X1 and X2) as shown in figure 7. Adjust the travel stops or turnbuckle to rotate the disk slightly until the two measurements are within 0.8 mm (0.032 inch) of each other. Refer to the appropriate actuator instruction manual for assistance.

Figure 9. Lever/Shaft/Disk Orientation with Valve Closed

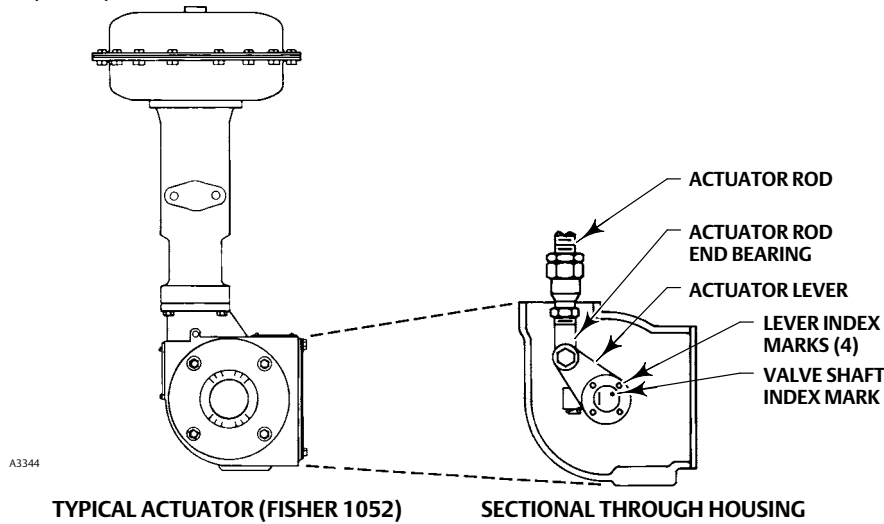

ACTUATOR MOUNTING		VALVE CLOSED ◀ 4	MOUNTING POSITION 1 ◀ 5	MOUNTING POSITION 2 ◀ 5	MOUNTING POSITION 3 ◀ 5	MOUNTING POSITION 4 ◀ 5
RIGHT-HAND 1	STYLE					
RIGHT-HAND 1	STYLE A (PDTO)	FORWARD FLOW				
	STYLE B (PDTC) 3	FORWARD FLOW				
LEFT-HAND 2	STYLE C (PDTC) 3	FORWARD FLOW				
	STYLE D (PDTO)	FORWARD FLOW				

NOTES:

- 1 WHEN ONE IS FACING THE INLET, THE ACTUATOR IS TO THE RIGHT OF THE VALVE BODY.
  - 2 WHEN ONE IS FACING THE INLET, THE ACTUATOR IS TO THE LEFT OF THE VALVE BODY.
  - 3 FOR 60-DEGREE OPERATION WITH PUSH-DOWN-TO-CLOSE ACTION (EXTENDING ACTUATOR ROD CLOSES VALVE), ROTATE ACTUATOR LEVER COUNTERCLOCKWISE SO THAT LEVER INDEX MARK IS OFFSET 1 SPLINE TOOTH FROM VALVE SHAFT INDEX MARK FOR NPS 2 THROUGH 4 VALVES AND 2 SPLINE TEETH FROM VALVE SHAFT INDEX MARK FOR NPS 6 THROUGH 12 VALVES.
  - 4 CURVED ARROWS IN "VALVE CLOSED" COLUMN INDICATE ROTATION REQUIRED TO OPEN VALVE (COUNTERCLOCKWISE WHEN VIEWED FROM ACTUATOR SIDE OF VALVE).
  - 5 ARROWS IN "MOUNTING POSITION" COLUMNS INDICATE DIRECTION OF ACTUATOR ROD TRAVEL REQUIRED TO OPEN VALVE.
6. PDTC—PUSH DOWN TO CLOSE; PDTO—PUSH DOWN TO OPEN.

## Parts Ordering

When corresponding with your [Emerson sales office](#) or Local Business Partner about this equipment, always mention the valve serial number.

### **⚠ WARNING**

**Use only genuine Fisher replacement parts. Components that are not supplied by Emerson Automation Solutions should not, under any circumstances, be used in any Fisher valve, because they may void your warranty, might adversely affect the performance of the valve, and could cause personal injury and property damage.**

## Parts Kits

### Retrofit Kits for ENVIRO-SEAL Packing

Retrofit kits are available for replacing the packing in an existing valve with an ENVIRO-SEAL packing system. These kits are available for single PTFE or graphite packing. All parts required for installation of the ENVIRO-SEAL packing system into an existing 8580 valve are included in the kits.

Worn shafts, packing box damage, or other components that do not meet Emerson Automation Solutions finish specifications, dimensional tolerances, and design specifications, may adversely alter the performance of the retrofit kit.

ENVIRO-SEAL Packing System Retrofit Kits

SHAFT DIAMETER		SINGLE PTFE PACKING	GRAPHITE PACKING
mm	Inches		
12.7	1/2	RPACKXRT482	RPACKXRT422
15.9	5/8	RPACKXRT492	RPACKXRT432
19.1	3/4	RPACKXRT502	RPACKXRT442
25.4	1	RPACKXRT512	RPACKXRT452
31.8	1-1/4	RPACKXRT522	RPACKXRT462
38.1	1-1/2	RPACKXRT532	RPACKXRT472

### Repair Kits for ENVIRO-SEAL Packing

Repair kits for ENVIRO-SEAL PTFE packing include one packing set and two anti-extrusion washers. Repair kits for ENVIRO-SEAL graphite packing include two packing rings and two anti-extrusion rings.

Worn shafts, packing box damage, or other components that do not meet Emerson Automation Solutions finish specifications, dimensional tolerances, and design specifications, may adversely alter the performance of the repair kit.

ENVIRO-SEAL Packing System Repair Kits

SHAFT DIAMETER		FOR PTFE PACKING	FOR GRAPHITE PACKING
mm	Inches		
12.7	1/2	RRTYX000012	13B8816X012
15.9	5/8	RRTYX000022	13B8816X032
19.1	3/4	RRTYX000032	13B8816X052
25.4	1	RRTYX000052	13B8816X092
31.8	1-1/4	RRTYX000062	13B8816X112
38.1	1-1/2	RRTYX000072	13B8816X142

## Parts List

---

### Note

Contact your [Emerson sales office](#) or Local Business Partner for Part Ordering information.

---

Key	Description	Key	Description
1	Valve Body If you need a new valve body, please order by valve size, serial number and desired material.	15	Spacer
2	Seal Retainer / Flow Ring	16*	Gasket
3*	Disk	17	Blind Flange
4*	Seal Ring	18	Stud
5*	Spring	19	Hex Nut
6*	Bearing (2 req'd)	20	Drive Screw
7*	Expansion Pin (NPS 2-6, 2 req'd) (NPS 8-12, 1 req'd <sup>(1)</sup> )	21	Nameplate
8*	Taper Pin (NPS 2-6, 2 req'd) (NPS 8-12, 1 req'd <sup>(1)</sup> )	22	Mfg Label
9	Follower Spring Seats	23*	Packing Box Ring
10*	Drive Shaft	24*	Packing Set
11*	Follower Shaft (when used)	24*	Packing Ring (4 req'd)
12	Follower Spring	24*	Packing Set, ENVIRO-SEAL
13	Retainer Clip	24*	Packing Set, ENVIRO-SEAL
14	Machine Screw, Flat Head, Hex Socket	25	Packing Follower
		26	Packing Flange
		27	Packing Stud
		28	Packing Nut
		29*	Anti-extrusion Ring, ENVIRO-SEAL, use w/ PTFE packing
		30	Spring Pack Assy
		31*	Packing Washer
		32	Tag
		33	Cable Tie
		34	Mounting Bracket
		35	Cap Screw
		36	Hex Nut
		37	Lubricant
		39	Machine Screw, Flat Head, Hex Socket
		40	Anti-blowout Ring
		41*	Gasket, Flow Ring
		130	Clamp
		131	Bonding Strap Assy

**Figure 10. Fisher 8580 Valve Assembly**

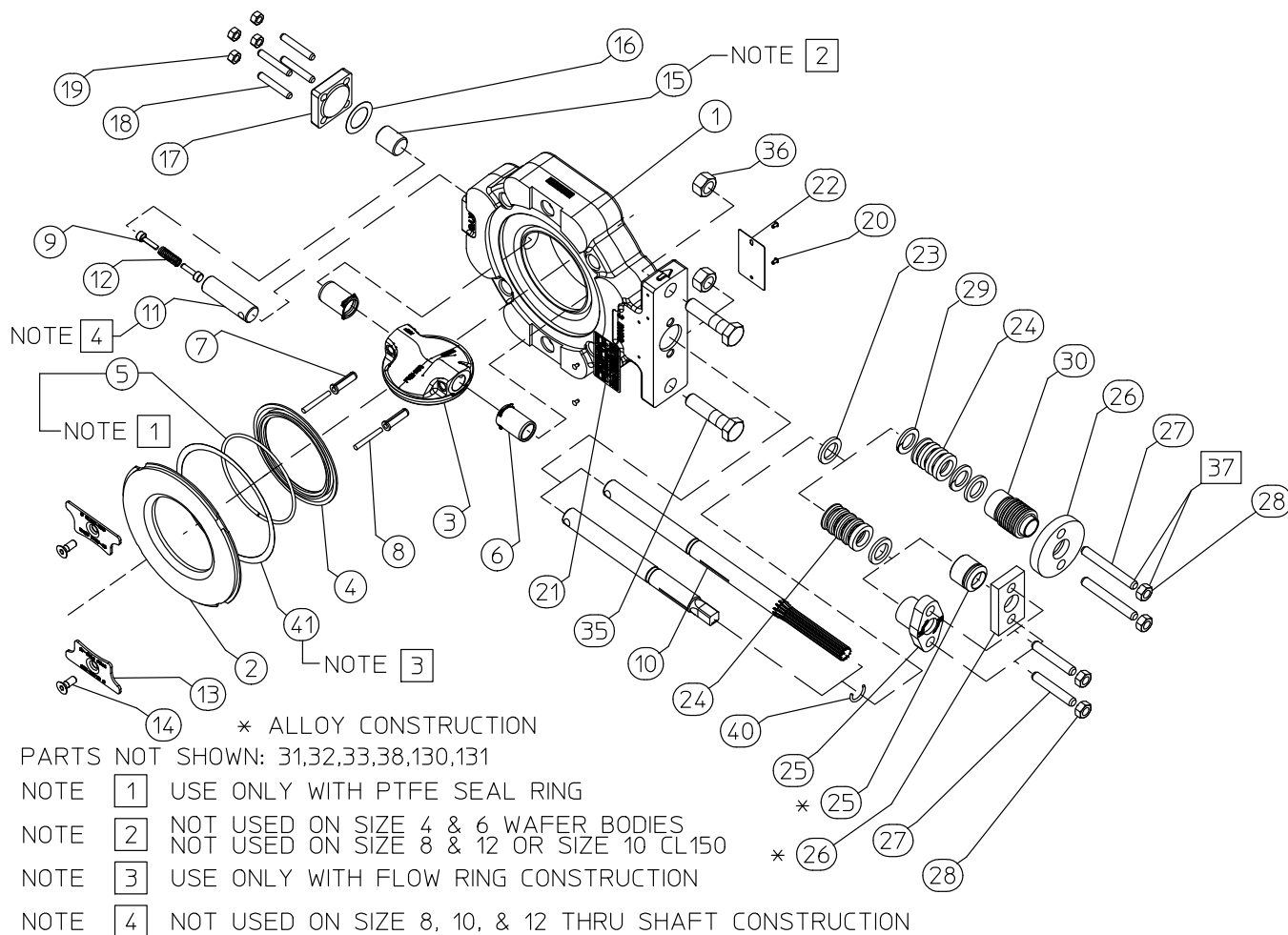

GE36048-F

Figure 11. Fisher 8580 Seal Assembly Detail

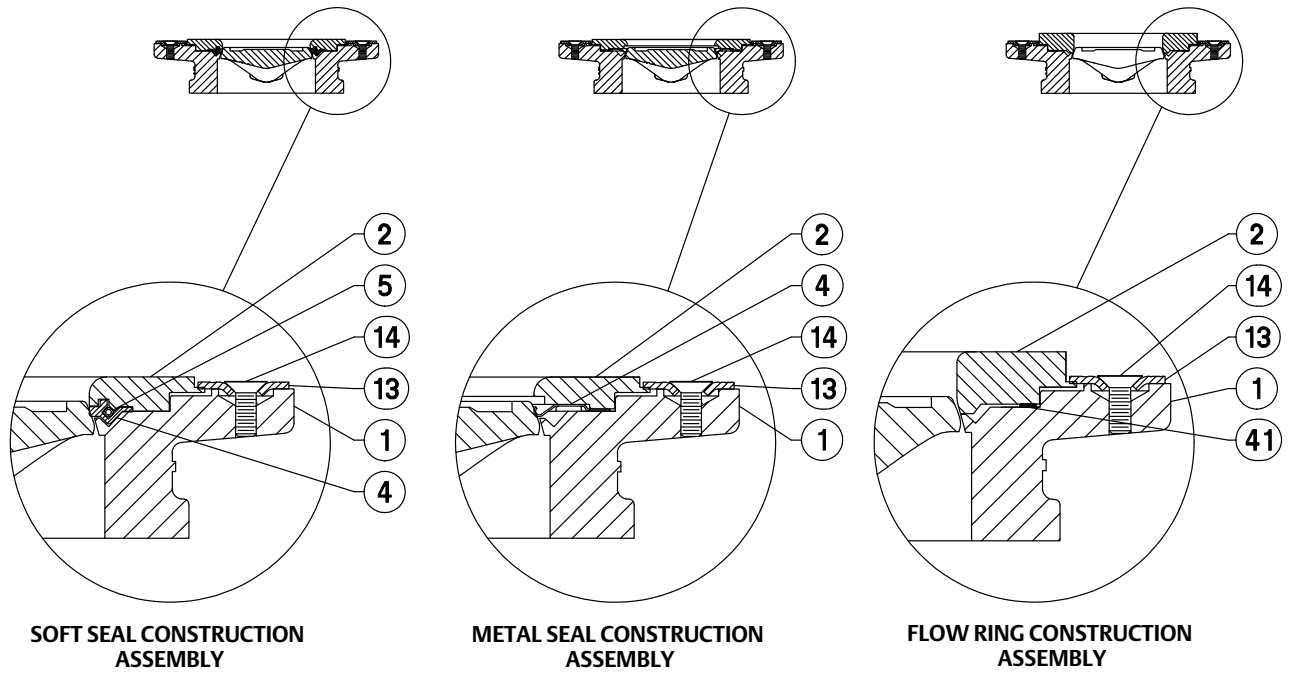

GE36048\_D\_2



Neither Emerson, Emerson Automation Solutions, nor any of their affiliated entities assumes responsibility for the selection, use or maintenance of any product. Responsibility for proper selection, use, and maintenance of any product remains solely with the purchaser and end user.

Fisher and ENVIRO-SEAL are marks owned by one of the companies in the Emerson Automation Solutions business unit of Emerson Electric Co. Emerson Automation Solutions, Emerson, and the Emerson logo are trademarks and service marks of Emerson Electric Co. All other marks are the property of their respective owners.

The contents of this publication are presented for informational purposes only, and while every effort has been made to ensure their accuracy, they are not to be construed as warranties or guarantees, express or implied, regarding the products or services described herein or their use or applicability. All sales are governed by our terms and conditions, which are available upon request. We reserve the right to modify or improve the designs or specifications of such products at any time without notice.

Emerson Automation Solutions  
Marshalltown, Iowa 50158 USA  
Sorocaba, 18087 Brazil  
Cernay 68700 France  
Dubai, United Arab Emirates  
Singapore 128461 Singapore

[www.Fisher.com](http://www.Fisher.com)

