

Fisher™ EZ Sliding-Stem Control Valve

Fisher EZ valves (figure 1) are used for throttling or on-off control of a wide variety of liquids and gases. The single-port, globe-style body design offers quick-change trim and a post-guided, unbalanced valve plug. The EZ valve is used in chemical or hydrocarbon processing applications or wherever control of non-lubricating, viscous, or other hard-to-handle fluids is required.

Metal-to-metal seating is standard for all general applications over a wide range of pressure drops and temperatures. Metal-to-PTFE seating is optional for stringent shutoff requirements.

The easy-e™ Valve Family

EZ valve bodies are part of the versatile easy-e family of industrial control valves. easy-e valve bodies share the following characteristics:

- Multiple trim material choices
- Trim temperature capability with standard metal seats to 427°C (800°F)
 - FGM gaskets
- Interchangeable, restricted-capacity trims and full-sized trims to match variable process flow demands
- Different valve plug styles that provide particular flow characteristics for highly-specialized applications. Standard plugs are available with the following flow characteristics:
 - quick-opening
 - linear
 - equal percentage
- Optional constructions allow material compatibility with NACE MR0175 / ISO 15156 and MR0103. Contact your Emerson Automation Solutions sales office for details.
- 316 stainless steel packing box parts are standard (including packing flange, studs, and nuts)



W2174-2

Fisher EZ Valve with 657 Actuator

Features

- **Trim Designed for Stability**-- Post guiding provides valve plug stability with less chance of a sticking valve plug due to non-lubricating or sticky process fluids or build-up of entrained solids. Post guiding stabilizes the valve plug at all points in its travel range to reduce vibration, mechanical noise, and trim wear.
- **Performance+ Seat Ring**-- Flow-straightening, vaned seat ring is available in full port and first reduction port sizes. It offers excellent open- and closed-loop performance and may be used as a direct replacement for the non-vaned seat ring. The Fisher valve division recommends that the Performance+ seat ring be used for non-viscous, flow-up, liquid applications.
- **Compliance with the Clean Air Act**-- ENVIRO-SEAL packing systems (figure 3) that provide an improved stem seal to help prevent the loss of process fluid are available. These packing systems feature PTFE, Graphite ULF, or duplex packing with live-loading for reduced packing maintenance.
- **Compliance with European Standards**-- Valves are available with dimensions specified by EN/DIN standards. See figure 6.
- **Sour Service Capability**-- Unless otherwise noted, references are to NACE MR0175-2002. Optional materials are available to meet NACE MR0103 and NACE MR0175 / ISO 15156. Material requirements under these standards vary by edition and year of issue; the specific standard must be specified.
- **Reliability**-- The process fluid flows through the trim, flushing away solid deposits above and below the guide bushing, thus reducing the possibility of a sticking valve plug.
- **Easy Maintenance**-- Quick-change trim, with a clamped-in seat ring, reduces the disassembly time. The valve body can stay in the pipeline during removal of trim parts for inspection or maintenance.
- **Application Flexibility**-- Low-flow requirements can be satisfied with standard restricted-capacity trim or with Micro-Form, Micro-Flute, or Micro-Flow valve plugs. If flow requirements change, the valve can be converted to full-sized trim.
- **Economy**-- Streamlined flow passages provide greater capacities than most globe valves of the same line size.

Table of Contents

Features	2	Valve Body/Trim Temperature Capabilities	11
Specifications	3	Bonnet Selection Guidelines	13
ENVIRO-SEAL™ Packing System Specifications	4	Maximum Allowable Pressure Drops	13
ENVIRO-SEAL and HIGH-SEAL Packing Systems	5	Gasket Selection Guidelines	14
ENVIRO-SEAL and HIGH-SEAL Features	6	Maximum Allowable Pressure Drops for Gasket Materials	15
Micro-Flute Valve Plugs for Minimum Leakage	9	Maximum Flow Coefficients	17
Class VI Shutoff Capabilities	8	Port Diameters, Valve Plug Travel, and Stem and Yoke Boss Diameters	17
Tables		Typical Combinations of Trim Parts	17
Class VI Shutoff	8	Bolting Materials and Temperature Limits	18
Class VI Trim Materials	8	Ordering Information	18
Material Cross Reference	9	Dimensions	18
Typical Combinations of Metal Trim Parts	9		
Construction Materials & Temperature Limits	10		

Specifications

Valve Sizes

NPS ■ 1/2, ■ 3/4, ■ 1, ■ 1-1/2, ■ 2, ■ 3, and ■ 4

End Connection Styles^(1, 2)

Cast Iron Valves

Flanged: NPS 1 through 4, ■ CL125 flat-face or ■ CL250 raised-face flanges per ASME B16.1

Steel and Stainless Steel Valves

Flanged: ■ CL150, CL300, or CL600 raised-face (RF) or ring-type joint (RTJ) flanges per ASME B16.5,

■ Raised-face (RF) flanges per EN1092-1/B
Screwed or Socket Welding: NPS 1/2 through 2, consistent with ASME B16.11

Buttwelding (schedule 40 or 80): NPS 1 through 4, consistent with ASME B16.25

Maximum Inlet Pressure and Temperatures^(1, 2)

As listed below, unless limited by maximum pressure drop or material temperature capabilities

Cast Iron Valves

Flanged: Consistent with CL125B or CL250B pressure-temperature ratings per ASME B16.1

Steel and Stainless Steel Valves

Flanged: Consistent with CL150, CL300, and CL600⁽³⁾ per ASME B16.34

Screwed or Welding: Consistent with CL600⁽³⁾ per ASME B16.34

Maximum Pressure Drops⁽²⁾

Same as maximum inlet pressure for specific construction defined above, except where further limited as shown in tables 8, 9, and 11. For soft seats on NACE service, see figure 4

Shutoff Classification Per ANSI/FCI 70-2 and IEC 60534-4

Metal Seating: Class IV is standard. Class V is optional
PTFE Composition Seating: Class VI

Construction Materials

Body and Bonnet: ■ Cast iron, ■ WCC steel, ■ CF8M (316 stainless steel), ■ WC9 chrome moly steel, or ■ other materials upon request

Trim Materials: See tables 3, 4, 5, and 15

All Other Parts: See tables 6 and 10

Material Temperature Capabilities⁽²⁾

Body-Trim Combinations: See table 7

Bolting for NACE MR0175 / ISO 15156 and MR0103: See table 17

All Other Parts: See tables 6 and 10

Flow Characteristics

■ Equal percentage, ■ quick opening, and ■ linear. With soft seat, equal percentage is standard

Flow Direction

Up through the seat ring

Flow Coefficients and Noise Level Predictions

See table 14 and Fisher Catalog 12

Port Diameters and Valve Plug Travels

See table 15

Yoke Boss and Stem Diameters

See table 15

Typical Bonnet Styles

■ Plain or ■ extension. See figure 6 for standard dimensions

■ ENVIRO-SEAL bellows seal bonnet. See figure 2. Also, see Bulletin 59.1:070, ENVIRO-SEAL Bellows Seal Bonnets ([D101641X012](#)) for more information.

- continued -

Product Bulletin

51.1:EZ

January 2017

EZ Valve

D100025X012

Specifications (continued)

Packing Arrangements

Standard Material: Single PTFE V-ring

Optional Materials: See table 6.

ENVIRO-SEAL Packing Systems: See figure 3.

ENVIRO-SEAL Packing Systems in vacuum service:
Standard ENVIRO-SEAL packing systems can be used in vacuum service with packing rings in standard orientation. Do not reverse the ENVIRO-SEAL PTFE packing rings. Also, see Bulletin 59.1:061, ENVIRO-SEAL Packing Systems for Sliding-Stem Valves ([D101633X012](#)) for more information.

Approximate Weights

NPS 1/2, 3/4 valves: 9 kg (20 lb)

NPS 1 valve: 11 kg (25 lb)

NPS 1-1/2 valve: 18 kg (40 lb)

NPS 2 valve: 36 kg (80 lb)

NPS 3 valve: 54 kg (120 lb)

NPS 4 valve: 75 kg (165 lb)

Valve Dimensions

See figure 6

■ ENVIRO-SEAL bellows seal bonnet dimensions, see figure 5

Optional Safety Instrumented System Classification

SIL3 capable — certified by exida Consulting LLC

Additional Options

■ Lubricator or ■ lubricator/isolating valve for packing lubrication and ■ valve body drain plug

1. EN (or other) ratings and end connections can usually be supplied; consult your Emerson Automation Solutions sales office.
2. Do not exceed the pressure/temperature limits in this bulletin. Any applicable standard or code limitations should not be exceeded.
3. Certain bonnet bolting material selections may require a CL600 easy-e valve assembly to be derated. Contact your Emerson Automation Solutions sales office for more information.

ENVIRO-SEAL Packing System Specifications

Applicable Stem Diameters

■ 9.5 mm (3/8 inches), ■ 12.7 (1/2), ■ 19.1 (3/4) diameter valve stems

Maximum Pressure/Temperature Limits⁽¹⁾

To Meet the EPA Fugitive Emission Standard of 100 PPM⁽²⁾

For ENVIRO-SEAL PTFE and ENVIRO-SEAL Duplex packing systems: full CL300 up to 232°C (450°F)

For ENVIRO-SEAL Graphite ULF packing: 104 bar (1500 psig) at 316°C (600°F)

Construction Materials

PTFE Packing Systems

Packing Ring and Lower Wiper: PTFE V-ring⁽³⁾

Male and Female Adaptor Rings: Carbon-filled PTFE V-ring

Graphite ULF Packing Systems: Graphite rings

Anti-Extrusion Washer: Filled PTFE (not required for Graphite ULF packing)

Lantern Ring: S31600 (316 stainless steel) (not required for Graphite ULF packing)

Packing Box Flange: S31600

Spring: ■ 17-7PH stainless steel or ■ N07718

Packing Follower: S31600 lined with carbon-filled PTFE

Packing Box Studs: Strain-hardened 316 stainless steel

Packing Box Nuts: 316 stainless steel SA194 Grade 8M

1. Refer to the valve specifications in this bulletin for pressure/temperature limits of valve parts. Do not exceed the pressure/temperature rating of the valve. Do not exceed any applicable code or standard limitation.
2. The Environmental Protection Agency (EPA) has set a limit of 100 parts per million (ppm) for fugitive emissions from a valve in selected VOC (Volatile Organic Compound) services.
3. In vacuum service, it is not necessary to reverse the ENVIRO-SEAL PTFE packing rings.

Figure 1. Fisher EZ Sectional with Optional Drain Plug

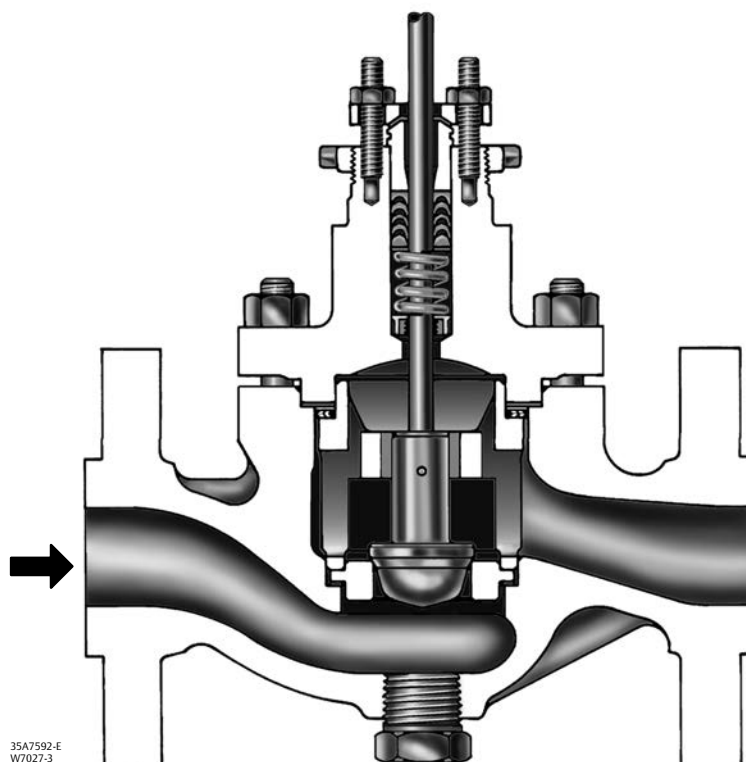

ENVIRO-SEAL, HIGH-SEAL Packing Systems

ENVIRO-SEAL and HIGH-SEAL packing systems offer exceptional sealing capabilities. These systems easily install in your existing valves or can be purchased with new valves. These systems offer an improved method of sealing your process to conserve valuable process fluid. The long-life and reliability of these systems also help to reduce your maintenance costs and downtime.

For applications requiring compliance with environmental protection regulations, the unique ENVIRO-SEAL packing system (figure 3) and, for hazardous service, the ENVIRO-SEAL bellows seal system (figure 2) are offered. The emission control

packing system helps to keep emission concentrations below the EPA 100 ppm requirement.

For an excellent stem seal in applications that are not environmentally-sensitive, the HIGH-SEAL Graphite ULF packing system (figure 3) is offered. The HIGH-SEAL packing system provides excellent sealing at pressure/temperature ratings beyond ENVIRO-SEAL limits. ENVIRO-SEAL systems may also be applied for excellent stem sealing in higher pressure/temperature applications not requiring EPA compliance.

ENVIRO-SEAL packing systems, available with PTFE, Graphite ULF, or duplex packing, and the HIGH-SEAL Graphite ULF packing system feature live-loading and unique packing-ring arrangements for long-term, consistent sealing performance.

ENVIRO-SEAL, HIGH-SEAL Features

- **Excellent Sealing Capabilities**-- The packing system provides excellent sealing, guiding, and transmission of loading force. The excellent sealing of the ENVIRO-SEAL system can control emissions to below the EPA (Environmental Protection Agency) minimum of 100 ppm (parts per million).
- **Improved Service Life**-- ENVIRO-SEAL and HIGH-SEAL system design, very smooth stem surface, and live-loading combine to give you long service with very low maintenance. The external live-loading provides a constant load over the life of the packing material, which greatly reduces your need for packing box adjustment and maintenance.
- **Easy Installation in Existing Valves**-- All parts needed to install the systems in existing valves are available in a convenient kit.
- **Adaptable to Many Applications**-- ENVIRO-SEAL systems are available with PTFE or Graphite ULF packing for 9.5 through 31.8 mm (3/8 through 1-1/4 inch) diameter valve stems. HIGH-SEAL systems with Graphite ULF packing are available for 9.5 through 50.8 mm (3/8 through 2-inch) diameter valve stems. Standard ENVIRO-SEAL packing systems can be used in vacuum service with packing rings in standard orientation. It is not necessary to reverse the ENVIRO-SEAL PTFE packing rings.

Figure 2. Fisher EZ Valve with ENVIRO-SEAL Bellows Seal Bonnet

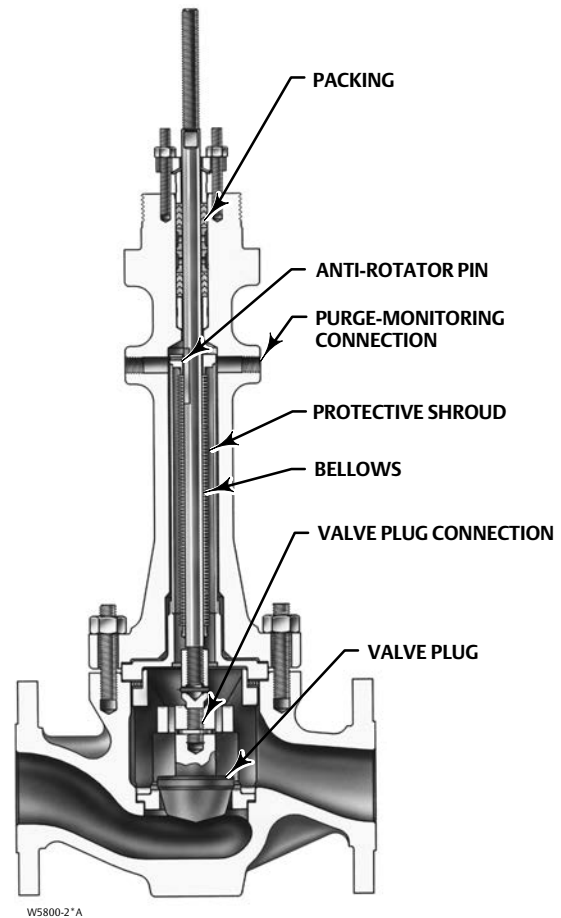
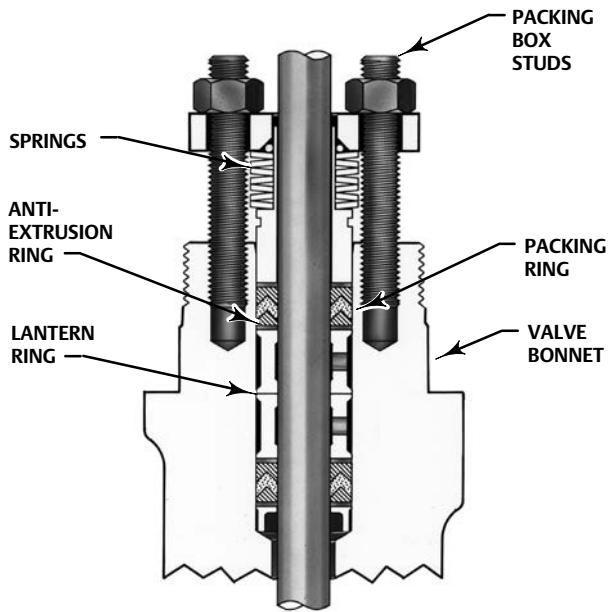
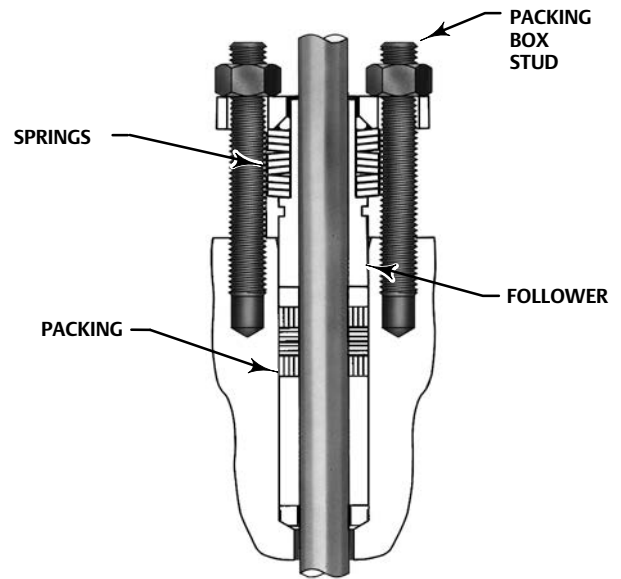

Figure 3. ENVIRO-SEAL and HIGH-SEAL Packing Systems



W5803-3

TYPICAL ENVIRO-SEAL PACKING SYSTEM WITH PTFE PACKING



W8532-1

TYPICAL ENVIRO-SEAL PACKING SYSTEM WITH GRAPHITE ULF PACKING

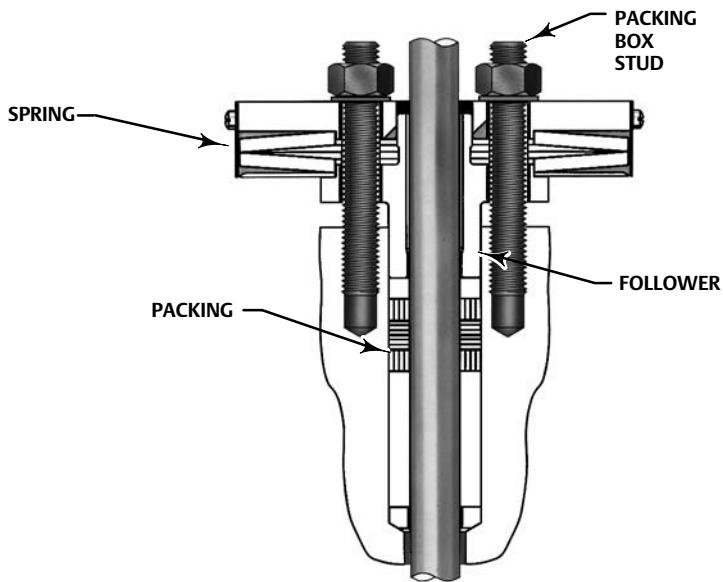

W8533-1

TYPICAL HIGH-SEAL PACKING SYSTEM WITH GRAPHITE ULF PACKING

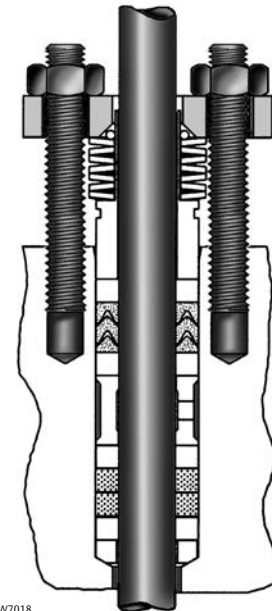

W7018

TYPICAL ENVIRO-SEAL PACKING SYSTEM WITH DUPLEX PACKING

Class VI Shutoff Capabilities

EZ valves with metal seat and PTFE soft seat constructions can provide ANSI/FCI Class VI shutoff capabilities. See tables 1 and 2.

Table 1. Class VI Shutoff Availability

Valve	Port Size, Inches	Seat	Minimum Seat Load
EZ	≤ 4	Metal	300 lbs/lineal inch
EZ	≤ 4	PTFE	See Catalog 14

Table 2. Class VI Trim Materials

VALVE	CAGE/SEAT RING RETAINER	VALVE PLUG	SEAT RING	TRIM TEMPERATURE LIMIT	
				°C	°F
EZ	CF8M (316 SST)	S31600/CoCr-A seat w/ standard beveled seat	S31600 w/ radiused seat (special design)	Not a limiting factor	Not a limiting factor
	CF8M	S31600/CoCr-A seat and guide w/ standard beveled seat	S31600 w/ radiused seat (special design)	Not a limiting factor	Not a limiting factor
	CF8M	S31600 w/ PTFE disk seat	S31600 w/ standard beveled seat	-29 to 149	-20 to 300
	CB7CU-1	S41600 w/ PTFE disk seat	S41600 w/ standard beveled seat	-29 to 204	-20 to 400

Figure 4. Pressure Drop / Temperature Capabilities for PTFE Seat Trim

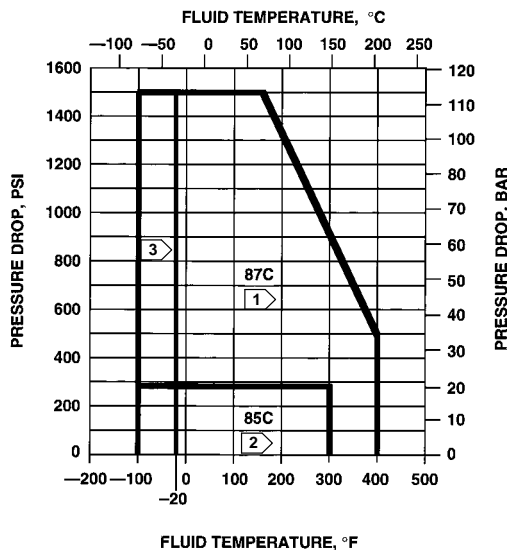

A6415-1

Notes:

1 Also applies to trims 101C, 127C, 137C, 151C, 153C, 154C, and 158C.

2 Also applies to trims 104C, 128C, 129C, 139C, 152C, 155C, 156C, and 157C.

3 Trim selections requiring Class VI shutoff are limited to -29°C (-20°F) minimum temperature. Some PTFE seat constructions can be used to -73°C (-100°F) minimum temperature if Class VI shutoff is not required. See table 7 for additional valve body/trim temperature limitations.

Micro-Flute Valve Plugs for Minimum Leakage

The EZ valve can be furnished with PTFE composition-seat Micro-Flute valve plugs for Class VI shutoff per ANSI/FCI 70-2 and IEC 60534-4.

These valve plugs are available on NPS 1/2 to 2 valves

with a 9.5 mm (3/8 inch) stem diameter, 9.5 mm (3/8 inch) actuator-stem connection, and 6.4 mm (0.25 inch) seat ring port diameter. These plugs have the same flow coefficients as standard Micro-Flute plugs. Standard seat rings are used.

The valve plugs have a screwed retainer that holds the seat disk and valve plug tip to the valve stem.

Table 3. Material Cross Reference

Standard Designation	Other Designation	Standard Designation	Other Designation
CB7Cu-1	17-4 PH Stainless Steel, Cast	WC9	Chrome-Moly Steel, Cast
S17400	17-4 PH Stainless Steel	N04400	Alloy 400
CF8M	316 Stainless Steel, Cast	N05500	Alloy K500
S31600	316 Stainless Steel	M35-1	Alloy 400 Cast
CoCr-A	Alloy 6 Hardfacing	S31603	316L Stainless Steel
R30006	Alloy 6, Cast	S41600	416 Stainless Steel
Alloy 6B	Alloy 6, Wrought	WCC	WCC Steel, Cast

Table 4. Typical Combinations of Metal Trim Parts for Equal Percentage (Including Micro-Form), Linear, and Quick Opening Valve Plugs

Trim Designation	Valve Plug	Valve Stem	Seat Ring	Seat Ring Retainer	Disk Seat and Retainer for Optional PTFE-Seat Construction	Guide Bushing
101 ⁽¹⁾	S41600 (416 stainless steel) hardened	S31600 (316 stainless steel)	S41600 hardened	CB7Cu-1 (17-4 PH stainless steel)	S41600	S17400 (17-4 PH stainless steel)
104	S31600 (316 stainless steel)	S31600	S31600	CB7Cu-1	S31600	S17400
120	N05500	N05500	N05500	M35-1	N05500	N05500
127 and 127H ⁽³⁾	S31600 w/CoCr-A seat & guide	S31600	S31600 w/CoCr-A seat	CF8M (316 stainless steel)	---	Alloy 6B
128	S31600 w/CoCr-A seat	S31600	S31600 w/CoCr-A seat	CF8M	---	Alloy 6B
129 ⁽²⁾	S31600	S31600	S31600	CF8M	S31600	Alloy 6B
137	S31600 w/CoCr-A seat & guide	S31600	S31600 w/CoCr-A seat	CB7Cu-1	---	S17400
139	S31600 w/CoCr-A seat	S31600	S31600 w/CoCr-A seat	CB7Cu-1	---	S17400

1. Standard trim for cast iron, WCC, and WC9 valve bodies, except Micro-Flow and Micro-Flute.
2. Standard trim for CF8M valve body.
3. Utilizes special welded seat ring retainer-guide bushing assembly required for high temperature service.

Table 5. Typical Combinations of Metal Trim Parts for Micro-Flute and Micro-Flow Valve Plugs (These Constructions Do Not Use Guide Bushing)

Trim Designation	Valve Plug	Valve Stem	Seat Ring	Seat Ring Retainer	Disk Seat and Retainer for Optional PTFE-Seat Construction ⁽¹⁾
151	S41600 (416 SST) hardened	S31600 (316 stainless steel)	S41600 hardened	CB7Cu-1 (17-4 PH stainless steel)	---
152 ⁽²⁾	S31600 (316 SST) w/CoCr-A seat, R30006 tip	S31600	S31600	CB7Cu-1	S31600
153	N05500	N05500	N05500	M35-1	N05500
154	S31600 w/CoCr-A seat, R30006 tip	S31600	S31600 w/CoCr-A seat & bore	CF8M (316 stainless steel)	---
155	S31600 w/CoCr-A seat, R30006 tip	S31600	S31600 w/CoCr-A seat ⁽³⁾	CF8M	---
156	S31600 w/CoCr-A seat, R30006 tip	S31600	S31600	CF8M	S31600
157	S31600 w/CoCr-A seat, R30006 tip	S31600	S31600 w/CoCr-A seat ⁽³⁾	CB7Cu-1	---
158	S31600 w/CoCr-A seat, R30006 tip	S31600	S31600 w/CoCr-A seat & bore	CB7Cu-1	---

1. Micro-Flute constructions.
2. Standard trim for Micro-Flow and Micro-Flute constructions in cast iron, WCC, CF8M, and WC9 valve bodies.
3. Micro-Flute and Micro-Flow valve plugs have a CoCr-A seat and R30006 tip, but are not recommended for erosive service without the additional use of CoCr-A on the seat and bore of the seat ring.

Table 6. Construction Materials and Temperature Limits

PART		MATERIAL	TEMPERATURE CAPABILITIES					
			°C		°F			
Body-to-bonnet bolting. See table 17 for NACE bolting materials and temperatures	Cast iron valve body	Cap screws	Steel SAE Grade 5		-29	232 ⁽¹⁾	-20	450 ⁽¹⁾
	WCC steel body	Studs	Steel SA-193-B7		-29	427	-20	800
		Nuts	Steel SA-194-2H (lubricated)		-29	427	-20	800
	CF8M (316 stainless steel) body	Studs	Steel SA-193-B7 (standard)		-48	427	-55	800
		Nuts	Steel SA-194-2H (standard)		-48	427	-55	800
		Studs	304 stainless steel SA-320-B8		-198	38	-325	100
		Nuts	304 stainless steel SA-194-8		-198	38	-325	100
	Studs	316 stainless steel SA-193-B8M (strain hardened)		-198	427	-325	800	
Nuts	316 stainless steel SA-194-8M (lubricated)		-198	427	-325	800		
Seat disk (optional)		PTFE	-73	204	-100	400		
Bonnet and seat ring gasket		S31600 (316 stainless steel)/graphite ⁽²⁾	-198	593 ⁽⁴⁾	-325	1100 ⁽⁴⁾		
		PTFE-coated N04400 (optional for trim 120)	-73	149	-100	300		
Spiral wound gaskets		N04400/PTFE (optional for trims 120 & 153)	-73	149	-100	300		
		N06600/graphite (FGM) standard	-198	593 ⁽⁴⁾	-325	1100 ⁽⁴⁾		
Shim		S31600	These materials not limiting factors					
		N04400 (standard for trims 120 & 153)	These materials not limiting factors					
Packing flange studs and nuts when used with std bonnet		S31600	-198	593	-325	1100		
Packing (temperatures shown are material temperature capabilities). See table 8 for proper bonnet selection		PTFE V-ring	-40	232	-40	450		
		PTFE/composition	-73	232	-100	450		
		Graphite ribbon/filament	-198	538 ⁽⁵⁾	-325	1000 ⁽⁵⁾		
		Graphite ribbon for high-temperature oxidizing service	-198	649	-325	1200		
Packing follower		S31600 ⁽²⁾	-198	593	-325	1100		
		N04400 (optional for trims 120 & 153)	-198	482	-325	900		
Packing spring		S31600	-198	593	-325	1100		
Lantern ring (for double packing)		S31600 ⁽³⁾	-198	593	-325	1100		
		N04400 (standard for trims 120 & 153)	-198	482	-325	900		
Packing box ring		S31600 ⁽³⁾	-198	593	-325	1100		
		N04400	-198	482	-325	900		

1. Temperature limit for bodies with screwed end connections is 208°C (406°F).
2. Standard for all trim.
3. Standard for all trim except for trim 120 and 153.
4. Except 427°C (800°F) for oxidizing service.
5. Except 371°C (700°F) for oxidizing service.

Table 7. Valve Body/Trim Temperature Capabilities for Metal Trim Parts

VALVE BODY MATERIAL	VALVE BODY SIZE, NPS	TEMPERATURE CAPABILITIES											
		Trim for Equal Percentage (Including Micro-Form), Linear, and Quick Opening Valve Plugs					Trim for Micro-Flute and Micro-Flow Valve Plugs						
		Trim Designation	°C		°F		Trim Designation	°C		°F			
Min	Max		Min	Max	Min	Max		Min	Max				
Cast iron	1/2, 3/4, 1, 1-1/2, or 2	101	-29	232	-20	450	151	-29	232	-20	450		
		120	-73	232	-100	450	153	-73	232	-100	450		
		87, 127, 137	-73	232	-100	450	154, 158	-73	232	-100	450		
		85, 86, 128, 129	-73	232 ⁽¹⁾	-100	450 ⁽¹⁾	---	---	---	---	---		
		139, 104	-73	232 ⁽¹⁾	-100	450 ⁽¹⁾	152, 155, 156, 157	-73	149	-100	300		
		101	-29	232	-20	450	---	---	---	---	---		
	3 or 4	104, 139	-73	232 ⁽¹⁾	-100	450 ⁽¹⁾	---	---	---	---	---		
		120	-73	232	-100	450	---	---	---	---	---		
		87, 127	-73	232	-100	450	---	---	---	---	---		
		85, 86, 128, 129	-73	232 ⁽¹⁾	-100	450 ⁽¹⁾	---	---	---	---	---		
		137	-73	232	-100	450	---	---	---	---	---		
		101	-29	427	-20	800	151	-29	316	-20	600		
		WCC steel	1/2, 3/4, 1, 1-1/2, or 2	104, 139	-29	427 ⁽¹⁾	-20	800 ⁽¹⁾	152, 157	-29	149	-20	300
				120	-29	316	-20	600	153	-29	316	-20	600
87, 127	-29			260	-20	500	154	-29	427	-20	800		
86, 128	-29			260 ⁽¹⁾	-20	500 ⁽¹⁾	---	---	---	---	---		
85, 129	-29			260 ⁽¹⁾	-20	500 ⁽¹⁾	156	-29	149	-20	300		
137, 127H	-29			427	-20	800	158	-29	427	-20	800		
101, 127H	-29			427	-20	800	---	---	---	---	---		
3	104, 139		-29	371 ⁽¹⁾	-20	700 ⁽¹⁾	---	---	---	---	---		
	120		-29	316	-20	600	---	---	---	---	---		
	87, 127		-29	371	-20	700	---	---	---	---	---		
	85, 86, 128, 129		-29	371 ⁽¹⁾	-20	700 ⁽¹⁾	---	---	---	---	---		
	137		-29	371	-20	700	---	---	---	---	---		
	101		-29	427	-20	800	---	---	---	---	---		
4	104, 139		-29	371 ⁽¹⁾	-20	700 ⁽¹⁾	---	---	---	---	---		
	120	-29	316	-20	600	---	---	---	---	---			
	87, 127, 127H	-29	338	-20	640	---	---	---	---	---			
	85, 86, 128, 129	-29	338 ⁽¹⁾	-20	640 ⁽¹⁾	---	---	---	---	---			
	137	-29	371	-20	700	---	---	---	---	---			
	101	-29	354	-20	670	151	-29	316	-20	600			
	CF8M (316 stainless steel)	1/2, 3/4, 1, or 1-1/2	104	-101	371 ⁽¹⁾	-150	700 ⁽¹⁾	152	-101	149	-150	300	
120			-198	316	-325	600	153	-198	316	-325	600		
87, 127			-198	260	-325	500	154	-198	593	-325	1100		
127H ⁽³⁾			-198	593	-325	1100	---	---	---	---	---		
86, 128			-198	260 ⁽¹⁾	-325	500 ⁽¹⁾	---	---	---	---	---		
85, 129			-198	260 ⁽¹⁾	-325	500 ⁽¹⁾	156	-198	149	-325	300		
137			-101	371	-150	700	158	-101	371	-150	700		
139			-101	371 ⁽¹⁾	-150	700 ⁽¹⁾	157	-101	149	-150	300		
2			101	-29	288	-20	550	151	-29	288	-20	550	
			104	-101	299 ⁽¹⁾	-150	570 ⁽¹⁾	152	-101	149	-150	300	
		120	-198	316	-325	600	153	-198	316	-325	600		

-continued-

Table 7. Valve Body/Trim Temperature Capabilities for Metal Trim Parts (Continued)

VALVE BODY MATERIAL	VALVE BODY SIZE, NPS	TEMPERATURE CAPABILITIES										
		Trim for Equal Percentage (Including Micro-Form), Linear, and Quick Opening Valve Plugs					Trim for Micro-Flute and Micro-Flow Valve Plugs					
		Trim Designation	°C		°F		Trim Designation	°C		°F		
Min	Max		Min	Max	Min	Max		Min	Max			
CF8M (316 stainless steel)	2	87, 127	-198	260	-325	500	154	-198	593	-325	1100	
		127H ⁽³⁾	-198	593	-325	1100	---	---	---	---	---	
		86, 128	-198	260 ⁽¹⁾	-325	500 ⁽¹⁾	---	---	---	---	---	
		85, 129	-198	260 ⁽¹⁾	-325	500 ⁽¹⁾	156	-198	149	-325	300	
		137	-101	299	-150	570	158	-101	299	-150	570	
		139	-101	299 ⁽¹⁾	-150	570 ⁽¹⁾	157	-101	149	-150	300	
	3	101	-29	216	-20	420	---	---	---	---	---	
		104, 139	-101	227 ⁽¹⁾	-150	440 ⁽¹⁾	---	---	---	---	---	
		120	-198	316	-325	600	---	---	---	---	---	
		87, 127	-198	377	-325	700	---	---	---	---	---	
		127H ⁽³⁾	-198	593	-325	1100	---	---	---	---	---	
		85, 86, 128, 129	-198	377 ⁽¹⁾	-325	700 ⁽¹⁾	---	---	---	---	---	
	4	137	-101	227	-150	440	---	---	---	---	---	
		101	-29	177	-20	350	---	---	---	---	---	
		104, 139	-101	182 ⁽¹⁾	-100	360 ⁽¹⁾	---	---	---	---	---	
		120	-198	316	-325	600	---	---	---	---	---	
		87, 127	-198	371	-325	700	---	---	---	---	---	
		127H ⁽³⁾	-198	593	-325	1100	---	---	---	---	---	
	WC9 chrome moly steel	1/2, 3/4, 1, 1-1/2, or 2	85, 86, 128, 129	-198	371 ⁽¹⁾	-325	700 ⁽¹⁾	---	---	---	---	---
			137	-101	182	-150	360	---	---	---	---	---
			101	-29	427	-20	800	151	-29	316	-20	600
104			-29	427 ⁽¹⁾	-20	800 ⁽¹⁾	152	-29	149	-20	300	
120			-29	316	-20	600	153	-29	316	-20	600	
87, 127			-29	260	-20	500	154	-29	565	-20	1050 ⁽²⁾	
127H			-29	565	-20	1050	---	---	---	---	---	
86, 128			-29	260 ⁽¹⁾	-20	500 ⁽¹⁾	---	---	---	---	---	
85, 129			-29	260 ⁽¹⁾	-20	500 ⁽¹⁾	156	-29	149	-20	300	
3		137	-29	427	-20	800	158	-29	427	-20	800 ⁽¹⁾	
		139	-29	427 ⁽¹⁾	-20	800 ⁽¹⁾	157	-29	149	-20	300	
		101	-29	427	-20	800	---	---	---	---	---	
		104, 139	-29	371 ⁽¹⁾	-20	700 ⁽¹⁾	---	---	---	---	---	
		120	-29	316	-20	600	---	---	---	---	---	
		87, 127	-29	343	-20	650	---	---	---	---	---	
		127H	-29	510	-20	950	---	---	---	---	---	
		85, 86, 128, 129	-29	343 ⁽¹⁾	-20	650 ⁽¹⁾	---	---	---	---	---	
		137	-29	371	-20	700	---	---	---	---	---	
4		101	-29	427	-20	800	---	---	---	---	---	
		104, 139	-29	371 ⁽¹⁾	-20	700 ⁽¹⁾	---	---	---	---	---	
		120	-29	316	-20	600	---	---	---	---	---	
	87, 127	-29	316	-20	450	---	---	---	---	---		
	127H	-29	338	-20	640	---	---	---	---	---		
	85, 86, 128, 129	-29	232 ⁽¹⁾	-20	450 ⁽¹⁾	---	---	---	---	---		
137	-29	371	-20	700	---	---	---	---	---			

1. With non-lubricating fluids, temperature is limited to 149°C (300°F).
 2. For NPS 2 valve body, maximum temperature is 466°C (870°F).
 3. May be used up to 593°C (1100°F) if manufacturing process controls carbon content to 0.04% minimum or 0.08% maximum.

Table 8. Bonnet Selection Guidelines

BONNET STYLE	PACKING MATERIAL	IN-BODY PROCESS TEMPERATURE LIMITS ⁽¹⁾	
		°C	°F
Plain: ■ Standard for NPS 1/2, 3/4, 1, and 1-1/2 inch valves with 2-1/8 inch yoke boss diameter ■ Standard for NPS 2, 3, and 4 valves with 2-13/16 inch yoke boss diameter ■ Optional for NPS 2, 3, and 4 valves with 3-9/16 inch yoke boss diameter	PTFE V-ring	-18 to 232	0 to 450
	PTFE/Composition	-18 to 232	0 to 450
	Graphite ribbon/filament	-18 to maximum shown in table 6	0 to maximum shown in table 6
Style 1 Cast Extension: ■ Optional for all valve sizes. Check yoke boss diameter	PTFE V-ring	-46 to 427	-50 to 800
	PTFE/Composition		
	Graphite ribbon/filament	-46 to maximum shown in table 6	-50 to maximum shown in table 6
Style 2 Cast Extension: ■ Optional for all valve sizes. Check yoke boss diameter	PTFE V-ring	-101 to 427	-150 to 800
	PTFE/Composition		
	Graphite ribbon/filament	-101 to maximum shown in table 6	-150 to maximum shown in table 6
ENVIRO-SEAL bellows seal bonnet	PTFE	For exceptional stem sealing capabilities. See Bulletin 59.1:070, ENVIRO-SEAL Bellows Seal Bonnets (D101641X012) for pressure/temperature ratings.	
	Graphite	For exceptional stem sealing capabilities. See Bulletin 59.1:070, ENVIRO-SEAL Bellows Seal Bonnets (D101641X012) for pressure/temperature ratings.	

1. These in-body process temperatures assume an outside, ambient temperature of 21°C (70°F) and no insulation on the bonnet. When using any packing at low process temperatures, a cast extension bonnet may have to be used to prevent packing damage which could result from the formation of valve stem frost. Material selection for trim and other components will also be limiting factors.

Table 9. Maximum Allowable Pressure Drops per Trim Designation for Equal Percentage (Including Micro-Form), Linear, and Quick Opening Valve Plugs

TRIM DESIGNATION	VALVE PLUG	VALVE STEM	SEAT RING	SEAT RING RETAINER	GUIDE BUSHING	SHUTOFF PRESSURE DROP		FLOWING PRESSURE DROP	
						Bar	Psig	Bar	Psid
101	S41600 (416 stainless steel) hardened	S31600 (316 stainless steel)	S41600 hardened	CB7Cu-1 (17-4 PH stainless steel)	S17400 (17-4 PH stainless steel)	103	1500	103	1500
104	S31600 (316 stainless steel)	S31600	S31600	CB7Cu-1	S17400	21	300 ⁽¹⁾	103	1500
120	N05500	N05500	N05500	M35-1	N05500	55	800 ⁽¹⁾	103	1500
87, 127, 127H	S31600 w/CoCr-A seat & guide	S31600	S31600 w/CoCr-A seat	CF8M (316 stainless steel)	Alloy 6B	103	1500	103	1500
86, 128	S31600 w/CoCr-A seat	S31600	S31600 w/CoCr-A seat	CF8M	Alloy 6B	103	1500	103	1500
85, 129	S31600	S31600	S31600	CF8M	Alloy 6B	21	300 ⁽¹⁾	103	1500
137	S31600 w/CoCr-A seat & guide	S31600	S31600 w/CoCr-A seat	CB7Cu-1	S17400	103	1500	103	1500
139	S31600 w/CoCr-A seat	S31600	S31600 w/CoCr-A seat	CB7Cu-1	S17400	103	1500	103	1500

1. Trims 104, 120, and 129 may be used up to 103 bar (1500 psid) with clean dry gas.

Table 10. Maximum Allowable Pressure Drops per Trim Designation for Micro-Flute and Micro-Flow Valve Plugs

TRIM DESIGNATION	VALVE PLUG	VALVE STEM	SEAT RING	SEAT RING RETAINER	SHUTOFF PRESSURE DROP		FLOWING PRESSURE DROP	
					Bar	Psig	Bar	Psid
151	S41600 (416 stainless steel) hardened	S31600 (316 stainless steel)	S41600 hardened	CB7Cu-1 (17-4 PH stainless steel)	103	1500	103	1500
152	S31600 (316 stainless steel) w/CoCr-A seat, R30006 tip	S31600	S31600	CB7Cu-1	21	300 ⁽¹⁾	103	1500
153	N05500	N05500	N05500	M35-1	55	800 ⁽¹⁾	103	1500
87, 154	S31600 w/CoCr-A seat, R30006 tip	S31600	S31600 w/CoCr-A seat & bore	CF8M (316 stainless steel)	103	1500	103	1500
155	S31600 w/CoCr-A seat, R30006 tip	S31600	S31600 w/CoCr-A seat	CF8M	103	1500	103	1500
85, 156	S31600 w/CoCr-A seat, R30006 tip	S31600	S31600	CF8M	21	300 ⁽¹⁾	103	1500
157	S31600 w/CoCr-A seat, R30006 tip	S31600	S31600 w/CoCr-A seat	CB7Cu-1	103	1500	103	1500
158	S31600 w/CoCr-A seat, R30006 tip	S31600	S31600 w/CoCr-A seat & bore	CB7Cu-1	103	1500	103	1500

1. Trims 152, 153, and 156 may be used up to 103 bar (1500 psid) with clean dry gas.

Table 11. Gasket Selection Guidelines⁽¹⁾

Gasket Set	Seat Ring Gasket	Bonnet Gasket	Spiral Wound Gasket	Shim	Temperature Capabilities
2 ⁽²⁾	316 SST/graphite flat sheet	316 SST/graphite flat sheet	N06600/graphite	S31600	-198 to 593°C ⁽³⁾ (-325 to 1100°F) ⁽³⁾
3	PTFE-coated N04400	PTFE-coated N04400	N04400/PTFE	N04400	-73 to 149°C (-100 to 300°F)

1. See Bulletin 59.1:070, ENVIRO-SEAL Bellows Seal Bonnets ([D101641X012](#)) for bellows gasket information.
2. FGM gasket set.
3. Except 427°C (800°F) for oxidizing service.

Table 12. Maximum Allowable Pressure Drops (Flow Up Only)⁽¹⁾ for Gasket Materials (NPS 1/2 through 1-1/2 Valves)

TEMPERATURE, °C ⁽⁴⁾⁽⁵⁾	BAR ⁽²⁾⁽³⁾										
	Valve Body Size, NPS										
	1/2, 3/4, & 1					1-1/2					
	Port Diameter, mm										
	4.8 & 6.4	9.5	12.7	19.1	25.4	4.8 & 6.4	9.5	12.7	19.1	25.4	38.1
N04400/Composition Spiral Wound Gasket (Gasket Set 4)											
-253 to 38	67.6	68.3	69.0	72.4	76.5	58.6	59.0	59.3	61.3	63.4	72.4
93	56.5	57.2	57.9	60.0	64.1	49.0	49.3	49.6	51.0	53.1	60.0
149	47.6	48.3	49.0	51.0	53.8	41.4	41.8	42.1	43.4	44.8	51.0
204	43.4	43.8	44.1	46.2	49.0	37.9	37.9	37.9	39.3	40.7	46.2
232	42.1	42.6	43.1	44.8	47.6	36.5	36.7	36.9	38.3	39.6	44.8
N06600/Graphite Spiral Wound Gasket (Gasket Set 2) or N04400/PTFE Spiral Wound Gasket (Gasket Set 3)⁽⁵⁾											
-253 to 38	94.5	96.2	97.9	104.1	114	77.9	79.0	80.0	82.7	87.6	105
93	89.6	91.4	93.1	98.6	108	73.8	74.5	75.2	78.6	82.7	99.3
149	85.5	87.2	88.9	94.5	103	70.3	71.4	72.4	75.2	79.3	94.5
204	81.4	83.1	84.8	89.6	98.6	66.9	68.0	69.0	71.0	75.2	90.3
260	78.6	80.4	82.1	86.9	95.2	64.8	65.5	66.2	69.0	73.1	87.6
316	76.5	77.9	79.3	84.1	92.4	62.7	63.4	64.1	66.9	71.0	84.8
371	73.8	75.2	76.5	81.4	88.9	60.7	61.4	62.1	64.8	68.3	81.4
427	71.0	72.4	73.8	78.6	86.2	58.6	59.3	60.0	62.1	66.2	78.6
TEMPERATURE, °F ⁽⁴⁾⁽⁵⁾	PSI ⁽²⁾⁽³⁾										
	Port Diameter, Inches										
	0.1875 & 0.25	0.375	0.5	0.75	1	0.1875 & 0.25	0.375	0.5	0.75	1	1.5
N04400/Composition Spiral Wound Gasket (Gasket Set 4)											
-425 to 100	980	990	1000	1050	1110	850	855	860	890	920	1050
200	820	830	840	870	930	710	715	720	740	770	870
300	690	700	710	740	780	600	605	610	630	650	740
400	630	635	640	670	710	550	550	550	570	590	670
450	610	618	625	650	690	530	535	535	555	575	650
N06600/Graphite Spiral Wound Gasket (Gasket Set 2) or N04400/PTFE Spiral Wound Gasket (Gasket Set 3)⁽⁵⁾											
-425 to 100	1370	1395	1420	1510	1660	1130	1145	1160	1200	1270	1520
200	1300	1325	1350	1430	1570	1070	1080	1090	1140	1200	1440
300	1240	1265	1290	1370	1500	1020	1035	1050	1090	1150	1370
400	1180	1205	1230	1300	1430	970	985	1000	1030	1090	1310
500	1140	1165	1190	1260	1380	940	950	960	1000	1060	1270
600	1110	1130	1150	1220	1340	910	920	930	970	1030	1230
700	1070	1090	1110	1180	1290	880	890	900	940	990	1180
800	1030	1050	1070	1140	1250	850	860	870	900	960	1140

1. EZ should not be used in flow down service including on-off applications.
2. Pressure drop cannot exceed maximum inlet pressure as indicated in the Specifications section.
3. The trim may be further limited by maximum inlet pressure drops listed in tables 9 and 10.
4. Pressure drops at intermediate temperatures may be interpolated.
5. Maximum temperature capability of PTFE-coated N04400 gaskets as used in gasket set 3 is 149°C (300°F).

Table 13. Maximum Allowable Pressure Drops (Flow Up Only)⁽¹⁾ for Gasket Materials (NPS 2 through 4 Valves)

TEMPERATURE, °C ⁽⁴⁾⁽⁵⁾	BAR ⁽²⁾⁽³⁾									
	Valve Body Size, NPS									
	2					3			4	
	Port Diameter, mm									
	4.8 & 6.4	9.5	12.7	19.1	25.4	50.8	50.8	76.2	50.8	101.6
N04400/Composition Spiral Wound Gasket (Gasket Set 4)										
-253 to 38	52.4	52.8	53.1	54.5	55.8	70.3	55.2	70.3	49.0	73.8
93	43.4	43.8	44.1	45.5	46.9	58.6	46.2	58.6	40.7	61.4
149	37.2	37.2	37.2	37.9	39.3	49.6	38.6	49.6	34.5	51.7
204	33.8	33.8	33.8	34.5	35.9	44.8	35.2	45.5	31.0	46.9
232	32.8	32.8	32.8	33.4	34.8	43.4	34.1	44.1	30.3	45.5
N06600/Graphite Spiral Wound Gasket (Gasket Set 2) or N04400/PTFE Spiral Wound Gasket (Gasket Set 3)⁽⁵⁾										
-253 to 38	67.6	68.2	68.7	70.3	73.1	101	69.6	97.2	65.5	114
93	63.4	64.1	64.8	66.9	69.6	95.8	66.2	92.4	62.1	108
149	60.7	61.4	62.1	63.4	66.2	91.7	62.7	88.3	58.6	103
204	57.9	58.3	58.6	60.7	62.7	86.9	60.0	83.4	55.8	97.9
260	55.8	56.5	57.2	58.6	61.4	84.1	57.9	81.4	54.5	94.5
316	54.5	54.9	55.2	56.5	59.3	81.4	56.5	78.6	52.4	91.7
371	52.4	52.8	53.1	55.2	57.2	78.6	54.5	75.8	51.0	88.3
427	50.3	51.0	51.7	53.1	55.2	75.8	52.4	73.1	49.0	85.5
TEMPERATURE, °F ⁽⁴⁾⁽⁵⁾	PSI ⁽²⁾⁽³⁾									
	Port Diameter, Inches									
	0.1875 & 0.25	0.375	0.5	0.75	1	2	2	3	2	4
N04400/Composition Spiral Wound Gasket (Gasket Set 4)										
-425 to 100	760	765	770	790	810	1020	800	1020	710	1070
200	630	635	640	660	680	850	670	850	590	890
300	540	540	540	550	570	720	560	720	500	750
400	490	490	490	500	520	650	510	660	450	680
450	475	475	475	485	505	630	495	640	440	660
N06600/Graphite Spiral Wound Gasket (Gasket Set 2) or N04400/PTFE Spiral Wound Gasket (Gasket Set 3)⁽⁵⁾										
-425 to 100	980	985	990	1020	1060	1470	1010	1410	950	1650
200	920	930	940	970	1010	1390	960	1340	900	1560
300	880	890	900	920	960	1330	910	1280	850	1490
400	840	845	850	880	910	1260	870	1210	810	1420
500	810	820	830	850	890	1220	840	1180	790	1370
600	790	795	800	820	860	1180	820	1140	760	1330
700	760	765	770	800	830	1140	790	1100	740	1280
800	730	740	750	770	800	1100	760	1060	710	1240

1. EZ should not be used in flow down service including on-off applications.
 2. Pressure drop cannot exceed maximum inlet pressure as indicated in the Specifications section.
 3. The trim may be further limited by maximum inlet pressure drops listed in tables 9 and 10.
 4. Pressure drops at intermediate temperatures may be interpolated.
 5. Maximum temperature capability of PTFE-coated N04400 gaskets as used in gasket set 3 is 149°C (300°F).

Table 14. Maximum Flow Coefficient for Full-Sized Trim with Equal Percentage Characteristic and Normal Flow Direction⁽¹⁾

Valve Body Size, NPS	C _v at Max Valve Plug Travel
1/2	4.47
3/4	9.00
1	13.2
1-1/2	28.1
2	53.8
3	114
4	190

1. Flow coefficients for linear and quick-opening valve plugs normally are somewhat greater.

Table 15. Port Diameters, Valve Plug Travel, and Stem and Yoke Boss Diameters

VALVE BODY SIZE, NPS	PORT DIAMETER, mm			MAX VALVE PLUG TRAVEL, mm	VALVE STEM AND YOKE BOSS DIAMETERS, mm				
	Equal Percentage ⁽¹⁾	Quick Opening	Linear		Standard		Optional		
					Stem	Yoke Boss	Stem	Yoke Boss	
1/2 or 3/4	4.8 ⁽²⁾ , 6.4 ⁽³⁾ , 9.5, 12.7, 19.1, 25.4	25.4	---	19	9.5	54	12.7	71	
1	4.8 ⁽²⁾ , 6.4 ⁽³⁾ , 9.5, 12.7, 19.1, 25.4	25.4	25.4						
1-1/2	4.8 ⁽²⁾ , 6.4 ⁽³⁾ , 9.5, 12.7, 19.1, 25.4, 38.1	38.1	38.1						
2	4.8 ⁽²⁾ , 6.4 ⁽³⁾ , 9.5, 12.7, 19.1, 25.4, 50.8	50.8	50.8	29	12.7	71	19.1	90	
3	50.8, 76.2	76.2	76.2	38					
4	50.8, 101.6	101.6	101.6	51					
Inches									
1/2 or 3/4	0.1875 ⁽²⁾ , 0.25 ⁽³⁾ , 0.375, 0.5, 0.75, 1	1	---	0.75	3/8	2-1/8	1/2	2-13/16	
1	0.1875 ⁽²⁾ , 0.25 ⁽³⁾ , 0.375, 0.5, 0.75, 1	1	1						
1-1/2	0.1875 ⁽²⁾ , 0.25 ⁽³⁾ , 0.375, 0.5, 0.75, 1, 1.5	1.5	1.5						
2	0.1875 ⁽²⁾ , 0.25 ⁽³⁾ , 0.375, 0.5, 0.75, 1, 2	2	2	1.125	1/2	2-13/16	3/4	3-9/16	
3	2, 3	3	3	1.5					
4	2, 4	4	4	2					

1. 6.4 through 19.1 mm (0.25 through 0.75-inch) port diameters use Micro-Form valve plug.
2. Micro-Flow valve plug.
3. Also available in 1-flute and 3-flute Micro-Flute valve plugs.

Table 16. Typical Combinations of Metal Trim Parts for Equal Percentage (Including Micro-Form), Linear, and Quick Opening Valve Plugs for Compatibility with NACE MR0175 / ISO 15156 and MR0103 Specifications (Environmental Restrictions Apply, Refer to Standard)

Trim Designation	Valve Plug	Seat Ring Retainer	Bushing	Seat Ring	Valve Stem, Packing Follower, Lantern Ring, Packing Box Ring, Pins, and Disk Retainer
85	S31600 (316 stainless steel)	CF8M (316 stainless steel)	Alloy 6B	S31600	S20910 (Valve Stem) S31600 (All Other Parts)
85C ⁽¹⁾	S31600/PTFE	CF8M	Alloy 6B	S31600	
86	S31600 w/CoCr-A seat	CF8M	Alloy 6B	Alloy 6	
87	S31600 w/CoCr-A seat & guide	CF8M	Alloy 6B	Alloy 6	
87C ⁽¹⁾	S31600/PTFE w/CoCr-A guide	CF8M	Alloy 6B	Alloy 6	

1. 85C and 87C are trims for PTFE-seat construction.

Table 17. Bolting Materials and Temperature Limits for Bolting Compliance with NACE MR0175-2002, NACE MR0175/ISO 15156, and NACE MR0103 (Environmental Restrictions May Apply)

VALVE BODY MATERIAL	BOLTING MATERIAL	TEMPERATURE CAPABILITIES					
		°C		°F			
		Min	Max	Min	Max		
Non-exposed bolting (Standard)							
WCC and CF8M (316 SST)	Studs	Steel SA-193-B7		-48 ⁽¹⁾	427	-55 ⁽¹⁾	800
	Nuts	Steel SA-194-2H					
Exposed bolting (Optional) Requires Derating of Valve⁽²⁾ When These Body-to-Bonnet Bolting Materials are Used							
WCC and CF8M	Studs	Steel SA-193-B7M		-48 ⁽¹⁾	427	-55 ⁽¹⁾	800
	Nuts	Steel SA-194-2HM					

1. -29°C (-20°F) with WCC valve body material.
2. Derating is not required for CL300 valves. Derating is required for valves rated at CL600 and above. Contact your Emerson Automation Solutions sales office for assistance in determining the derating of valves when these body-to-bonnet bolting materials are used.

Figure 5. ENVIRO-SEAL Bellows Seal Bonnet Dimensions (also see table 18)

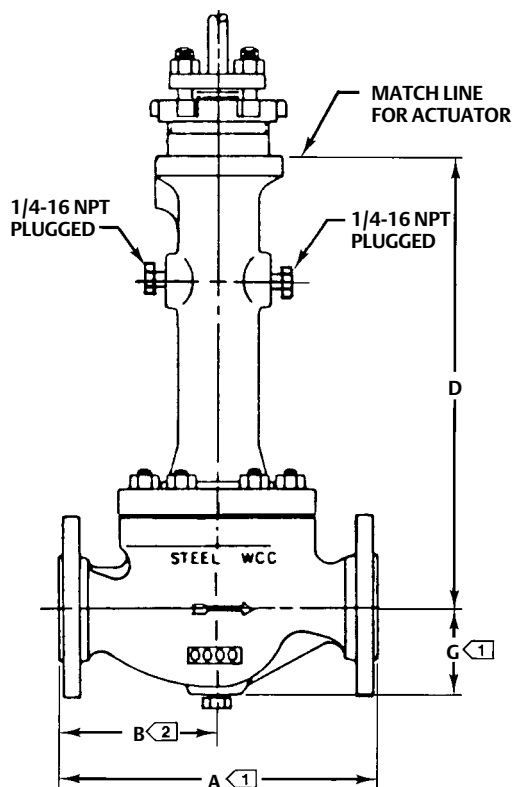

1287185-A
A6115-1

Notes:

- 1 For A and G dimensions, see figure 6.
- 2 B=A/2.

Table 18. ENVIRO-SEAL Bellows Seal Bonnet Dimensions

VALVE SIZE, NPS	D					
	ENVIRO-SEAL Bellows Seal Bonnet					
	Stem Diameter, mm			Stem Diameter, Inches		
	9.5	12.7	19.0	3/8	1/2	3/4
1	321	---	---	12.62	---	---
1-1/2	317	---	---	12.50	---	---
2	---	384	---	---	15.12	---
3	---	518	518	---	20.38	20.38
4	---	541	---	---	21.31	---

Ordering Information

Inlet pressure and temperature must always be limited by the applicable ASME pressure/temperature rating. Pressure drop information for various trim material combinations is provided in tables 10 and 11. Pressure drop information for gasket materials is listed in tables 12 and 13. The maximum allowable pressure drop for the application must not exceed the lowest value indicated for the combination of materials selected.

Table 19. Standard Dimensions

VALVE SIZE, NPS	D								
	Plain Bonnet			Extension Bonnet					
				Style 1			Style 2		
	Stem Diameter, mm								
	9.5	12.7	19.0	9.5	12.7	19.0	9.5	12.7	19.0
1/2 or 3/4	127	149	---	213	251	---	303	319	---
1	127	149	---	213	251	---	303	319	---
1-1/2	124	146	---	210	248	---	300	316	---
2	---	165	162	---	267	272	---	465	---
3	---	191	187	---	292	297	---	495	487
4	---	221	217	---	322	327	---	526	518
	Stem Diameter, Inches								
	3/8	1/2	3/4	3/8	1/2	3/4	3/8	1/2	3/4
1/2 or 3/4	5.00	5.88	---	8.38	9.88	---	11.94	12.56	---
1	5.00	5.88	---	8.38	9.88	---	11.94	12.56	---
1-1/2	4.88	5.75	---	8.25	9.75	---	11.81	12.44	---
2	---	6.50	6.38	---	10.50	10.69	---	18.31	---
3	---	7.50	7.38	---	11.50	11.69	---	19.50	19.19
4	---	8.69	8.56	---	12.69	12.88	---	20.69	21.38

Table 20. Standard Dimensions

VALVE SIZE, NPS	A									G (MAX)
	Scrd or SWE	CL125 FF or CL150 RF	CL150 RTJ	CL250 RF or CL300 RF	CL300 RTJ	BW or CL600 RF	CL600 RTJ	PN16-40 ⁽¹⁾	PN63-100 ⁽¹⁾	
	mm									
1/2 or 3/4	165	---	---	---	---	---	---	---	---	55
1	210	184	197	197	210	210	210	160	230	60
1-1/2	251	222	235	235	248	251	251	200	260	71
2	286	254	267	267	282	286	289	230	300	78
3	---	298	311	317	333	337	340	310	380	97
4	---	353	365	368	384	394	397	350	430	129
	Inches									
1/2 or 3/4	6.50	---	---	---	---	---	---	See mm	See mm	2.12
1	8.25	7.25	7.75	7.75	8.25	8.25	8.25			2.38
1-1/2	9.88	8.75	9.25	9.25	9.75	9.88	9.88			2.81
2	11.25	10.00	10.50	10.50	11.12	11.25	11.38			3.06
3	---	11.75	12.25	12.50	13.12	13.25	13.38			3.81
4	---	13.88	14.38	14.50	15.12	15.50	15.62			5.06

1. Valves which meet EN flange standards and have DN face-to-face dimensions are available only from Europe. Valves which meet EN flange standards but not DN face-to-face standards are available in the US. Consult your Emerson Automation Solutions sales office.

Figure 6. Standard Dimensions (also see tables 19 and 20)

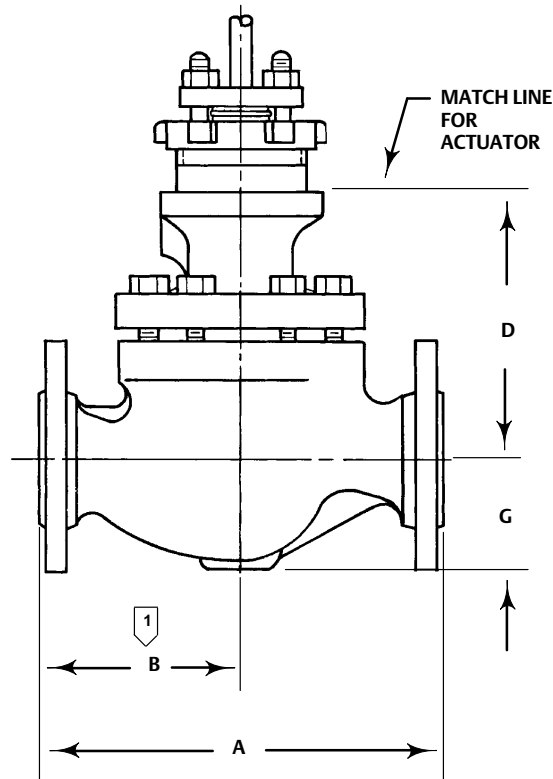

AR4967-A
A0925-2

EZ VALVE BODY

Notes:

1 $B = \frac{A}{2}$

Neither Emerson, Emerson Automation Solutions, nor any of their affiliated entities assumes responsibility for the selection, use or maintenance of any product. Responsibility for proper selection, use, and maintenance of any product remains solely with the purchaser and end user.

Fisher, easy-e, and ENVIRO-SEAL are marks owned by one of the companies in the Emerson Automation Solutions business unit of Emerson Electric Co. Emerson Automation Solutions, Emerson, and the Emerson logo are trademarks and service marks of Emerson Electric Co. All other marks are the property of their respective owners.

The contents of this publication are presented for informational purposes only, and while every effort has been made to ensure their accuracy, they are not to be construed as warranties or guarantees, express or implied, regarding the products or services described herein or their use or applicability. All sales are governed by our terms and conditions, which are available upon request. We reserve the right to modify or improve the designs or specifications of such products at any time without notice.

Emerson Automation Solutions
Marshalltown, Iowa 50158 USA
Sorocaba, 18087 Brazil
Cernay, 68700 France
Dubai, United Arab Emirates
Singapore 128461 Singapore

www.Fisher.com

