

Use these instructions to mount a FIELDVUE™ DVC6200/DVC2000 to a Linear Actuator.

## **⚠ WARNING**

**Avoid personal injury or property damage from sudden release of process pressure or bursting of parts. Before performing any maintenance operations:**

- Always wear protective clothing, gloves, and eyewear.
- Do not remove the actuator from the valve while the valve is still pressurized.
- Disconnect any operating lines providing air pressure, electric power, or a control signal to the actuator. Be sure the actuator cannot suddenly open or close the valve.
- Use bypass valves or completely shut off the process to isolate the valve from process pressure. Relieve process pressure from both sides of the valve.
- Vent the pneumatic actuator loading pressure and relieve any actuator spring precompression.
- Use lock-out procedures to be sure that the above measures stay in effect while you work on the equipment.
- Check with your process or safety engineer for any additional measures that must be taken to protect against process media.

The visual aids in this document are for general reference representation only. Refer to the appropriate actuator instruction manual for actuator installation, operation, maintenance, and parts identification as this manual **may or may not include all components shown for kit installation.**

1. Isolate the control valve from the process line pressure and release pressure from both sides of the valve body. Shut off all pressure lines to the actuator, releasing all pressure from the actuator. Use lock-out procedures to be sure that the above measures stay in effect while you work on the equipment.
2. Attach connector arm assembly to stem block using provided fasteners (including spacers and stud bolts, if applicable).

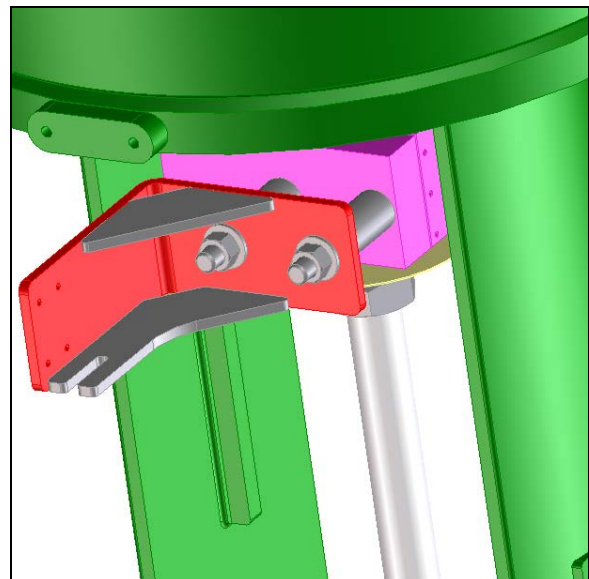
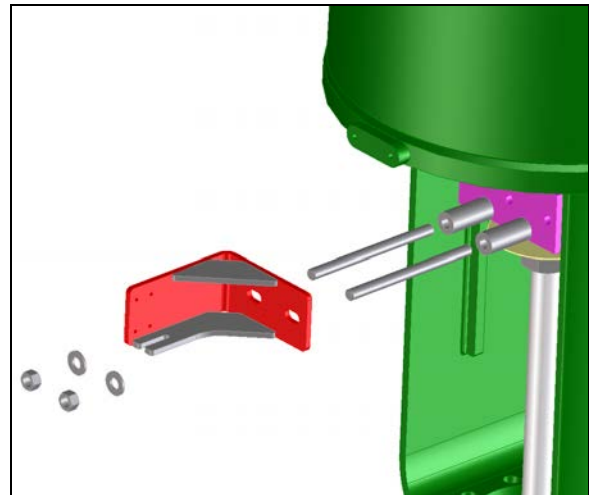

For fork-style connector arms remove the nuts and indicator disk from the stem. Place the fork-style extension arm flush with the bottom of the stem block onto the stem. Reattach the indicator disk and nuts.

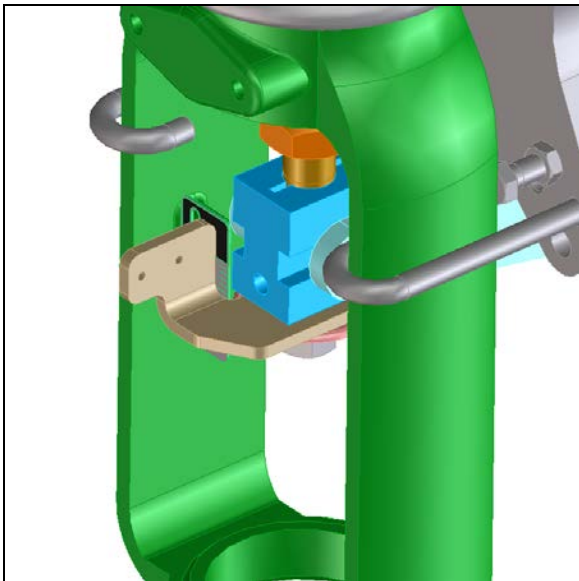
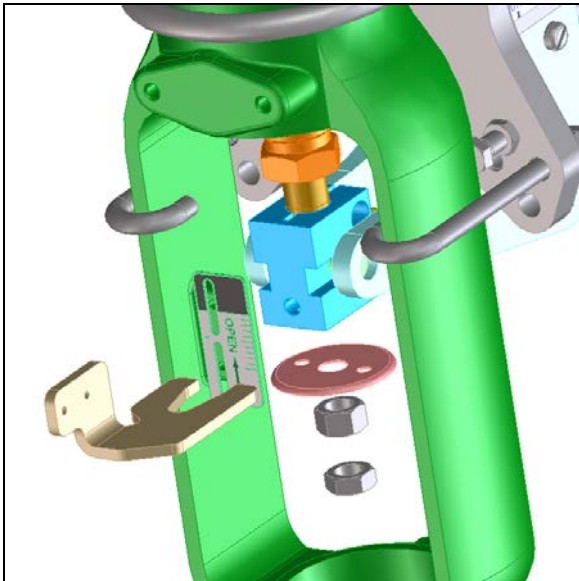

3. Loosely attach array to extension arm using provided fasteners. (Array not included with kit)

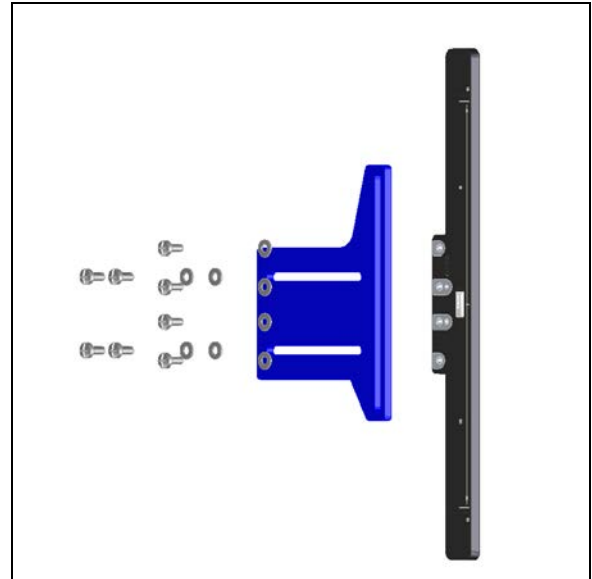

4. Attach extension arm with array assembly to connector arm.

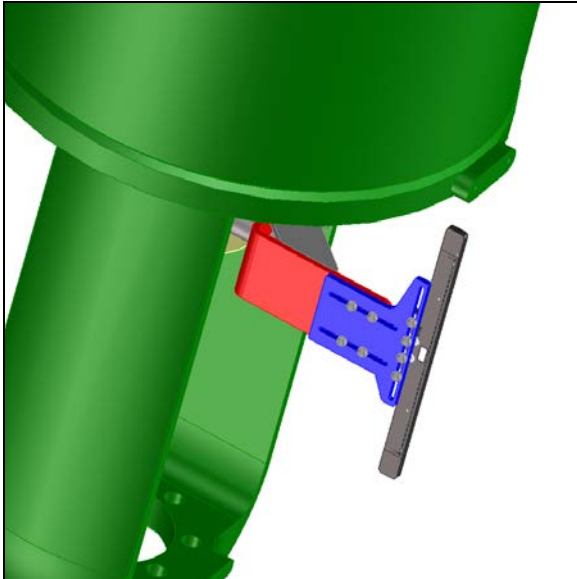

5. Attach mounting plate to actuator using provided hardware (including stud bolts, spacers, and L-brackets, if applicable).

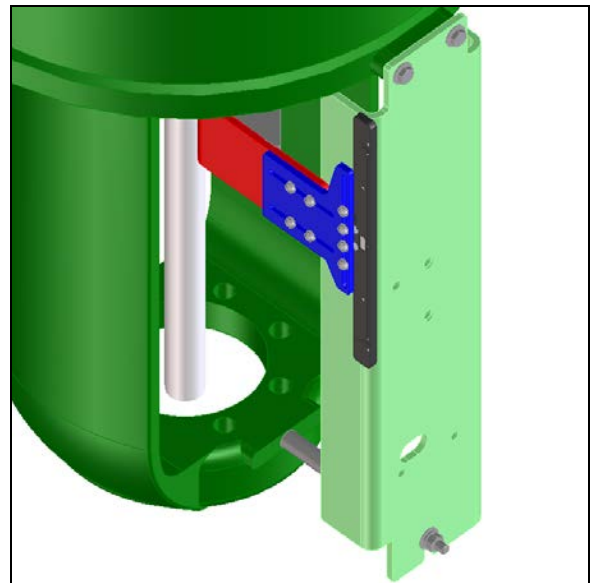
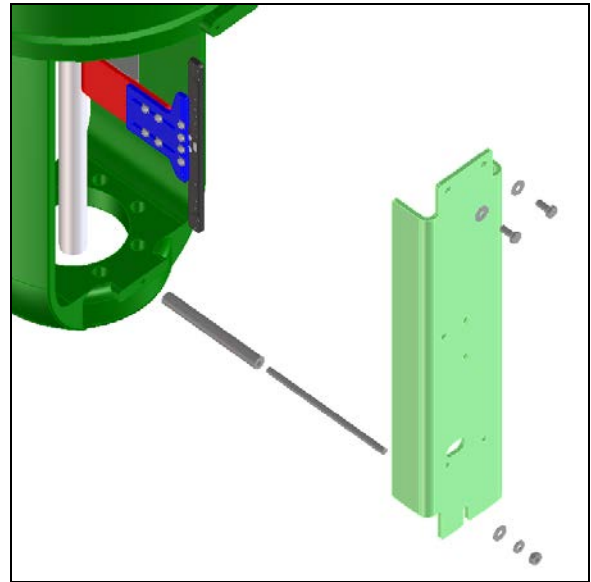

6. Attach aligning template to mounting plate. Adjust height of array until the middle line of the aligning template is level with the corresponding line of the array relative to stem block position. **\*\*\*Care needs to be taken to ensure that line the index marks on the array do not move outside of the center index mark on the alignment template\*\*\***

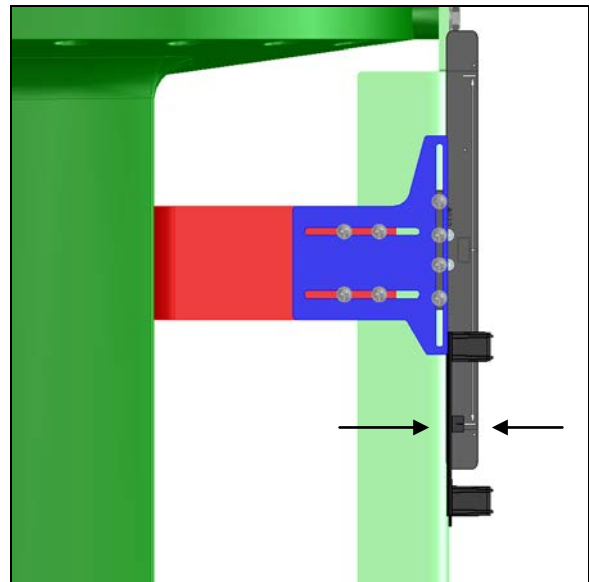
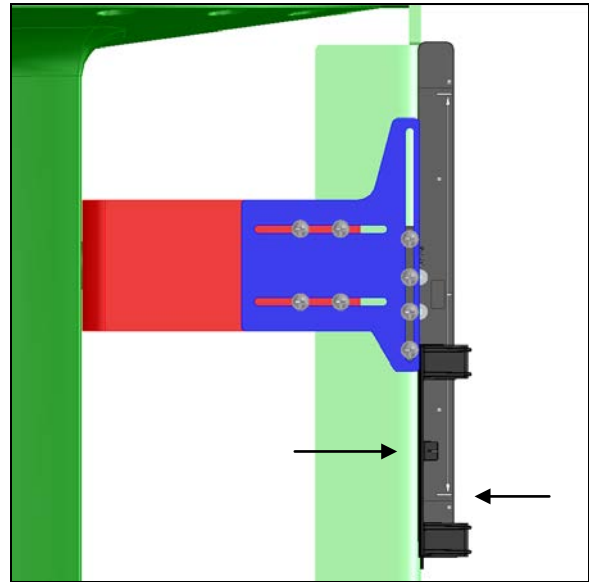
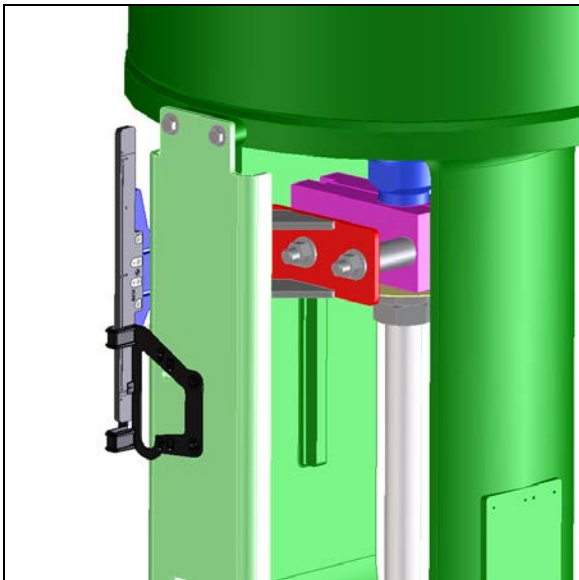
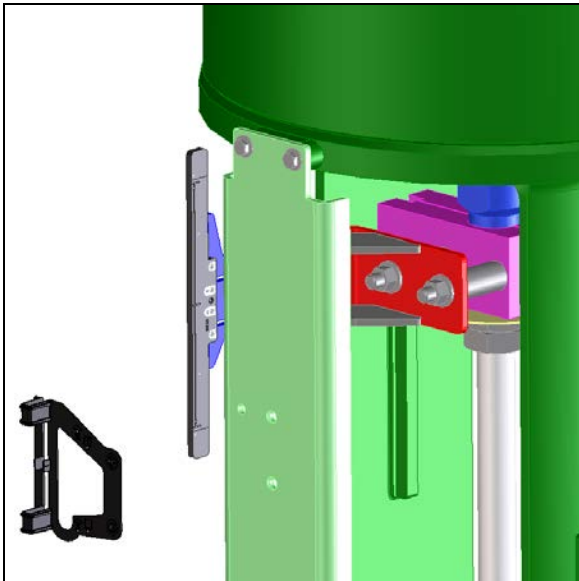

7. Attach insert assembly into the magnet housing slot on the back of the device using the provided 3m adhesive strip.

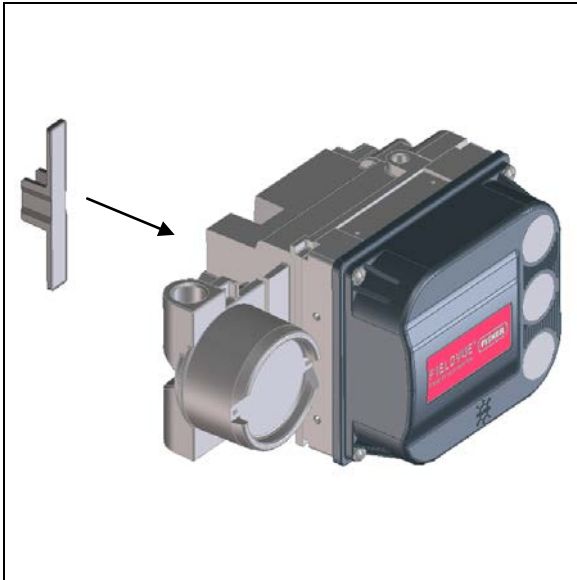

8. Remove aligning template. Attach device to mounting bracket using provided fasteners.

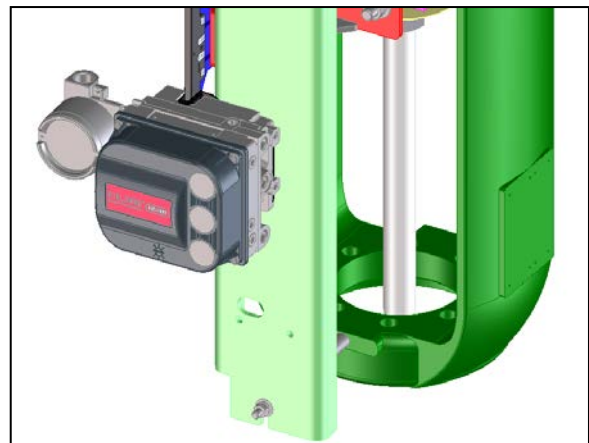
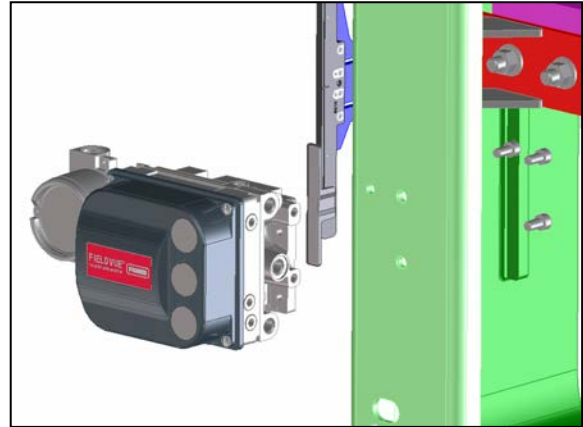

9. Attach remote mount air filter regulator (if applicable).

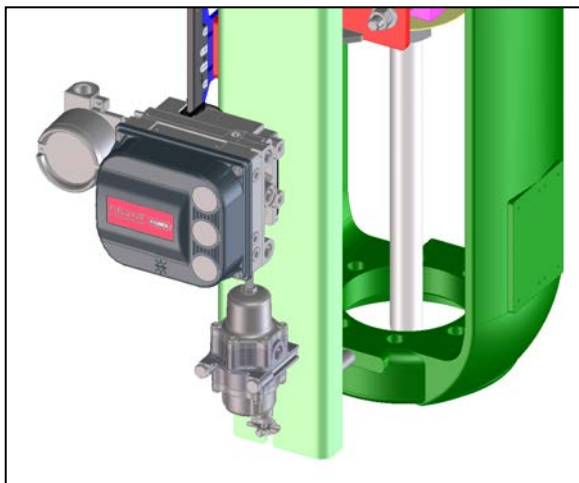
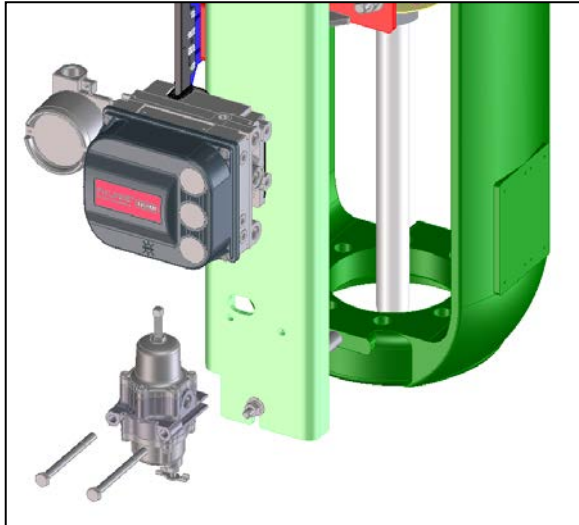

Final Assembly



Air Filter Regulator



DVC6200



Shield



Alignment Template

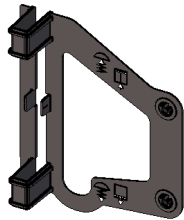

Extension Arm



Spacer



Connector Arm



Insert Assembly



U-Bracket



Common Mounting Bracket



Linear Feedback Array



DVC2000



Mounting Plate



**Neither Emerson, Emerson Process Management, Fisher, nor any of their affiliated entities assumes responsibility for the selection, use and maintenance of any product. Responsibility for the selection, use and maintenance of any product remains with the purchaser and end user.**

Fisher and FIELDVUE are marks owned by Fisher Controls International LLC, a member of the Emerson Process Management business unit of Emerson Electric Co. Emerson Process Management, Emerson, and the Emerson logo are trademarks and service marks of Emerson Electric Co. All other marks are the property of their respective owners.

The contents of this publication are presented for informational purposes only, and while every effort has been made to ensure their accuracy, they are not to be construed as warranties or guarantees, express or implied, regarding the products or services described herein or their use or applicability. We reserve the right to modify or improve the designs or specifications of such products at any time without notice.

**Emerson Process Management**

Marshalltown, Iowa 50158 USA  
Sorocaba, 18087 Brazil  
Chatham, Kent ME4 4QZ UK  
Dubai, United Arab Emirates  
Singapore 128461 Singapore