

# 289 Series Spring-Loaded Relief Valves Special Service Addendum for Propane Service

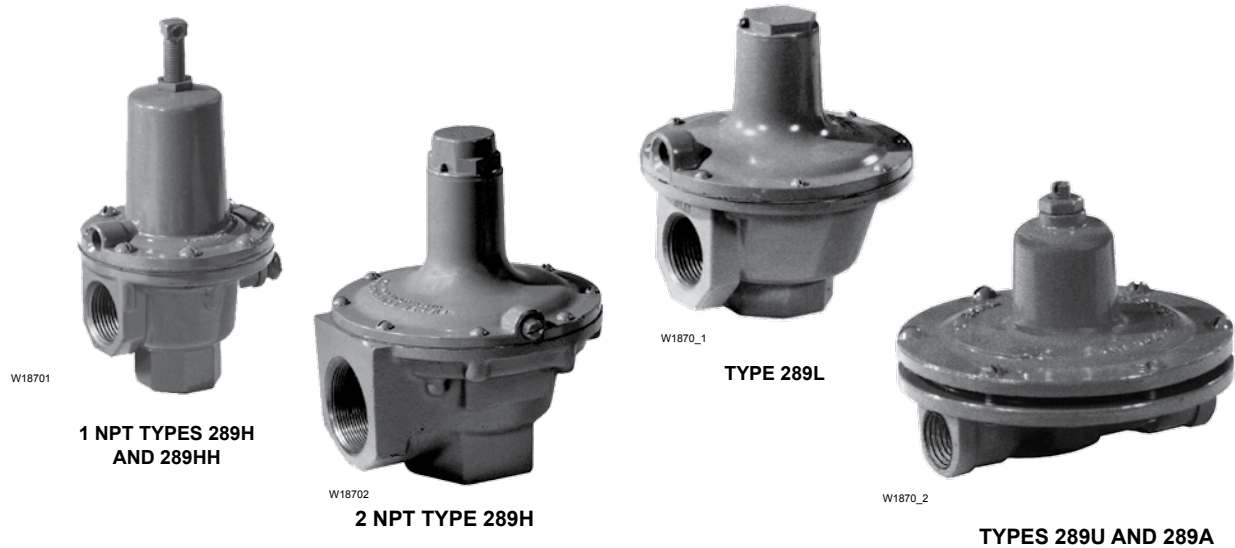

Figure 1. Types 289H, 289L, and 289U Relief Valves

## Introduction

The 289 Series relief valve is a throttling relief valve used downstream of pressure regulators to protect the downstream system from overpressure. A smooth throttling action minimizes pressure surges in the system during emergency operation. These relief valves are available in 1/4, 3/4, 1, or 2 NPT sizes with spring ranges (relief pressure settings) from 5-inches w.c. to 75 psig / 12 mbar to 5.2 bar.

All sizes above 1/4 NPT feature a pitot tube booster (Figure 1) for achieving the highest possible relief capacity with a minimum buildup of system pressure. When the valve is opening, high gas velocity through the orifice creates an area of relatively low pressure near the end of the pitot tube. This pitot tube effect forms a partial vacuum above the diaphragm which helps to open the valve.

The relief valve diaphragm functions as a valve disk to control flow in all types except the Types 289H and 289HH, which use O-ring seats. The Nitrile (NBR) or Neoprene (CR) seating surfaces provide tight

shutoff. The 289 Series relief valves are ideal for low-pressure settings due to the increased sensitivity provided by the large diaphragm area.

## Features

- **Throttling Type Relief**—Smooth, sensitive throttling action minimizes pressure surges.
- **High Flow Rates**—As shown by the Figure 3 capacity curves, high flow rates can be achieved with minimum pressure buildup due to the boosting system which increases the relief valve opening.
- **Small Size**—The 289 Series relief valves are small and compact, making them suitable for areas limited in space.
- **Reliability Due to Simplicity**—A single internal assembly decreases the possibility of mechanical failure.

## Specifications

### Available Configurations

**Type 289A:** 1/4 NPT spring-loaded relief valve for relief pressure settings of 3 to 22 psig / 0.21 to 1.5 bar, two spring ranges

**Type 289H:** 1 or 2 NPT spring-loaded relief valve for relief pressure settings of 1 to 50 psig / 0.07 to 3.4 bar four spring ranges, in the 1 NPT and of 7-inches w.c. to 10 psig / 17 mbar to 0.69 bar, four spring ranges, in the 2 NPT

**Type 289HH:** 1 NPT spring-loaded relief valve for relief pressure settings of 45 to 75 psig / 3.1 to 5.2 bar

**Type 289L:** 3/4 or 1 NPT spring-loaded relief valve for relief pressure settings of 10 to 40-inches w.c. / 25 to 99 mbar, two spring ranges

**Type 289U:** 1/4 NPT spring-loaded relief valve for relief pressure settings of 5-inches w.c. to 3 psig / 12 mbar to 0.21 bar, two spring ranges

### Inlet Connections

**Type 289L:** 3/4 or 1 NPT

**Types 289A and 289U:** 1/4 NPT

**Type 289H:** 1 or 2 NPT

**Type 289HH:** 1 NPT

### Outlet (Vent) Connections

Same size as inlet connection

### Maximum Allowable Relief (Inlet) Pressure<sup>(1)</sup> and Maximum Relief Set Pressure

See Table 1

### Capacity Data

See Figure 3

### Standard Construction Materials

#### Valve Body and Spring Case

*Types 289A and 289U:* Zinc

*Types 289H (1 NPT), 289HH, and 289L:* Aluminum

*Type 289H (2 NPT):* Cast iron body with Aluminum spring case

#### Diaphragm

*Type 289A:* Neoprene (CR)

*Types 289H and 289HH:* Nitrile (NBR) or Fluorocarbon (FKM)

*Types 289L and 289U:* Nitrile (NBR)

### Standard Construction Materials (continued)

#### Orifice

*Types 289A and 289L:* Aluminum

*Type 289H (2 NPT Only):* Brass or Stainless steel

#### O-ring Seat (Types 289H and 289HH Only):

Nitrile (NBR) or Fluorocarbon (FKM)<sup>(2)</sup>

#### O-ring Seat Holder and Washer

#### (1 NPT Types 289H and 289HH Only):

Aluminum

#### Seat Washer (2 NPT Type 289H Only):

Stainless steel

#### Pitot Tube

*Types 289H, 289HH (1 NPT), and 289L:*

Aluminum *Type 289H (2 NPT):* Brass or Stainless steel

#### Gaskets

*Type 289L:* Neoprene (CR)

*All Others:* Composition

#### Spring: Zinc-plated steel

#### Diaphragm Plate

*Types 289A and 289U:* Zinc

*All Others:* Zinc-plated steel

#### Closing Cap

*Type 289L:* Plastic, Aluminum, or Zinc

*Type 289H (2 NPT):* Zinc

### Temperature Capabilities<sup>(1)</sup>

#### With Nitrile (NBR) and Neoprene (CR) Elastomer:

-20 to 150°F / -29 to 66°C

#### With Fluorocarbon (FKM):

20 to 300°F / -7 to 149°C

Available with Types 289H and 289HH only

### Approximate Weights

**Types 289A and 289U:** 0.75 pounds / 0.3 kg

#### Type 289H

*1 NPT:* 4 pounds / 2 kg

*2 NPT:* 15 pounds / 7 kg

**Type 289HH:** 4 pounds / 2 kg

**Type 289L:** 15 pounds / 7 kg

### Options

- Polytetrafluoroethylene (PTFE) diaphragm protector (Types 289A and 289U only)
- Wire-seal on closing cap (1 NPT Type 289L only)

1. The pressure/temperature limits in this Bulletin and any applicable standard limitation should not be exceeded.

2. Bubble-tight shutoff cannot be attained at settings below 5 psig / 0.34 bar with Fluorocarbon (FKM) O-ring seat.

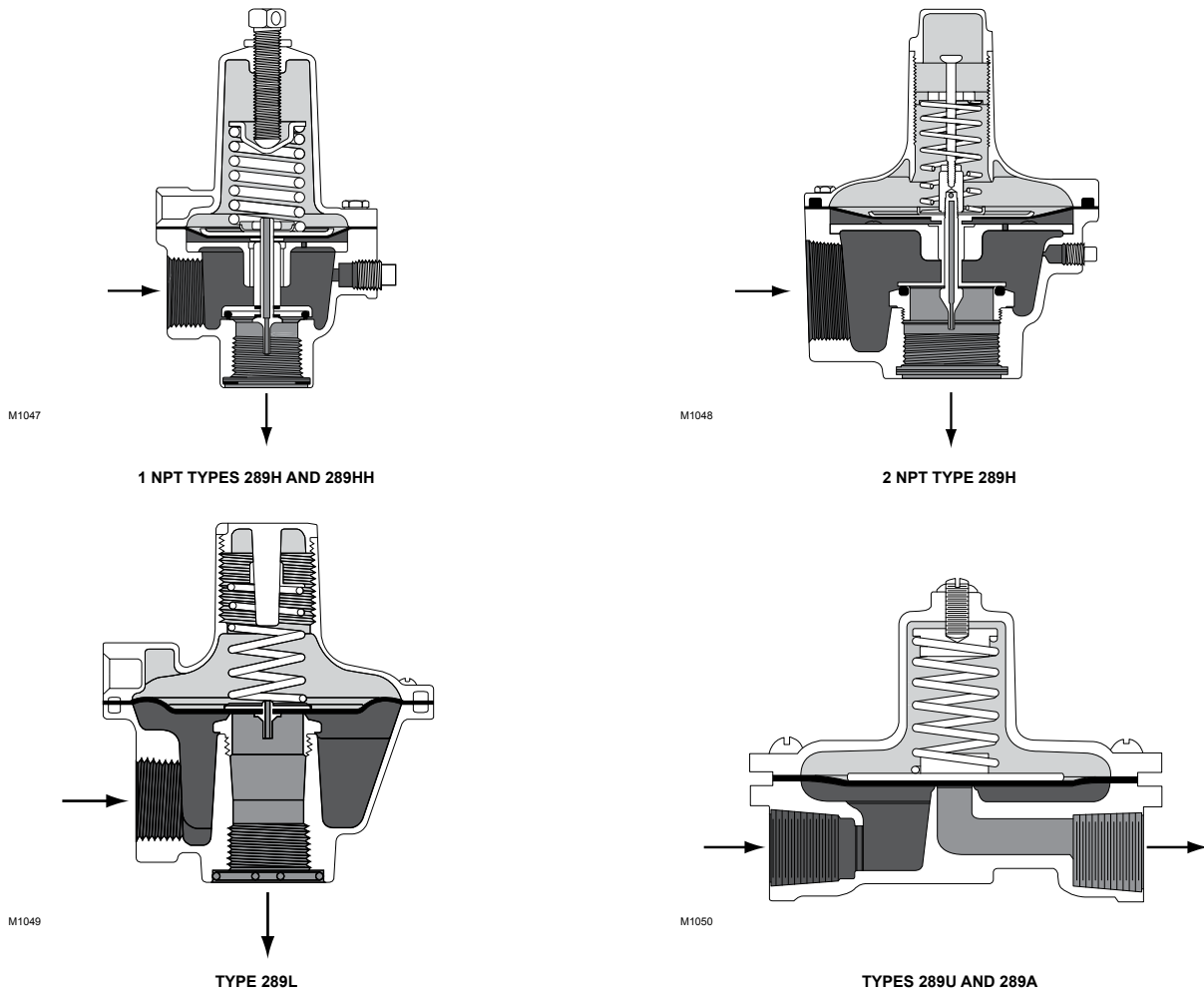

INLET PRESSURE  
 OUTLET PRESSURE  
 ATMOSPHERIC PRESSURE

**Figure 2.** Types 289H, 289L, and 289U Operational Schematics

**Table 1.** Maximum Allowable Relief (Inlet) Pressure

AVAILABLE CONFIGURATION	BODY SIZE, NPT	SPRING PART NUMBER	COLOR CODE	SPRING RANGE (RELIEF PRESSURE SETTINGS)		MAXIMUM ALLOWABLE RELIEF (INLET) PRESSURE <sup>(1)</sup>	
Type 289A	1/4	0Z056327022 1B268227022	Silver Silver	3 to 13 psig 11 to 22 psig	0.21 to 0.90 bar 0.76 to 1.5 bar	45 psig	3.1 bar
Type 289H	1	1F826927052 1D892327022 1D751527022 1D7455T0012	Pink	1 to 4.5 psig	0.07 to 0.31 bar	100 psig	6.9 bar
			Red	4 to 15 psig	0.28 to 1.0 bar		
			Silver	10 to 20 psig	0.69 to 1.4 bar		
			Green	15 to 50 psig	1.0 to 3.4 bar		
Type 289HH	2	1B536527052 1B536627052 1B536827062 1B536927052	Dark Blue	7 to 18-inches w.c.	17 to 45 mbar	25 psig	1.7 bar
			Gray	0.5 to 2.25 psig	0.03 to 0.16 bar		
			Dark Green	1.75 to 7 psig	0.12 to 0.48 bar		
			Red Stripe	4 to 10 psig	0.28 to 0.69 bar		
Type 289HH	1	1D7455T0012	Green	45 to 75 psig	3.1 to 5.2 bar	100 psig	6.9 bar
Type 289L	3/4 or 1	13A7917X012 13A7916X012	Silver Red Stripe	10 to 18-inches w.c. 12 to 40-inches w.c.	25 to 45 mbar 30 to 99 mbar	7 psig	0.48 bar
Type 289U	1/4	0V060227022 0F058227022	Silver Silver	5 to 25-inches w.c. 20-inches w.c. to 3 psig	12 to 62 mbar 50 to 207 mbar	10 psig	0.69 bar

1. This value indicates the relief pressure setting plus pressure build-up.

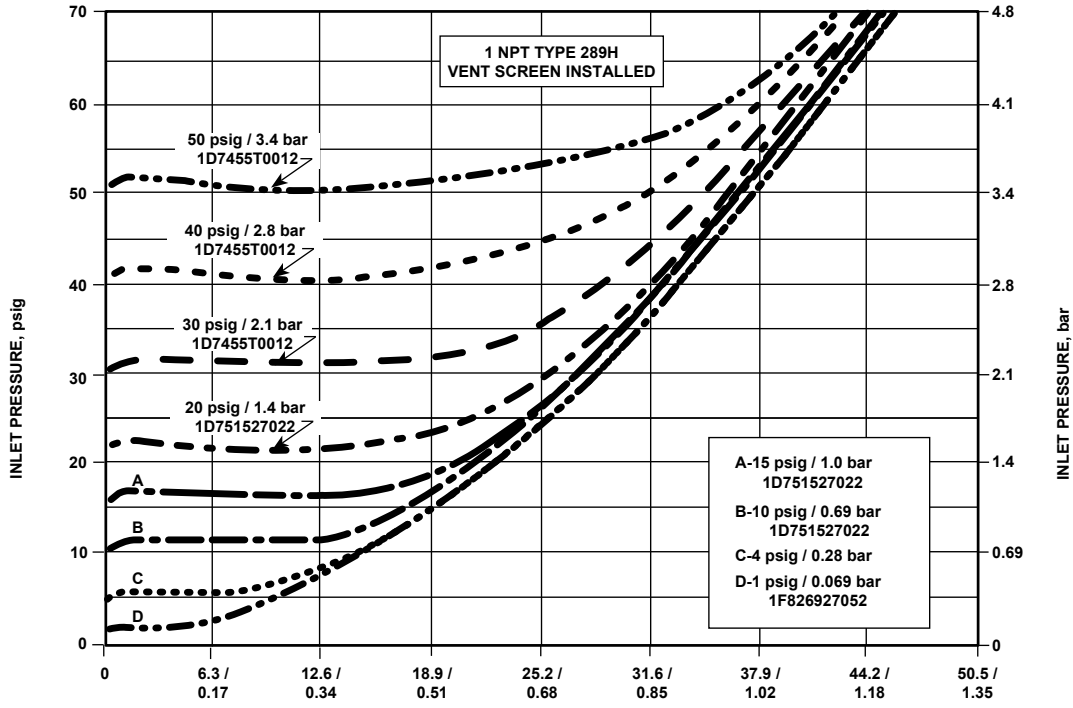

CAPACITIES IN THOUSANDS OF SCFH / Nm<sup>3</sup>/h OF 1.56 SPECIFIC GRAVITY PROPANE GAS AT 14.7 psia AT 60°F / 1.01325 bar AT 0°C

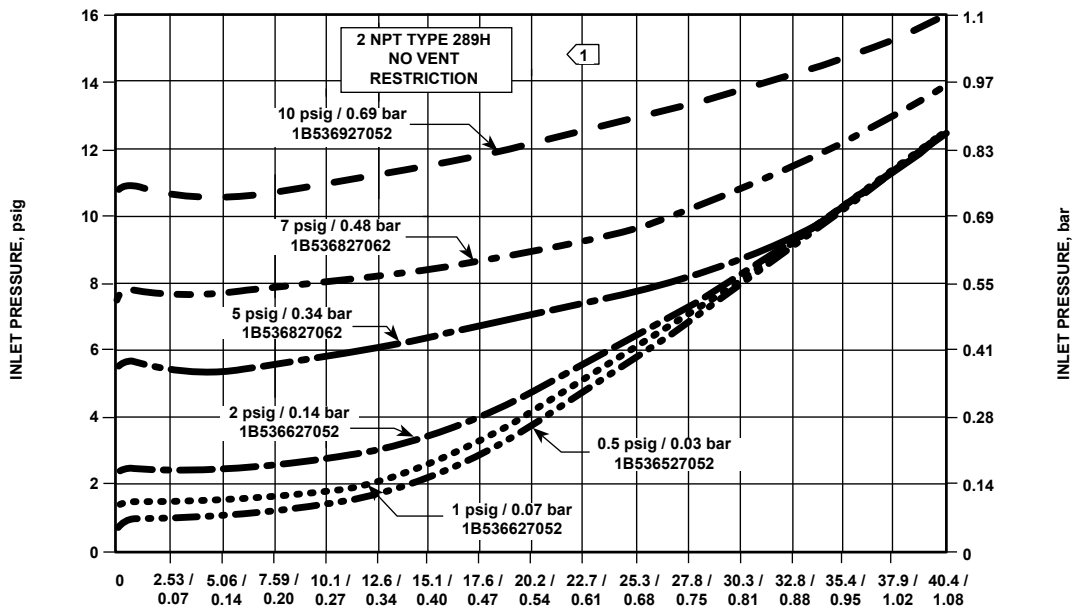

CAPACITIES IN THOUSANDS OF SCFH / Nm<sup>3</sup>/h OF 1.56 SPECIFIC GRAVITY PROPANE GAS AT 14.7 psia AT 60°F / 1.01325 bar AT 0°C

**NOTE:**

1. LESS THAN A 5% CAPACITY LOSS CAN BE EXPECTED WITH THE VENT SCREEN INSTALLED ON THE 2 NPT TYPE 289H AT MAXIMUM FLOW.
2. WHEN SELECTING ANY RELIEF VALVE FOR INSTALLATION DOWNSTREAM OF THE REGULATOR, THE CAPACITY OF THE RELIEF VALVE SHOULD BE COMPARED WITH THE WIDE-OPEN CAPACITY OF THE REGULATOR.
3. BUBBLE POINT RELIEF SETTING AND SPRING PART NUMBER ARE NOTED ON EACH CURVE.
4. TO CONVERT TO EQUIVALENT CAPACITIES OF OTHER GASES, MULTIPLY VALUES OBTAINED FROM CURVE BY THE FOLLOWING FACTORS: AIR-1.23, NATURAL GAS-1.60, BUTANE-0.86, NITROGEN-1.22.

Figure 3. Capacity Curves

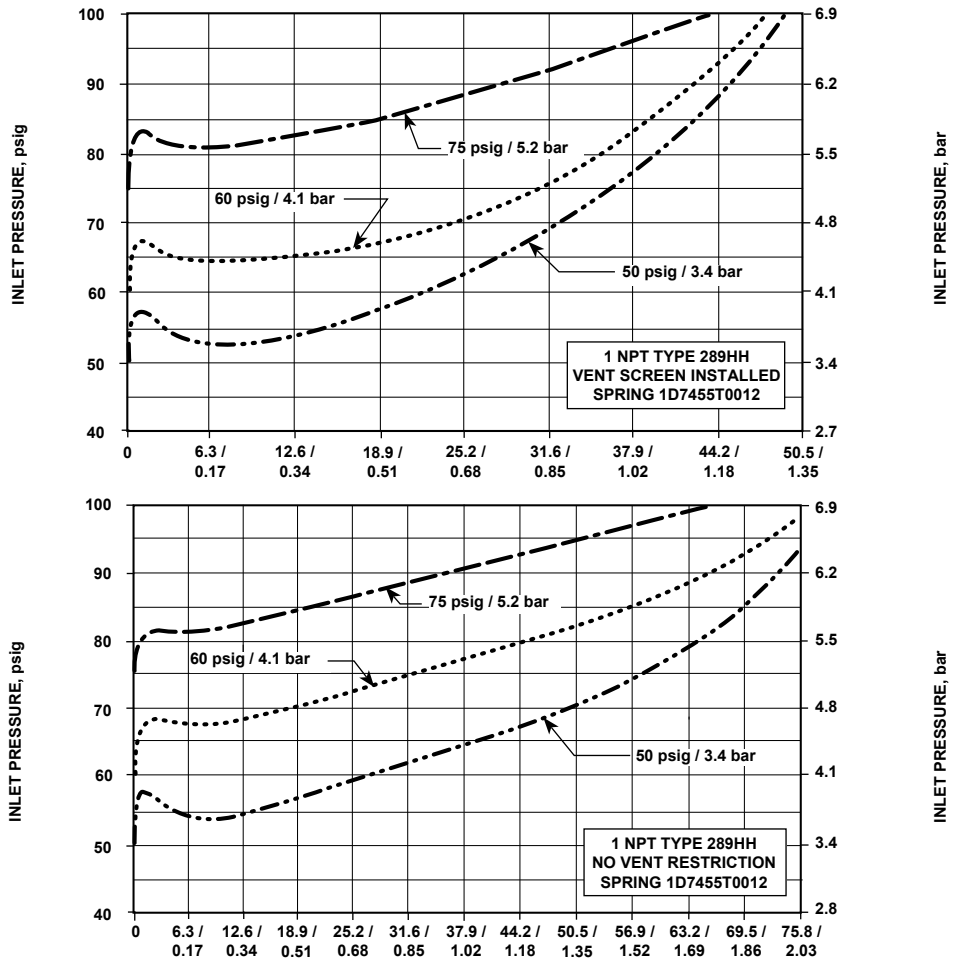

CAPACITIES IN THOUSANDS OF SCFH / Nm<sup>3</sup>/h OF 1.56 SPECIFIC GRAVITY PROPANE GAS AT 14.7 psia AT 60°F / 1.01325 bar AT 0°C

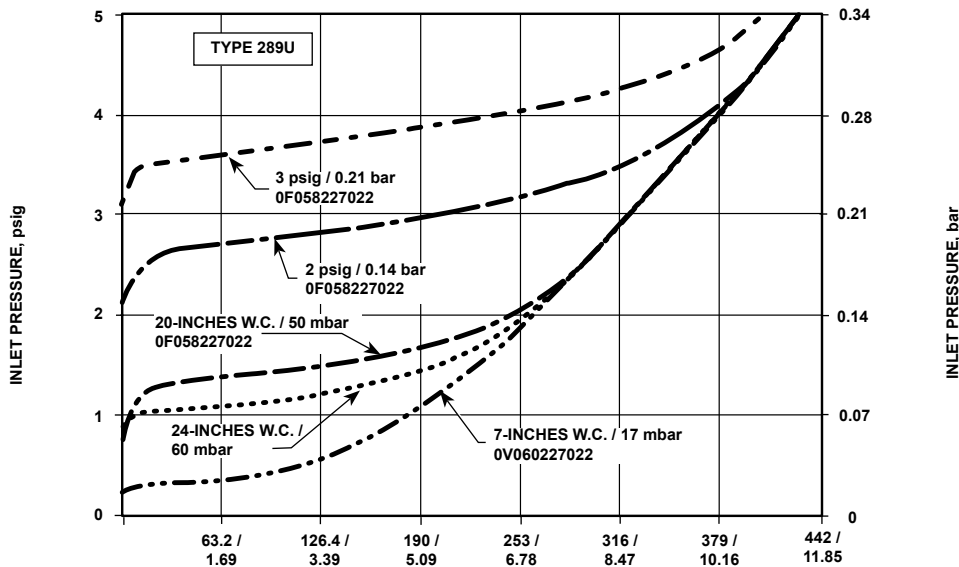

CAPACITIES IN SCFH / Nm<sup>3</sup>/h OF 1.56 SPECIFIC GRAVITY PROPANE AT 14.7 psia AT 60°F / 1.01325 bar AT 0°C

**NOTE:**

1. WHEN SELECTING ANY RELIEF VALVE FOR INSTALLATION DOWNSTREAM OF THE REGULATOR, THE CAPACITY OF THE RELIEF VALVE SHOULD BE COMPARED WITH THE WIDE-OPEN CAPACITY OF THE REGULATOR.
2. BUBBLE POINT RELIEF SETTING AND SPRING PART NUMBER ARE NOTED ON EACH CURVE.
3. TO CONVERT TO EQUIVALENT CAPACITIES OF OTHER GASES, MULTIPLY VALUES OBTAINED FROM CURVE BY THE FOLLOWING FACTORS: AIR-1.23, NATURAL GAS-1.60, BUTANE-0.86, NITROGEN-1.22.

Figure 3. Capacity Curves (continued)

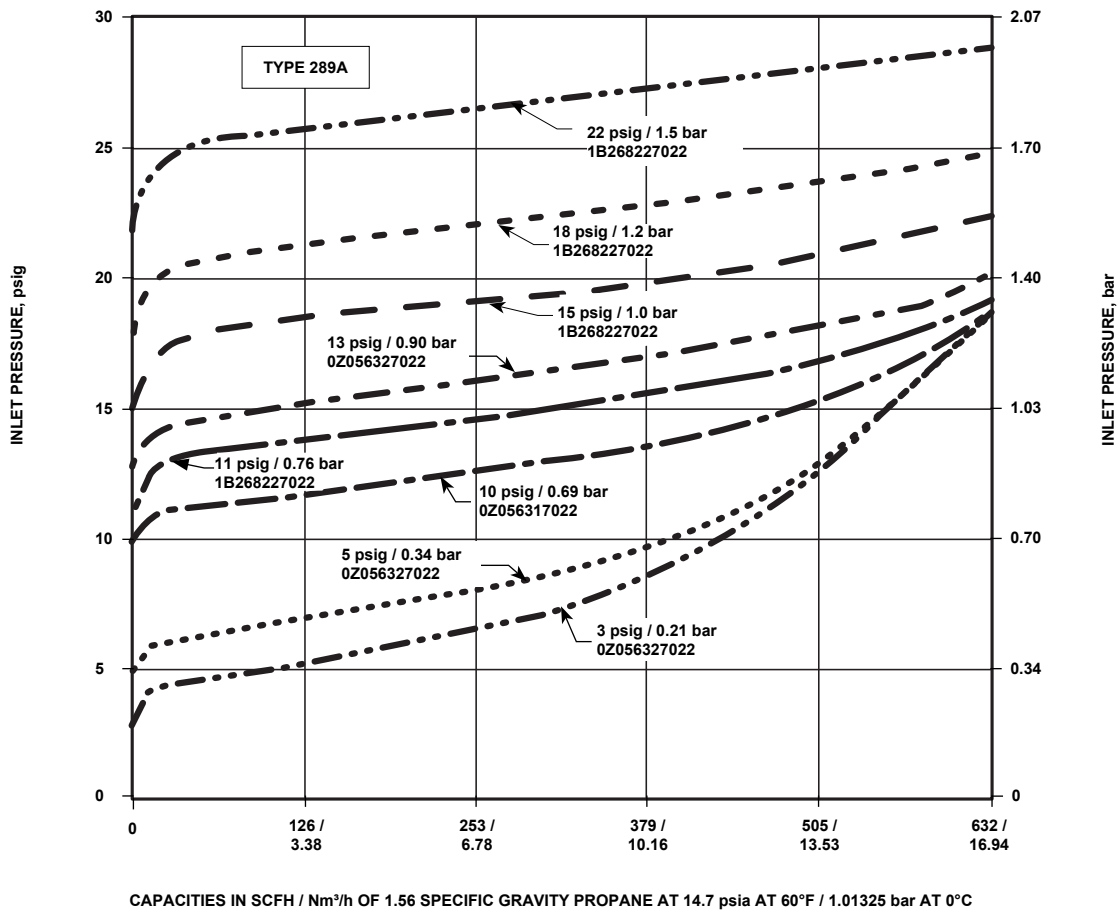
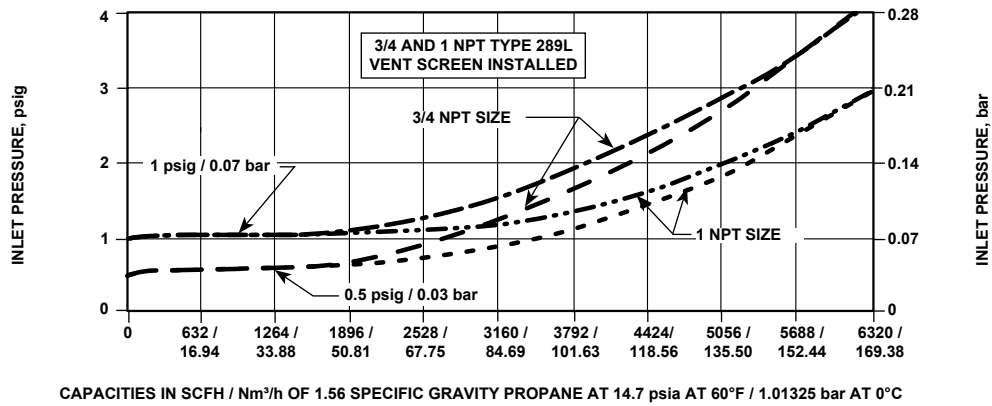

**NOTE:**

1. WHEN SELECTING ANY RELIEF VALVE FOR INSTALLATION DOWNSTREAM OF THE REGULATOR, THE CAPACITY OF THE RELIEF VALVE SHOULD BE COMPARED WITH THE WIDE-OPEN CAPACITY OF THE REGULATOR.
2. BUBBLE POINT RELIEF SETTING IS NOTED ON EACH CURVE.
3. TO CONVERT TO EQUIVALENT CAPACITIES OF OTHER GASES, MULTIPLY VALUES OBTAINED FROM CURVE BY THE FOLLOWING FACTORS: AIR-1.23, NATURAL GAS-1.60, BUTANE-0.86, NITROGEN-1.22.

Figure 3. Capacity Curves (continued)

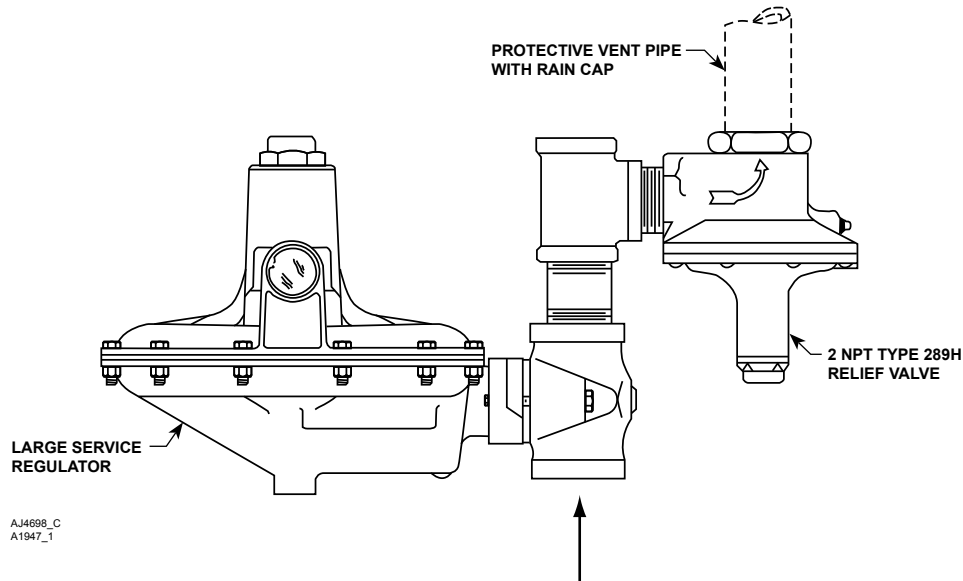

**Figure 4.** Typical Installation of a 289 Series Relief Valve

## Installation

The 289 Series relief valves may be installed in any position. However, the outlet connection must be protected against the entrance of rain, snow, insects, or any other foreign material that may plug the outlet or affect the opening and closing of the valve (see Figure 4). If it is necessary to pipe away the outlet, remove the outlet screen (if one is present).

Flow through the valve must be as indicated by the flow direction arrow on the body (inlet connection is marked on some sizes).

The spring case vent on the 2 NPT Type 289H is tapped and plugged. This vent opening must remain plugged to allow the pitot tube booster to function.

## Overpressure

Overpressure conditions in a regulating system may cause personal injury or equipment damage due to bursting of pressure-containing parts or explosion of accumulated gas. Check the system for damage if any of the maximum allowable relief (inlet) pressure ratings in Table 1 are exceeded.

## Ordering Information

When ordering, specify:

1. Type number and size
2. Relief pressure range and setting desired
3. Type of gas (propane gas, natural gas, air, etc.); list any factors such as impurities in the gas that may affect compatibility of the gas with valve trim parts
4. Temperature and specific gravity of the gas
5. Maximum relief (inlet) pressure and flow rate desired
6. Line size and end connection size of adjacent piping
7. For Types 289H and 289HH, specify material of diaphragm and O-ring seat; for 2 NPT Type 289H, specify material of orifice and pitot tube
8. Options desired, if any

# Bulletin LP-7:289

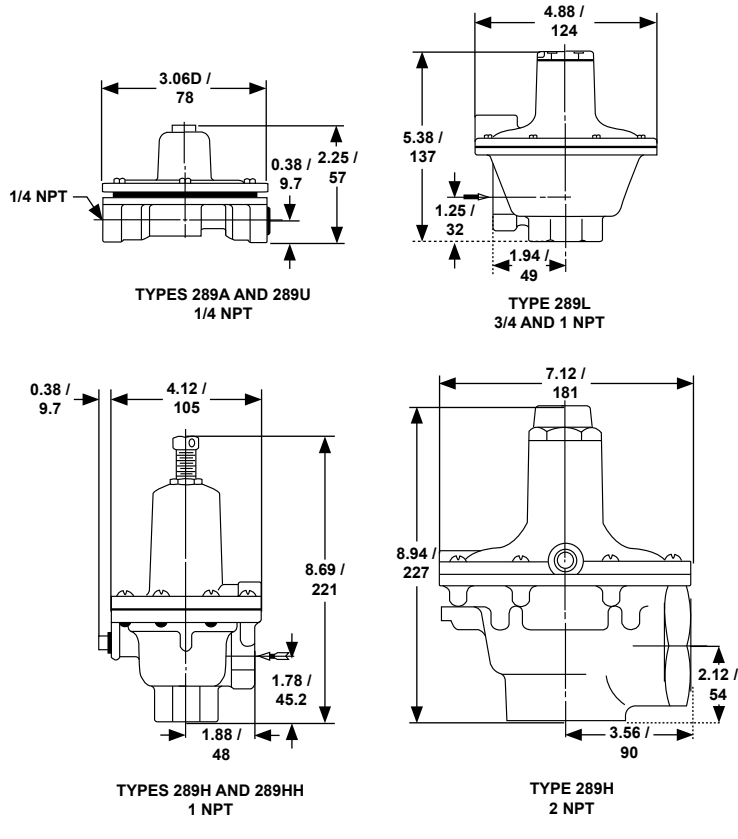

A1393\_2

**Figure 5. Dimensions**

## Industrial Regulators

### Emerson Process Management Regulator Technologies, Inc.

USA - Headquarters  
 McKinney, Texas 75070, USA  
 Tel: +1 800 558 5853  
 Outside U.S. +1 972 548 3574

Asia-Pacific  
 Shanghai 201206, China  
 Tel: +86 21 2892 9000

Europe  
 Bologna 40013, Italy  
 Tel: +39 051 419 0611

Middle East and Africa  
 Dubai, United Arab Emirates  
 Tel: +971 4811 8100

## Natural Gas Technologies

### Emerson Process Management Regulator Technologies, Inc.

USA - Headquarters  
 McKinney, Texas 75070, USA  
 Tel: +1 800 558 5853  
 Outside U.S. +1 972 548 3574

Asia-Pacific  
 Singapore 128461, Singapore  
 Tel: +65 6770 8337

Europe  
 Bologna 40013, Italy  
 Tel: +39 051 419 0611  
 Chartres 28008, France  
 Tel: +33 2 37 33 47 00

## TESCOM

### Emerson Process Management Tescom Corporation

USA - Headquarters  
 Elk River, Minnesota 55330-2445, USA  
 Tels: +1 763 241 3238  
 +1 800 447 1250

Europe  
 Selmsdorf 23923, Germany  
 Tel: +49 38823 31 287

Asia-Pacific  
 Shanghai 201206, China  
 Tel: +86 21 2892 9499

For further information visit [www.emersonprocess.com/regulators](http://www.emersonprocess.com/regulators)

The Emerson logo is a trademark and service mark of Emerson Electric Co. All other marks are the property of their prospective owners. Fisher is a mark owned by Fisher Controls International LLC, a business of Emerson Process Management.

The contents of this publication are presented for informational purposes only, and while every effort has been made to ensure their accuracy, they are not to be construed as warranties or guarantees, express or implied, regarding the products or services described herein or their use or applicability. We reserve the right to modify or improve the designs or specifications of such products at any time without notice.

Emerson Process Management does not assume responsibility for the selection, use or maintenance of any product. Responsibility for proper selection, use and maintenance of any Emerson Process Management product remains solely with the purchaser.