

Fisher® 461 Increased Outlet Angle Sweep-Flo Valve

The Fisher 461 Sweep-Flo valve is a self-cleaning, increased outlet, angle valve that is typically used in the chemical and hydrocarbon industries where control of residual oils or other liquids with coking properties is necessary. The 461 features a venturi-type throat, which is useful in power plants or slurry services where high pressure drops and flashing might exist. Typical trim materials include an S44004 stainless steel plug, an S31600 stainless steel with CoCr-A hardfaced seat ring, and a hardened 410/416 stainless steel liner.

For increased protection, the 461 valve is offered with tungsten carbide trim. Use this trim only in the most severe abrasive conditions or in moderately corrosive environments.

Tungsten carbide inserts are used for the plug tip, seat ring, and the seat ring retainer. Typically, S17400 stainless steel is used as the base material.



W9553-2

Fisher 461 Valve with 657 Actuator

Features

- **Flashing, Outgassing, and Cavitation Control**—Increased outlet size reduces outlet fluid velocity to reduce flashing, outgassing, and cavitation damage with proper trim material selection.
- **Flow Characteristic**—Special cylinder-guided contour valve plug furnishes an equal percentage Micro-Form flow characteristic in the 12.7 to 31.8 mm (0.5 to 1.25 inch) port size and a modified parabolic flow characteristic in the 38.1 to 114.3 mm (1.5 to 4.5 inch) port size.
- **Availability**—NPS 2x3, 3x4, 4x6, and 6x8 valves are available with either flanged or welding ends in ratings from CL150 to 1500. NPS 2x3, 3x4, and 4x6 valves are available with CL2500 rating.
- **Flushing Connection**—Connection on the side of the valve is furnished for flushing oil between liner and valve plug guide to prevent buildup of coke. An optional bonnet purge connection is also available with extension bonnet. See figure 1.
- **Extended Trim Life**—Tungsten carbide trim is available for the most severe conditions and may extend the life of your trim.
- **Excellent Sealing Capability**—ENVIRO-SEAL™ packing systems (figure 4) provide an improved stem seal to help prevent the loss of process fluid. These packing systems feature PTFE or Graphite ULF packing with live-loading for reduced packing maintenance.



Specifications

Available Valve Sizes

See table 1

End Connections

■ CL150 to CL2500 raised-face (RF), ■ ring type joint (RTJ) or buttweld end (BWE)

Maximum Inlet Pressures and Temperatures⁽¹⁾

Consistent with applicable pressure/temperature rating according to ASME B16.34 ratings unless limited by temperature capabilities (see table 2)

Shutoff Classifications per ANSI/FCI 70-2 and IEC 60534-4

■ Class IV (standard), ■ Class V (optional)

Construction Materials

See table 2

Temperature Capabilities

Valve Body/Trim Combinations: See table 2
All Other Parts: See table 3

Flow Coefficients

See table 1 and Fisher Catalog 12

Flow Characteristic

■ Equal percentage (NPS 1/2 to 1-1/4 port sizes)
■ Modified parabolic flow (NPS 1-1/2 to 4-1/2 port sizes)

Flow Direction

Flow down (pressure tends to close)

Port Diameters, Valve Plug Travels, and Stem Sizes

See table 1

Typical Bonnet Styles

■ Plain (standard)
■ Extension (high temperature applications)

1. The pressure/temperature limits in this bulletin and any applicable standard or code limitation for valve should not be exceeded.

Contents

Features	1
Specifications	2
Special Constructions Available	3
Actuator Combinations	3
Tables	
Maximum Trim Size and Flow Coefficients	3
Typical Trim Combinations	4

Construction Materials and	
Temperature Capabilities	4
CL300 and CL600 Dimensions	5
CL900 and CL1500 Dimensions	6
CL2500 Dimensions	6
Weights (includes valve body and bonnet)	7

Table 1. Maximum Trim Size and Flow Coefficients

VALVE SIZE, NPS	PORT DIAMETER		MAXIMUM PLUG TRAVEL		STEM SIZE		C _v AT MAXIMUM TRAVEL
	mm	Inches	mm	Inches	mm	Inches	
2x3	12.7	0.5	19	0.75	19	0.75	11.7
	19.1	0.75	19	0.75	19	0.75	25.4
	25.4	1	19	0.75	19	0.75	41.1
	31.8	1.25	29	1.125	19	0.75	74.9
	38.1	1.5	29	1.125	19	0.75	100
	41.3	1.625	29	1.125	19	0.75	106
3x4	25.4	1	19	0.75	19	0.75	45.2
	31.8	1.25	29	1.125	19	0.75	79.4
	38.1	1.5	29	1.125	19	0.75	104
	44.5	1.75	29	1.125	19	0.75	112
	50.8	2	29	1.125	19	0.75	122
	57.2	2.25	29	1.125	19	0.75	122
4x6	50.8	2	29	1.125	25.4	1	191
	57.2	2.25	29	1.125	25.4	1	217
	63.5	2.5	38	1.5	25.4	1	311
	69.9	2.75	38	1.5	25.4	1	331
	76.2	3	38	1.5	25.4	1	331
6x8	76.2	3	38	1.5	25.4	1	342
	88.9	3.5	51	2	25.4	1	475
	101.6	4	51	2	25.4	1	605
	114.3	4.5	51	2	25.4	1	764

Special Constructions Available

- Extension bonnet to reduce conduction of heat to packing and actuator.
- Pressure equalization piping from valve inlet to the area above the valve plug is available to flush coke out of the extension bonnet cavity and back into the flowstream as the valve plug opens.

- Valve outlet extension nozzle can be provided to further reduce cavitation and erosion damage in tank-mounted installations.

Actuator Combinations

The 461 valve can be combined with Fisher 657 direct-acting, 667 reverse-acting, or 585C piston actuators. See the appropriate actuator bulletin.

Table 2. Typical Trim Combinations⁽¹⁾

TRIM DESIGNATION	VALVE BODY MATERIAL	VALVE PLUG	SEAT RING	LINER (GUIDE CYLINDER)	RETAINER	TEMPERATURE CAPABILITIES			
						°C		°F	
						Min	Max	Min	Max
401	WCC WC9 SA-217-C5	S44004 HT	S31600/ CoCr-A	410/416 HT	410/416	-29	427	-20	800
402	WCC	S31600/ CoCr-A	S31600/ CoCr-A	S31600/ CoCr-A/ Chrome Coated	316/CoCr-A	-29	427	-20	800
403	CF8M CF8C	S31600/ CoCr-A	S31600/ CoCr-A	S31600/ CoCr-A/ Chrome Coated	316/CoCr-A	-198	593	-325	1100
404	WCC	17-4 SST/CoCr-A Tungsten Carbide	17-4 SST Tungsten Carbide	410/416 HT	17-4/ Tungsten Carbide	-29	427	-20	800
405	CF8M CF8C	N07718/CoCr-A Tungsten Carbide	N07718 Tungsten Carbide	S31600/ CoCr-A/ Chrome Coated	N07718/ Tungsten Carbide	-29	482	-20	900

1. Additional materials are available. Consult your local Emerson Process Management sales office for assistance.

Table 3. Construction Materials and Temperature Capabilities

PART	MATERIAL	TEMPERATURE CAPABILITIES				
		°C		°F		
		Minimum	Maximum	Minimum	Maximum	
Valve plug stem	S20910 (standard)	(1)	(1)	(1)	(1)	
	N07718 HT	(1)	(1)	(1)	(1)	
	S31600	(1)	417	(1)	800	
	Stud Nut Material	Body Material				
Valve Body-to-bonnet bolting	Studs Nuts SST GR 660 Studs Steel SA194-7 Nuts	CF8M	-29	538	-20	1000
	Studs Nuts Steel SA193-B7 Studs Steel SA194-2H Nuts	WCC, WC9, and SA-217-C5	-29	427	-20	800
		CF8M	-48	232	-55	450
Studs Nuts	SST SA479-XM-19 Studs Steel SA194-7 Nuts	CF8M and S31600	-46	593	-50	1100
Body to bonnet gasket	Metal jacketed gasket N04400	(1)	(1)	(1)	(1)	
Packing	PTFE V-ring	-40	232	-40	450	
	Graphite ribbon filament (oxidizing service to 371 °C [700 °F])	-73	538	-100	1000	
	Graphite ULF (non-environmental service)	-198	538	-325	1000	
Packing follower, spring, or lantern ring	S31600 stainless steel	-198	593	-325	1100	
Packing box ring	S31600 stainless steel	-198	593	-325	1100	
Packing flange, studs, or nuts	S31600 stainless steel	-198	593	-325	1100	

1. These materials are not limiting factors.

Figure 1. Dimensions (also see tables 4, 5, and 6)

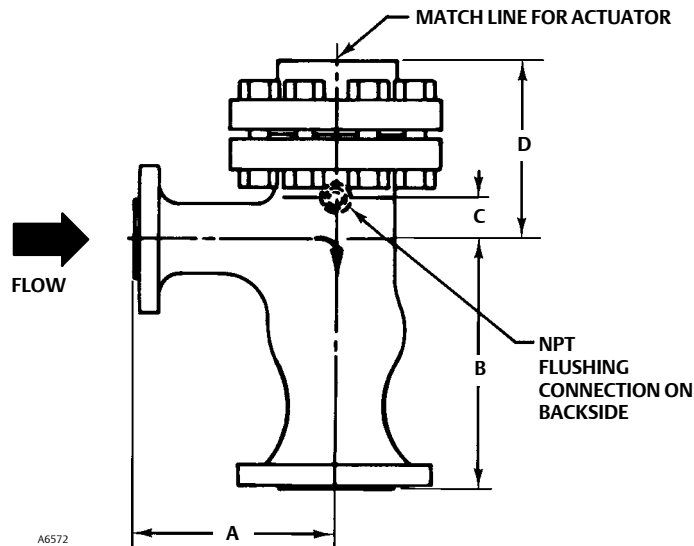

Table 4. CL300 and CL600 Dimensions

SIZE	NPT	A INLET FLANGE				B OUTLET FLANGE				D ⁽¹⁾ STANDARD BONNET		D ⁽¹⁾ RADIATION FIN BONNET		C
		300 RF	300 RTJ	600 RF	600 RTJ	300 RF	300 RTJ	600 RF	600 RTJ	Yoke Boss Size		Yoke Boss Size		
										3-9/16	5	3-9/16	5	
mm														
2 x 3	1/2-14	213	221	222	224	283	291	292	294	200	318	364	421	13
3 x 4	1/2-14	238	246	248	249	337	344	349	351	267	321	377	435	24
4 x 6	3/4-14	241	249	254	256	425	433	443	445	283	419	441	500	13
6 x 8	3/4-14	305	313	322	324	533	541	554	556	---	---	522	579	44
Inch														
2 x 3	1/2-14	8.38	8.69	8.75	8.81	11.13	11.44	11.50	11.56	7.88	12.50	14.32	16.56	0.50
3 x 4	1/2-14	9.38	9.69	9.75	9.81	13.25	13.56	13.75	13.81	10.51	12.63	14.83	17.13	0.94
4 x 6	3/4-14	9.50	9.81	10.00	10.06	16.75	17.06	17.44	17.50	11.13	16.49	17.38	19.69	0.50
6 x 8	3/4-14	12.00	12.31	12.69	12.75	21.00	21.31	21.81	21.88	---	---	20.56	22.81	1.75

1. This is the largest dimension that is provided.

Table 5. CL900 and CL1500 Dimensions

SIZE	NPT	A INLET FLANGE				B OUTLET FLANGE				D ⁽¹⁾ STANDARD BONNET		D ⁽¹⁾ RADIATION FIN BONNET		C
		900 RF	900 RTJ	1500 RF	1500 RTJ	900 RF	900 RTJ	1500 RF	1500 RTJ	Yoke Boss Size		Yoke Boss Size		
										3-9/16	5	3-9/16	5	
mm														
2 x 3	1/2-14	241	243	241	243	297	298	306	308	284	284	386	443	25
3 x 4	1/2-14	254	256	264	265	356	357	365	367	305	378	354	477	38
4 x 6	3/4-14	295	297	305	306	433	435	461	464	---	457	500	557	51
6 x 8	3/4-14	---	---	381	383	---	---	579	583	---	572	---	608	25
Inch														
2 x 3	1/2-14	9.50	9.56	9.50	9.56	11.69	11.75	12.06	12.13	11.19	11.18	15.19	17.44	1.00
3 x 4	1/2-14	10	10.06	10.38	10.44	14	14.06	14.38	14.44	12.00	14.88	13.94	18.76	1.50
4 x 6	3/4-14	11.63	11.69	12	12.06	17.06	17.13	18.13	18.25	---	18.00	19.69	21.94	2.00
6 x 8	3/4-14	---	---	15.00	15.06	---	---	22.81	22.94	---	22.50	---	23.94	1.00

1. This is the largest dimension that is provided.

Table 6. CL2500 Dimensions

SIZE	NPT	A INLET FLANGE		B OUTLET FLANGE		D ⁽¹⁾ STANDARD BONNET		D ⁽¹⁾ RADIATION FIN BONNET		C
		2500 RF	2500 RTJ	2500 RF	2500 RTJ	Yoke Boss Size		Yoke Boss Size		
						3-9/16	5	3-9/16	5	
mm										
2 x 3	1/2-14	260	262	327	330	276	419	443	502	32
3 x 4	1/2-14	327	330	367	372	414	437	530	584	32
4 x 6	3/4-14	375	379	461	467	---	468	---	---	51
Inch										
2 x 3	1/2-14	10.25	10.31	12.88	13	10.88	16.49	17.44	19.75	1.25
3 x 4	1/2-14	12.88	13	14.44	14.63	16.31	17.19	20.87	23.00	1.25
4 x 6	3/4-14	14.75	14.94	18.13	18.38	---	18.43	---	---	2.00

1. This is the largest dimension that is provided.

Table 7. Approximate Weights (includes valve body and bonnet)

VALVE SIZE, NPS	PRESSURE RATING	WEIGHT	
		kg	lb
2x3	CL300	100	219
	CL600	100	219
	CL900	120	265
	CL1500	136	300
	CL2500	168	370
3x4	CL300	130	286
	CL600	130	286
	CL900	152	335
	CL1500	169	371
	CL2500	286	630
4x6	CL300	218	480
	CL600	228	502
	CL900	405	890
	CL1500	448	985
	CL2500	673	1481
6x8	CL300	327	720
	CL600	382	841
	CL900	694	1526
	CL1500	776	1707

Figure 2. Fisher 461 Valve - Closed

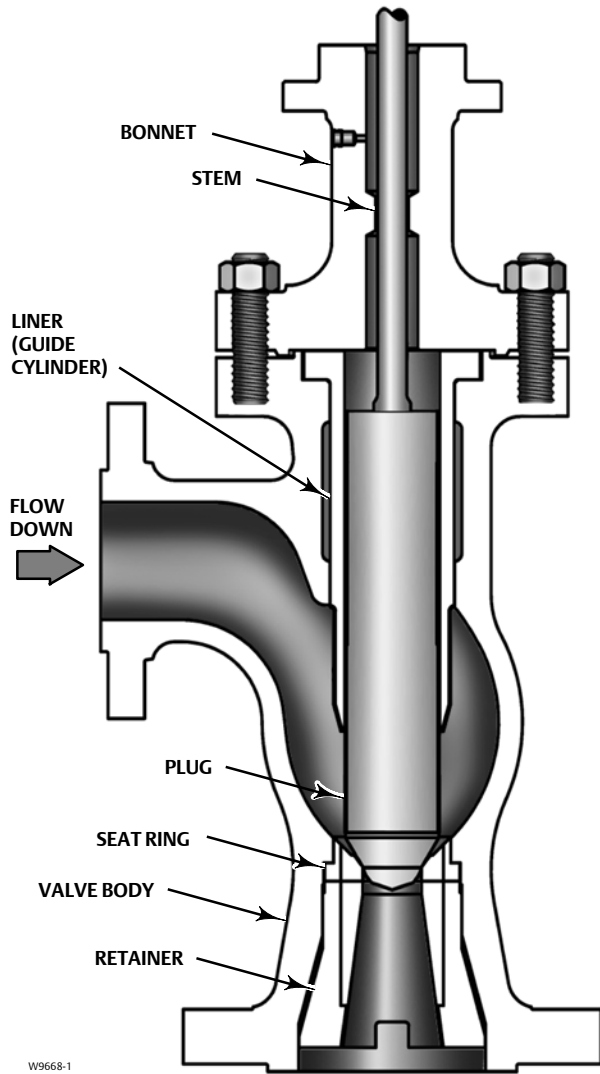

Figure 3. Fisher 461 Valve with Extended Retainer - Open

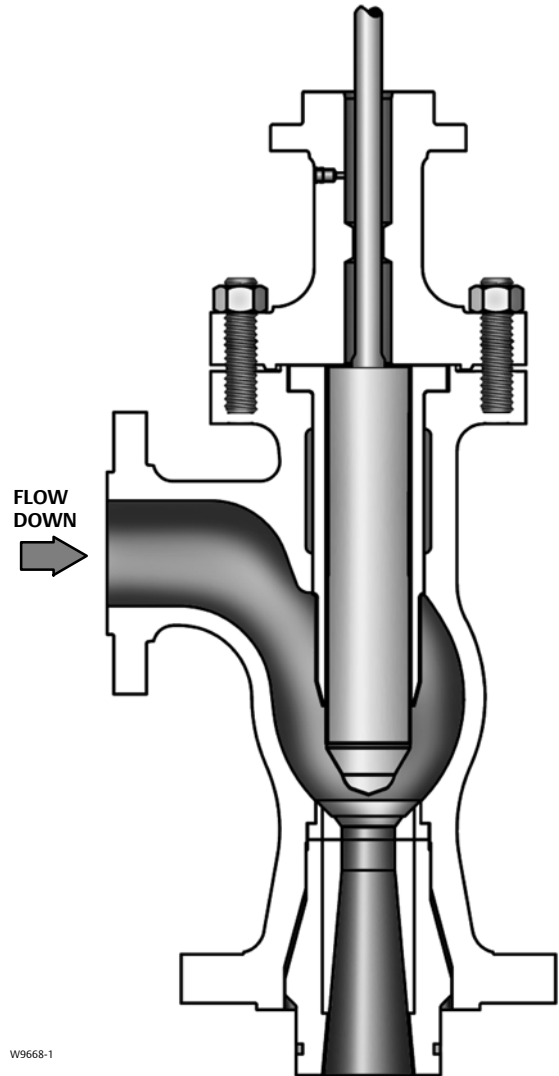
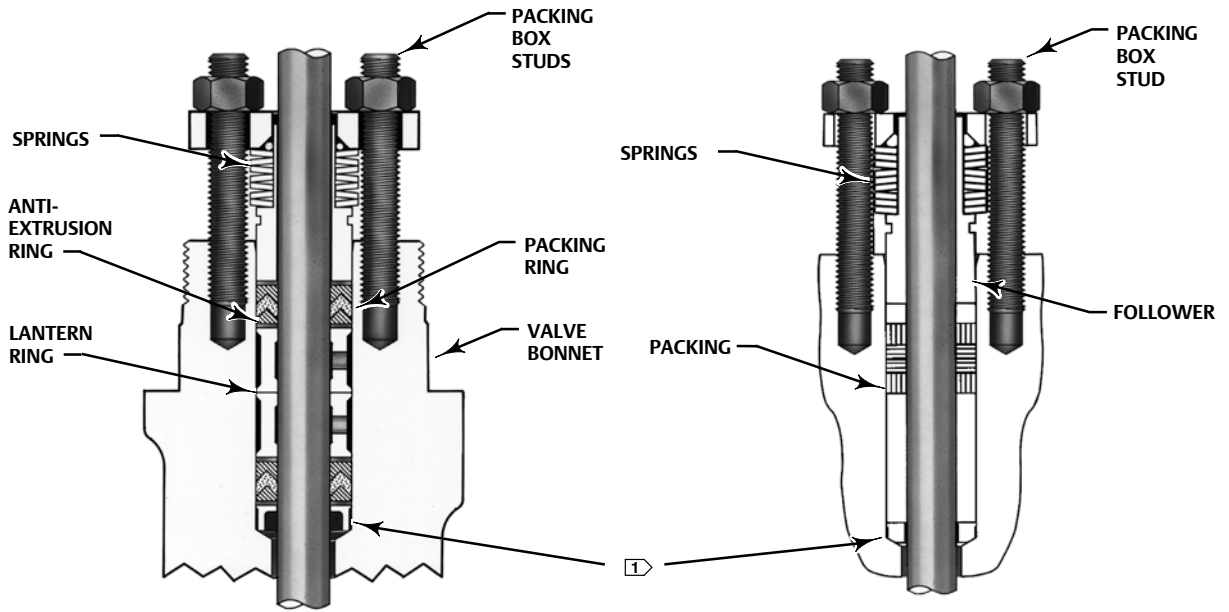

Figure 4. ENVIRO-SEAL and HIGH-SEAL Packing Systems



W5803-3

TYPICAL ENVIRO-SEAL PACKING SYSTEM WITH PTFE PACKING

W8532-1

TYPICAL ENVIRO-SEAL PACKING SYSTEM WITH GRAPHITE ULF PACKING

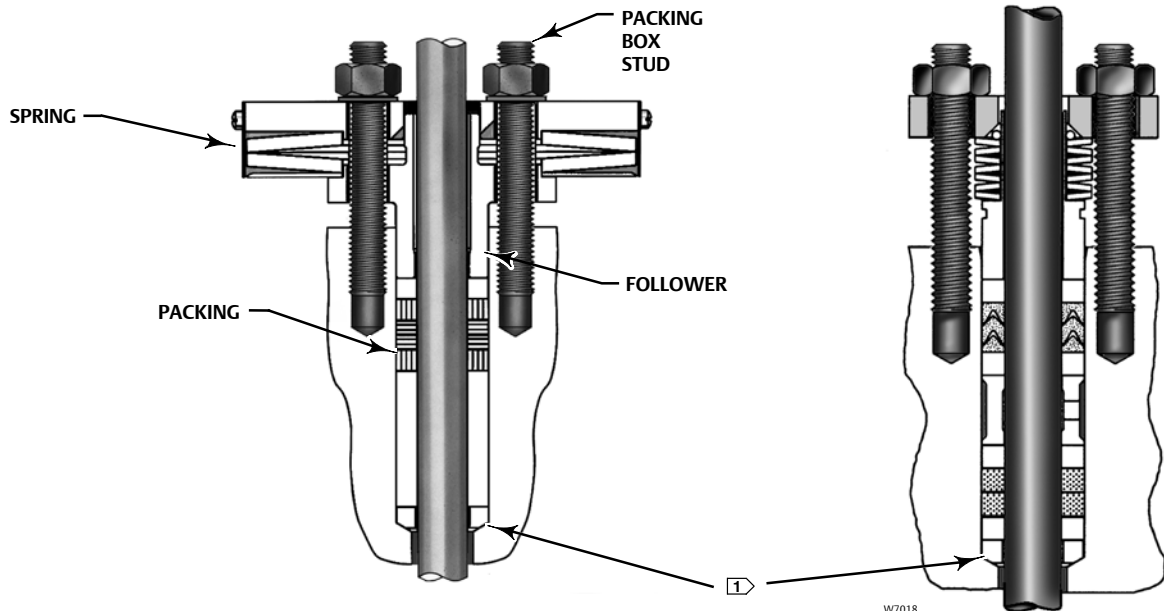

W8533-1

TYPICAL HIGH-SEAL PACKING SYSTEM WITH GRAPHITE ULF PACKING

W7018

TYPICAL ENVIRO-SEAL PACKING SYSTEM WITH DUPLEX PACKING

1 For a flat bottom packing box, the packing box ring and lower wiper are not needed.

Figure 5. Packing Arrangements

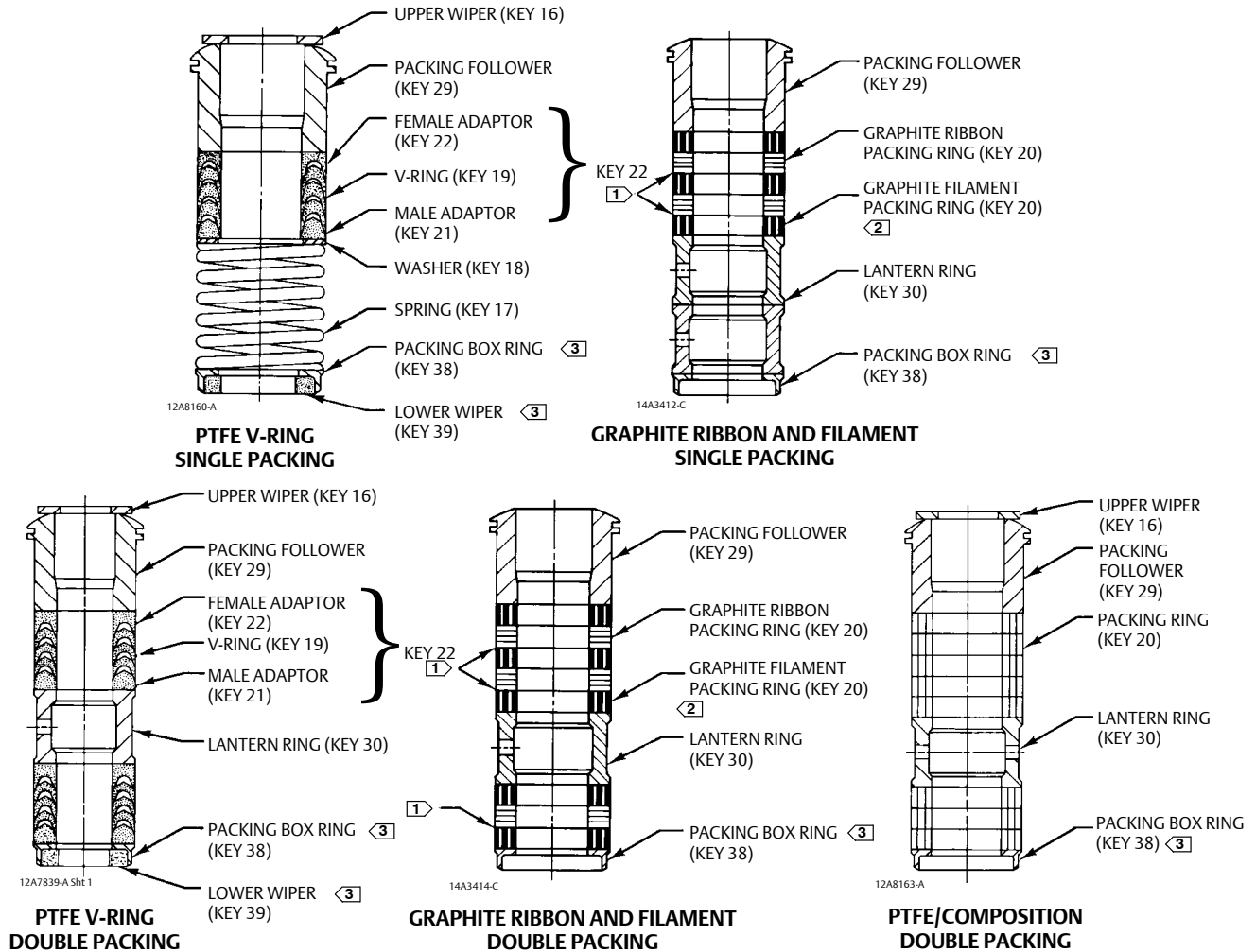

C0747-1

Notes:

- ① 0.102 mm (0.004 inch) thick sacrificial zinc washers. Use only one below each graphite ribbon ring.
- ② Has the appearance of a woven or braided ring.
- ③ For a flat bottom packing box, these parts are not needed.

Neither Emerson, Emerson Process Management, nor any of their affiliated entities assumes responsibility for the selection, use or maintenance of any product. Responsibility for proper selection, use, and maintenance of any product remains solely with the purchaser and end user.

Fisher and ENVIRO-SEAL are marks owned by one of the companies in the Emerson Process Management business unit of Emerson Electric Co. Emerson Process Management, Emerson, and the Emerson logo are trademarks and service marks of Emerson Electric Co. All other marks are the property of their respective owners.

The contents of this publication are presented for informational purposes only, and while every effort has been made to ensure their accuracy, they are not to be construed as warranties or guarantees, express or implied, regarding the products or services described herein or their use or applicability. All sales are governed by our terms and conditions, which are available upon request. We reserve the right to modify or improve the designs or specifications of such products at any time without notice.

Emerson Process Management

Marshalltown, Iowa 50158 USA
Sorocaba, 18087 Brazil
Chatham, Kent ME4 4QZ UK
Dubai, United Arab Emirates
Singapore 128461 Singapore

www.Fisher.com