

Type ACE97 Pad-Depad Valve

- Bubble Tight Shutoff
- Frictionless Pilot Valve
- Pilot Controlled
- Maximum Vapor Space Control
- Stainless Steel
- Self-Contained
- Diagnostics
- Fully Balanced

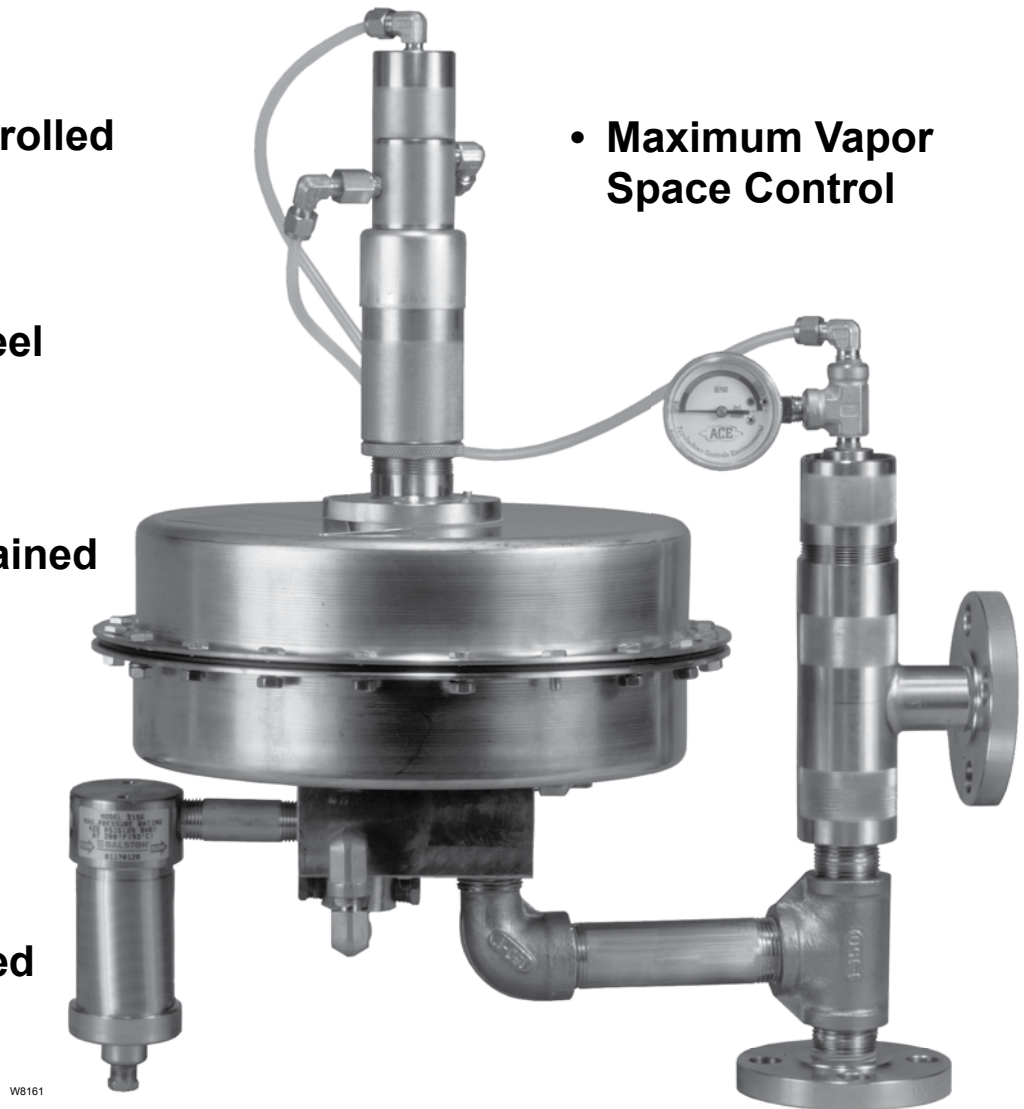

Figure 1. Type ACE97 Pad-Depad Valve



Bulletin 74.3:ACE97

Specifications

Pad Specifications

Pad Body Sizes

NPS 1/2, 1, and 2 / DN 15, 25, and 50

Maximum Operating Inlet Pressure⁽¹⁾

200 psig / 13.8 bar

Maximum Main Valve Inlet Pressure⁽¹⁾

200 psig 13.8 bar

Control Pressure Ranges⁽¹⁾

See Table 1

Maximum and Minimum Differential Pressures⁽¹⁾

Minimum: 25 psig / 1.7 bar

Maximum: 200 psig / 13.8 bar

Maximum Backpressure⁽¹⁾

20 psig / 1.4 bar

Flow Coefficients for Relief Valve Sizing

(110% of rated C_v)

$C_v = 0.2$ use $C_v = 0.22$

$C_v = 0.4$ use $C_v = 0.44$

$C_v = 1$ use $C_v = 1.1$

$C_v = 2$ use $C_v = 2.2$

$C_v = 4$ use $C_v = 4.4$

$C_v = 7.5$ use $C_v = 8.25$

$C_v = 10$ use $C_v = 11$

$C_v = 20$ use $C_v = 22$

$C_v = 45$ use $C_v = 50$

$C_v = 60$ use $C_v = 66$

Depad Specifications

Depad Body Sizes

NPS 1, 2, 3, and 4 / DN 25, 50, 80, and 100

Depad Pressure Ranges⁽¹⁾

See Table 1

Valve Coefficients

NPS 1 / DN 25 body: $C_v = 3$, $C_v = 12$, or $C_v = 17$

NPS 2 / DN 50 body: $C_v = 20$, $C_v = 35$, or $C_v = 70$

NPS 3 / DN 80 body: $C_v = 6$, $C_v = 90$, $C_v = 115$, or $C_v = 140$

NPS 4 / DN 100 body: $C_v = 150$, $C_v = 200$, or $C_v = 280$

General Type ACE97 Specifications

Pressure Registration

External

Temperature Capabilities

Nitrile (NBR):

-20 to 180°F / -29 to 82°C

Fluorocarbon (FKM):

0 to 212°F / -18 to 100°C

Ethylene propylene (EPDM - FDA):

-20 to 212°F / -29 to 100°C

Perfluoroelastomer (FFKM):

-20 to 212°F / -29 to 100°C

Construction Materials

Pad Body and Bonnet

NPS 1/2 and 1 / DN 15 and 25; $C_v = 0.2$ and $C_v = 0.4$:

316L Stainless steel

NPS 1 and 2 / DN 25 and 50; $C_v = 1$ to 4 and $C_v = 5$ to 10:

316 Stainless steel

NPS 2 / DN 50; $C_v = 20$ to 60:

CF3M/CF8M Stainless steel

Depad Body and Bonnet: 316 Stainless steel

Cage: 316 Stainless steel

Actuator: 316 Stainless steel

Trim: stainless steel

Elastomers: Nitrile (NBR), Fluorocarbon (FKM),

Perfluoroelastomer (FFKM), or

Ethylene propylene (EPDM - FDA)

Diaphragm: Nitrile (NBR), Fluorocarbon (FKM), or

Ethylene propylene (EPDM - FDA)

Approximate Weights

NPS 1/2 x 1 x 1 / DN 15 x 25 x 25:

70 pounds / 32 kg

NPS 1 x 2 x 2 / DN 25 x 50 x 50:

105 pounds / 48 kg

NPS 2 x 3 x 3 / DN 50 x 80 x 80:

175 pounds / 79 kg

1. The pressure/temperature limits in this Bulletin or any applicable standard limitation should not be exceeded.

Introduction

The Type ACE97 Pad-Depad valve is a self-contained, pilot-operated valve that maintains a blanket of inert gas on top of a stored product to protect it from atmospheric contamination. It reduces combustibility, decreases vaporization, controls vapor space pressure during pump-in and pump-out operations, and helps prevent the tank from entering a vacuum condition and collapsing upon itself. The Type ACE97 valve provides excellent and accurate pressure control of the vapor space in the tank. Blanketing pressure is kept to a minimum in order to conserve the use of blanketing gas.

Pad (Tank Blanketing) – ensures a minimum pressure is maintained in the tank vapor space during normal operation.

Depad (Vapor Recovery) – limits tank pressure to a maximum value during normal operation.

Tank and vapor recovery connections are available to meet most customer requirements. A Single Array Manifold (SAM) provides a single tank and sensing connection and is required for tanks having a single nozzle. Accessories include gauges, purge meters, pressure switches, and check valves.

Features and Benefits

Pilot Controlled: Type ACE97 valves (NPS 1 / DN 25 and larger) are pilot-operated for a higher degree of accuracy and control.

Fully Balanced: A fully balanced valve eliminates setpoint changes caused by variations in inlet pressure.

Options and Accessories

Inlet Pressure Gauge: Displays pressure of blanketing gas supply to the blanketing valve.

Control Pressure Gauge: Low-pressure gauge measures tank pressure.

Pressure Switch: Allows for the installation of an alarm system to indicate either low or high-pressure on the tank.

Flow Indicator: Provides a visual indication of blanketing gas flow.

Outlet Check Valve: Prevents corrosive gases and vapors from flowing back into the blanketing system.

Diagnostic Gauge: Allows analysis of valve operation in the field, simplifying service and reliability. (Only available on NPS 1 and 2 / DN 25 and 50 pad valve.)

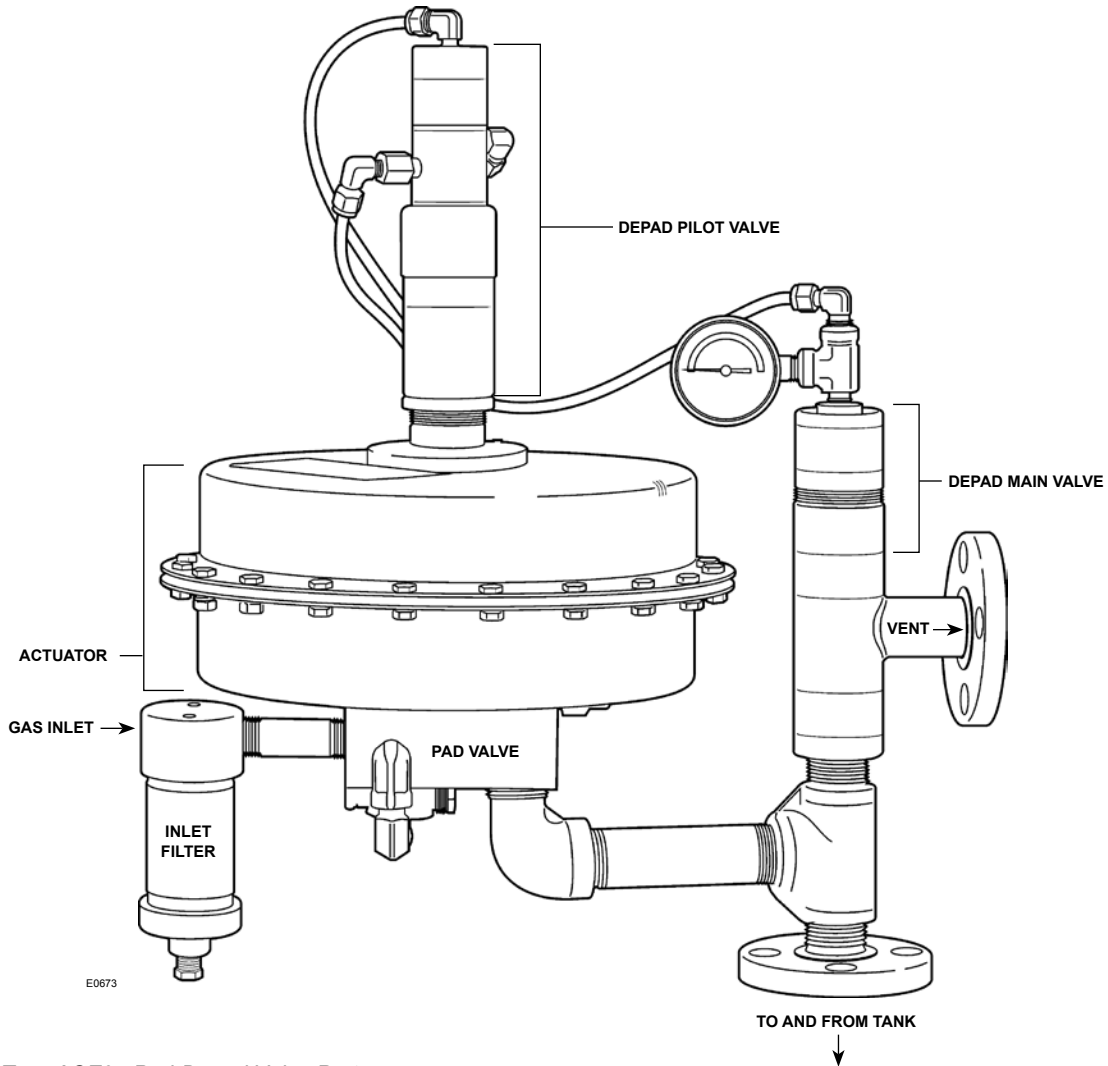

Figure 2. Type ACE97 Pad-Depad Valve Parts

Single Array Manifold (SAM): Provides sense line connection and main valve connection through a single tank nozzle.

Purge Meters: Prevents corrosive tank vapors from damaging upstream equipment.

Principle of Operation Pad (Figure 3)

NPS 1 and 2 / DN 25 and 50 Pad Valves (Figure 3)

When tank pressure decreases below the pad setpoint (due to pump out operations or thermal cooling), the actuator diaphragm moves downward pushing open the pad pilot. This creates flow from the pad loading chamber to downstream. When pad loading pressure decreases, the force created by inlet pressure on the pad main valve plug overcomes the main spring force and opens the main valve plug allowing flow through the pad valve to the tank. Once tank pressure reaches pad setpoint, the pad pilot closes, pad loading pressure equalizes with inlet pressure and the pad valve closes.

NPS 1/2 / DN 15 Pad Valves (Not Shown)

The NPS 1/2 / DN 15 Pad valve has a main valve only. When tank pressure decreases below the pad setpoint the actuator diaphragm

moves downward pushing the valve plug open and allowing flow through the pad valve to the tank.

Depad (Figure 4)

When tank pressure increases above the depad setpoint (due to pump-in operations or thermal heating), the actuator diaphragm moves upward and pushes open the depad pilot. This releases depad loading pressure (nitrogen or other supply gas). When depad pilot loading pressure decreases, the depad main valve opens by a spring and allows flow from the tank to the vent or recovery system.

Diagnostics

Tank blanketing valves are often installed in locations that are difficult to access. Type ACE97 valves are available with a diagnostics feature that allows analysis of valve operation in the field, making maintenance easier and more reliable.

The diagnostics feature relies uses relationship of pressure in the pilot and main valve chambers to analyze valve performance.

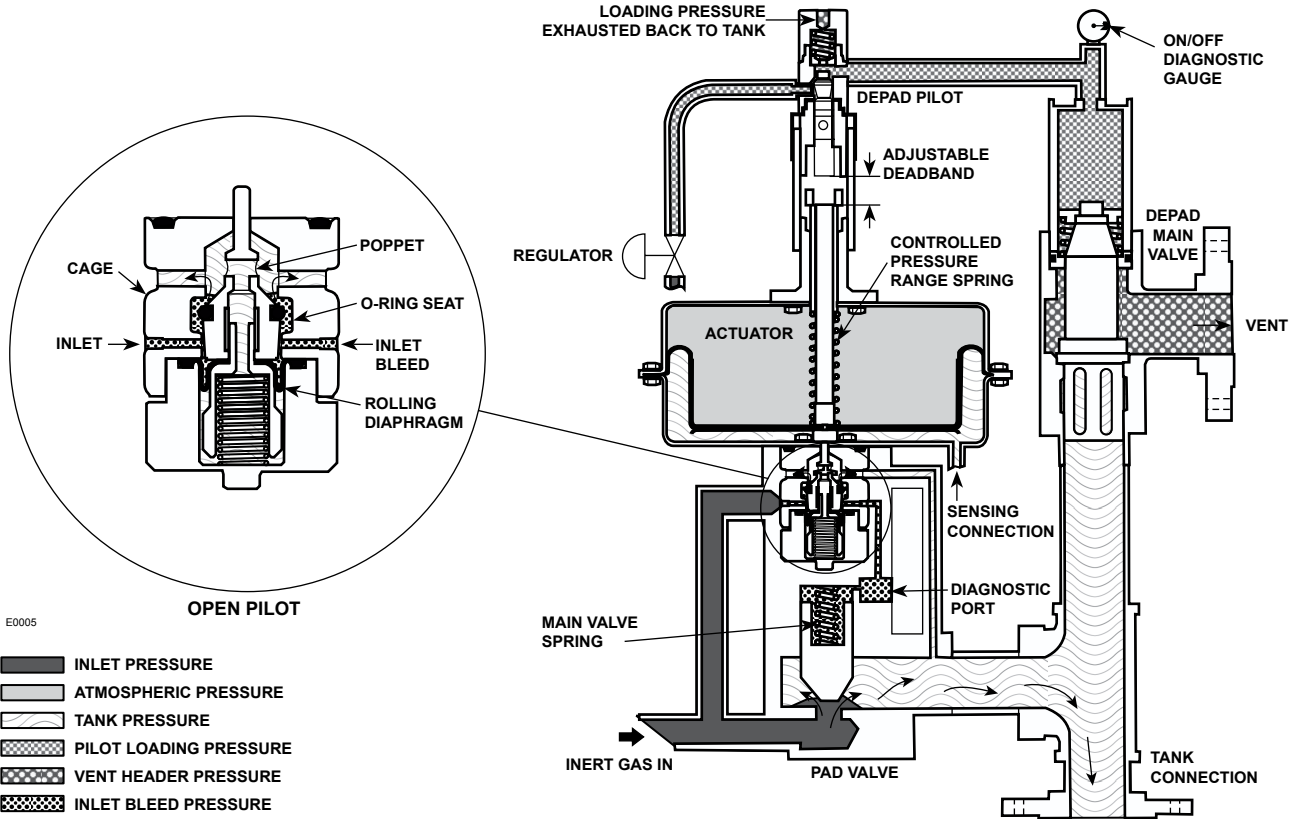

Figure 3. Type ACE97 Pad On / Depad Off

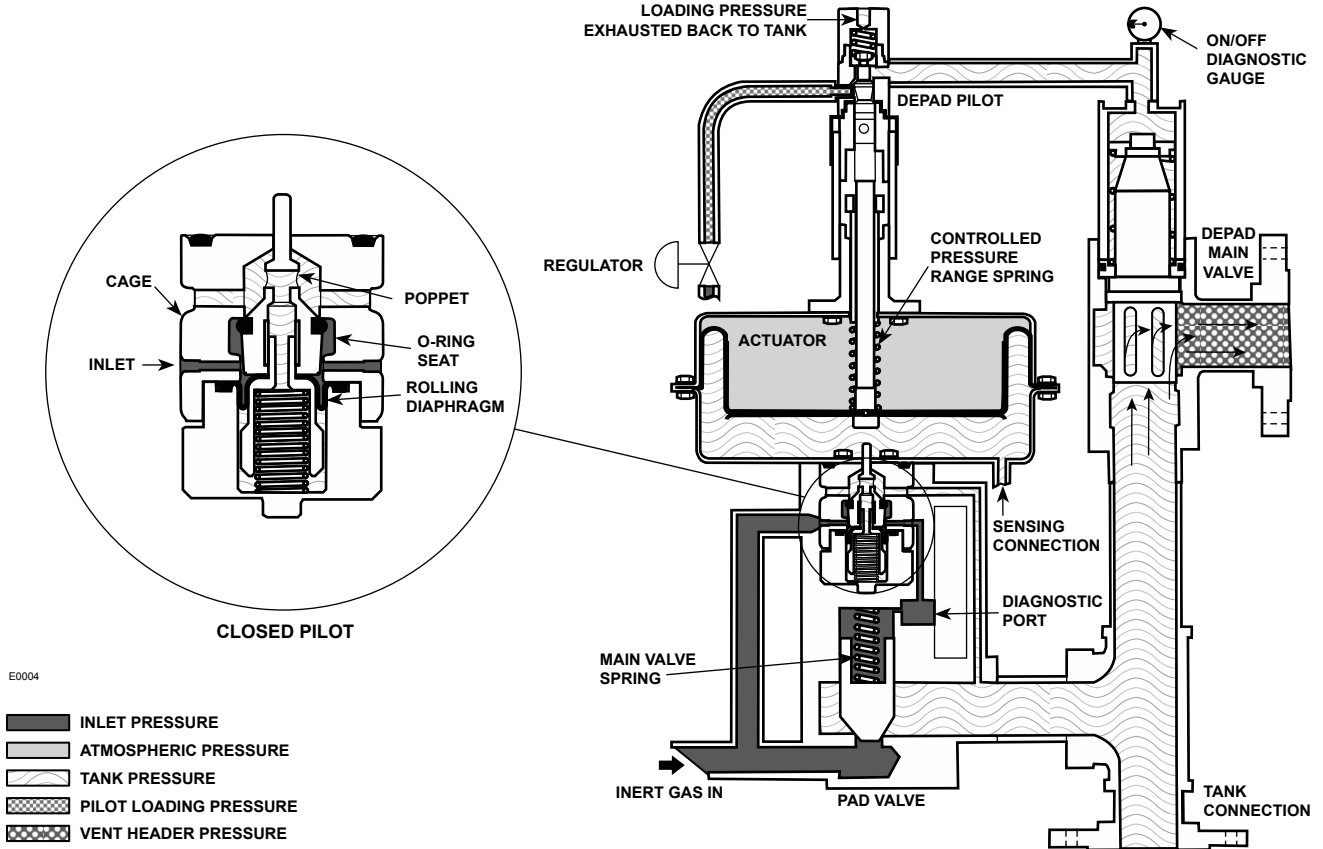

Figure 4. Type ACE97 Pad Off / Depad On

Table 1. Control Pressure Ranges

CONTROLLED PRESSURE RANGES				SPRING FREE LENGTH		SPRING WIRE DIAMETER	
Pad Setpoint		Depad Setpoint (Above Pad)		Inch	mm	Inch	mm
Inch w.c.	mbar	Inch w.c.	mbar				
0.5 to 3	1 to 7	4 to 10	10 to 25	3.08	78.2	0.105	2.67
0.5 to 7	1 to 17	4 to 6	10 to 15	4.00	102	0.092	2.34
3 to 13	7 to 32	4 to 16	10 to 40	3.73	94.7	0.156	3.96
4 to 10	10 to 25 ⁽¹⁾	16 to 78	40 to 194 ⁽¹⁾	3.73	94.7	0.156	3.96
4 to 10	10 to 25 ⁽¹⁾	16 to 78	40 to 194 ⁽¹⁾	2.90	73.7	0.250	6.35
0.5 to 1.4 psig	0.03 to 0.10 bar	0.25 to 1 psig	0.02 to 0.07 bar	3.80	96.5	0.250	6.35
1.0 to 2.2 psig	0.07 to 0.15 bar	0.25 to 2.0 psig	0.02 to 0.14 bar			0.313	7.95

1. Two nested springs are used.

System Sizing

Tank Blanketing systems must be properly sized to have capacity to supply enough blanketing gas to maintain the setpoint pressure, yet large enough to vent excess gas without having tank vapor space pressure rise above allowable limits. Pad valves must not be so large that they cause overpressure. Sizing must also take into account applicable codes and standards as they apply to the installation.

For proper sizing of the pad and depad valves, certain information is required. Proper sizing is essential to protect the product, the tank, the environment, and personnel.

Sizing Information

The following list contains all necessary information to properly size a valve once system parameters are determined. The customer must provide the following:

- Pump-in rate (for depad calculation)
- Pump-out rate (for pad calculation)
- Inert (blanketing) gas specific gravity
- Inert gas supply pressure (for pad selection)
- Tank volume (for API sizing both pad and depad)
- Stored fluid flash point (for API sizing depad)
- Stored fluid boiling point (for API sizing depad)
- Vent gas specific gravity (SG) (for API sizing depad)
- Depad setpoint
- Vent piping backpressure
- Sizing method (Direct Displacement or API 2000)

Direct Displacement

The direct displacement method should be used with extreme caution. The direct displacement method determines the amount of blanketing gas required to replace liquid pumped out of the tank and the amount of gas that must be removed due to liquid pump in. Direct displacement does not account for fluctuating temperature or other factors that may affect pressure in the vapor space. This method is typically applied to tanks containing non-flammable, non-volatile products.

Pad Sizing

$$Q_{\text{pad}} = Q_{\text{pump-out}}$$

where,

- Q_{pad} = Required Pad Flow Rate
- $Q_{\text{pump-out}}$ = Required Flow Rate for displacement due to pump-out (See Table 2)

Depad Sizing

$$Q_{\text{depad}} = Q_{\text{pump-in}}$$

where,

- Q_{depad} = Required Depad Flow Rate
- $Q_{\text{pump-out}}$ = Required Flow Rate for displacement due to liquid pump-in. (See Table 2)

API 2000

The American Petroleum Institute Standard 2000 (API 2000) sizing criteria accounts for liquid pump-in and pump-out as well as contraction and expansion of tank vapors due to heating and cooling. When using API 2000 methods:

Pad Sizing

$$Q_{\text{pad}} = Q_{\text{pump-out}} + Q_{\text{thermal}}$$

where,

- Q_{pad} = Required Pad Flow Rate
- $Q_{\text{pump-out}}$ = Required Flow Rate for displacement due to pump-out (See Table 5)
- Q_{thermal} = Required Flow Rate due to thermal cooling (See Table 6)

Depad Sizing

$$Q_{\text{depad}} = Q_{\text{pump-in}} + Q_{\text{thermal}}$$

where,

- Q_{pad} = Required Depad Flow Rate
- $Q_{\text{pump-in}}$ = Required Pump-In Rate (See Table 5)
- Q_{thermal} = Required Flow Rate due to thermal expansion (See Table 6)

Supplemental Venting

Depending on the method, there can be a significant difference in the calculated required capacity. **No matter which method is used, the tank must be equipped with supplemental venting to protect the tank, product, and personnel in cases of equipment failure, fire exposure, or other conditions that could cause the tank pressure or vacuum to exceed operating limits.**

Capacity Information

Pad Valves

In the case of pad valves, the tables are based on 0.97 specific gravity nitrogen. If it is desired to convert nitrogen flow rates of another gas, multiply the flow rate value from the capacity table by the following correction factor in Table 3.

Depad Valves

In the case of depad valves, the tables are based on air (1.0 specific gravity). Always use the differential pressure between tank pressure (depad setpoint) and vent header (vapor recovery) pressure to calculate flow through the depad valve.

Bulletin 74.3:ACE97

Table 2. Flow Rate Conversion

MULTIPLY MAXIMUM PUMP RATE	BY	TO OBTAIN:
U.S. GPM	8.021	SCFH
U.S. GPH	0.1337	SCFH
m ³ /hr	1.01	Nm ³ /h
Barrels/hr	5.615	SCFH
Barrels/day	0.2340	SCFH

Table 3. Correction Factors (For Converting Nitrogen Flow Rates to Other Gas Flow Rates)

BLANKET GAS	SPECIFIC GRAVITY	CORRECTION FACTOR
Natural Gas	0.60	1.27
Air	1.00	0.99
Dry CO ₂	1.52	0.80

$$\text{Correction Factor} = \frac{0.985}{\sqrt{\text{SG}}}$$

Table 4. Correction Factors (For Converting Air Flow Rates to Other Gas Flow Rates)

VENT GAS SPECIFIC GRAVITY	CORRECTION FACTOR
0.60	1.29
0.80	1.19
1.20	0.91
1.40	0.85
1.60	0.79
1.80	0.75
2.00	0.71
3.00	0.58

$$\text{Correction Factor} = \frac{1.00}{\sqrt{\text{SG}}}$$

Table 5. Flow Rate Requirements for Liquid Pump-In Pump-Out per API 2000

	PUMP-OUT (INBREATHING)	PUMP-IN (OUTBREATHING)
Flashpoint > 100°F / 38°C or Normal Boiling Point > 300°F / 149°C	5.6 SCFH / 0.15 Nm ³ /h of air per barrel/hour of liquid 8.0 SCFH / 0.21 Nm ³ /h of air per GPM of liquid 35.1 SCFH / 0.94 Nm ³ /h of air per m ³ /hr of liquid	6 barrels/hour of SCFH air per barrel/hour of liquid 8.6 SCFH / 0.23 Nm ³ /h of air per GPM of liquid 37.7 SCFH / 1.01 Nm ³ /h of air per m ³ /hr of liquid
Flashpoint < 100°F / 38°C or Normal Boiling Point < 300°F / 149°C	5.6 SCFH / 0.15 Nm ³ /h of air per barrel/hour of liquid 8.0 SCFH / 0.21 Nm ³ /h of air per GPM of liquid 35.1 SCFH / 0.94 Nm ³ /h of air per m ³ /hr of liquid	12 SCFH / 0.32 Nm ³ /h of air per barrel/hour of liquid 17 SCFH / 0.46 Nm ³ /h of air per GPM of liquid 75.3 SCFH / 2.02 Nm ³ /h of air per m ³ /hr of liquid

Table 6. Gas Flow Required for Thermal Cooling (Inbreathing) or Heating (Outbreathing) per API 2000 (Interpolate for Intermediate Sizes)

VESSEL CAPACITY			AIR FLOW RATE REQUIRED					
Barrels	Gallons	Liters	Inbreathing		Outbreathing			
					Flashpoint < 100°F / 38°C or Normal Boiling Point < 300°F / 149°C		Flashpoint > 100°F / 38°C or Normal Boiling Point > 300°F / 149°C	
			SCFH	Nm ³ /h	SCFH	Nm ³ /h	SCFH	Nm ³ /h
60	2520	9500	60	1.61	40	1.07	60	1.61
100	4200	16,000	100	2.68	60	1.61	100	2.68
500	21,000	79,500	500	13.4	300	8.04	500	13.4
1000	42,000	159,000	1000	26.8	600	16.1	1000	26.8
2000	84,000	318,000	2000	53.6	1200	32.2	2000	53.6
3000	126,000	477,000	3000	80.4	1800	48.2	3000	80.4
4000	168,000	636,000	4000	107	2400	64.3	4000	107
5000	210,000	795,000	5000	134	3000	80.4	5000	134
10,000	420,000	1,590,000	10,000	268	6000	161	10,000	268
15,000	630,000	2,385,000	15,000	402	9000	241	15,000	402
20,000	840,000	3,180,000	20,000	536	12,000	322	20,000	536
25,000	1,050,000	3,975,000	24,000	643	15,000	402	24,000	643
30,000	1,260,000	4,769,000	28,000	750	17,000	456	28,000	750
35,000	1,470,000	5,564,000	31,000	831	19,000	509	31,000	831
40,000	1,680,000	6,359,000	34,000	911	21,000	563	34,000	911
45,000	1,890,000	7,154,000	37,000	992	23,000	616	37,000	992
50,000	2,100,000	7,949,000	40,000	1072	24,000	643	40,000	1072
60,000	2,520,000	9,539,000	44,000	1179	27,000	724	44,000	1179
70,000	2,940,000	11,129,000	48,000	1286	29,000	777	48,000	1286
80,000	3,360,000	12,719,000	52,000	1394	31,000	831	52,000	1394
90,000	3,780,000	14,309,000	56,000	1501	34,000	911	56,000	1501
100,000	4,200,000	15,899,000	60,000	1608	36,000	965	60,000	1608
120,000	5,040,000	19,079,000	68,000	1822	41,000	1099	68,000	1822
140,000	5,880,000	22,258,000	75,000	2010	45,000	1206	75,000	2010
160,000	6,720,000	25,438,000	82,000	2198	50,000	1340	82,000	2198
180,000	7,560,000	28,618,000	90,000	2412	54,000	1447	90,000	2412

Table 7. NPS 1/2 / DN 15 Pad Valve Capacities of 0.97 Specific Gravity Nitrogen

INLET PRESSURE				CAPACITIES IN SCFH / Nm ³ /h OF NITROGEN			
				C _v = 0.2		C _v = 0.4	
psig	bar	kg/cm ²	kPa	SCFH	Nm ³ /h	SCFH	Nm ³ /h
25	1.7	1.8	172	250	6.7	550	14.7
30	2.1	2.1	207	290	7.8	630	16.9
40	2.8	2.8	276	370	9.9	780	20.9
50	3.4	3.5	345	450	12.1	930	24.9
60	4.1	4.2	414	530	14.2	1070	28.7
70	4.8	4.9	483	610	16.3	1230	33.0
80	5.5	5.6	552	690	18.5	1390	37.3
90	6.2	6.3	621	780	20.9	1560	41.8
100	6.9	7.0	690	860	23.0	1720	46.1
120	8.3	8.4	828	1020	27.3	2040	54.7
140	9.7	9.8	966	1180	31.6	2360	63.2
160	11.0	11.2	1103	1340	35.9	2680	71.8
180	12.4	12.7	1241	1500	40.2	3000	80.4
200	13.8	14.1	1379	1660	44.5	3330	89.2

Table 8. NPS 1 / DN 25 Pad Valve Capacities of 0.97 Specific Gravity Nitrogen

INLET PRESSURE				CAPACITIES IN SCFH / Nm ³ /h OF NITROGEN									
				C _v = 1		C _v = 2		C _v = 4		C _v = 7.5		C _v = 10	
psig	bar	kg/cm ²	kPa	SCFH	Nm ³ /h	SCFH	Nm ³ /h	SCFH	Nm ³ /h	SCFH	Nm ³ /h	SCFH	Nm ³ /h
25	1.7	1.76	172	1330	35.6	2670	71.6	5350	143	10,000	268	13,000	348
30	2.1	2.11	207	1510	40.5	3020	80.9	6050	162	11,300	303	15,100	405
40	2.8	2.81	276	1870	50.1	3750	101	7510	201	14,000	375	18,700	501
50	3.4	3.52	345	2280	61.1	4570	122	9140	245	17,100	458	22,800	611
60	4.1	4.22	414	2690	72.1	5380	144	10,700	287	20,100	539	26,900	721
70	4.8	4.92	483	3090	82.8	6180	166	12,300	330	23,200	622	30,000	804
80	5.5	5.62	552	3490	93.5	6990	187	13,900	373	26,200	702	34,900	935
90	6.2	6.33	621	3900	105	7800	209	15,600	418	29,200	783	39,000	1045
100	6.9	7.03	690	4300	115	8600	230	17,200	461	32,200	863	43,000	1152
110	7.6	7.73	759	4700	126	9410	252	18,800	504	35,300	946	47,000	1260
120	8.3	8.44	827	5100	137	10,200	273	20,400	547	38,300	1026	51,000	1367
130	9.0	9.14	897	5510	148	11,000	295	22,000	590	41,300	1107	55,100	1477
140	9.7	9.84	965	5910	158	11,800	316	23,600	632	44,300	1187	59,100	1584
150	10.3	10.55	1034	6310	169	12,600	338	25,200	675	47,300	1268	63,100	1691
160	11.0	11.25	1103	6710	180	13,400	359	26,800	718	50,300	1348	67,100	1798
170	11.7	11.95	1172	7120	191	14,200	381	28,400	761	53,400	1431	71,200	1908
180	12.4	12.65	1241	7520	202	15,000	402	30,000	804	56,400	1512	75,200	2015
190	13.1	13.36	1310	7920	212	15,800	423	31,700	850	59,400	1592	79,200	2123
200	13.8	14.06	1379	8320	223	16,600	445	33,300	892	62,400	1672	83,200	2230

Typical accuracy when flowing 5 to 70% of table value is ± 0.5 inch w.c. / 1 mbar.

Table 9. NPS 2 / DN 50 Pad Valve Capacities of 0.97 Specific Gravity Nitrogen

INLET PRESSURE				CAPACITIES IN SCFH / Nm ³ /h OF NITROGEN					
				C _v = 20		C _v = 45		C _v = 60	
psig	bar	kg/cm ²	kPa	SCFH	Nm ³ /h	SCFH	Nm ³ /h	SCFH	Nm ³ /h
25	1.7	1.76	172	26,700	716	60,200	1613	80,000	2144
30	2.1	2.11	207	30,200	809	68,100	1825	90,800	2433
40	2.8	2.81	276	37,500	1005	84,500	2265	112,700	3020
50	3.4	3.52	345	45,700	1225	102,800	2755	137,100	3674
60	4.1	4.22	414	53,800	1442	121,000	3243	161,400	4326
70	4.8	4.92	483	61,800	1656	139,200	3731	185,600	4974
80	5.5	5.62	552	69,900	1873	154,400	4138	209,800	5623
90	6.2	6.33	621	78,000	2090	175,500	4703	234,000	6271
100	6.9	7.03	690	86,000	2305	193,600	5188	258,200	6920
125	8.6	8.79	862	102,100	2736	238,900	6403	306,500	8214
150	10.3	10.55	1034	126,300	3385	284,200	7617	378,900	10,155
175	12.1	12.31	1207	142,400	3816	329,400	8828	427,200	11,449
200	13.8	14.06	1379	166,500	4462	347,700	9318	499,600	13,389

Typical accuracy when flowing 5 to 70% of table value is ± 0.5 inch w.c. / 1 mbar.

Bulletin 74.3:ACE97

Table 10. NPS 1 / DN 25 Depad Valve Capacities of 1.0 Specific Gravity Air

DIFFERENTIAL PRESSURE ⁽¹⁾		FLOW CAPACITY IN SCFH / Nm ³ /h OF 1.0 SPECIFIC GRAVITY AIR							
		C _v = 3		C _v = 6		C _v = 12		C _v = 17	
Inch w.c.	mbar	SCFH	Nm ³ /h	SCFH	Nm ³ /h	SCFH	Nm ³ /h	SCFH	Nm ³ /h
2	5	180	4.8	360	9.6	730	19.6	1030	27.6
3	7	220	5.9	440	11.8	890	23.9	1260	33.8
4	10	250	6.7	510	13.7	1030	27.6	1460	39.1
5	12	280	7.5	570	15.3	1150	30.8	1630	43.7
6	15	310	8.3	630	16.9	1260	33.8	1790	48.0
7	17	340	9.1	680	18.2	1360	36.4	1930	51.7
8	20	360	9.6	730	19.6	1460	39.1	2060	55.2
9	22	380	10.2	770	20.6	1540	41.3	2190	58.7
10	25	400	10.7	810	21.7	1630	43.7	2310	61.9
12	30	440	11.8	890	23.9	1780	47.7	2530	67.8
14	35	480	12.9	960	25.7	1930	51.7	2730	73.2
16	40	510	13.7	1030	27.6	2060	55.2	2920	78.3
18	45	540	14.5	1090	29.2	2190	58.7	3100	83.1
20	50	570	15.3	1150	30.8	2300	61.6	3270	87.6
22	55	600	16.1	1210	32.4	2420	64.9	3430	91.9
24	60	630	16.9	1260	33.8	2520	67.5	3580	95.9
26	65	650	17.4	1310	35.1	2630	70.5	3720	99.7
28	70	680	18.2	1360	36.5	2730	73.2	3870	104
30	75	700	18.8	1410	37.8	2820	75.6	4000	107
1.0 psig	69	670	18.0	1350	36.2	2710	72.6	3840	103
1.1 psig	76	710	19.0	1420	38.1	2840	76.1	4030	108
1.2 psig	83	740	19.8	1480	39.7	2970	79.6	4210	113
1.3 psig	90	770	20.6	1540	41.3	3090	82.8	4380	117
1.4 psig	97	800	21.4	1600	42.9	3210	86.0	4550	122
1.5 psig	103	830	22.2	1660	44.5	3320	89.0	4710	126
1.6 psig	110	850	22.8	1710	45.8	3430	91.9	4870	130
1.7 psig	117	880	23.6	1770	47.4	3540	94.9	5020	134
1.8 psig	124	910	24.4	1820	48.8	3640	97.6	5160	138
1.9 psig	131	930	24.9	1870	50.1	3740	100	5300	142
2.0 psig	138	960	25.7	1920	51.5	3840	103	5440	146
2.1 psig	145	980	26.3	1970	52.8	3940	106	5580	149
2.2 psig	152	1000	26.8	2010	53.9	4030	108	5710	153
2.3 psig	159	1030	27.6	2060	55.2	4120	110	5840	156
2.4 psig	165	1050	28.1	2100	56.3	4210	113	5970	160
2.5 psig	172	1070	28.7	2150	57.6	4300	115	6090	163
2.6 psig	179	1090	29.2	2190	58.7	4380	117	6210	166
2.7 psig	186	1110	29.7	2230	59.8	4470	120	6330	170
2.8 psig	193	1130	30.3	2270	60.8	4550	122	6450	173

1. Always use the differential pressure between tank pressure (depad setpoint) and vent header (vapor recovery) pressure to calculate flow through the depad valve.

Table 11. NPS 2 / DN 50 Depad Valve Capacities of 1.0 Specific Gravity Air

DIFFERENTIAL PRESSURE ⁽¹⁾		FLOW CAPACITY IN SCFH / Nm ³ /h OF 1.0 SPECIFIC GRAVITY AIR					
		C _v = 20		C _v = 35		C _v = 70	
Inch w.c.	mbar	SCFH	Nm ³ /h	SCFH	Nm ³ /h	SCFH	Nm ³ /h
2	5	1210	32.4	2130	57.1	4260	114
3	7	1490	39.9	2600	69.7	5210	140
4	10	1720	46.1	3010	80.7	6020	161
5	12	1920	51.5	3360	90.0	6730	180
6	15	2100	56.3	3680	98.6	7370	198
7	17	2270	60.8	3980	107	7970	214
8	20	2430	65.1	4260	114	8520	228
9	22	2580	69.1	4510	121	9030	242
10	25	2720	72.9	4760	128	9520	255
12	30	2980	79.9	5210	140	10,430	280
14	35	3220	86.3	5630	151	11,270	302
16	40	3440	92.2	6020	161	12,040	323
18	45	3650	97.8	6380	171	12,770	342
20	50	3840	103	6730	180	13,470	361
22	55	4030	108	7060	189	14,120	378
24	60	4210	113	7370	198	14,750	395
26	65	4380	117	7670	206	15,350	411
28	70	4550	122	7960	213	15,930	427
30	75	4710	126	8240	221	16,490	442
1.0 psig	69	4520	121	7920	212	15,800	423
1.1 psig	76	4740	127	8310	223	16,600	445
1.2 psig	83	4960	133	8680	233	17,300	464
1.3 psig	90	5160	138	9030	242	18,000	482
1.4 psig	97	5350	143	9370	251	18,700	501
1.5 psig	103	5540	148	9700	260	19,400	520
1.6 psig	110	5720	153	10,000	268	20,000	536
1.7 psig	117	5900	158	10,300	276	20,600	552
1.8 psig	124	6070	163	10,600	284	21,200	568
1.9 psig	131	6240	167	10,900	292	21,800	584
2.0 psig	138	6400	172	11,200	300	22,400	600
2.1 psig	145	6560	176	11,400	306	22,900	614
2.2 psig	152	6720	180	11,700	314	23,500	630
2.3 psig	159	6870	184	12,000	322	24,000	643
2.4 psig	165	7020	188	12,200	327	24,500	657
2.5 psig	172	7170	192	12,500	335	25,000	670
2.6 psig	179	7310	196	12,700	340	25,500	683
2.7 psig	186	7450	200	13,000	348	26,000	697
2.8 psig	193	7590	203	13,200	354	26,500	710

1. Always use the differential pressure between tank pressure (depad setpoint) and vent header (vapor recovery) pressure to calculate flow through the depad valve.

Bulletin 74.3:ACE97

Table 12. NPS 3 / DN 80 Depad Valve Capacities of 1.0 Specific Gravity Air

DIFFERENTIAL PRESSURE ⁽¹⁾		FLOW CAPACITY IN SCFH / Nm ³ /h OF 1.0 SPECIFIC GRAVITY AIR					
		C _v = 90		C _v = 115		C _v = 140	
Inch w.c.	mbar	SCFH	Nm ³ /h	SCFH	Nm ³ /h	SCFH	Nm ³ /h
2	5	5400	145	7000	188	8500	228
3	7	6700	180	8500	228	10,400	279
4	10	7700	206	9800	263	12,000	322
5	12	8600	230	11,000	295	13,400	359
6	15	9400	252	12,100	324	14,700	394
7	17	10,200	273	13,000	348	15,900	426
8	20	10,900	292	13,900	373	17,000	456
9	22	11,600	311	14,800	397	18,000	482
10	25	12,200	327	15,600	418	19,000	509
12	30	13,400	359	17,100	458	20,800	557
14	35	14,400	386	18,500	496	22,500	603
16	40	15,400	413	19,700	528	24,000	643
18	45	16,400	440	20,900	560	25,500	683
20	50	17,300	464	22,100	592	26,900	721
22	55	18,100	485	23,200	622	28,200	756
24	60	18,900	507	24,200	649	29,500	791
26	65	19,700	528	25,200	675	30,700	823
28	70	20,400	547	26,100	699	31,800	852
30	75	21,200	568	27,100	726	32,900	882
1.0 psig	69	20,300	544	26,000	697	31,600	847
1.1 psig	76	21,300	571	27,300	732	33,200	890
1.2 psig	83	22,300	598	28,500	764	34,700	930
1.3 psig	90	23,200	622	29,600	793	36,100	967
1.4 psig	97	24,100	646	30,800	825	37,500	1005
1.5 psig	103	24,900	667	31,800	852	38,800	1040
1.6 psig	110	25,700	689	32,900	882	40,100	1074
1.7 psig	117	26,500	710	33,900	909	41,300	1107
1.8 psig	124	27,300	732	34,900	935	42,500	1139
1.9 psig	131	28,100	753	35,900	962	43,700	1171
2.0 psig	138	28,800	772	36,800	986	44,800	1201
2.1 psig	145	29,500	791	37,700	1010	45,900	1230
2.2 psig	152	30,200	809	38,600	1034	47,000	1260
2.3 psig	159	30,900	828	39,500	1059	48,100	1289
2.4 psig	165	31,600	846	40,300	1080	49,100	1316
2.5 psig	172	32,200	863	41,200	1104	50,100	1343
2.6 psig	179	32,900	882	42,000	1126	51,100	1369
2.7 psig	186	33,500	898	42,800	1147	52,100	1396
2.8 psig	193	34,100	914	43,600	1168	53,100	1423

1. Always use the differential pressure between tank pressure (depad setpoint) and vent header (vapor recovery) pressure to calculate flow through the depad valve.

Table 13. NPS 4 / DN 100 Depad Valve Capacities of 1.0 Specific Gravity Air

DIFFERENTIAL PRESSURE ⁽¹⁾		FLOW CAPACITY IN SCFH / Nm ³ /h OF 1.0 SPECIFIC GRAVITY AIR					
		C _v = 150		C _v = 200		C _v = 280	
Inch w.c.	mbar	SCFH	Nm ³ /h	SCFH	Nm ³ /h	SCFH	Nm ³ /h
2	5	9100	244	12,100	324	17,000	456
3	7	11,100	297	14,900	399	20,800	557
4	10	12,900	346	17,200	461	24,100	646
5	12	14,400	386	19,200	515	26,900	721
6	15	15,800	423	21,000	563	29,500	791
7	17	17,000	456	22,700	608	31,800	852
8	20	18,200	488	24,300	651	34,000	911
9	22	19,300	517	25,800	691	36,100	967
10	25	20,400	547	27,200	729	38,100	1021
12	30	22,300	598	29,800	799	41,700	1118
14	35	24,100	646	32,200	863	45,000	1206
16	40	25,800	691	34,400	922	48,100	1289
18	45	27,300	732	36,500	978	51,100	1369
20	50	28,800	772	38,400	1029	53,800	1442
22	55	30,200	809	40,300	1080	56,500	1514
24	60	31,600	847	42,100	1128	59,000	1581
26	65	32,900	882	43,800	1174	61,400	1646
28	70	34,100	914	45,500	1219	63,700	1707
30	75	35,300	946	47,100	1262	65,900	1766
1.0 psig	69	33,900	909	45,200	1211	63,300	1696
1.1 psig	76	35,600	954	47,400	1270	66,400	1780
1.2 psig	83	37,200	997	49,600	1329	69,400	1860
1.3 psig	90	38,700	1037	51,600	1383	72,200	1935
1.4 psig	97	40,100	1075	53,500	1434	75,000	2010
1.5 psig	103	41,600	1115	55,400	1485	77,600	2080
1.6 psig	110	42,900	1150	57,200	1533	80,200	2149
1.7 psig	117	44,300	1187	59,000	1581	82,600	2214
1.8 psig	124	45,500	1219	60,700	1627	85,100	2281
1.9 psig	131	46,800	1254	62,400	1672	87,400	2342
2.0 psig	138	48,000	1286	64,000	1715	89,700	2404
2.1 psig	145	49,200	1319	65,600	1758	91,900	2463
2.2 psig	152	50,400	1351	67,200	1801	94,100	2522
2.3 psig	159	51,500	1380	68,700	1841	96,200	2578
2.4 psig	165	52,600	1410	70,200	1881	98,300	2634
2.5 psig	172	53,700	1439	71,700	1922	100,300	2688
2.6 psig	179	54,800	1469	73,100	1959	102,300	2742
2.7 psig	186	55,900	1498	74,500	1997	104,300	2795
2.8 psig	193	56,900	1525	75,900	2034	106,200	2846

1. Always use the differential pressure between tank pressure (depad setpoint) and vent header (vapor recovery) pressure to calculate flow through the depad valve.

Bulletin 74.3:ACE97

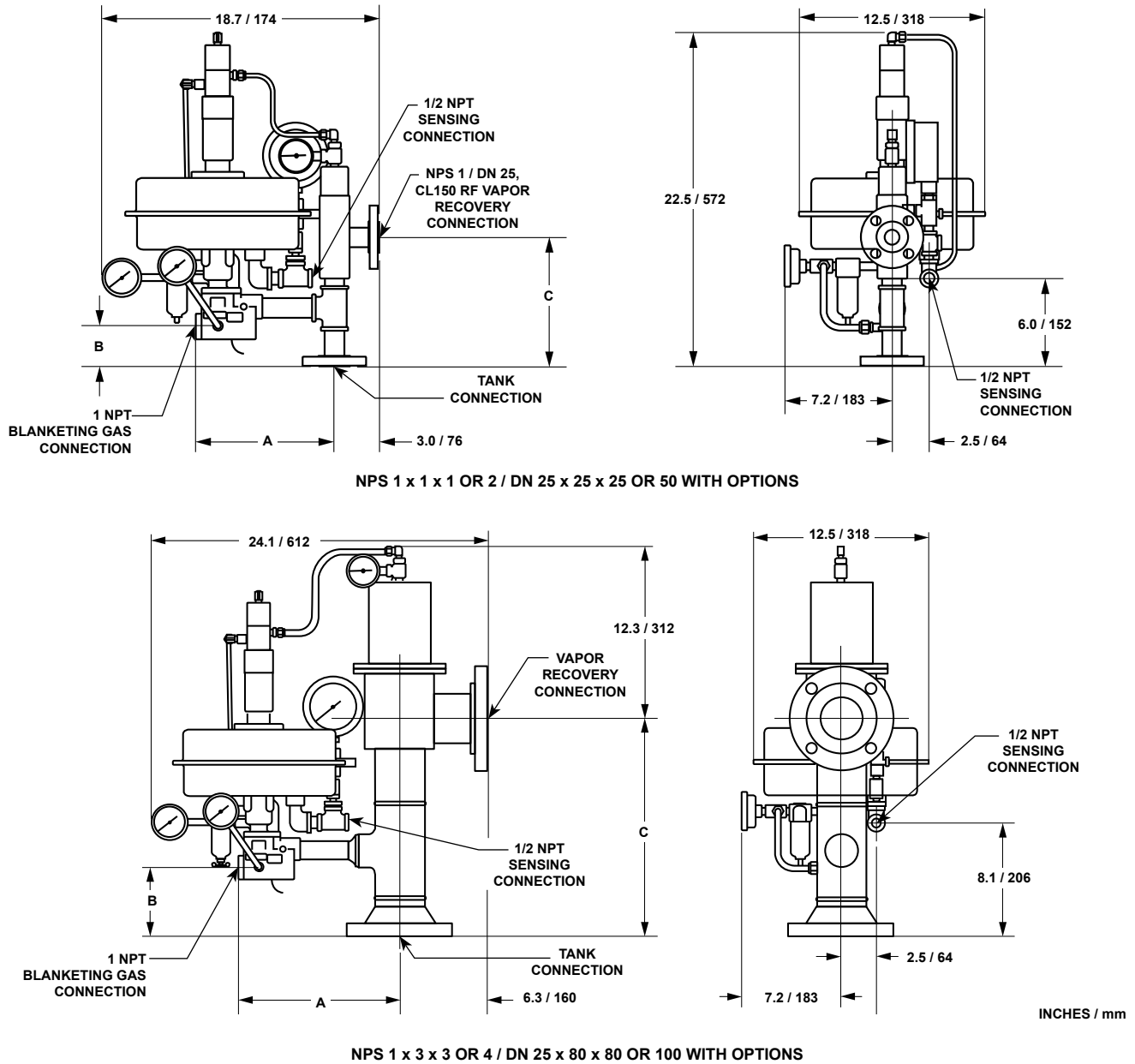
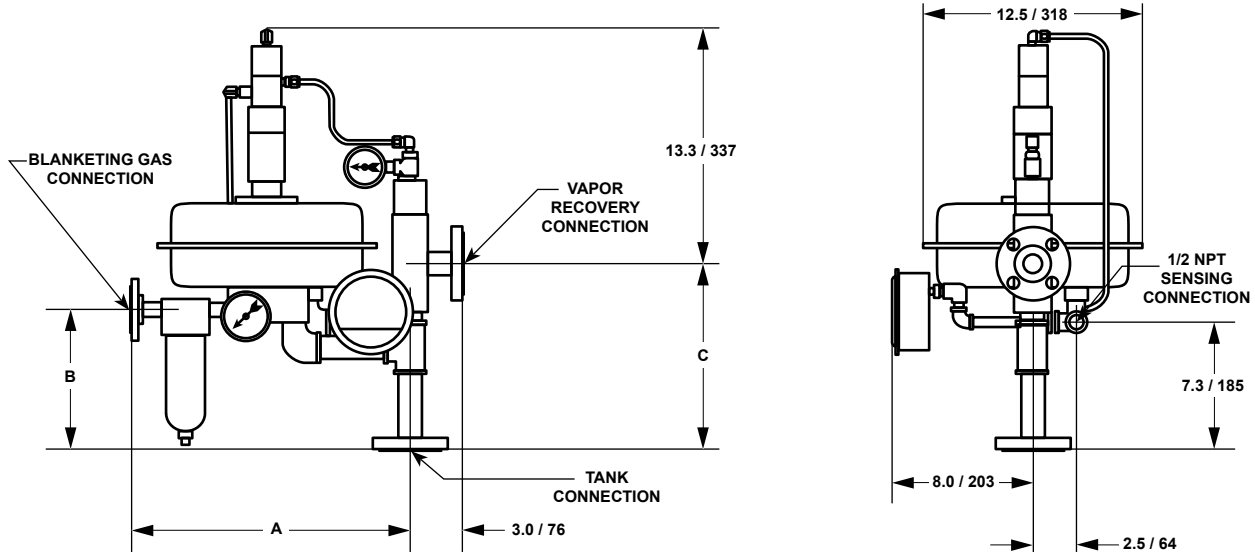

Figure 5. Type ACE97 Pad/Depad Valve Dimensions

Table 14. Type ACE97 Pad/Depad Valve Dimensions

DIMENSIONS IN INCH / mm FOR NPS 1 x 1 x 1 OR 2 / DN 25 x 25 x 25 OR 50 BODY WITH OPTIONS							
A		B		C			
NPT	CL150 RF	NPT	CL150 RF	NPT	CL150 RF		
9.4 / 239	11.5 / 292	0.3 / 7.6	2.8 / 71	6.3 / 160	8.8 / 224		

DIMENSIONS IN INCH / mm FOR NPS 1 x 3 x 3 OR 4 / DN 25 x 80 x 80 OR 100 BODY WITH OPTIONS							
A				B		C	
1 NPT	NPS 1 / DN 25, CL150 RF	NPS 1-1/2 / DN 40, CL150 RF	NPS 2 / DN 50, CL150 RF	3 NPT	NPS 3 or 4 / DN 80 or 100, CL150 RF	4 NPT	NPS 3 or 4 / DN 80 or 100, CL150 RF
11.5 / 292	16.9 / 429	17.2 / 437	17.4 / 442	5.3 / 135	4.9 / 124	5.8 / 147	15.6 / 396



NPS 1/2 x 1 x 1 OR 2 / DN 15 x 25 x 25 OR 50 WITH OPTIONS

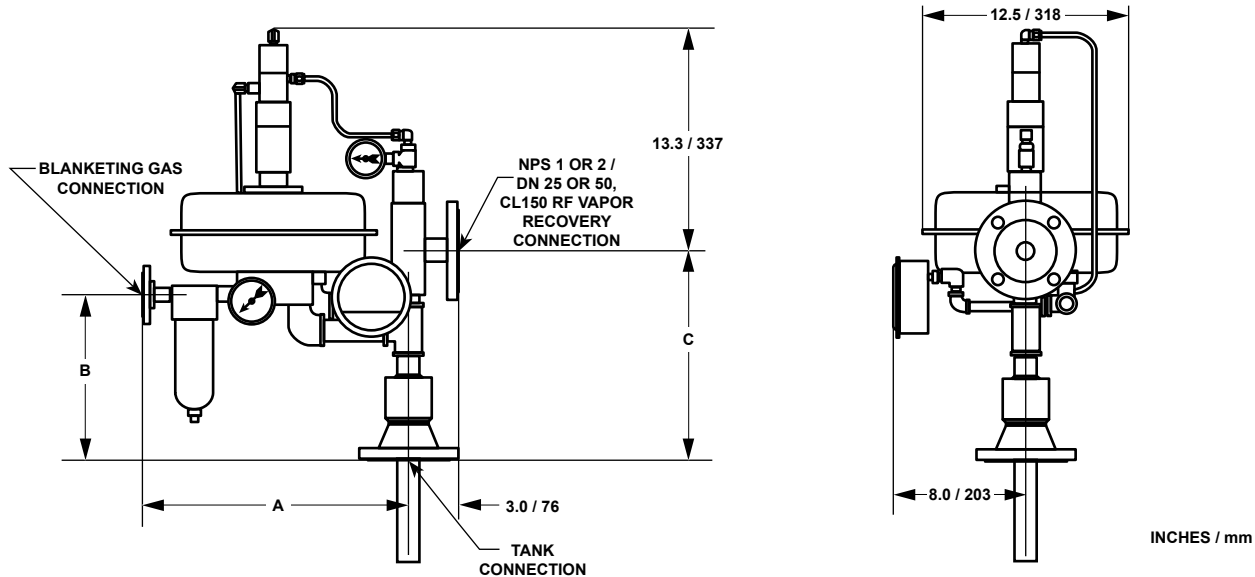

NPS 1/2 x 1 x 2 / DN 15 x 25 x 50 WITH SINGLE ARRAY MANIFOLD

Figure 5. Type ACE97 Pad/Depad Valve Dimensions (continued)

Table 14. Type ACE97 Pad/Depad Valve Dimensions (continued)

DIMENSIONS IN INCH / mm FOR NPS 1/2 x 1 x 1 OR 2 / DN 15 x 25 x 25 OR 50 BODY WITH OPTIONS							
A				B		C	
1/2 NPT Without Filter	1/2 NPT With Filter	NPS 1/2 / DN 15, CL150 RF Without Filter	NPS 1/2 / DN 15, CL150 RF With Filter	1 NPT	NPS 1 or 2 / DN 25 or 50, CL150 RF	1 NPT	NPS 1 or 2 / DN 25 or 50, CL150 RF
10.4 / 264	14.2 / 360	14 / 356	15.9 / 404	3.7 / 93	8 / 203	6.3 / 160	10.6 / 269

DIMENSIONS IN INCH / mm FOR NPS 1/2 x 1 x 2 / DN 15 x 25 x 50 BODY WITH SINGLE ARRAY MANIFOLD						
A				B		C
1/2 NPT Without Filter	1/2 NPT With Filter	NPS 1/2 or 1 / DN 15 or 25, CL150 RF Without Filter	NPS 1/2 or 1 / DN 15 or 25, CL150 RF With Filter	1 NPT	NPS 1 or 2 / DN 25 or 50, CL150 RF	NPS 2 / DN 50, CL150 RF
10.4 / 264	14.2 / 360	14 / 356	15.9 / 404	3.7 / 93	8 / 203	12.6 / 320

Bulletin 74.3:ACE97

Information Required

In order to complete the specification worksheet, the following information must be provided. Operating pressures and temperatures must be within the ranges listed within this bulletin.

Please specify measurement units: Imperial (USA) _____ or Metric _____

Pad Information

1. Maximum Inert Gas Flow - SCFH or Nm³/hr: _____ or Pad Valve Cv: _____
2. Inert Gas: _____ or Inert Gas Specific Gravity: _____
3. Supply Pressure, Inert Gas - Maximum: _____ Minimum: _____
4. Operating Temperature - °F: _____ or °C: _____
5. Pad Setpoint: _____ inches w.c. or mbar

Depad Information

6. Maximum Vent Gas Flow - SCFH or Nm³/hr: _____ or Depad Valve C_v: _____
7. Vent Gas Specific Gravity: _____
8. Vent Gas Temperature - °F: _____ or °C: _____
9. Depad Setpoint: _____ inches w.c. or mbar
10. Relief Header Pressure at Depad Outlet, Flowing Conditions, Maximum: _____ inches w.c. or mbar
11. Stored Liquid Flash Point - °F: _____ or °C: _____ or
Stored Liquid Boiling Point - °F: _____ or °C: _____ (*Require at least one for API sizing*)
12. Storage Temperature of Product - °F: _____ or °C: _____
13. Depad Materials of Construction Compatible with Stored Liquid and Vapors Metals: 316 SST or _____
Elastomers: Nitrile (NBR) _____, Fluorocarbon (FKM) _____, Ethylenepropylene (EPDM-FDA) _____,
Perfluoroelastomer (FFKM) _____, or Other _____
14. Product to be Blanketed: _____
15. Optional Equipment Required: _____
16. Emergency Pressure Vent Setpoint: _____ inches w.c. (separate device)

Connections

17. Inert Gas Supply - NPT: _____ Flanged: _____ Other (specify): _____
18. Tank Connection - NPT: _____ Flanged: _____ Other (specify): _____
19. Header Connection - NPT: _____ Flanged: _____ Other (specify): _____

Notes

If the required Pad or Depad valve C_v value is unknown, refer to the Sizing section for more details or contact your local Sales Office.
If the required Pad or Depad valve C_v value is known, continue with the Ordering worksheet.

Ordering Guide

Pad and Depad Valve Bodies (Select One)

- CF8M Stainless steel
- CF3M Stainless steel

Body Size and Coefficient (Select One from Each Category)

Pad Valve Body

- | | | |
|---|---|--|
| <i>NPS 1/2 / DN 15</i> | <i>NPS 1 / DN 25</i> | <i>NPS 2 / DN 50</i> |
| <input type="checkbox"/> C _v = 0.4 | <input type="checkbox"/> C _v = 1 | <input type="checkbox"/> C _v = 20 |
| <input type="checkbox"/> C _v = 0.2 | <input type="checkbox"/> C _v = 2 | <input type="checkbox"/> C _v = 45 |
| | <input type="checkbox"/> C _v = 4 | <input type="checkbox"/> C _v = 60 |
| | <input type="checkbox"/> C _v = 7.5 | |
| | <input type="checkbox"/> C _v = 10 | |

Depad Valve Body

- | | |
|---|---|
| <i>NPS 1 / DN 25</i> | <i>NPS 2 / DN 50</i> |
| <input type="checkbox"/> C _v = 3 | <input type="checkbox"/> C _v = 20 |
| <input type="checkbox"/> C _v = 6 | <input type="checkbox"/> C _v = 35 |
| <input type="checkbox"/> C _v = 12 | <input type="checkbox"/> C _v = 70 |
| <input type="checkbox"/> C _v = 17 | |
| <i>NPS 3 / DN 80</i> | <i>NPS 4 / DN 100</i> |
| <input type="checkbox"/> C _v = 90 | <input type="checkbox"/> C _v = 150 |
| <input type="checkbox"/> C _v = 115 | <input type="checkbox"/> C _v = 200 |
| <input type="checkbox"/> C _v = 140 | <input type="checkbox"/> C _v = 280 |

Pad Inlet Connection (Select One)

NPS 1/2 / DN 15 Body Size

- NPT
- CL150 RF threaded flange and nipple

NPS 1 / DN 25 Body Size

- NPT
- CL150 RF threaded flange and nipple

NPS 2 / DN 50 Body Size

- NPT
- CL150 RF threaded flange and nipple

Tank Connection (Must Match or be Larger than the Largest Pad or Depad Valve Body Size)

- NPS 1 / DN 25, CL150 RF
- NPS 2 / DN 50, CL150 RF
- NPS 3 / DN 80, CL150 RF
- NPS 4 / DN 100, CL150 RF

Diaphragm (Select One)

- Nitrile (NBR)
- Ethylenepropylene (EPDM - EPA)
- Fluorocarbon (FKM)

Other Elastomers (Select One)

- Nitrile (NBR)
- Ethylenepropylene (EPDM - EPA)
- Fluorocarbon (FKM)
- Perfluoroelastomer (FFKM)

Control Pressure Ranges - Pad Setpoint and Depad Setpoint (above Pad Setpoint) (Select One)

- Pad Setpoint:** 0.5 to 3-inches w.c. / 1 to 7 mbar
Depad Setpoint: 4 to 10-inches w.c. / 10 to 25 mbar
- Pad Setpoint:** 0.5 to 7-inches w.c. / 1 to 17 mbar
Depad Setpoint: 4 to 6-inches w.c. / 10 to 15 mbar
- Pad Setpoint:** 3 to 13-inches w.c. / 7 to 32 mbar
Depad Setpoint: 4 to 16-inches w.c. / 10 to 40 mbar
- Pad Setpoint:** 4 to 10-inches w.c. / 10 to 25 mbar
Depad Setpoint: 16 to 78-inches w.c. / 40 to 194 mbar
- Pad Setpoint:** 0.5 to 1.4 psig / 0.03 to 0.10 bar
Depad Setpoint: 0.25 to 1 psig / 0.02 to 0.07 bar
- Pad Setpoint:** 1 to 2.2 psig / 0.07 to 0.15 bar
Depad Setpoint: 0.25 to 2 psig / 0.02 to 0.14 bar

S.A.M. (Single Array Manifold) Tank Connection for a Single Nozzle Tank Connection (Optional)

- Yes No

Options (Select as many as Desired)

- Pad inlet pressure gauge, stainless steel
- Dwyer® control pressure gauge, 15 psig / 1.0 bar max
- 2 Dwyer® control pressure gauges (to span pad and depad setpoints)
- Control pressure gauge, above 4-inch w.c. / 10 mbar range, 4-inch / 102 mm diameter (max pressure limited to 130% of gauge span) with shutoff valve, stainless steel
- 2 control pressure gauges, same as above (to span pad and depad setpoints)
- Sensing line purge, stainless steel
- Main line purge, stainless steel
- Dwyer® XP pressure switch, aluminum housing
- Pad main line check valve for pad valve, stainless steel
- Diagnostic and inlet gauges (NPS 1 or 2 / DN 25 or 50 pad valve only)

Note: Standard sense line connection is 1/2 NPT.
Dwyer® is a mark owned by Dwyer Instruments Inc.

Industrial Regulators

Emerson Process Management Regulator Technologies, Inc.

USA - Headquarters
McKinney, Texas 75069-1872, USA
Tel: +1 800 558 5853
Outside U.S. +1 972 548 3574

Asia-Pacific
Shanghai 201206, China
Tel: +86 21 2892 9000

Europe
Bologna 40013, Italy
Tel: +39 051 419 0611

Middle East and Africa
Dubai, United Arab Emirates
Tel: +971 4811 8100

Natural Gas Technologies

Emerson Process Management Regulator Technologies, Inc.

USA - Headquarters
McKinney, Texas 75069-1872, USA
Tel: +1 800 558 5853
Outside U.S. +1 972 548 3574

Asia-Pacific
Singapore 128461, Singapore
Tel: +65 6770 8337

Europe
Bologna 40013, Italy
Tel: +39 051 419 0611
Chartres 28008, France
Tel: +33 2 37 33 47 00

TESCOM

Emerson Process Management Tescom Corporation

USA - Headquarters
Elk River, Minnesota 55330-2445, USA
Tels: +1 763 241 3238
+1 800 447 1250

Europe
Selmsdorf 23923, Germany
Tel: +49 38823 31 287

Asia-Pacific
Shanghai 201206, China
Tel: +86 21 2892 9499

For further information visit www.fisherregulators.com

The Emerson logo is a trademark and service mark of Emerson Electric Co. All other marks are the property of their prospective owners. Fisher is a mark owned by Fisher Controls International LLC, a business of Emerson Process Management.

The contents of this publication are presented for informational purposes only, and while every effort has been made to ensure their accuracy, they are not to be construed as warranties or guarantees, express or implied, regarding the products or services described herein or their use or applicability. We reserve the right to modify or improve the designs or specifications of such products at any time without notice.

Emerson Process Management Regulator Technologies, Inc. does not assume responsibility for the selection, use or maintenance of any product. Responsibility for proper selection, use and maintenance of any Emerson Process Management Regulator Technologies, Inc. product remains solely with the purchaser.