

Type 1367 High-Pressure Instrument Supply System with Overpressure Protection

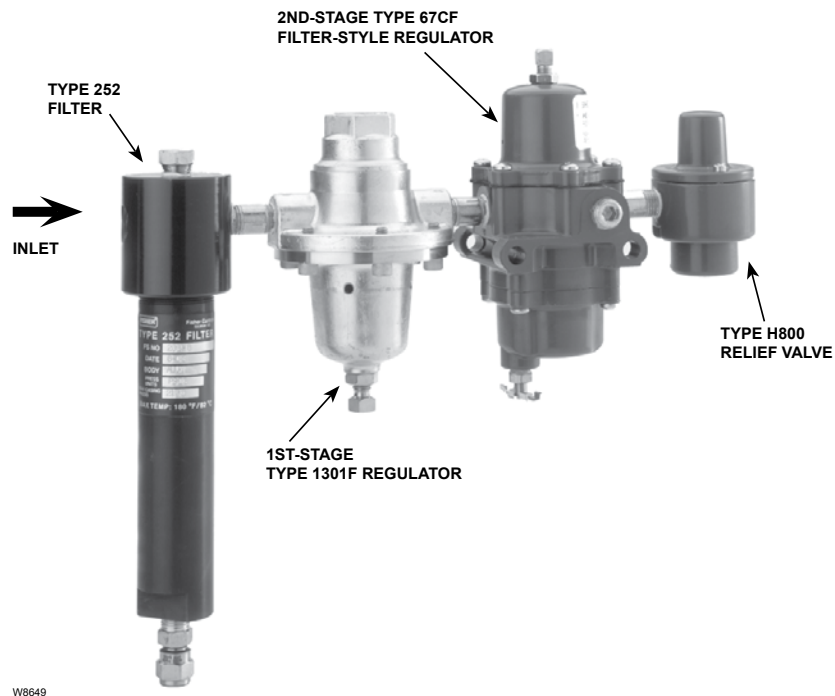

Figure 1. Type 1367 High-Pressure Instrument Supply System



WARNING

Failure to follow these instructions or to properly install and maintain this equipment could result in an explosion, fire and/or chemical contamination causing property damage and personal injury or death.

Fisher® regulators must be installed, operated, and maintained in accordance with federal, state, and local codes, rules and regulations, and Emerson Process Management Regulator Technologies Inc. instructions.

If the regulator vents gas or a leak develops in the system, service to the unit may be required. Failure to correct trouble could result in a hazardous condition.

Installation, operation, and maintenance procedures performed by unqualified personnel may result in improper adjustment and unsafe operation. Either condition may result in equipment damage or personal injury. Use qualified personnel when installing, operating, and maintaining the Type 1367 regulator.

Type 1367

Specifications

The Specifications table lists general Type 1367 instrument supply system specifications, while a nameplate wired to one of the pipe nipples gives the maximum inlet pressure and date of manufacture.

Connection Size Inlet and Outlet: 1/4 NPT Type H800 Vent: 1/2 NPT with removable screen	Maximum Outlet (Supply) Pressure with Type 67CF Regulator Failed Wide-Open with: Type H800 Relief Valve Relieving: 50 psig / 3.4 bar Type H120 (Second Stage) Relief Valve Relieving: 90 psig / 6.2 bar
Maximum Inlet Pressure⁽¹⁾ 2000 psig / 138 bar	Temperature Capabilities⁽¹⁾ -20 to 150°F / -29 to 66°C
Fixed Relief Setting of Type H120 Relief Valve 150 psig / 10.3 bar	Approximate Weight 12 pounds / 5.4 kg
Outlet (Supply) Pressure Range 5 to 70 psig / 0.35 to 4.8 bar	

1. The pressure/temperature limits in this Instruction Manual and any applicable standard or code limitation should not be exceeded.

Introduction

Scope of the Manual

This manual provides installation information on the Type 1367 high-pressure instrument supply system. For complete adjustment, maintenance, and parts information on the individual components of this system, refer to separate manuals for the Types 67CF and 1301F regulators, Type 252 filter, and Type H800 relief valve. Refer to other manuals for actuator, valve body, and instrument information.

Note

No instruction manual exists for the Type H120 relief valve, as this relief valve cannot be adjusted or repaired. Any maintenance on the Type H120 relief valve must be accomplished by replacing it as a complete unit.

Product Description

The Type 1367 high-pressure instrument supply system takes a pressure of up to 2000 psig / 138 bar and reduces it to a controlled pressure to be used for supplying a pneumatic instrument. This system consists of the following filters, regulators, and relief valves:

- A Type 252 extended body filter with drain valve.
- A first-stage Type 1301F regulator with mounting bracket for an actuator yoke or casing.

- A Type H120 relief valve mounted in the side outlet of the Type 1301F regulator.
- A second-stage Type 67CF filter-style regulator, mounted on the Type 1301F regulator.
- A Type H800 or H120 relief valve nipple-mounted in the outlet of the Type 67CF regulator.

Principle of Operation

The Type 252 filter helps remove dirt, rust, chips, scale, and moisture from the incoming high-pressure supply before it enters the Type 1301F regulator. The Type 1301F regulator is set to reduce this incoming high-pressure to 100 psig / 6.9 bar. The reduced pressure from the Type 1301F regulator is then further reduced between 20 and 70 psig / 1.4 or 4.8 bar to supply the pneumatic instrument. Although the Type 67CF regulator is normally set for 20 psig / 1.4 bar outlet pressure, it can be field-adjusted up to 35 psig / 2.4 bar outlet pressure.

The first stage Type H120 relief valve serves to protect the Type 67CF regulator by relieving if the reduced pressure from the Type 1301F regulator exceeds 150 psig / 10.3 bar. The Type H800 or H120 relief valve serves to protect downstream equipment from overpressure by relieving if the reduced pressure from the Type 67CF regulator exceeds the relief setpoint. Air or gas flowing from one or both of the relief valves indicates that one or both of the regulators are worn or damaged and must be repaired or replaced immediately.

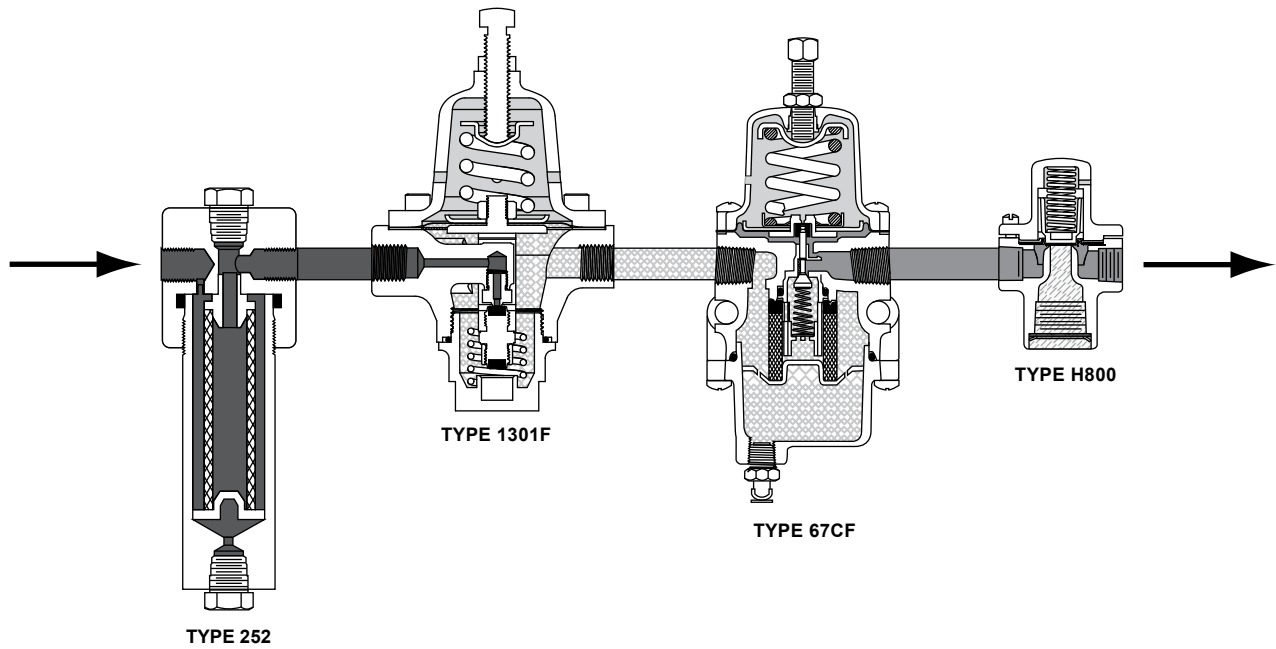

TYPE H120 RELIEF VALVE NOT SHOWN

- HIGH INLET PRESSURE
- ATMOSPHERIC PRESSURE
- INITIAL STEP-DOWN PRESSURE, 100 psig / 6.9 bar
- FINAL OUTLET PRESSURE, 10 to 35 psig / 0.69 to 2.4 bar
- RELIEF PRESSURE

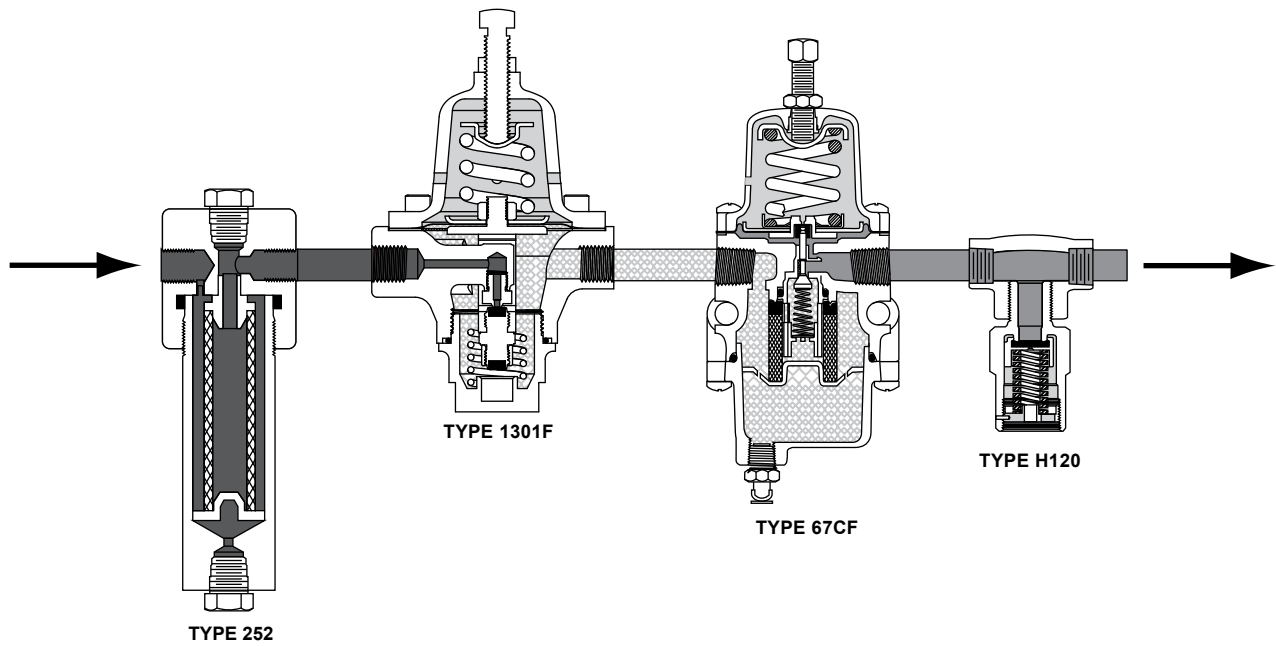

FIRST STAGE TYPE H120 RELIEF VALVE NOT SHOWN

- HIGH INLET PRESSURE
- ATMOSPHERIC PRESSURE
- INITIAL STEP-DOWN PRESSURE, 100 psig / 6.9 bar
- FINAL OUTLET PRESSURE, 10 to 35 psig / 0.69 to 2.4 bar
- RELIEF PRESSURE

Figure 2. Type 1367 Operational Schematic

Type 1367

Installation

All key numbers mentioned in this section appear in Figure 2.



WARNING

Installing a Type 1367 instrument supply system where its capabilities can be exceeded or where proper operation might be impaired may cause personal injury, property damage, or leakage due to bursting of pressure-containing parts or explosion of accumulated gas. To avoid such conditions:

- Use qualified service person to install the Type 1367 instrument supply system.
- Install the Type 1367 instrument supply system where it is protected from exposure to physical damage and/or corrosive substances.
- Install the instrument supply system where service conditions are within the unit capabilities specified in Specifications. Consult your local Sales Office if service conditions exceed Specifications capabilities.

Consult local Sales Office if service conditions exceed Specifications capabilities.

Impairment of proper operation includes permanently removing the Types H120 and H800 relief valves from their respective regulators and plugging the side outlet of the Type 1301F regulator.

Note

If the Type 1367 instrument supply system is shipped mounted on another unit, install that unit according to the appropriate instruction manuals.

With an instrument supply system that is shipped separately:

1. Make sure that there is no damage to the components.
2. Mount the bracket of the Type 1301F regulator (key 2) on the actuator yoke or casing.

Note

If using pipe in the following steps, apply thread tape or pipe compound to the pipe threads before making the connections.

3. Install tubing or piping into the 1/4 NPT inlet connection of the Type 252 filter (key 1) so that flow is in the proper direction as indicated on the filter head.
4. Install tubing or piping from the 1/4 NPT outlet (or side) connection of the Type H800 or tee of the Type H120 relief valve (key 5) to the pneumatic instrument.



WARNING

An instrument supply system may vent some gas to the atmosphere. In hazardous or flammable gas service, vented gas may accumulate, causing personal injury, death, or property damage due to fire or explosion. Vent a supply system in hazardous gas service to a remote, safe location away from air intakes or any hazardous location. The vent lines in both of the following steps must be protected against condensation or clogging.

5. To remotely vent gas from the 1/2 NPT vent (or bottom) connection of the Type H800 relief valve (key 5), remove the screen from the Type H800 vent. Then install the appropriate size piping or tubing into the Type H800 vent connection. The piping or tubing should vent the gas to a safe location, be as short and have as few bends as possible to minimize backpressure during relief valve operation, and have a screened vent on its exhaust end. Install any remote vent piping or tubing so that the vent is protected from condensation, freezing, or any substance that could clog it.
6. To remotely vent gas from the 1/4 NPT connection of the street elbow (key 7) or the pipe tee (key 10), remove the Type H120 relief valve (key 3 and/ or key 5) from the elbow or tee. Then install the appropriate size piping or tubing into the elbow. The piping or tubing should vent the gas to a safe location, and be as short as possible and have as

few bends as possible to minimize backpressure during relief valve operation. Reinstall the Type H120 relief on the remote end of the piping or tubing installed in the elbow.

Startup

With installation completed and downstream equipment adjusted, slowly open the upstream and downstream block valves while using pressure gauges to monitor pressure.

Adjustments

Unless specified otherwise, each instrument supply system is factory-set for a 20 psig / 1.34 bar outlet pressure. Consult the Types 67CF and 67CFR regulators instruction manual for the procedure to adjust the Type 67CF regulator (key 4, Figure 2) anywhere within its 5 to 70 psig / 0.35 to 4.8 bar outlet pressure range.

Shutdown

First, close the upstream shutoff valve, and then, close the downstream shutoff valve. Next, open the vent valve between the regulator and the downstream shutoff valve and open the vent valve between the regulator and the upstream shutoff valve. If vent valves are not installed, safely bleed off both inlet and outlet pressures and check that the regulator contains no pressure.

Maintenance

All key numbers mentioned in this section appear in Figure 2.

Type 1367 instrument supply systems parts are subject to normal wear and must be inspected and replaced as necessary. The frequency of inspection and parts replacement depends on the severity of service conditions and the requirements of local, state, and federal rules and regulations. The drain valves of both the Types 252 and 67CF regulators (keys 1 and 4) should be opened periodically to empty accumulated moisture.

Consult the appropriate instruction manual for maintenance procedures on each of the components of the Type 1367 instrument supply system.



WARNING

To avoid personal injury or equipment damage from sudden release of pressure or explosion of accumulated gas, do not attempt any maintenance or disassembly without first isolating the instrument supply system and associated equipment from system pressure and relieving all internal pressure from the instrument supply system and associated equipment.

To avoid personal injury or equipment damage due to impaired operation, make sure that the relief valves (keys 3 and 5) are directly or remotely installed into the appropriate outlets of the regulators (keys 2 and 4) after maintenance is completed.

Parts Ordering

When corresponding with your local Sales Office about this unit, include the date of manufacture from the nameplate and the type numbers and all other pertinent information from the nameplates and other identification appearing on each of the components. Specify the appropriate part number when ordering any new parts from the following list.

Parts List

To Provide Sour Gas Corrosion Resistance Capability⁽¹⁾

Key	Description	Part Number
1	Type 252 Filter	FS252-8 ⁽²⁾
2	Type 1301F Regulator	
	For yoke mounting	FS1301F-N2/M1 ⁽²⁾
	For casing mounting	FS1301F-N2/M3 ⁽²⁾
3	Type H120 Relief Valve	FSH120-N150
4	Type 67CF Regulator	FS67CF-N206 ⁽²⁾
5	Type H800 Relief Valve	FSH800-2 ⁽²⁾
6	Pipe Nipple, Plated Carbon steel (3 required)	-----
7	Street Elbow, Heat-treated steel	-----
8	Nameplate, Stainless steel (not shown)	-----
9	Wire, Monel [®] with Lead seal (not shown)	T12315T0012

1. As detailed in NACE international standard MR0175.

2. For entire assembly. See separate manual for individual part numbers.

Monel[®] is a trademark of Special Metals Corporation.

Type 1367

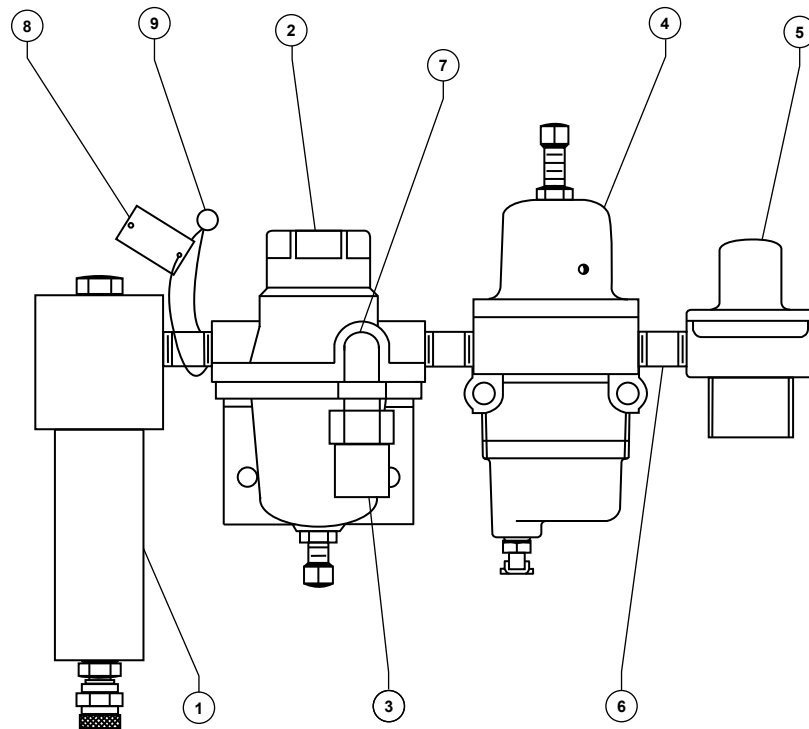

A7036

TYPE H120 RELIEF VALVE NOT SHOWN

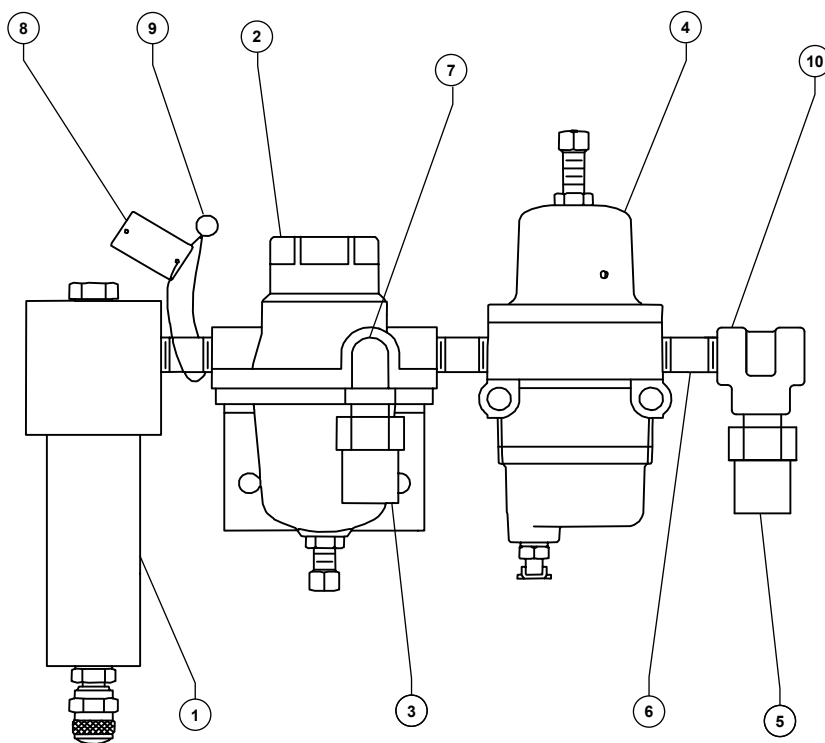

FIRST STAGE TYPE H120 RELIEF VALVE NOT SHOWN

Figure 3. Type 1367 Instrument Supply System Assembly

For Other Than Sour Gas Corrosion Resistance Applications

With Type H800

Key	Description	Part Number
1	Type 252 Filter	FS252-8 ⁽²⁾
2	Type 1301F Regulator	
	For yoke mounting	FS1301F-2/M1 ⁽²⁾
	For casing mounting	FS1301F-2/M3 ⁽²⁾
3	Type H120 Relief Valve	FSH120-150
4	Type 67CF Regulator	FS67CF-206 ⁽²⁾
5	Type H800 Relief Valve	FSH800-2 ⁽²⁾
6	Pipe Nipple, Zinc-plated	
	Galvanized steel (3 required)	-----
7	Street Elbow, Galvanized plated	
	Malleable iron	-----
8	Nameplate, Stainless steel (not shown)	-----
9	Wire, Monel [®] with Lead seal (not shown)	T12315T0012

With Type H120

Key	Description	Part Number
1	Type 252 Filter	FS252-4S
2	Type 1301F Regulator	
	For yoke mounting	FS1301F-N5/M1 ⁽²⁾
	For casing mounting	FS1301F-N5/M1 ⁽²⁾
3	Type H120 Relief Valve	FSH120-SS150
4	Type 67CFS Regulator	FS67CFS-226
5	Type H120 Relief Valve	FSH120-40
		FSH120-50
		FSH120-60
		FSH120-70
		FSH120-75
6	Pipe nipple, Stainless steel (3 required)	-----
7	Street Elbow, Stainless steel	-----
8	Nameplate, Stainless steel (not Shown)	-----
9	Wire, Monel [®] with lead seal (not shown)	-----
10	Pipe tee, Stainless steel	-----

2. For entire assembly. See separate manual for individual part numbers.

Monel[®] is a trademark of Special Metals Corporation.

Industrial Regulators

Emerson Process Management Regulator Technologies, Inc.

USA - Headquarters
McKinney, Texas 75069-1872, USA
Tel: +1 800 558 5853
Outside U.S. +1 972 548 3574

Asia-Pacific
Shanghai 201206, China
Tel: +86 21 2892 9000

Europe
Bologna 40013, Italy
Tel: +39 051 419 0611

Middle East and Africa
Dubai, United Arab Emirates
Tel: +971 4811 8100

Natural Gas Technologies

Emerson Process Management Regulator Technologies, Inc.

USA - Headquarters
McKinney, Texas 75069-1872, USA
Tel: +1 800 558 5853
Outside U.S. +1 972 548 3574

Asia-Pacific
Singapore 128461, Singapore
Tel: +65 6770 8337

Europe
Bologna 40013, Italy
Tel: +39 051 419 0611
Chartres 28008, France
Tel: +33 2 37 33 47 00

TESCOM

Emerson Process Management Tescom Corporation

USA - Headquarters
Elk River, Minnesota 55330-2445, USA
Tels: +1 763 241 3238
+1 800 447 1250

Europe
Selmsdorf 23923, Germany
Tel: +49 38823 31 287

Asia-Pacific
Shanghai 201206, China
Tel: +86 21 2892 9499

For further information visit www.fisherregulators.com

The Emerson logo is a trademark and service mark of Emerson Electric Co. All other marks are the property of their prospective owners. Fisher is a mark owned by Fisher Controls International LLC, a business of Emerson Process Management.

The contents of this publication are presented for informational purposes only, and while every effort has been made to ensure their accuracy, they are not to be construed as warranties or guarantees, express or implied, regarding the products or services described herein or their use or applicability. We reserve the right to modify or improve the designs or specifications of such products at any time without notice.

Emerson Process Management Regulator Technologies, Inc. does not assume responsibility for the selection, use or maintenance of any product. Responsibility for proper selection, use and maintenance of any Emerson Process Management Regulator Technologies, Inc. product remains solely with the purchaser.