

# Fisher® 480 Series Yokeless Piston Actuators

Fisher 480 Series actuators are yokeless piston actuators that are used in either throttling or on-off applications with ball valves, butterfly valves, louvers, dampers, and rheostats. They require pneumatic pressure loading from double-acting positioners (Fisher 3570) or from on-off loading and unloading devices.

## Features

- **Actuator Versatility**—Actuator with or without positioners and snubbers is available in an assortment of sizes, stroking speeds, thrusts, and travels to handle most control requirements.
- **Compact Design**—Yokeless construction permits a low-profile assembly by allowing close coupling to the control device; either through a bracket or, with some versions, by direct mounting on a bonnet flange.
- **Wide Range Supply Pressure Capability**—The cylinder (and 3570 positioner if used) can operate with supply pressures as low as 2.4 bar (35 psig) or as high as 10.3 bar (150 psig).
- **Long Stroke**—Actuators have maximum rated travels of up to 206 mm (8.125 inches).
- **Positioner Versatility**—Positioner/actuator action is easily reversed in the field with no additional parts. Positioner sensitivity, travel span, and travel starting point are factory set and need to be reset only if operating conditions have changed or if the positioner has been reversed. See figure 1.



W1867

Fisher 480-15 Piston Actuator

## Actuator Frequency Response

Figure 3 shows how various size actuators respond when the input supply pressure is cycled at small amplitude (3 to 5 percent) and increasing frequency.

Assume the cycling supply pressure and the movement of the actuator rod are represented by sine waves. As the actuator rod is forced to move faster, its motion begins to fall behind the input in both time (shown as phase lag) and amplitude (shown as normalized gain). Both of these parameters are affected by the inertia of the actuator and, consequently, changes are more pronounced in the larger constructions.



**480 Series Actuator Specifications**

**Available Configurations**

See the Actuator Configurations section

**Cylinder Pressure**

**Maximum Allowable:**<sup>(4)</sup> 10.3 bar (150 psig)  
**Required to Produce a Given Thrust:** See figure 2  
**Minimum Recommended:** Valves with low torque requirements - (2.4 bar [35 psig]); all other valves - (3.4 bar [50 psig])

**Maximum Supply Source Consumption**

**With Positioner and Constant Input Signal:** 0.54 normal m<sup>3</sup>/hr<sup>(1)</sup> (20 scfh<sup>(1)</sup>) of air at 6.9 bar (100 psig)  
**Without Positioner:** Depends on cylinder volume and supply pressure

**Travel Information**

**Maximum Rated Travels, All 480 Series actuators with Linear Output:** See table 1  
**Travel Stops Available for 480 Series actuators with 105 mm (4.125 inch ) Maximum Rated Travels:** See table 1

**Thrust Information**

See figure 2

**Torque Output**

**480, 480-15, and 480-16 (for butterfly valves):**  
 Contact your Emerson Process Management sales office

**Stroking Speeds**

See table 1

**Operative Ambient Temperature<sup>(2)</sup>**

**With Nitrile O-Rings:** -46 to 80°C (-50 to 175°F)  
**With Fluorocarbon O-Rings (Optional):<sup>(3)</sup>**  
 -18 to 149°C (0 to 300°F)

**Actuator Size and Piston Size**

See table 1

**Pressure Connections**

Standard is 1/4 NPT. For larger sizes, contact your Emerson Process Management sales office.

**Construction Materials**

**Actuator:**

Part	Material
Cylinder and Piston	Aluminum
Piston Rod Extension	SST, Chrome Plated
Cylinder Seal Bushings	Brass
O-Rings	Nitrile or Fluorocarbon

**Linkage Connections and Mounting Information**

See figures 7, 8, 9, and 10

**Options**

- 376 Series trip valve system to fail actuator
- up or ■ down or ■ lock in last position
- TopWorx™ DXP M21GNEB electrical valve stem position switch
- Micro-Switch limit switches

1. Normal m<sup>3</sup>/hr - normal cubic meters per hour (0°C and 1.01325 bar, absolute); Scfh - standard cubic feet per hour (60°F and 14.7 psia).  
 2. These terms are defined in ANSI/ISA Standard S51.1  
 3. Without snubber. If this actuator has a snubber, the temperature specification is the same for the nitrile version.  
 4. The pressure limits in this bulletin and any applicable standard or code limitation for actuator should not be exceeded.

**3570 Actuator Specifications**

**Available Configurations**

**3570:** Valve positioner with two relays and three pressure gauges for monitoring input signal and output pressures to the top and underside of the actuator piston  
**3570C:** Similar to 3570 except that the positioner is equipped with automotive tire valves instead of pressure gauges. The valves can be used for clip-on test pressure gauges. The relay nozzles on these positioners are locked in place with locknuts to resist unwanted nozzle movement due to vibration

**Input Signal**

**Standard Ranges:** 0.2 to 1.0 bar (3 to 15 psig) or 0.4 to 2.0 bar (6 to 30 psig)  
**Split Ranges:** Typically uses one half of standard range when two control valves are operated by one input signal from a single controller  
**Optional Ranges:** As required within the limits of the bellows

**Bellows Pressure Rating**

**Standard Bellows:** 3.4 bar (50 psig)  
**Optional Bellows:** 6.2 bar (90 psig)

**Supply Pressure**

**Maximum:** 10.3 bar (150 psig)  
**Minimum:** 2.4 bar (35 psig)

**Output Signal**

**Type:** Pneumatic pressure as required by the actuator  
**Action:** Field reversible between direct and reverse (see table 2)

**Hysteresis<sup>(1,2)</sup>**

0.15% of total stroke or instrument pressure span

**Resolution<sup>(1,2)</sup>**

0.2% of instrument pressure span

**Repeatability<sup>(1,2)</sup>**

0.3% of instrument pressure span

**Frequency Response<sup>(1,2)</sup>**

See figure 3

**Pressure Connections**

**Vent:** 3/8 NPT  
**All Others:** 1/4 NPT

**Pressure Indications**

**3570C:** Tire valves accept standard pressure gauge chucks  
**3570:** See table below

Type of Indication	Number Used	Standard Gauge Range bar (psig)
Positioner input signal gauge	1	0 to 2.1 (0 to 30) or 0 to 4.1 (0 to 60)
Cylinder supply pressure gauge	0	0 to 11.0 (0 to 160)

**Static Air Consumption<sup>(3)</sup>**

0.56 normal m<sup>3</sup>/hr (20 scfh) with 6.9 bar (100 psig) supply pressure

**Operative Ambient Temperature<sup>(1,2)</sup>**

**With Nitrile O-Rings:** -34 to 79°C (-30 to 175°F)  
**With Fluorocarbon O-Rings (Optional):<sup>(3)</sup>** -18 to 149°C (0 to 300°F)

**Construction Materials**

**Actuator:**

Part	Material
Base, Cover and Beam	Aluminum, die cast
Bellows	Brass
Bias and Range Spring	Steel, Plated
Relay Body	Zinc, Die Cast
Relay Nozzle(s)	SST
Diaphragm	Nitrile or Fluorocarbon
O-Rings	Nitrile or Fluorocarbon

**Options**

Fisher SS-52 clip-on chuck (with or without gauge) for 3570C positioners

1. These terms are defined in ANSI/ISA Standard S51.1  
 2. For actuator with positioner only. Does not apply to other constructions or actuator-valve combination.  
 3. Normal m<sup>3</sup>/hr.- normal cubic meters per hour (0°C and 1.01325 bar, absolute); Scfh - standard cubic feet per hour (60°F and 14.7 psia).

**Table 1. Size, Piston, Stroking Speed, and Travel Information**

ACTUATOR SIZE	EFFECTIVE PISTON AREA		PISTON DIAMETER		STROKING SPEED <sup>(1)</sup>		SINGLE-FLANGE				TRAVEL STOPS AVAILABLE FOR ACTUATORS WITH 105 mm (4.125 INCHES) MAXIMUM RATED TRAVEL	
	cm <sup>2</sup>	Inch <sup>2</sup>	mm	Inch	mm/s	Inch/s	-16 Versions		All Others Except Fisher 487, 487-1 <sup>(2)</sup>		mm	Inch
							mm	Inch	mm	Inch		
30	107	16.5	121	4.75	102	4	---	---	105	4.125	89	3.5
40	182	28.25	156	6.125	52	2.05	206	8.125	105	4.125	89	3.5
60	258	55.5	216	8.5	33	1.30						

1. For actuators with positioners at 6.9 bar (100 psig) supply pressure and all prestroke conditions satisfied. Stroking speeds for actuators without positioners or with snubbers will depend on the particular construction involved.  
2. See 480 Series Actuators Specifications for these travels.

**Table 2. Action Under Normal Operating Conditions**

ACTUATOR DESCRIPTION		DESIRED PISTON MOTION	
		Down	Up
With Positioner	Direct-acting	Increasing input signal pressure to bellows <sup>(1)</sup>	Decreasing input signal pressure to bellows <sup>(1)</sup>
	Reverse-acting	Decreasing input signal pressure to bellows <sup>(1)</sup>	Increasing input signal pressure to bellows <sup>(1)</sup>
Without positioner		Supply pressure loaded on top of piston, exhausted from bottom	Supply pressure loaded on bottom of piston, exhausted from top

1. Supply pressure is routed through relays to piston.

**Figure 1. Positioner Simplicity**

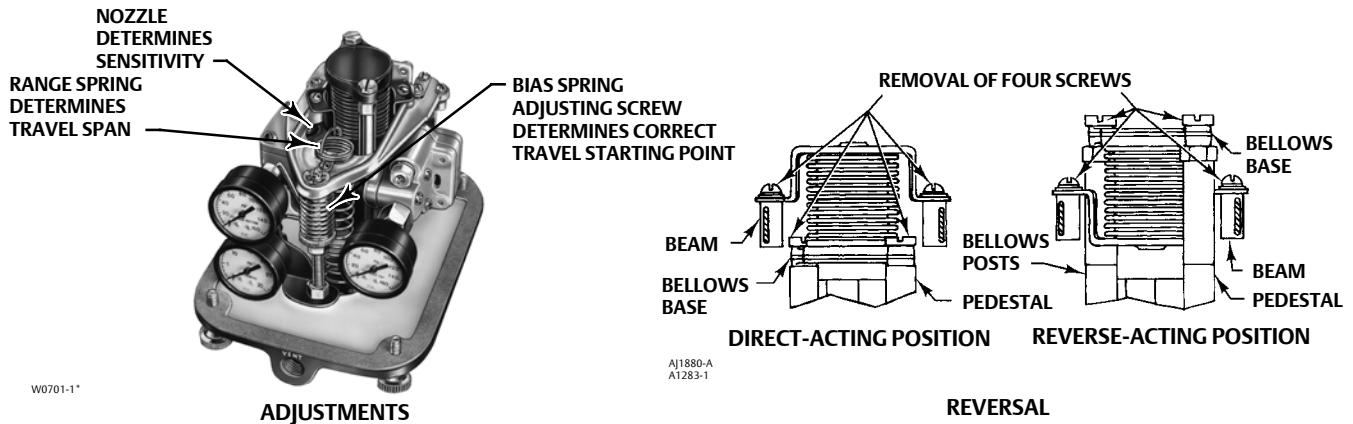

## Actuator Configurations

**480:** Yokeless piston actuator with positioner.

**481:** Yokeless piston actuator without positioner. Other actuators may be obtained without positioner by adding -1 to the type number.

The above actuators come with standard mounting flange, 105 mm (4.125 inch) maximum rated travel, and threaded piston rod connection with sizes 30 through 60 for mounting on ball valves, louvers, and dampers with brackets.

These actuators may be obtained with the following alternate universal mounting flange constructions:

**-15 Added to Type Number:** Allows butterfly valve mounting for a standard actuator with 105 mm (4.125 inch) maximum travel and threaded piston rod connection, and comes in sizes 30 through 60.

**-16 Added to Type Number:** Provides 206 mm (8.125 inch) maximum travel and threaded piston rod connection, and comes in sizes 40 through 60.

**Figure 2. Supply Pressure and Thrusts**

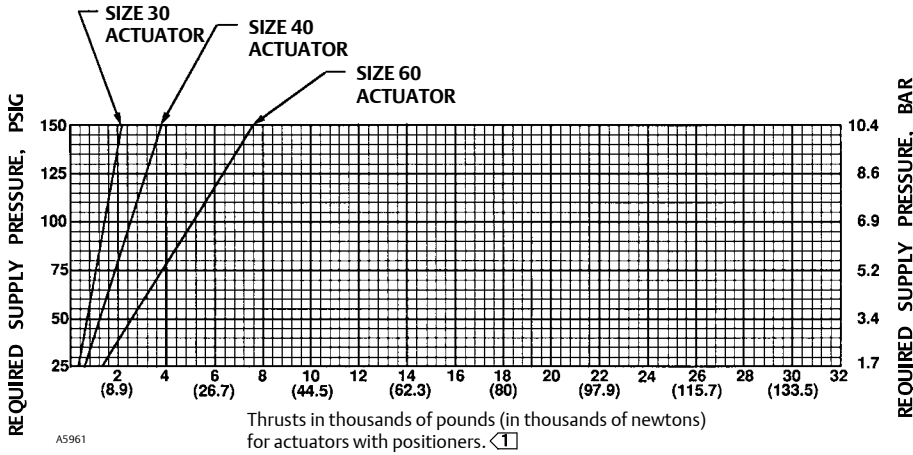

Note:

① May be increased by 10% for actuators without positioners. Either this thrust, or the maximum allowable loading for the control device is the limiting factor for usable actuator force.

**Figure 3. Frequency Response**

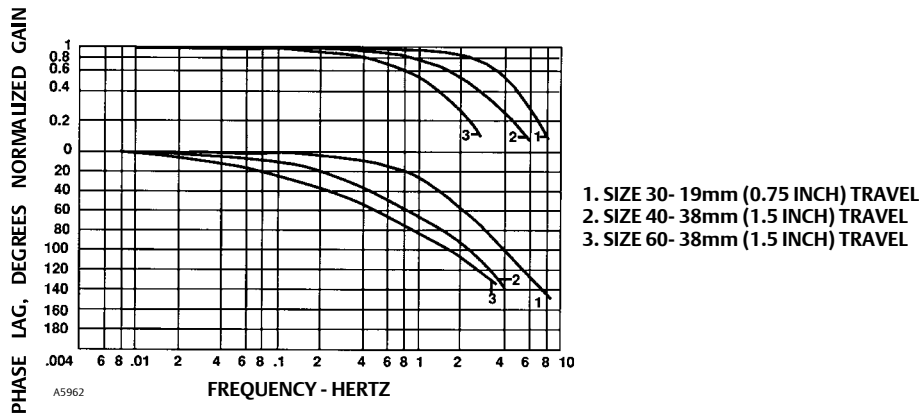

# Principle of Operation

## Actuator

These actuators react to a pressure unbalance that is created by loading supply pressure on one side of the piston and unloading the opposite side. Some type of switching device is required to shift the supply pressure from one side of the piston to the other. For most actuators in the 480 Series, this device is a 3570

positioner. However, a separate loading device must be provided for actuators without positioners.

For actuators with positioners (figure 4), the pneumatic output signal from a controller or instrument is piped to the positioner bellows. As long as the bellows receives a constant input signal pressure, the beam remains motionless and allows supply pressure to bleed through both relay nozzles such that a constant pressure is maintained between the nozzle and the fixed orifice. The relays are in equilibrium with their inlet and exhaust valves closed.

Figure 4. Operation of Actuator with Positioner

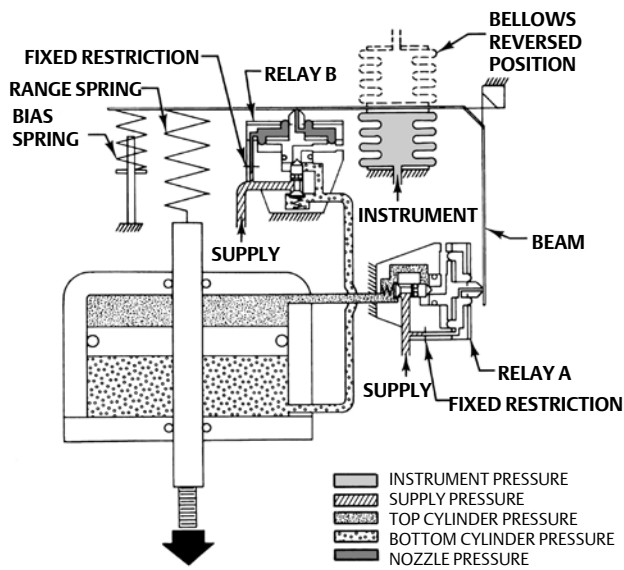

Assume that a downward piston motion is required and the bellows receives a corresponding change in input signal pressure. This causes the beam to pivot so that it covers the nozzle on relay A. (Beam movement is accomplished either by increasing the input signal pressure on a direct-acting positioner to expand the bellows, or by decreasing the input signal pressure on a reverse-acting positioner to contract the bellows.)

The nozzle pressure in relay A increases due to the restriction created by the beam over the nozzle. Through relay action, the air pressure to the top of the piston is increased. At the same time, relay B reacts to the change in beam position to decrease the pressure to the underside of the piston. Due to the resulting unbalanced forces acting on the piston, it moves down, changing the valve plug position.

Piston movement is fed back to the beam by means of a range spring which is connected to the beam and to the piston rod extension, applying a force to the beam opposite to that caused by the expanding or contracting bellows. This feedback arrangement prevents overcorrection and ensures a definite position of the piston and valve plug for a given instrument signal.

Figure 5. Operation of Actuator with Snubber

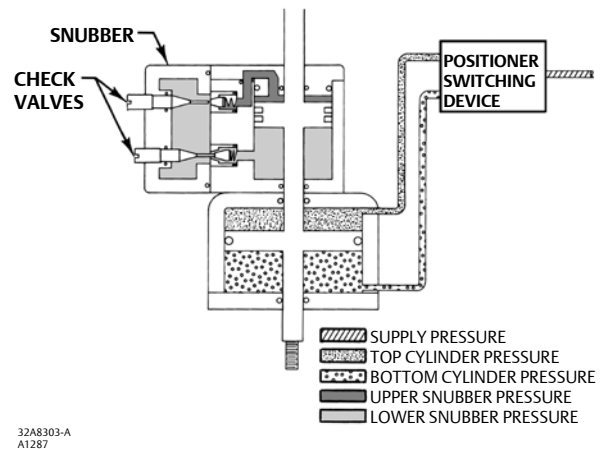

If upward piston motion is required, the beam pivots over the nozzle on relay B. The result is relay, piston, and feedback action opposite that for downward piston motion.

Reversal of positioner action is accomplished simply by removing four screws, inverting the bellows, and installing two bellows posts for support if the change is from direct to reverse action. Bellows posts are stored in the positioner case and are not used if the change is from reverse to direct.

## Actuator with Snubber

As the actuator piston strokes, the snubber piston moves inside an oil-filled cylinder, forcing oil from one side of the piston to the other through two check valves (see figure 5). The resistance to flow created by the settings of the check valves and the shock absorbing quality of the oil combine to damp out any tendency of the valve plug to jump. The plug of each check valve is held off its seat by the positioning of the adjusting screws. Thus, with the adjusting screws backed off all the way, maximum damping will be obtained.

## Installation

The actuator may be installed in any position, but normal installation is with the actuator vertical above the valve. Dimensions are given in figures 6, 7, 8, 9, and 10.

## Ordering Information

When ordering, specify:

1. Type number
  - a. For actuator, suffix dash numbers of desired constructions are appropriate.
  - b. For positioner (if used)
2. Supply Pressure
3. Actuator size and connection size and style desired
4. Input signal range
5. Desired stroking time and direction, if applicable
6. Operative ambient temperature
7. Travel
8. Desired options
9. Application requirements
  - a. Type, body size, port diameter, stem connection size, and the action of the valve to be used with the actuator.
  - b. Valve inlet pressure
  - c. Valve shutoff pressure drop
  - d. Valve flowing pressure drop
  - e. Process fluid temperature

**Table 3. Cylinder Diameter and Bolt Center Location, All Actuators**

ACTUATOR SIZE	C		H, DEGREE OF ARC	
	mm	Inch	Standard Flange	Universal Mounting Flange
30	171	6.75	0	45
40	206	8.12	45	45
60	267	10.50	22.5	45

**Figure 6. Cylinder Diameter and Bolt Center Location, All Actuators (refer to table 3)**

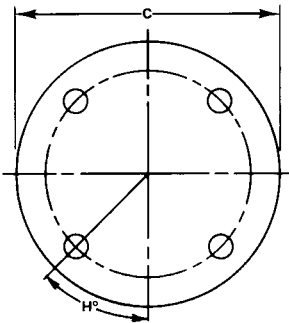

BH9452-K  
A1290

**Figure 7. Dimensions for Actuators with Clevis Connection**

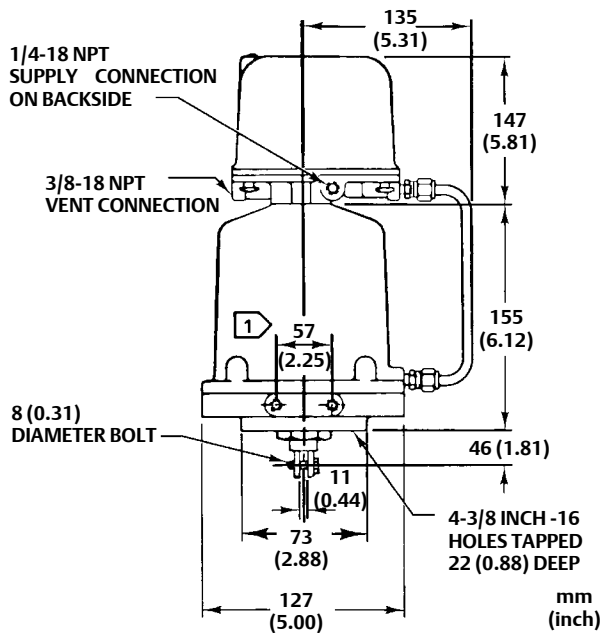

BK4109-B  
A1295

1 Duplicated on opposite side; each hole is 5/16 inch-18 UNC-2B and tapped 13 (0.50) deep.



**Table 4. Dimensions and Mounting Information for Actuators with Threaded Piston Rod and Standard Mounting Flange, or Positioner, or Snubber**

ACTUATOR SIZE	A		B		D		F		G		Number	I		K THREADED PISTON ROD CONNECTION UNF-2A
	mm	Inch	mm	Inch	mm	Inch	mm	Inch	mm	Inch		Bolt Circle Diameter		
												mm	Inch	
30	250	8.06	86	3.38	170	6.69	63	2.50	33	1.31	2	146	5.75	7/8 inch - 14
40	208	8.19	83	3.25	173	6.81	63	2.50	33	1.31	4	181	7.12	
60	211	8.31	79	3.12	203	8.00	63	2.50	33	1.31	8	241	9.50	

**Figure 8. Dimensions and Mounting Information for Actuators with Threaded Piston Rod and Standard Mounting Flange, or Positioner, or Snubber (refer to table 4)**

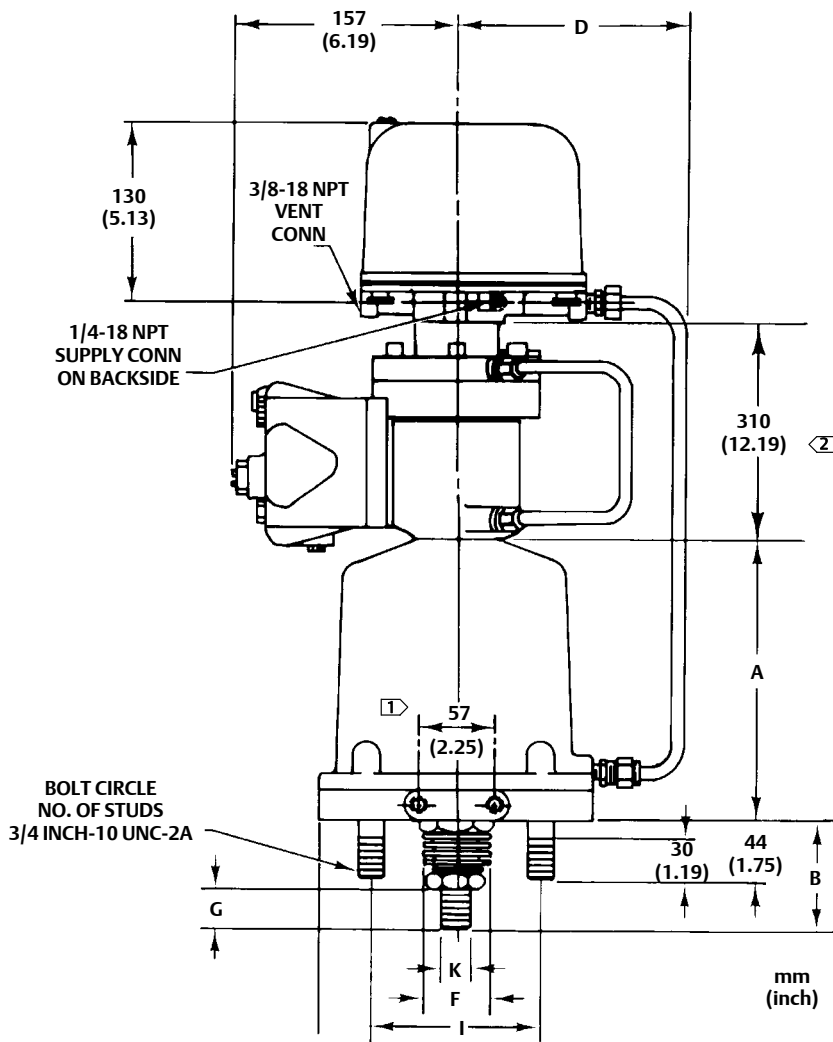

BL1413-B  
A1291

① Duplicated on opposite side; each hole is 5/16 inch-18 UNC-2B and tapped 13 (0.50) deep.  
② This dimension does not exist if no snubber is used.

Table 5. Dimensions for Actuators without Positioner, with Long Stroke, or with Threaded Piston Rod and Universal Mounting Flange

Actuator Size	A				B				F				G				I		K	
	-15 Versions		-16 Versions		-15 Versions		-16 Versions		-15 Versions		-16 Versions		-15 Versions		-16 Versions		Bolt Circle Diameter	Thread Diameter	Threaded Piston Rod Connection UNF-2A	
	mm	Inch	mm	Inch	mm	Inch	mm	Inch	mm	Inch	mm	Inch	mm	Inch	mm	Inch				
30	222	8.75	--	--	90	3.56	--	--	64	2.5	--	--	33	1.31	--	--	99	3.88	1/2-13	7/8-inch-14
40, 60	222	8.75	343	13.5	90	3.56	108	4.25	64	2.5	47	1.87	33	1.31	51	2.00	99	3.88	1/2-13	7/8-inch-14

Figure 9. Dimensions for Actuators without Positioner, with Long Stroke, or with Threaded Piston Rod and Universal Mounting Flange (refer to table 5)

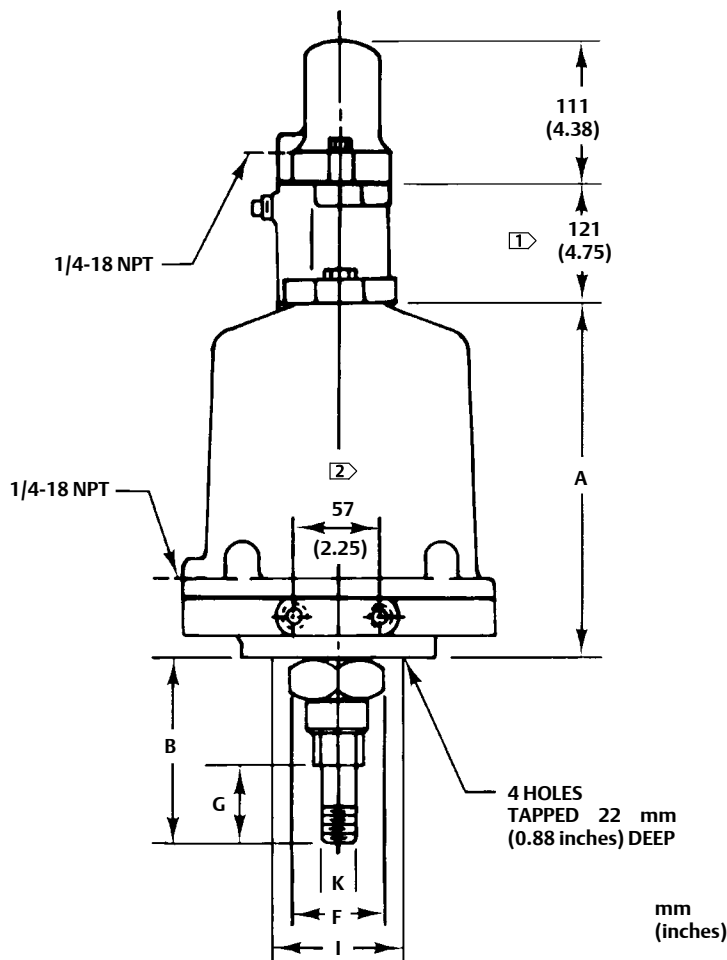

① For -16 version only.  
② Duplicated on opposite side; each hole is 5/16 inch-18 UNC-2B and tapped 13 mm (0.50 inches) deep.

Figure 10. Dimensions for Actuators with Rotary Couplings

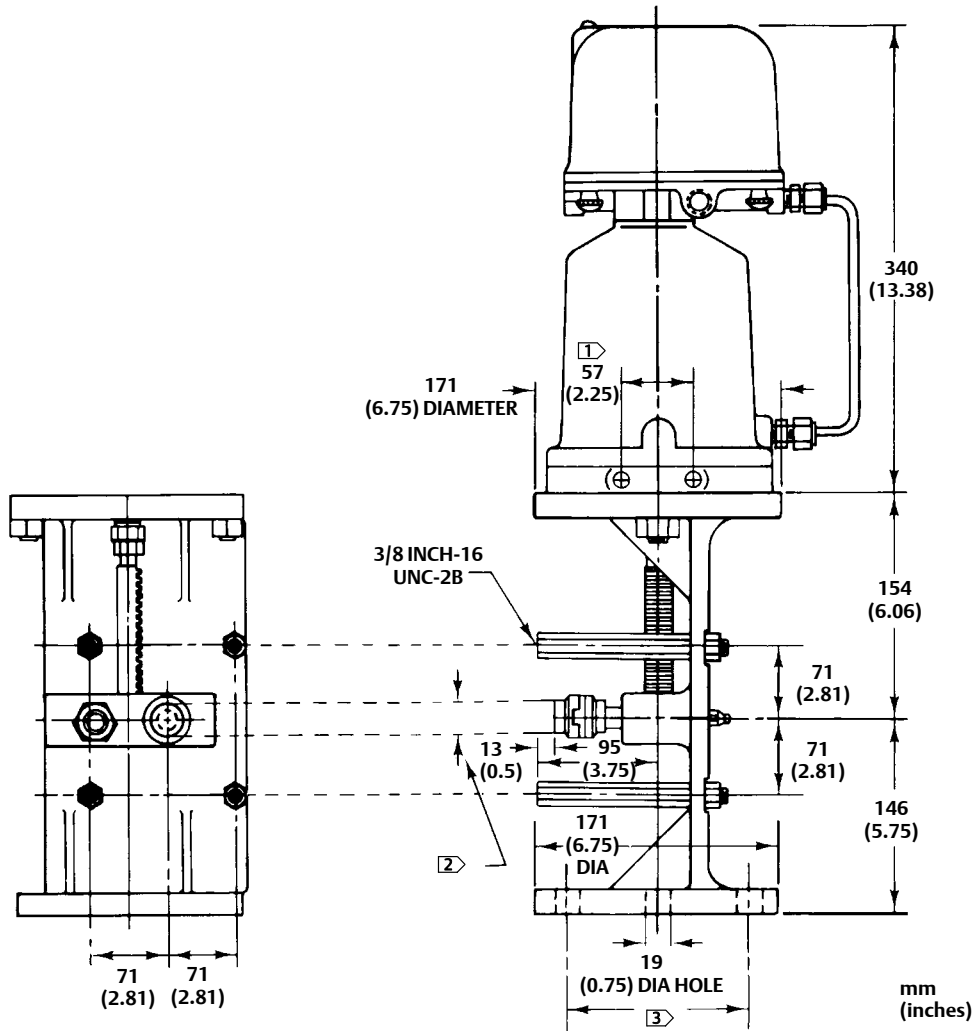

BK6785-B  
B0662

- ① Duplicated on opposite side; each hole is 5/16 inch-18 UNC-2B and tapped 13 mm (0.50 inches) deep.
- ② Socketed coupling with setscrew adjustment. 6 mm (0.25 inch), 10 mm (0.38 inch), and 13 mm (0.50 inch) inside diameters.
- ③ Four holes total on 140 mm (5.5 inch) bolt circle.

**Neither Emerson, Emerson Process Management, nor any of their affiliated entities assumes responsibility for the selection, use or maintenance of any product. Responsibility for proper selection, use, and maintenance of any product remains solely with the purchaser and end user.**

Fisher and TopWorx are marks owned by one of the companies in the Emerson Process Management business unit of Emerson Electric Co. Emerson Process Management, Emerson, and the Emerson logo are trademarks and service marks of Emerson Electric Co. All other marks are the property of their respective owners.

The contents of this publication are presented for informational purposes only, and while every effort has been made to ensure their accuracy, they are not to be construed as warranties or guarantees, express or implied, regarding the products or services described herein or their use or applicability. All sales are governed by our terms and conditions, which are available upon request. We reserve the right to modify or improve the designs or specifications of such products at any time without notice.

**Emerson Process Management**

Marshalltown, Iowa 50158 USA  
Sorocaba, 18087 Brazil  
Chatham, Kent ME4 4QZ UK  
Dubai, United Arab Emirates  
Singapore 128461 Singapore

[www.Fisher.com](http://www.Fisher.com)