

Type R632A Integral Two-Stage Regulator

Introduction

The Type R632A is an Underwriters Laboratories (UL®) listed regulator designed for Two-Stage LP-Gas systems. The unit is designed to reduce the tank pressure through an integral two-stage system to 11 inches w.c. / 27.4 mbar. The first-stage screened drip-lip vent is oriented downward and the second-stage vent is oriented over the outlet as standard.



Figure 1. Type R632A Integral Two-Stage Regulator

Features

- 20-Year Recommended Replacement Life –**
 The Type R632A is designed using rugged time proven design concepts with enhancements to the corrosion resistance and durability of materials, both internally and externally. With proper installation and periodic inspection and maintenance the Type R632A design has a 20-Year Recommended Replacement Life. In some environmental conditions earlier replacement may be required.
- Improved Regulations –** Fisher®'s large molded fabric reinforced diaphragm and spring assisted vent stabilizer deliver accurate, stable regulation.
- Superior Overpressure Protection –**
 The combination of a high capacity relief valve and large vent provide overpressure protection which exceeds UL standards.
- Easy System Checks –** Intermediate and outlet 1/8-inch NPT inlet and outlet gauge taps orifice to a number 54 drill size for easy gas system checks.
- Corrosion-Resistant –** Added corrosion resistance with an internal and external coating process for all castings prior to painting, stainless steel relief valve spring and retainer and a non-corrosive relief valve seat.
- Positive Drainage –** When installed properly with the spring case pointed down the Fisher Positive Drainage design allows any moisture formed in the spring case to drain out eliminating the problems with corrosion and freezing of the water in the spring case.

Table 1. Selected Capacities for Type R632A Integral Two-Stage Regulators

OUTLET PRESSURE SETTING, SPRING RANGE	INLET PRESSURE		CAPACITIES IN THOUSANDS BTU/HR PROPANE ⁽¹⁾	
	psig	bar	1/2 Outlet	3/4 Outlet
11 inches w.c. / 27.4 mbar setting, 9 to 13 inches w.c. / 22.4 to 32.4 mbar spring range	25	1.7	750	780
	30	2.1	850	850
	100	6.9	1080	1330
	250	17.2	1230	1700

1. Capacities are based on 2 inches w.c. / 5.0 mbar droop.



Bulletin LP-7: R632A

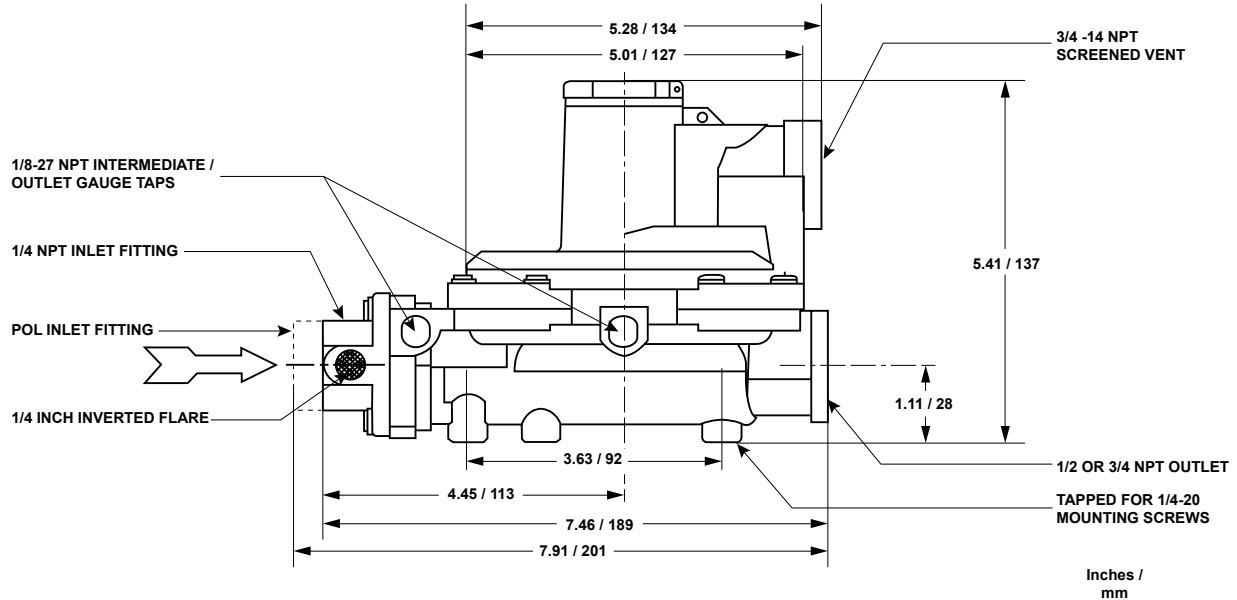

Figure 2. Type R632A Dimensions

Table 2. Ordering Information

TYPE NUMBER	CAPACITY BTU/HR PROPANE ⁽¹⁾	CONNECTIONS INLET X OUTLET	OUTLET ADJUSTMENT SETTING	OUTLET PRESSURE RANGE
R632A-BCF	850,000	1/4 inch x 1/2 inch FNPT	11 inches w.c. / 27.4 mbar	9 to 13 inches w.c. / 22.4 to 32.4 mbar
R632A-BCFXA ⁽²⁾				
R632A-HCF		FPOL x 1/2 inch FNPT		
R632A-HCFXA ⁽²⁾				
R632A-CFF	950,000	1/4 inch x 3/4 inch FNPT		
R632A-CFFXA ⁽²⁾				
R632A-JFF	850,000	FPOL x 3/4 inch FNPT		
R632A-JFFXA ⁽²⁾				

1. Capacities are based on 30 psig / 2.07 bar inlet pressure and 2 inches w.c. / 5.0 mbar droop.
 2. First and second stage spring case vents opposite gauge taps.

LP-Gas Equipment

Emerson Process Management Regulator Technologies, Inc.

USA - Headquarters
 McKinney, Texas 75069-1872, USA
 Tel: +1 800 558 5853
 Outside U.S. +1 972 548 3574

For further information visit www.fisherregulators.com

The Emerson logo is a trademark and service mark of Emerson Electric Co. All other marks are the property of their prospective owners. Fisher is a mark owned by Fisher Controls International LLC, a business of Emerson Process Management.

The contents of this publication are presented for informational purposes only, and while every effort has been made to ensure their accuracy, they are not to be construed as warranties or guarantees, express or implied, regarding the products or services described herein or their use or applicability. We reserve the right to modify or improve the designs or specifications of such products at any time without notice.

Emerson Process Management Regulator Technologies, Inc. does not assume responsibility for the selection, use or maintenance of any product. Responsibility for proper selection, use and maintenance of any Emerson Process Management Regulator Technologies, Inc. product remains solely with the purchaser.