

Fisher® 1069 Dual Piston Pneumatic Rotary Actuator

Contents

Introduction	1
Scope of Manual	1
Description	1
Specifications	2
Installation	2
Actuator Mounting	3
Loading Connections	6
Adjustment	7
Principle of Operation	8
Maintenance	8
Disassembly	9
Assembly	10
Manual Operator	12
Installation	12
Engaging and Disengaging the Manual Operator ..	12
Operation	13
Parts Ordering	13
Parts List	14

Figure 1. Fisher 1069 Actuator



W4037-1

Introduction

Scope of Manual

This instruction manual includes installation, adjustment, maintenance, and parts ordering information for the Fisher 1069 dual piston pneumatic rotary actuator (see figure 1). Instructions for the control valve body, the valve positioner, and accessories are included in separate instruction manuals.

Description

The 1069 dual piston pneumatic rotary actuator is for use with larger sizes of rotary shaft valves such as NPS 16 through 24 V250 ball valves and NPS 30 and 36 8510 eccentric disk valves. The 1069 actuator can be used for throttling service when equipped with a valve positioner, or for on-off service when equipped with switching devices.



Table 1. Specifications

<p>Available Configuration</p> <p>Dual piston pneumatic rotary actuator for</p> <ul style="list-style-type: none"> ■ throttling service when used with positioner or ■ on-off service when used with switching devices <p>Actuator Size</p> <p>Size 100: Contains two 330 mm (13-inch) diameter pistons</p> <p>Cylinder Operating Pressure</p> <p>Minimum Recommended: ■ 2.4 bar (35 psig) without positioner or ■ 3.4 bar (50 psig) with positioner⁽¹⁾</p> <p>Maximum Allowable: 10.3 bar (150 psig)</p> <p>Acceptable Valve Shaft Diameters</p> <ul style="list-style-type: none"> ■ 76 mm (3 inches) and ■ 89 mm (3-1/2 inches) <p>Maximum Valve Shaft Rotation</p> <ul style="list-style-type: none"> ■ 90 degrees (standard) or ■ 60 degrees (optional) <p>Maximum Breakout Torque of Actuator</p> <p>29700 N•m (263,000 inch-pounds)</p> <p>Maximum Output Torque of Manual Operator</p> <p>32,000 N•m (283,200 inch-pounds)</p> <p>Maximum Allowable Input Torque of Manual Operator</p> <p>201 N•m (1776 inch-pounds)</p>	<p>Stroking Time</p> <p>Dependent on actuator rotation and positioner if used. If stroking time is critical, consult your Emerson Process Management sales office</p> <p>Material Temperature Capabilities with Standard Elastomers</p> <p>-29 to 82°C (-20 to 180°F)</p> <p>Pressure Connections</p> <ul style="list-style-type: none"> ■ 1/4 NPT internal and ■ 3/4 NPT internal <p>Displacement for 90 Degrees Rotation</p> <p>0.06 m³ (2.13 cubic feet)</p> <p>Travel Indication</p> <p>Graduated scale and pointer located on actuator end of valve shaft</p> <p>Mounting Positions</p> <p>Either right or left-hand mounted as viewed from the valve inlet in any of the four positions shown in figure 2</p> <p>Approximate Weight</p> <p>Actuator: 567 kg (1250 pounds)</p> <p>Manual Operator: 324 kg (715 pounds)</p>
---------------------------------------------------------------------------------------------------------------------------------------------------------------------------------------------------------------------------------------------------------------------------------------------------------------------------------------------------------------------------------------------------------------------------------------------------------------------------------------------------------------------------------------------------------------------------------------------------------------------------------------------------------------------------------------------------------------------------------------------------------------------------------------------------------------------------------------------------------------------------------------------------------------------------------------------------------------------------------------------------------------------------------------------------------------------------------------------------------------------------------------------------------------------------------	--------------------------------------------------------------------------------------------------------------------------------------------------------------------------------------------------------------------------------------------------------------------------------------------------------------------------------------------------------------------------------------------------------------------------------------------------------------------------------------------------------------------------------------------------------------------------------------------------------------------------------------------------------------------------------------------------------------------------------------------------------------------------------------------------------------------------------------------------------------------------------------------------------------------------

1. See separate instruction manual for positioner specifications.

Do not install, operate, or maintain a 1069 actuator without being fully trained and qualified in valve, actuator, and accessory installation, operation, and maintenance. To avoid personal injury or property damage, it is important to carefully read, understand, and follow all the contents of this manual, including all safety cautions and warnings. If you have any questions about these instructions, contact your Emerson Process Management sales office before proceeding.

Specifications

Specifications for 1069 actuators are shown in table 1. Specifications for a given actuator, and manual operator if used, as it originally comes from the factory, are stamped on a nameplate (key 32, figure 4) attached to the actuator.

Installation

When an actuator and valve body are shipped together, the actuator is normally mounted on the valve body. Follow the valve body instructions when installing the control valve in the pipeline. If it is necessary to mount the actuator on

the valve body, or if it is necessary to change actuator mounting positions, perform the actuator mounting procedures.

▲ WARNING

To avoid personal injury or property damage caused by bursting of pressure-retaining parts, be certain the cylinder pressure does not exceed the cylinder pressure limits listed in table 1. Use pressure-limiting or pressure-relieving devices to prevent the cylinder pressure from exceeding these limits.

Always wear protective gloves, clothing, and eyewear when performing any installation operations to avoid personal injury.

Check with your process or safety engineer for any additional measures that must be taken to protect against process media.

If installing into an existing application, also refer to the WARNING at the beginning of the Maintenance section in this instruction manual.

Actuator Mounting

Use the following steps to connect a valve body and actuator that have been ordered separately. This procedure can also be performed to change actuator mounting positions. Key numbers used in this procedure are shown in figure 4.

CAUTION

To avoid possible damage to the travel stop screws (key 35 and, if used, key 9), make sure the travel stop screws are turned all the way into the housing (key 15) before setting the housing on its support legs.

1. Remove the cap screws and washers (keys 25 and 38) and then remove the cover (key 24). If a manual operator is used, it is removed with the cover.
2. Remove the cap screws and anti-rotator assemblies (keys 8 and 42).
3. If the lever (key 19) is attached to the valve shaft, loosen the cap screws (key 20) and rotate the set screw (key 41) clockwise slightly to spread the split portion of the lever. Then, remove the lever through the openings in the housing (key 15). For an 8510 valve body, the disk must be open approximately 20 degrees to allow enough clearance for lever removal. For a V250 valve body, the ball must be open approximately 70 degrees to allow enough clearance for lever removal. Consult the valve body instruction manual for assistance during this step.

CAUTION

Do not use a hammer or similar tool to drive the lever (key 19) off the valve shaft. Driving the lever could damage internal valve parts. On some valve bodies, driving the lever could move the valve disk and bearings away from the centered position, causing subsequent damage to valve parts as the valve is operated.

If necessary, use a wheel puller to remove the lever. It is okay to tap the wheel puller screw lightly to loosen the lever, but hitting the screw with excessive force could also damage valve parts or disrupt the centered position of the valve disk and bearings.

4. If the housing was removed from the mounting yoke (key 17), secure it to the mounting yoke with the cap screws (key 18).
5. Consult figure 2 for available mounting positions. The actuator is normally positioned vertically with the valve body in a horizontal pipeline. If changing actuator mounting positions, unscrew the cap screws (key 18) and rotate the housing (key 15) to the desired position.

Figure 2. Mounting Positions

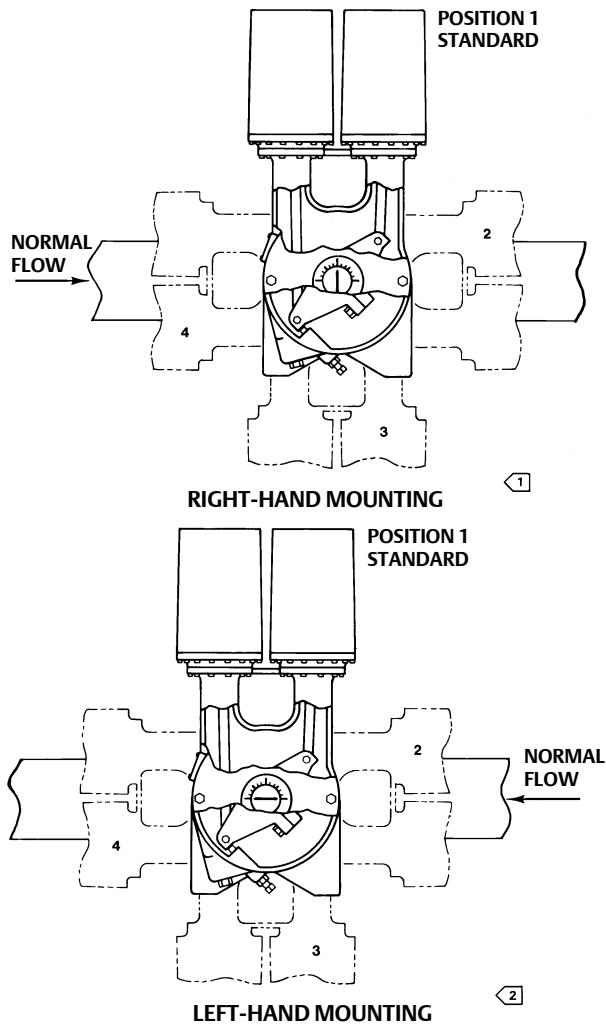

NOTES:

- 1 ⤴ CLOCKWISE-TO-OPEN ACTION FOR V250 VALVES,
CLOCKWISE-TO-CLOSE ACTION FOR 8510 VALVES
- 2 ⤴ CLOCKWISE-TO-CLOSE ACTION FOR V250 AND 8510 VALVES

49A3300-A
B1808

Figure 3. Lever Operating Clearances

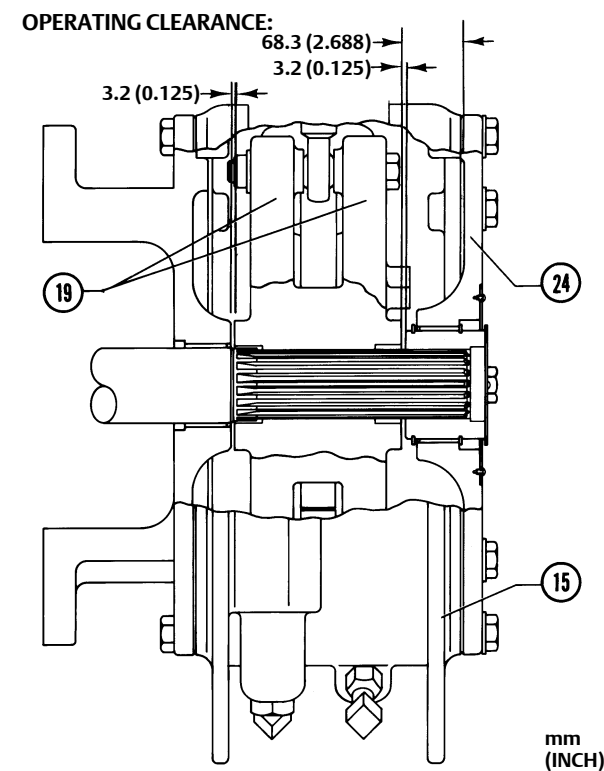

6. If the actuator and valve body are separated, mount the actuator on the valve body with the valve body cap screws. When mounting the actuator, make sure that the bearing (key 40) and valve shaft are in line so that the bearing will slide onto the valve shaft without being damaged. Refer to the appropriate valve body instruction manual for bolting torques for the cap screws.

CAUTION

Refer to table 2 for actuator bolt torque requirements. Exceeding any torque requirement could damage actuator parts and impair safe operation.

7. To aid installation of the lever, apply lithium grease (key 45) to the exposed valve shaft spline. It may be necessary to rotate the set screw (key 41) clockwise slightly to spread the split portion of the lever and allow installation onto the valve shaft.
8. Consult the appropriate valve body instruction manual for lever/valve shaft orientation marks and slide the lever into place. Consult figure 3 for the appropriate lever operating clearances. When the lever is in place, back off the set screw (key 41) so that the lever can be clamped onto the valve shaft. Secure the assembly with the cap screws (key 20).
9. Rotate the lever until both cap screw holes are aligned with both rod end bearings (key 7).
10. Connect the lever to each rod end bearing with a cap screw and anti-rotator assembly (keys 8 and 42). Cap screw torques are listed in table 2.

Table 2. Bolting Torques

KEY NUMBER	BOLTING TORQUE	
	N•m	Foot-Pounds
3	102	75
8	407	300
16	102	75
18	542	400
20	271	200
25	542	400
43	678	500

11. Note the valve disk or ball position and direction of rotation.
 - a. If a manual operator is not used, position the travel indicator and hub (keys 28 and 21) according to the valve disk or ball position just noted. Replace the cover (key 24), and secure it with the washers and cap screws (keys 38 and 25). Do not stroke the actuator past the fully open or closed position while the cover is off.
 - b. If a manual operator is used, refer to the manual operator section of this instruction manual.
12. When the 1069 actuator is equipped with an auxiliary manual operator, make certain that a bypass valve (key 53) is installed and used to equalize cylinder pressure during handwheel operation. Operating the manual operator by itself against the force of differential cylinder pressures will be difficult or even impossible.

CAUTION

Attempting to operate the 1069 actuator when the auxiliary manual operator is engaged could damage the splined valve shaft. Be certain the manual operator is disengaged before operating the 1069 actuator.

13. Perform the adjustment procedures before proceeding to the loading connection procedure.

Loading Connections

1. If a valve positioner is used with the control valve, the pressure connections to the actuator are normally made at the factory. Actuators without positioners should have either a four-way solenoid valve or a switching valve connected to the 1/4 NPT or 3/4 NPT pressure connections located at the top and bottom of both actuator cylinders.
2. Connect either 19 mm (3/4-inch) hose or 9.5 mm (3/8-inch) tubing between the actuator pressure connections and a controlling instrument. Keep the length of hose or tubing as short as possible to avoid transmission lag in the control signal.
3. When the control valve is completely installed and connected to the controlling instrument, check for correct action (clockwise-to-open or clockwise-to-close) to match the controlling instrument. For successful operation, the actuator stems and valve shaft must move freely in response to the loading pressure changes on the pistons.

Adjustment

⚠ WARNING

Avoid personal injury or property damage from sudden release of process fluid. Before starting adjustment:

- Do not remove the actuator from the valve while the valve is still pressurized.
 - Always wear protective gloves, clothing, and eyewear when performing any maintenance operations to avoid personal injury.
 - Disconnect any operating lines providing air pressure, electric power, or a control signal to the actuator. Be sure the actuator cannot suddenly open or close the valve.
 - Use bypass valves or completely shut off the process to isolate the valve from process pressure. Relieve process pressure on both sides of the valve. Drain the process media from both sides of the valve.
 - Vent the power actuator loading pressure and relieve any actuator spring precompression.
 - Use lock-out procedures to be sure that the above measures stay in effect while you work on the equipment.
 - The valve packing box may contain process fluids that are pressurized, *even when the valve has been removed from the pipeline*. Process fluids may spray out under pressure when removing the packing hardware or packing rings, or when loosening the packing box pipe plug.
 - Check with your process or safety engineer for any additional measures that must be taken to protect against process media.
-

The only adjustment on the 1069 actuator is to make sure the valve disk or ball is correctly opened or closed when the lever (key 19, figure 4) is positioned against either of the travel stops. For accurate adjustment of the zero-degree position of the valve disk or ball, the control valve must be removed from the pipeline. Refer to the valve body instruction manual for instructions during this procedure.

If the actuator is equipped with a manual operator, make sure that the manual operator is in the disengaged position and that the bypass valve (key 53) is closed before performing adjustment procedures.

To adjust the 1069 actuator, perform the following steps. A regulated air supply is required to stroke the actuator during this procedure. Key numbers referenced in this procedure are shown in figure 4.

Note

When shipped, the 1069 actuator is equipped as specified for either 60-degree or 90-degree valve shaft rotation. For 60-degree rotation, the travel stop screw (key 9), travel stop nut (key 34), hex nut (key 37), and cap screw (key 46) must be installed as shown in figure 4. For 90-degree rotation, two travel stop screws (key 35) and two hex nuts (key 39) must be installed along with a single cap screw (key 47). Field conversion from 60-degree to 90-degree rotation, or vice versa, is possible but the appropriate parts must first be ordered (see the parts list).

1. Loosen the hex nuts (key 39 and, if used, key 37) on both travel stop screws (key 35 and, if used, key 9) and back out both screws slightly.
2. Stroke the actuator until the valve disk or ball is in either the open or closed position as indicated by the pointer on the actuator travel indicator (key 28). If either of the travel stop screws is not backed out far enough to allow adjustment to either the open or closed position, repeat step 1 of this procedure until adequate clearance is allowed.

3. When either position is obtained, rotate the appropriate travel stop screw into the housing (key 15) until contact with the lever (key 19) is felt. Make sure the travel stop screw is snug against the lever.
4. Tighten the appropriate hex nut to lock the travel stop screw in position.
5. To complete the adjustment, repeat this procedure on the remaining travel stop screw.

Principle of Operation

Individual piston movement is accomplished by loading air pressure on one side of the piston and unloading air pressure from the other side of the piston. In the 1069 actuator, one piston moves upward while the other piston moves downward, or vice versa, to provide a rotary torque output that either opens or closes the valve body.

If a positioner is not used with the control valve assembly, a loading device such as a four-way switching valve must be provided. The loading device is not furnished with the actuator.

If a positioner is used with the control valve assembly, only one positioner is required to control both actuator pistons. The positioner should be connected in series to both actuator cylinders. Consult the positioner instruction manual for actuator principle of operation with positioner.

Maintenance

Actuator parts are subject to normal wear and must be inspected and replaced as necessary. The frequency of inspection and replacement depends upon the severity of service conditions. This section provides procedures for both disassembly and assembly of parts. Key numbers referenced in these procedures are shown in figure 4, unless otherwise specified.

▲ WARNING

Sudden release of pressure or uncontrolled process fluid can occur when repair work is done. To avoid personal injury or damage to the process system, perform the following before starting maintenance operations:

- Do not remove the actuator from the valve while the valve is still pressurized.
- Always wear protective gloves, clothing, and eyewear when performing any maintenance operations to avoid personal injury.
- Disconnect any operating lines providing air pressure, electric power, or a control signal to the actuator. Be sure the actuator cannot suddenly open or close the valve.
- Use bypass valves or completely shut off the process to isolate the valve from process pressure. Relieve process pressure on both sides of the valve. Drain the process media from both sides of the valve.
- Vent the power actuator loading pressure and relieve any actuator spring precompression.
- Use lock-out procedures to be sure that the above measures stay in effect while you work on the equipment.
- The valve packing box may contain process fluids that are pressurized, *even when the valve has been removed from the pipeline*. Process fluids may spray out under pressure when removing the packing hardware or packing rings, or when loosening the packing box pipe plug.
- Check with your process or safety engineer for any additional measures that must be taken to protect against process media.

Disassembly

The following procedure describes how to disassemble the actuator for inspection and replacement of parts. When performing this procedure, disassemble only those parts necessary to accomplish the job.

1. Bypass the control valve, reduce loading pressure to atmospheric, and then remove the tubing or piping from both actuator cylinders.
2. Remove the positioner, if one is used.
3. Remove the cap screws and washers (keys 25 and 38) and then remove the cover (key 24). If a manual operator is used, it is removed with the cover.
4. Remove the inner retaining ring (key 22) and slide the hub (key 21) from the cover (key 24). If a manual operator is used, refer to the manual operator section for disassembly instructions.
5. Check the condition of the bearing (key 23). If replacement of the bearing is necessary, remove the self-tapping screws and travel indicator scale (keys 27 and 26) before replacing the bearing.
6. Remove the cap screws and anti-rotator assemblies (keys 8 and 42).
7. Note the lever/valve shaft orientation. Then loosen the cap screws (key 20) and rotate the set screw (key 41) clockwise slightly to spread the split portion of the lever (key 19). Remove the lever through the openings in the housing (key 15). For an 8510 valve body, the disk must be open approximately 20 degrees to allow enough clearance for lever removal. For a V250 valve body, the ball must be open approximately 70 degrees to allow enough clearance for lever removal. Consult the valve body instruction manual for assistance during this step.

CAUTION

Do not use a hammer or similar tool to drive the lever (key 19) off the valve shaft. Driving the lever could damage internal valves parts. On some valve types, driving the lever could move the valve disk and bearings away from the centered position, causing subsequent damage to valve parts as the valve is being operated.

If necessary, use a wheel puller to remove the lever. It is okay to tap the wheel puller screw lightly to loosen the lever, but hitting the screw with excessive force could also damage valve parts or disrupt the centered position of the valve disk and bearings.

8. Remove both rod end bearings (key 7).
9. Unscrew the cap screws (key 16) and remove both cylinder flanges (key 2) with attached cylinder assemblies (key 1). Then remove both sliding seals (key 13), both thrust washers (key 36), and both seal support cylinders (key 14).
10. Remove the cap screws (key 3) and separate each cylinder flange from each cylinder assembly.
11. Pull each piston rod (key 6) with attached piston (key 4) out of each respective cylinder assembly.
12. Check and, if necessary, replace the O-rings (keys 5 and 10). For ease of assembly, lubricate the O-rings with lithium grease if they are removed.
13. To separate each piston and piston rod, unscrew the hex nut (key 43). Check both piston rods for nicks and scratches that could disrupt the sealing surfaces of the sliding seals and O-rings (keys 13 and 11). Replace either piston rod if necessary.
14. Inspect and, if necessary, replace the O-rings (keys 11 and 12) and both thrust washers (key 36). For ease of assembly, lubricate the O-rings with lithium grease if they are removed.
15. Unscrew the cap screws (key 18) and remove the housing.
16. Unbolt the mounting yoke (key 17) from the valve body. Then, slide the mounting yoke off the valve shaft.
17. Check the bearing (key 40). Press out and replace the bearing if necessary.
18. Refer to the assembly procedure for replacement of parts.

Assembly

This procedure assumes that the actuator is completely disassembled. If the actuator is not completely disassembled, start these instructions at the appropriate step. When assembling parts, make sure that all O-rings are positioned correctly as shown in figure 4 of the instruction manual. For ease of assembly, lubricate all O-rings with lithium grease.

1. If the bearing (key 40) is removed, press in the new bearing. The end of the bearing should be flush with the bottom of the recess in the mounting yoke (key 17).
2. Slide the mounting yoke over the valve shaft, and secure it to the valve with the valve mounting cap screws. Refer to the appropriate valve body instruction manual for bolting torques for these cap screws.

CAUTION

Refer to table 2 for bolting torques of actuator bolts and cap screws. Exceeding any torque requirement may impair the safe operation of the actuator.

3. To aid installation of the lever, apply lithium grease (key 45) to the exposed valve shaft spline. It may be necessary to rotate the set screw (key 41) clockwise slightly to spread the split portion of the lever and allow installation on the valve shaft.
4. Consult the appropriate valve body instruction manual for lever/valve shaft orientation marks and slide the lever into place. Consult figure 3 for the appropriate lever operating clearances. When the lever is in place, back off the set screw (key 41) so that the lever can be clamped onto the valve shaft. Secure the assembly with the cap screws (key 20). Tighten the cap screws (key 20) to 271 N•m (200 lbf • ft).
5. Connect each rod end bearing to the lever with a cap screw and anti-rotator assembly (keys 8 and 42). Cap screw torques are listed in table 2. Tighten the cap screws (key 8) to 407 N•m (300 lbf • ft).
6. Refer to figure 2 for the desired position of the housing (key 15). Install the housing over the lever and secure it to the mounting yoke with the cap screws (key 18).
7. Apply lithium grease (key 45) to the surface of both sliding seals (key 13) and thrust washers (key 36).
8. To install each cylinder flange, proceed as follows:

Lay the cylinder flange (key 2) upside down on a flat surface and then install each of the following parts in order: the O-ring (key 12), the sliding seal with installed O-ring (keys 13 and 11), the thrust washer (key 36), and the seal support cylinder (key 14). Then while holding the cylinder flange assembly together with both hands, turn the assembly over and place it onto the housing. Temporarily rotate the cylinder flange to gain access to the three cap screw holes located directly above the housing web and install three cap screws and washers (keys 3 and 69) into the appropriate holes in the cylinder flange. Return the cylinder flange to its normal position and secure it to the housing with the cap screws (key 16).

CAUTION

Use care when inserting each piston rod. Nicks or scratches in the exposed surfaces of either of the piston rods could disrupt the sealing surfaces of the sliding seals and O-rings (keys 13 and 11).

9. Insert each piston rod (key 6) through each sliding seal (key 13) and thread each rod into each rod end bearing (key 7), leaving approximately 3 or 4 threads of each piston rod exposed. Using a large wrench, grip the flats on the bottom end of one of the piston rods, and then let the wrench stop against the actuator housing. Install a washer (key 70), the piston (key 4) with attached O-rings (keys 5 and 71), and another washer (key 70) to the piston rod. Then, tighten the cap screw (key 43) against the piston. Remove the wrench and thread the piston rod completely

into the rod end bearing. Tighten the piston rod to 203 N•m (150 lbf•ft). Use this same procedure to install the second piston rod assembly. When both piston rods are installed, apply lithium grease (key 45) to the cylindrical surface of each piston rod.

10. Apply lithium grease (key 45) to the inside wall of each cylinder (key 1).
11. Install an O-ring (key 10) into each cylinder flange. Then, secure each cylinder to each cylinder flange with the cap screws and washers (keys 3 and 69). Note that six of these cap screws and washers will already be inserted in the three cap screw holes located directly above the housing web for each cylinder.
12. If a valve positioner is to be used, consult the separate valve positioner instruction manual for proper installation.
13. Install the hub (key 21) into the cover (key 24) and secure it with the retaining rings (key 22). If a new bearing (key 23) is required, it should be installed into the cover before the hub.
14. If necessary, install the travel indicator scale (key 26) and secure it with the self-tapping screws (key 27). Then, install the travel indicator (key 28) to the hub and secure it with the self-tapping screws (key 29). If an optional manual operator is used, make sure that the travel indicator and travel indicator scale (keys 69 and 70) are secured in place with the self-tapping screws (key 71).
15. Note the valve disk or ball position and direction of rotation.
 - a. If a manual operator is not used, position the travel indicator and hub (keys 28 and 21) according to the valve disk or ball position just noted. Replace the cover (key 24), and secure it with the washers and cap screws (keys 38 and 25). Do not stroke the actuator past the fully open or closed position while the cover is off.
 - b. If a manual operator is used, refer to the manual operator section of this instruction manual.
16. Perform the adjustment procedures before proceeding to the loading connection procedure.

Manual Operator

This section presents installation and operation instructions for the manual operator used with 1069 actuators.

Note

When the 1069 actuator is equipped with an auxiliary manual operator, make certain that a cylinder bypass valve (key 53) is installed and used to equalize cylinder pressure during handwheel operation. Operating the manual operator by itself against the force of differential cylinder pressures will be difficult or even impossible.

Installation

Note

To aid in installation, make sure that the manual operator is in the engaged position during installation.

To install the manual operator, perform the following steps:

1. Attach the actuator cover (key 24, figure 4) to the manual operator gear box (key 53) with the cap screws, washers, and spacer (keys 62, 68, and 67).
 2. Note the valve disk or ball position and direction of rotation.
 3. Align the four zero marks on the end of the valve shaft with the four zero marks on the inside end of the actuator adaptor (key 21, figure 4).
-

Note

To ensure that the adaptor zero marks are oriented correctly, make sure that the relative position of the travel indicator (key 69) on the travel indicator scale (key 70) corresponds to the open or closed position of the valve.

4. Secure the manual operator to the actuator housing (key 15, figure 4) with the cap screws and washers (keys 25 and 38, figure 4).
5. Check that the position of the travel indicator corresponds with the open or closed position of the valve. If the travel indicator is not positioned correctly, repeat steps 2, 3, and 4 of this procedure until the correct position is obtained.

Engaging and Disengaging the Manual Operator

To engage or disengage the manual operator, perform the following steps:

1. To change from the engaged to the disengaged position, or vice versa, temporarily pull the declutching handwheel out from the gear box (key 53) as far as it will go.
2. Rotate the declutching handwheel 180 degrees in either direction (clockwise or counterclockwise).

3. When the pointer on the declutching handwheel assembly is pointing to the correct marking on the gear box housing, release the declutching handwheel.
 - To engage the manual operator, position the declutching handwheel pointer to the marking that has two arrows facing toward each other.
 - To disengage the manual operator, position the declutching handwheel pointer to the marking that has two arrows facing away from each other.
4. If necessary, rotate the main handwheel several degrees in either direction to ensure that the gear teeth of the interlocking gears mesh correctly. Also, if necessary, push in the declutching handwheel firmly while it is in the appropriate position to help interlock the gears.

Operation

Rotate the main handwheel counterclockwise to open the valve and clockwise to close the valve.

Parts Ordering

When corresponding with your Emerson Process Management sales office about this equipment, refer to the serial number found on the actuator nameplate (key 32, figure 4). Also specify the complete 11-character part number from the following parts list when ordering replacement parts.

⚠ WARNING

Use only genuine Fisher replacement parts. Components that are not supplied by Emerson Process Management should not, under any circumstances, be used in any Fisher valve, because they may void your warranty, might adversely affect the performance of the valve, and could cause personal injury and property damage.

Parts List

Note

Part numbers are shown for recommended spares only. For part numbers not shown, contact your Emerson Process Management sales office.

1069 Actuator (figure 4)

Key	Description	Part Number
1	Cylinder, aluminum (2 req'd)	
2	Cylinder Flange, aluminum (2 req'd)	
3	Cap Screw, zn pl steel (32 req'd)	
4	Piston, aluminum & PTFE (2 req'd)	
5*	O-Ring, nitrile (2 req'd)	1H862606992
6	Piston Rod, cr pl S41600 stainless steel (2 req'd)	
7	Rod End Bearing, alloy steel & PTFE (2 req'd)	
8	Cap Screw, zn pl steel (2 req'd)	
9	Travel Stop Screw, zn pl steel, 60-degree rotation only	
10*	O-Ring, nitrile (2 req'd)	1H862606992
11*	O-Ring, nitrile (2 req'd)	1D542906992
12*	O-Ring, nitrile (2 req'd)	1P233206992
13	Sliding Seal, aluminum (2 req'd)	
14	Seal Support Cylinder, aluminum (2 req'd)	
15	Housing, cast iron	
16	Cap Screw, zn pl steel (20 req'd)	
17	Mounting Yoke, cast iron	
18	Cap Screw, zn pl steel (8 req'd)	
19	Lever, ductile iron	
20	Cap Screw, zn pl steel (2 req'd)	
21	Hub, aluminum or S41600 stainless steel ⁽¹⁾ (not req'd w/manual operator)	
21	Adaptor, S17400 stainless steel, heat-treated (Use w/manual operator only)	
22	Retaining Ring, zn pl carbon steel (2 req'd)	
23	Bearing, fiberglass/PTFE	
24	Cover, aluminum/iridite	
25	Cap Screw, zn pl steel (8 req'd)	
26	Travel Indicator Scale, stainless steel (Not req'd w/manual operator)	
27	Self Tapping Screw, pl carbon steel (2 req'd) (not req'd w/manual operator)	
28	Travel Indicator, stainless steel (not req'd w/manual operator)	
29	Self Tapping Screw, pl carbon steel (2 req'd) (not req'd w/manual operator)	
30	Positioner Plate, steel (none req'd w/positioner)	
30	Positioner Adaptor, aluminum (use w/3610JP positioner only)	

Key	Description	Part Number
31	Cap Screw, zn pl steel (4 req'd)	
32	Nameplate, stainless steel	
33	Drive Screw, stainless steel (4 req'd)	
34	Travel Stop Nut, steel, 60-degree rotation only	
35	Travel Stop Screw, zn pl steel 60-degree rotation (1 req'd) 90-degree rotation (2 req'd)	
36	Thrust Washer, PTFE (2 req'd)	
37	Hex Nut, zn pl steel, 60-degree rotation only	
38	Washer, pl carbon steel (8 req'd)	
39	Hex Nut, zn pl steel 60-degree rotation (1 req'd) 90-degree rotation (2 req'd)	
40	Bearing, fiberglass/PTFE	
41	Set Screw, carbon steel	
42	Anti-Rotator Assembly, steel (2 req'd)	
43	Cap Screw, zn pl carbon steel (2 req'd)	
44	Plastic lead Seal Sealant	
45	Lithium grease	
46	Cap Screw, zn pl steel, 60-degree rotation only	
47	Cap Screw, zn pl steel, 90-degree rotation only	

Note

Key numbers 48 through 67 are to be used with valve positioner only, unless otherwise specified. And key numbers 48 through 51 and 58 through 66 are to be used with volume boosters only.

48	Elbow (2 req'd)
49	Nipple (2 req'd)
50	Elbow (none req'd w/manual operator)
51	Cross (Use w/manual operator only)
52	Tubing, ⁽⁵⁾ 3/8-inch (9.5 mm) outer diameter (2 req'd - specify accessories used w/actuator)
53	Bypass Valve (use w/manual operator only)
54	Bypass Tubing, (use w/manual operator only) (2 req'd - specify accessories used w/actuator)
55	Tee ⁽²⁾ (2 req'd)
56	Connector ⁽⁵⁾ (2 req'd)
57	Tee ⁽⁵⁾ (use w/manual operator only) (2 req'd)
58	Elbow (use w/manual operator only)
59	Tee (use w/manual operator only)
60	Tee (3 req'd w/o manual operator; 2 req'd w/manual operator)
61	Elbow (use w/manual operator only)
63	Hose Assembly, Operation (2 req'd)
64	Hose Assembly, Supply
65	Hose Assembly, Bypass (use w/manual operator only)
66	Needle Valve (use w/manual operator only)
69	Washer, zn pl carbon steel (32 req'd)
70	Washer, S17400 stainless steel (4 req'd)
71	O-Ring, nitrile (2 req'd)

*Recommended spare parts

1. Either aluminum or 416 stainless steel hub material will be supplied depending on manufacturing location.

2. This part can also be used without valve positioner.

Figure 4. Fisher 1069 Actuator Assembly

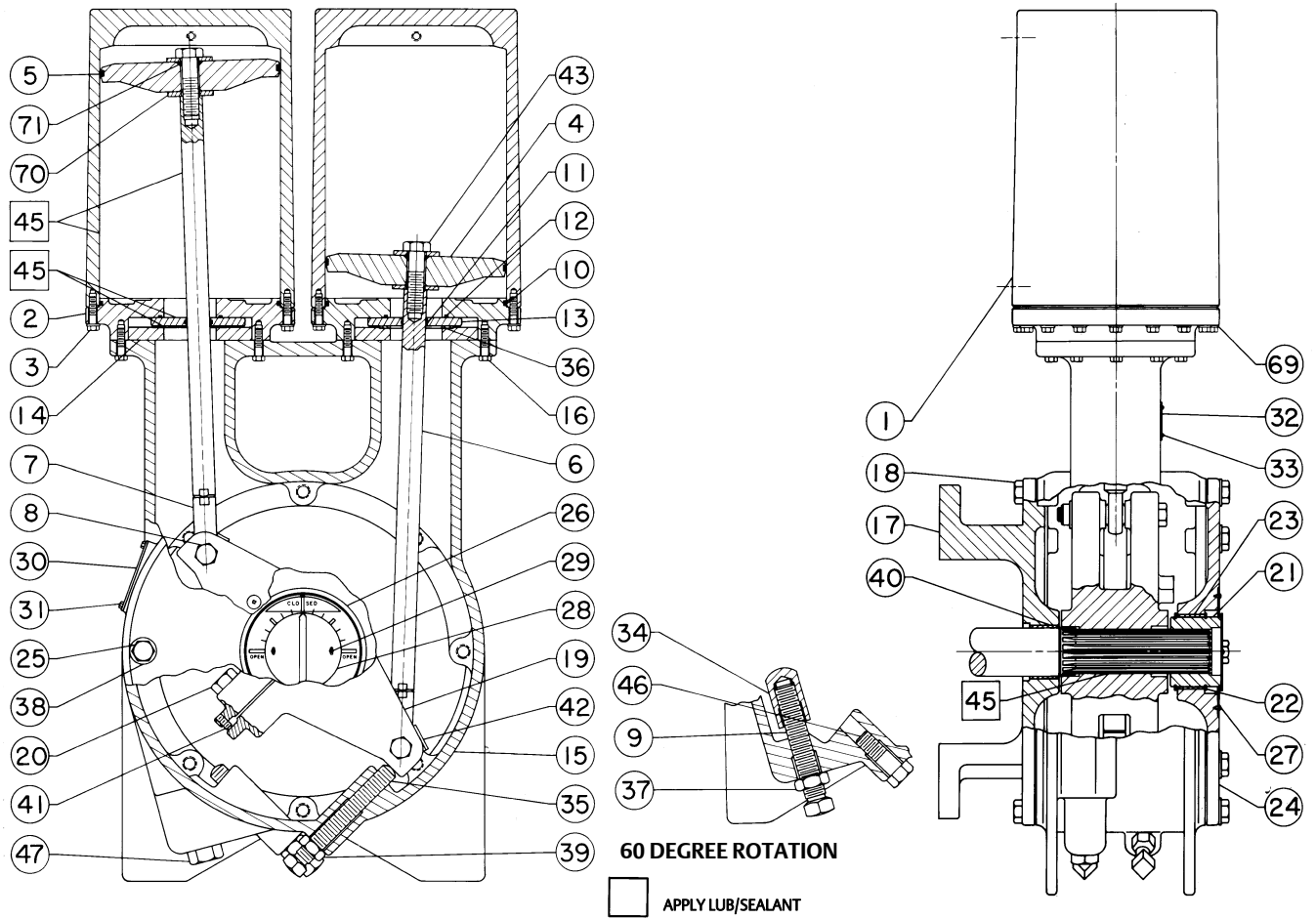

58A8035-B Sht 1 & 2

Neither Emerson, Emerson Process Management, nor any of their affiliated entities assumes responsibility for the selection, use or maintenance of any product. Responsibility for proper selection, use, and maintenance of any product remains solely with the purchaser and end user.

Fisher is a mark owned by one of the companies in the Emerson Process Management business division of Emerson Electric Co. Emerson Process Management, Emerson, and the Emerson logo are trademarks and service marks of Emerson Electric Co. All other marks are the property of their respective owners.

The contents of this publication are presented for informational purposes only, and while every effort has been made to ensure their accuracy, they are not to be construed as warranties or guarantees, express or implied, regarding the products or services described herein or their use or applicability. All sales are governed by our terms and conditions, which are available upon request. We reserve the right to modify or improve the designs or specifications of such products at any time without notice.

Emerson Process Management

Marshalltown, Iowa 50158 USA

Sorocaba, 18087 Brazil

Chatham, Kent ME4 4QZ UK

Dubai, United Arab Emirates

Singapore 128461 Singapore

www.Fisher.com**EMERSON™**
Process Management