

**Fisher® Slurry
Vee-Ball™
Rotary Valve**

Your best choice for erosive slurry control.



The Fisher® Slurry Vee-Ball™ Control Valve with Erosion-Resistant Trim

The industry's best rotary control valve for severe erosive slurries. A proven choice that total internal protection for:

- Longer Operating Life
- Lower Life Cycle Cost
- Higher Operational Safety

How did we do it? We fitted the Fisher Vee-Ball valve with a body liner, V-notch ball, and flow ring all constructed of high-chrome iron, which provides superior protection against erosive flow. All components of the Slurry Vee-Ball Valve work together to deliver new levels of industry performance.

Consider These Slurry Vee-Ball Advantages:

- Minimal impingement and wear on the downstream piping through an engineered flowstream
- Longer service life with heavy section flow ring, ball, and body liner
- Choice of erosion-resistant trim from high-chrome iron to tough ceramic
- Matching of valve bores to pipe bore avoids flange face scouring
- Greater protection of flange faces with hardened trim
- Integral flanges ensure correct alignment and simplified installation
- Easy maintenance with no screw threads, press fits, or O-rings
- Lower maintenance costs—typically only the flow ring and ball experience the effects of erosion
- High velocity outlet flow is directed downstream minimizing piping wall erosion.



Choice of Trim Levels

- Trim Level One: High-chrome iron flow ring, ball, bearing shrouds, and body liner
- Trim Level Two: Same erosion-fighting parts as Level One, plus a partially stabilized zirconia (PSZ) flow ring insert
- Trim Level Three: Same as Level Two, plus a PSZ ball

Actuator and FIELDVUE™ Digital Valve Controller

A choice of Fisher pneumatically operated rotary actuators makes it easy to specify a Vee-Ball valve for accurate throttling applications. And when equipped with the industry-leading FIELDVUE™ digital valve controller, the Vee-Ball valve can become an integral part of systems operating under HART® or FOUNDATION™ fieldbus protocols.

Availability

Sizes: 3, 4, 6, 8, 10, and 12-inch

DN80, 100, 150, 200, 250, and 300

End Connection & Ratings: ANSI Class 150 raised-face flanges

Flow Characteristic: Modified equal percentage

Complete specifications found in the Fisher V150S Product Bulletin D103154X012

Get the Slurry Vee-Ball Control Valve

Contact your local Emerson Process Management sales office or sales representative location where highly skilled and experienced applications personnel are ready to help you take advantage of the many benefits of Fisher valves.



As a core component of the PlantWeb™ digital plant architecture, the Fisher Digital Valve gives you the power to capture valve diagnostic data.

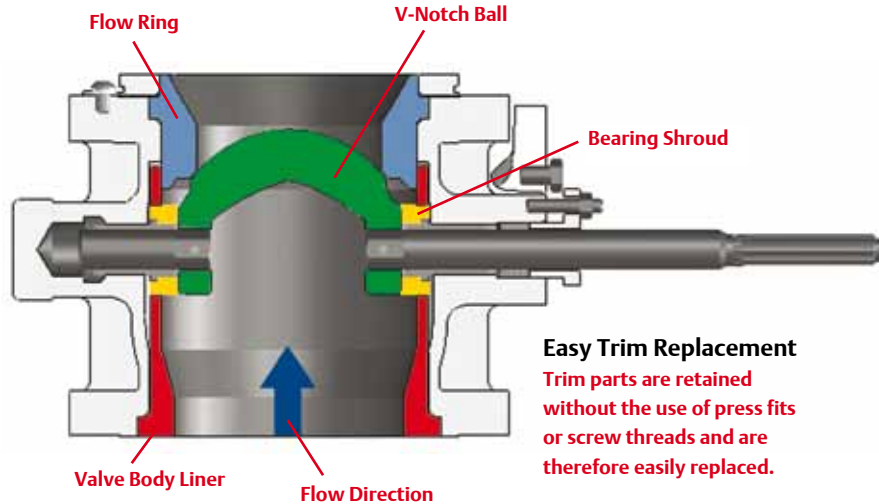

Easy Trim Replacement

Trim parts are retained without the use of press fits or screw threads and are therefore easily replaced.



Drop-In Style Flow Ring

An optional, PSZ ceramic insert for the flow ring provides added protection against high velocity erosive flow.

© Fisher Controls International LLC 2010, 2011 All Rights Reserved.

Fisher, Vee-Ball, HART, FOUNDATION, and FIELDVUE are marks owned by one of the companies in the Emerson Process Management business section of Emerson Electric Co. Emerson Process Management, Emerson, and the Emerson logo are trademarks and service marks of Emerson Electric Co. All other marks are the property of their respective owners.

Emerson Process Management
Marshalltown, Iowa 50158 USA
Sorocaba, 18087 Brazil
Chatham, Kent ME4 4QZ UK
Dubai, United Arab Emirates
Singapore, 128461 Singapore
www.EmersonProcess.com/Fisher

D351028X012 / MW66 (H:) / Jul 11

The contents of this publication are presented for informational purposes only, and while every effort has been made to ensure their accuracy they are not to be construed as warranties or guarantees, express or implied, regarding the products or services described herein or their use or applicability. All sales are governed by our terms and conditions, which are available upon request. We reserve the right to modify or improve the designs or specifications of such products at any time without notice. Neither Emerson, Emerson Process Management, nor any of their affiliated entities assumes responsibility for the selection, use or maintenance of any product. Responsibility for proper selection, use, and maintenance of any product remains solely with the purchaser and end-user.