

# Fisher™ 685SE and 685SR Piston Actuator

## Contents

Introduction .....	1
Scope of Manual .....	1
Description .....	1
Specifications .....	2
Principle of Operation .....	3
Installation .....	6
Three-Way Valve Applications Note .....	6
Actuator Mounting .....	7
Handwheel Operation .....	8
Maintenance .....	9
Actuator Removal .....	10
685SE Seal and O-ring Replacement .....	10
685SR Seal and O-ring Replacement .....	12
Parts Ordering .....	13
Parts Kits .....	13
Parts List .....	14

Figure 1. Fisher 685SE Piston Actuator



X0993

## Introduction

### Scope of Manual

This instruction manual provides information on the installation, maintenance, and parts ordering for Fisher 685SE and 685SR piston actuators. Refer to separate instruction manuals for information regarding other equipment and accessories used with these actuators.

Do not install, operate, or maintain 685SE or 685SR actuators without being fully trained and qualified in valve, actuator, and accessory installation, operation, and maintenance. To avoid personal injury or property damage, it is important to carefully read, understand, and follow all the contents of this manual, including all safety cautions and warnings. If you have any questions about these instructions, contact your [Emerson sales office](#) or Local Business Partner before proceeding.

### Description

The 685SE and 685SR are medium to large spring-return double-acting piston actuators that provide accurate, high thrust output for short to long travel applications. These actuators are designed for use with a variety of medium to large Fisher sliding-stem control valves including the easy-e™, FB, TBX, CVX, HP, EH, and 461.

These actuators feature an internal bias spring that forces the actuator piston rod to extend (685SE) or retract (685SR) upon a loss of supply pressure, thereby ensuring a fail-closed or fail-open mode of operation. This effectively eliminates the need for a trip valve and volume tank in most constructions.

Table 1. Specifications

**Operating Pressure<sup>(1)</sup>**

Minimum: 2.7 bar (40psig)

Maximum Allowable: 10.3 bar (150 psig)

Consult your [Emerson sales office](#) or Local Business Partner for supply pressures under 2.7 bar (40 psi)

**Travel<sup>(2)</sup>**

25 mm (1 inch) through 610 mm (24 inch).

See table 2

**Thrust Capabilities**

Designed to meet the application requirements

**Piston Diameter and Area<sup>(2)</sup>**

Available in 51 mm (2 inch) increments between 254 mm (10 inch) and 711 mm (28 inch). See table 2

**Operative Temperature Limits**

Standard: -40 to 93°C (-40 to 200°F)

Low Temperature: -54 to 93°C (-65 to 200°F)<sup>(3)</sup>

High Temperature: -32 to 204°C (-25 to 400°F)<sup>(3)</sup>

**Pressure Connections**

See table 3

**Yoke Boss and Valve Stem Diameter**

■ 90.5 mm (3-9/16 inch) yoke boss with 19.1 mm (3/4 inch) stem ■ 127 mm (5 inch) yoke boss with 25.4 mm (1 inch) stem ■ 127 mm (5 inch) yoke boss with 31.8 mm (1-1/4 inch) stem ■ 127 mm (5H inch) yoke boss with 32 mm (1-1/4 inch) stem ■ 178 mm (7 inch) yoke boss with 51 mm (2 inch) stem

**Instrument Mounting**

Mounting kits are available for use with FIELDVUE™ DVC6200 Series digital valve controllers

**Manual Override (optional)**

Size 10 to 26: Handwheel

Size 28: Hydraulic Hand-pump<sup>(4)</sup>

**Construction Materials**

PART	MATERIAL
Yoke	ASTM A36 (steel)
Piston	ASTM A36 (steel)
Cylinder	254 to 559 mm (10 to 22 inch) cylinder: 1026 DOM (steel) with chrome-plated bore 610 to 711 mm (24 to 28 inch) cylinder: ASTM A516 Grade 70 (steel) with fluoropolymer coated bore
Upper/Lower Heads	ASTM A36 (steel)
Outer Spring Cartridge	ASTM A36 (steel)
Tie Bolt	ASTM A311 1045, Class B (steel)
Piston Rod	S31603 (316L Stainless Steel)
Stem Connector	ASTM A36 (steel)

**Weights**

See tables 4 and 5

**Lifting Point Load Ratings**

See table 6

**Optional Certifications<sup>(5)</sup>**

- Pressure Equipment Directive (PED) 2014/68/EU
- Complies with the requirements of ATEX Group II Category 2 Gas and Dust

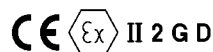

- Customs Union Technical Regulations (CU TR) 010/2011 and 012/2011



Fisher 685SE and 685SR actuators have been evaluated for ignition hazard and certified for CUTR 012/2011 under “protection by constructional safety”. To ensure conformity with CUTR, only Fisher parts and materials can be used.

1. The pressure/temperature limits in this instruction manual and any other applicable standard or code should not be exceeded.

2. Contact your Emerson sales office for larger travels or cylinder diameters. The Fisher 657, 667, and 585C family of actuators can be used for smaller travels or cylinder diameters.

3. Contact your Emerson sales office for applications requiring low or high temperature requirements.

4. Contact your Emerson sales office for applications requiring a manual override on a size 28 actuator.

5. Refer to the product nameplates to determine which certifications each actuator construction possesses.

## Specifications

Specifications for the 685SE and 685SR piston actuators are shown in table 1. Refer to the nameplate affixed to the actuator yoke for specifications specific to individual constructions.

## Principle of Operation

685SE and 685SR piston actuators utilize a piston that moves inside of a cylinder to generate thrust. A seal contained on the circumference of the piston provides a seal between the piston and the cylinder, preventing supply pressure leakage. A bias spring that is either below or above the piston, depending on construction, will retract or extend the piston rod upon a loss of supply pressure. This fail action will result in forcing an attached control valve to either fail-open or fail-closed.

From an equilibrium state, the actuator operates by reacting to a force unbalance that is created by increasing supply pressure on one side of the piston, and decreasing it on the other. This moves the piston up or down, and results in a repositioning of the attached control valve. Travel can be adjusted using travel limits within a valve positioner, which limit the travel range of the actuator. The optional handwheel manual override does not have the ability to act as a hard travel stop.

An optional handwheel or hydraulic hand-pump manual override is capable of extending or retracting the actuator manually and can be engaged at any position from full open to full close. This handwheel override utilizes a worm gear assembly that is attached to the stem connector and not attached to the cylinder or piston rod. This enables the handwheel manual override function to reposition the control valve even if the actuator cylinder or piston is removed for maintenance. The hydraulic hand-pump override utilizes a hydraulic cylinder that is connected to the piston rod, which is controlled by a manual hand-pump.

Table 2. Standard Constructions<sup>(1)</sup>

ACTUATOR SIZE	PISTON DIAMETER		PISTON ROD		PISTON AREA		VALVE STEM CONNECTOR SIZE		YOKE BOSS DIAMETER		VALVE TRAVEL			
	mm	Inch	mm	Inch	cm <sup>2</sup>	Inch <sup>2</sup>	mm	Inch	mm	Inch	Minimum		Maximum	
											mm	Inch	mm	Inch
10	254	10	16	2.41	507	79	19	3/4	90	3-9/16	25	1	203	8
							25	1	127	5	25	1	203	8
							32 or 51	1-1/4 or 2	127 or 178	5H or 7	25	1	610	24
12	305	12	16	2.41	730	113	19	3/4	90	3-9/16	25	1	154	6
							25	1	127	5	25	1	203	8
							32 or 51	1-1/4 or 2	127 or 178	5H or 7	25	1	610	24
14	356	14	32	4.91	993	154	25	1	127	5	25	1	203	8
							32 or 51	1-1/4 or 2	127 or 178	5H or 7	25	1	610	24
							25	1	127	5	25	1	203	8
16	406	16	32	4.91	1297	201	25	1	127	5	25	1	203	8
							32 or 51	1-1/4 or 2	127 or 178	5H or 7	25	1	610	24
							25	1	127	5	25	1	203	8
18	457	18	32	4.91	1642	254	25	1	127	5	25	1	203	8
							32 or 51	1-1/4 or 2	127 or 178	5H or 7	25	1	610	24
							25	1	127	5	25	1	203	8
20	508	20	46	7.07	2027	314	25	1	127	5	25	1	203	8
							32 or 51	1-1/4 or 2	127 or 178	5H or 7	25	1	610	24
							25	1	127	5	25	1	203	8
22	559	22	46	7.07	2452	380	25	1	127	5	25	1	203	8
							32 or 51	1-1/4 or 2	127 or 178	5H or 7	25	1	610	24
							25	1	127	5	25	1	203	8
24	610	24	62	9.62	2919	452	25	1	127	5	25	1	203	8
							32 or 51	1-1/4 or 2	127 or 178	5H or 7	25	1	610	24
							25	1	127	5	25	1	203	8
26	660	26	62	9.62	3425	531	25	1	127	5	25	1	203	8
							32 or 51	1-1/4 or 2	127 or 178	5H or 7	25	1	610	24
							25	1	127	5	25	1	203	8
28	711	28	62	9.62	3973	616	25	1	127	5	25	1	203	8
							32 or 51	1-1/4 or 2	127 or 178	5H or 7	25	1	610	24
							25	1	127	5	25	1	203	8

1. Consult your [Emerson sales office](#) or Local Business Partner for additional sizes.

Table 3. Pressure Connections

ACTUATOR SIZE	SUPPLY CONNECTION	
	Size, NPT	Quantity (Top/Bottom)
10	3/8	1/1
		2/2 (standard)
12	3/4	1/1
		2/2 (standard)
14 to 28	3/4 (standard), 1, or 1-1/4	1/1
		2/2 (standard)
	3/4 (standard), 1, or 1-1/4	1/1
		2/2 (standard for 3/4 NPT only)

Table 4. Approximate Weights for Constructions without Manual Override

ACTUATOR TYPE	MAX VALVE TRAVEL	APPROXIMATE WEIGHT FOR ACTUATOR SIZE, kg (lbs)									
	mm (inches)	10	12	14	16	18	20	22	24	26	28
685SE	25 (1.00)	109 (241)	147 (324)	221 (487)	270 (596)	315 (694)	462 (1018)	489 (1079)	680 (1500)	776 (1710)	931 (2053)
	51 (2.00)	114 (251)	156 (344)	231 (510)	284 (625)	329 (725)	479 (1056)	510 (1124)	704 (1551)	802 (1768)	957 (2110)
	102 (4.00)	122 (270)	174 (383)	252 (556)	310 (683)	358 (789)	514 (1132)	551 (1215)	750 (1654)	855 (1884)	1009 (2225)
	152 (6.00)	131 (289)	192 (423)	273 (601)	336 (740)	387 (852)	548 (1209)	592 (1305)	797 (1757)	907 (2000)	1061 (2339)
	203 (8.00)	140 (308)	210 (462)	293 (647)	362 (798)	415 (916)	583 (1285)	633 (1396)	843 (1859)	960 (2116)	1113 (2454)
	254 (10.00)	148 (327)	227 (501)	314 (693)	388 (855)	444 (979)	617 (1361)	674 (1486)	890 (1962)	1012 (2232)	1165 (2569)
	305 (12.00)	157 (346)	245 (541)	335 (738)	414 (913)	473 (1042)	652 (1437)	715 (1577)	937 (2065)	1065 (2348)	1217 (2683)
	356 (14.00)	165 (365)	263 (580)	356 (784)	440 (971)	502 (1106)	686 (1513)	756 (1667)	983 (2168)	1118 (2464)	1269 (2798)
	406 (16.00)	174 (384)	281 (619)	376 (829)	466 (1028)	530 (1169)	721 (1589)	797 (1758)	1030 (2270)	1170 (2580)	1321 (2912)
	457 (18.00)	183 (403)	299 (659)	397 (875)	493 (1086)	559 (1233)	756 (1667)	838 (1848)	1076 (2373)	1223 (2696)	1373 (3027)
	508 (20.00)	191 (422)	317 (698)	418 (921)	519 (1143)	588 (1296)	790 (1742)	879 (1939)	1123 (2476)	1275 (2812)	1425 (3142)
	559 (22.00)	200 (441)	334 (737)	438 (966)	545 (1201)	617 (1359)	825 (1818)	921 (2029)	1170 (2578)	1328 (2928)	1477 (3256)
610 (24.00)	209 (460)	352 (776)	459 (1012)	571 (1259)	645 (1423)	859 (1894)	962 (2120)	1216 (2681)	1381 (3044)	1529 (3371)	
685SR	25 (1.00)	127 (281)	165 (363)	242 (533)	311 (685)	353 (778)	479 (1056)	557 (1228)	760 (1676)	869 (1915)	1101 (2427)
	51 (2.00)	132 (291)	174 (384)	253 (557)	325 (716)	368 (812)	497 (1096)	578 (1273)	784 (1727)	895 (1973)	1127 (2485)
	102 (4.00)	142 (312)	193 (426)	275 (605)	352 (776)	398 (878)	534 (1176)	619 (1364)	830 (1830)	948 (2089)	1179 (2599)
	152 (6.00)	151 (333)	212 (468)	297 (654)	380 (837)	429 (945)	570 (1257)	660 (1454)	877 (1933)	1000 (2206)	1231 (2714)
	203 (8.00)	161 (354)	232 (511)	318 (702)	407 (898)	459 (1012)	606 (1337)	701 (1545)	923 (2035)	1053 (2322)	1283 (2829)
	254 (10.00)	170 (375)	251 (553)	340 (750)	435 (958)	489 (1079)	643 (1417)	742 (1635)	970 (2138)	1106 (2438)	1335 (2944)
	305 (12.00)	180 (396)	270 (595)	362 (798)	462 (1019)	520 (1146)	679 (1497)	783 (1726)	1016 (2241)	1159 (2554)	1387 (3059)
	356 (14.00)	189 (417)	289 (638)	384 (847)	490 (1079)	550 (1212)	716 (1577)	824 (1816)	1063 (2344)	1211 (2670)	1439 (3173)
	406 (16.00)	199 (438)	308 (680)	406 (895)	517 (1140)	580 (1279)	752 (1657)	865 (1907)	1110 (2446)	1264 (2786)	1491 (3288)
	457 (18.00)	208 (459)	328 (722)	428 (943)	545 (1201)	611 (1346)	788 (1738)	906 (1997)	1156 (2549)	1317 (2903)	1544 (3403)
	508 (20.00)	218 (480)	347 (765)	450 (991)	572 (1261)	641 (1413)	825 (1818)	947 (2088)	1203 (2652)	1369 (3019)	1596 (3518)
	559 (22.00)	227 (501)	366 (807)	472 (1039)	600 (1322)	671 (1480)	861 (1898)	988 (2178)	1249 (2754)	1422 (3135)	1648 (3633)
610 (24.00)	237 (522)	385 (849)	493 (1088)	627 (1382)	702 (1547)	897 (1978)	1029 (2269)	1296 (2857)	1475 (3251)	1700 (3747)	

Table 5. Approximate Weights for Constructions with Handwheels

ACTUATOR TYPE	MAX VALVE TRAVEL mm (inches)	APPROXIMATE WEIGHT FOR ACTUATOR SIZE, kg (lbs)								
		10	12	14	16	18	20	22	24	26
685SE	25 (1.00)	167 (369)	212 (468)	336 (742)	381 (839)	432 (953)	603 (1330)	675 (1489)	853 (1881)	941 (2075)
	51 (2.00)	173 (383)	221 (488)	347 (765)	394 (869)	447 (985)	621 (1370)	697 (1536)	876 (1932)	967 (2132)
	102 (4.00)	186 (410)	240 (529)	368 (811)	421 (928)	475 (1048)	658 (1450)	739 (1630)	922 (2033)	1019 (2246)
	152 (6.00)	199 (438)	259 (570)	389 (858)	448 (987)	504 (1111)	694 (1529)	782 (1723)	968 (2134)	1070 (2359)
	203 (8.00)	211 (465)	277 (611)	410 (904)	474 (1046)	532 (1174)	730 (1609)	824 (1817)	1014 (2235)	1122 (2473)
	254 (10.00)	224 (493)	296 (652)	431 (951)	501 (1105)	561 (1237)	766 (1689)	867 (1910)	1060 (2336)	1173 (2586)
	305 (12.00)	236 (521)	314 (693)	452 (997)	528 (1164)	590 (1300)	802 (1769)	909 (2004)	1106 (2438)	1225 (2700)
	356 (14.00)	249 (548)	333 (734)	473 (1043)	555 (1223)	618 (1363)	838 (1849)	951 (2098)	1152 (2539)	1276 (2814)
	406 (16.00)	261 (576)	352 (775)	494 (1090)	581 (1282)	647 (1426)	875 (1928)	994 (2191)	1197 (2640)	1328 (2927)
	457 (18.00)	274 (603)	370 (816)	515 (1136)	608 (1341)	675 (1489)	911 (2008)	1036 (2285)	1243 (2741)	1379 (3041)
	508 (20.00)	286 (631)	389 (857)	536 (1183)	635 (1400)	704 (1552)	947 (2088)	1079 (2378)	1289 (2842)	1431 (3154)
	559 (22.00)	299 (659)	407 (898)	557 (1229)	662 (1459)	732 (1615)	983 (2168)	1121 (2472)	1335 (2944)	1482 (3268)
610 (24.00)	311 (686)	426 (939)	579 (1275)	688 (1518)	761 (1678)	1019 (2248)	1164 (2566)	1381 (3045)	1534 (3382)	
685SR	25 (1.00)	185 (407)	230 (506)	357 (788)	421 (929)	471 (1038)	666 (1468)	743 (1638)	933 (2057)	1034 (2280)
	51 (2.00)	191 (422)	239 (528)	368 (812)	435 (960)	486 (1071)	685 (1510)	764 (1685)	956 (2108)	1060 (2337)
	102 (4.00)	204 (451)	259 (572)	391 (861)	463 (1022)	516 (1137)	723 (1594)	807 (1779)	1002 (2209)	1112 (2451)
	152 (6.00)	218 (480)	279 (616)	413 (910)	491 (1084)	546 (1204)	761 (1677)	849 (1872)	1048 (2310)	1163 (2565)
	203 (8.00)	231 (509)	299 (660)	435 (959)	520 (1146)	576 (1270)	799 (1761)	892 (1966)	1094 (2411)	1215 (2679)
	254 (10.00)	244 (538)	319 (704)	457 (1008)	548 (1208)	606 (1337)	837 (1845)	934 (2059)	1140 (2512)	1267 (2792)
	305 (12.00)	257 (568)	339 (748)	480 (1057)	576 (1270)	636 (1403)	875 (1929)	977 (2153)	1185 (2614)	1318 (2906)
	356 (14.00)	271 (597)	359 (792)	502 (1106)	604 (1332)	667 (1469)	913 (2013)	1019 (2247)	1231 (2715)	1370 (3020)
	406 (16.00)	284 (626)	379 (836)	524 (1155)	632 (1394)	697 (1536)	951 (2096)	1061 (2340)	1277 (2816)	1421 (3134)
	457 (18.00)	297 (655)	399 (880)	546 (1204)	660 (1456)	727 (1602)	989 (2180)	1104 (2434)	1323 (2917)	1473 (3248)
	508 (20.00)	310 (684)	419 (924)	568 (1253)	688 (1518)	757 (1669)	1027 (2264)	1146 (2527)	1369 (3018)	1525 (3361)
	559 (22.00)	324 (714)	439 (968)	591 (1302)	716 (1580)	787 (1735)	1065 (2348)	1189 (2621)	1415 (3120)	1576 (3475)
610 (24.00)	337 (743)	459 (1012)	613 (1351)	745 (1642)	817 (1801)	1103 (2432)	1231 (2715)	1461 (3221)	1628 (3589)	

Table 6. Lifting Point Load Ratings

ACTUATOR SIZE	LIFTING ORIENTATION	NUMBER OF LIFTING POINTS USED	MAXIMUM LOAD	
			kg	lbs
10	Actuator Centerline Horizontal	2	810	1800
12 to 24		2	1540	3400
26 to 28		2	2860	6300
10	Actuator Centerline Vertical	2	2080	4600
12 to 24		2	3760	8300
26 to 28		2	6350	14000

## Installation

### **▲ WARNING**

Always wear protective gloves, clothing, and eyewear when performing any installation operations to avoid personal injury.

To avoid personal injury or property damage caused by bursting of pressure-retaining parts, be certain the cylinder pressure or other pressure ratings do not exceed the limits listed in table 1. Use pressure-limiting or pressure-relieving devices to prevent cylinder pressure or other pressures from exceeding these limits.

Check with your process or safety engineer for any additional measures that must be taken to protect against process media.

If installing into an existing application, also refer to the WARNING at the beginning of the Maintenance section in this instruction manual.

Dropping the actuator and any attached accessories and/or valve may cause personal injury and/or equipment damage. For all mounting procedures use an adequately sized chain, sling, hoist, or crane to handle the actuator and any attached accessories and/or valve. Use caution during lifting and handling to prevent slippage, swinging, faulty equipment connections, or sudden shock loads.

### **CAUTION**

Special care must be taken when installing an actuator in a horizontal service orientation. To avoid cantilever loads on the valve stem and yoke, it is the customer's responsibility to ensure proper support for a horizontal actuator.

When an actuator and control valve are shipped together as a control valve assembly, the actuator is normally mounted on the valve. Follow the valve instructions when installing the valve in the pipeline. If the actuator is shipped separately or if it is necessary to mount the actuator on the valve, perform the actuator mounting procedures in this instruction manual. Refer to the individual product instruction manuals for the installation or mounting of a FIELDVUE DVC6200 digital valve controller or 3610 positioner.

If the actuator is being installed without a positioner, the cylinder loading pressures should be supplied through a 4-way solenoid valve or a switching valve. Pressure connection locations are indicated below:

- 685SE Actuators: Side of the outer spring cartridge and bottom of the lower head.
- 685SR Actuators: Top of the upper head and side of the outer spring cartridge.

The supply pressure medium should be clean, dry filtered air. If the supply source is capable of exceeding the maximum actuator operating pressure or positioner supply pressure, appropriate steps must be taken during installation to protect the positioner and all connected equipment against over pressurization.

The control valve should be located where it will be accessible for servicing. Room should be left above and below the control valve to permit removal of the actuator and valve plug.

## Three-Way Valve Applications Note

In three-way valve applications where the actuator fully strokes at a frequency of once per minute or faster, and the stroking speed is rapid (less than 0.5 seconds per stroke), there is a possibility that the stem can fracture at the plug if the actuator cylinder pressure is greater than 5.5 bar (80 psig). This can cause loss of control of process fluid and further damage to the actuator. Consideration should be given to the use of high-strength, fatigue-resistant stem materials in these applications.

## Actuator Mounting

The following procedure describes how to mount a 685SE or 685SR actuator on a push-down-to-close valve so that the piston rod to valve plug stem connection allows full travel and proper shutoff. Key numbers referenced in the following steps are shown in figures 3, 4, 5, and 6.

### CAUTION

**The 685SE actuator spring load will force the piston rod to extend out of the cylinder, and it can come into contact with the valve stem during actuator mounting.**

**If the valve stem is allowed to remain in the up position (towards the actuator) during mounting, it can interfere with the actuator mounting, possibly damage valve stem threads or bend the valve stem. Be sure the valve stem is pushed down (into the valve body), away from the actuator while mounting.**

**To avoid damaging the valve plug seating surfaces, do not rotate the valve plug while it is seated. Also avoid damage to the valve plug stem by careful use of tools during travel adjustment.**

For 685SE actuators only: It may be necessary to apply a temporary loading pressure to the bottom cylinder pressure connection to move the piston rod away from the valve stem during installation. If it is not possible to provide a temporary loading pressure, exercise caution when lowering the actuator over the valve stem to prevent damage to the valve stem or piston rod.

### ▲ WARNING

**When moving the piston rod with loading pressure applied, exercise caution to keep hands and tools out of the piston rod travel path. If the loading pressure is accidentally disconnected, personal injury and property damage is possible if something is caught between the piston rod and other control valve parts.**

1. For 685SE Actuators: Using the lifting points along the outside perimeter of the outer spring cartridge (key 23) attach appropriate rigging gear to both lifting points.  
For 685SR Actuators: Thread two lifting eyes into the free ports on the upper head (key 1) 180 degrees apart. Reference tables 4 and 5 for approximate weights of the actuator to select an appropriate lifting eye. Attach appropriate rigging gear to the lifting eyes.
2. Lower the actuator onto the valve bonnet.
  - a. For the 90.5 mm (3-9/16 inch) yoke boss: Slowly lower the actuator down onto the valve. As the yoke passes over the end of the valve stem, place the yoke locknut over the valve stem. Once the actuator is in place, screw the yoke locknut onto the valve bonnet and tighten.
  - b. For all other yoke bosses: Slowly lower the actuator down onto the valve. Once the actuator is in place, insert the bonnet-to-actuator bolts and tighten the hex nuts.
3. Turn the two stem locknuts (if present) all the way onto the valve stem thread.
4. Starting with the piston rod fully retracted, manually, or with air pressure, extend the piston rod to the specified valve travel.
5. Attach the stem connector (key 18), clamping the piston rod (key 17) to the valve stem. Be sure to also attach the feedback arm and travel indicator.
6. Cycle the actuator to check availability of desired total travel and that the valve plug seats before the cylinder reaches the end of its stroke. You can make minor travel adjustments, if necessary, by loosening the stem connector slightly, tightening the locknuts together, and (with the valve plug off the seat) screwing the stem connector either into or out of the stem connector by means of a wrench on the locknuts.

7. If the total travel is adequate, tighten the stem connector (key 18) securely, lock the stem locknuts (if present) against the connector, and adjust the indicator scale (key 22) on the yoke (key 21) to show valve plug position.
8. Provide a gauge, if necessary, to measure the pressure to the actuator. Make a final adjustment on the positioner to set the starting point of valve travel and to obtain full travel for the given instrument range.

## Handwheel Operation

If manual operation is required, the actuator should be equipped with a manual handwheel for sizes 10 to 26.

### CAUTION

**To avoid damage to actuator parts and difficult operation of actuator handwheels, open the bypass valve (key 66) before using a handwheel.**

The bypass assembly is furnished only when a handwheel actuator is specified. The bypass allows the pressure to equalize on either side of the piston, so that the manual actuator can be used to position the control valve. Flow through the bypass tubing is controlled by an angle needle valve, which is operated manually. This valve should be closed when air pressure is being used to operate the actuator.

Key numbers referenced in the following steps are shown in figures 2, 5, and 6. Refer to table 7 for handwheel specifications.

1. Open the bypass valve.
2. Rotate the handwheel (key 45) to position the override engage pin (key 38) with the hole in the stem connector (key 18). Use the engage pin control knob (key 33) to insert the override engage pin into the stem connector until it stops. Refer to figure 2 for engage pin control knob operation.

### Note

Depending on construction, the handwheel may have operation information stamped into the part. Always refer to steps 3 and 4 for operation information specific to push-down-to-close and push-down-to-open valves.

3. For a push-down-to-close valve: Rotate the handwheel (key 45) clockwise to close the valve and counterclockwise to open the valve.
4. For a push-down-to-open valve: Rotate the handwheel (key 45) counterclockwise to close the valve and clockwise to open the valve.
5. To disengage the manual handwheel, rotate the handwheel (key 45) to relieve any load placed on the override engage pin (key 38), and use the engage pin control knob (key 33) to remove the override engage pin from the stem connector (key 18). Refer to figure 2 for engage pin control knob operation.



Figure 2. Engage Pin Control Knob Operation

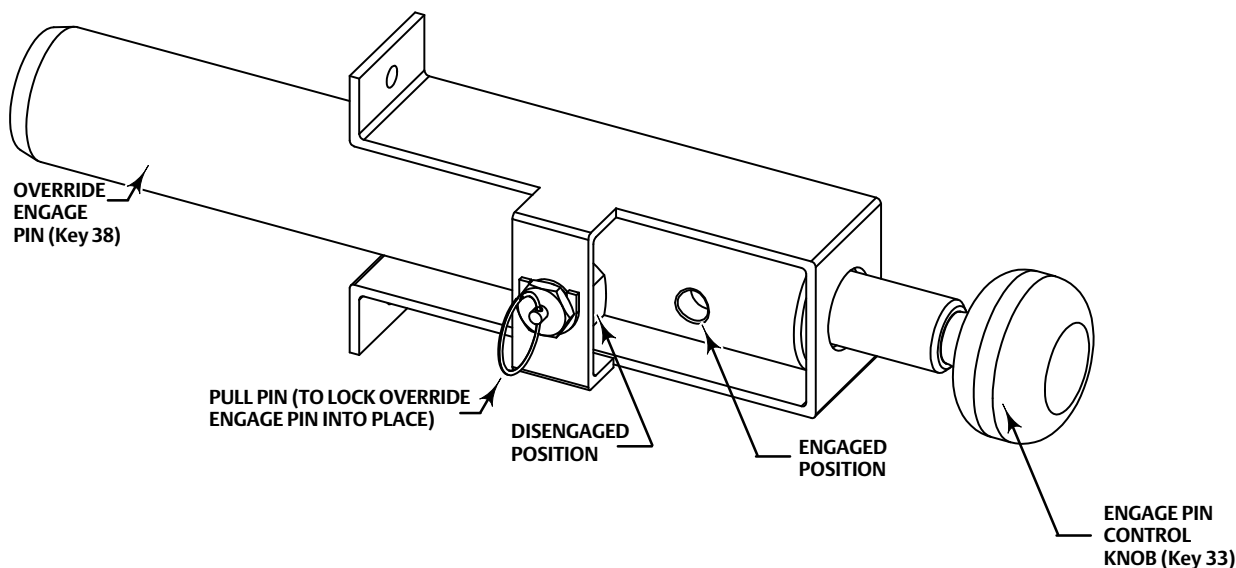

Table 7. Handwheel Specifications

ACTUATOR SIZE	OUTPUT THRUST		HANDWHEEL DIAMETER		TURNS PER mm OF TRAVEL	TURNS PER INCH OF TRAVEL	MAXIMUM RIM FORCE REQUIRED	
	N	lbs	mm	Inch			N	lbs
10 to 12	44482	10000	305	12	3.8	96	290	65
14 to 18	88964	20000	406	16	3.0	80	380	85
20 to 26	133447	30000	610	24	2.8	72	450	100

## Maintenance

### ⚠ WARNING

Avoid personal injury from sudden release of process pressure. Before performing any maintenance operations:

- Do not remove the actuator from the valve while the valve is still pressurized.
- Always wear protective gloves, clothing, and eyewear when performing any maintenance operations to avoid personal injury.
- Disconnect any operating lines providing air pressure, electric power, or a control signal to the actuator. Be sure the actuator cannot suddenly open or close the valve.
- Use bypass valves or completely shut off the process to isolate the valve from process pressure. Relieve process pressure on both sides of the valve. Drain the process media from both sides of the valve.
- Use lock-out procedures to be sure that the above measures stay in effect while you work on the equipment.
- The valve packing box may contain process fluids that are pressurized, *even when the valve has been removed from the pipeline*. Process fluids may spray out under pressure when removing the packing hardware or packing rings, or when loosening the packing box pipe plug.
- Check with your process or safety engineer for any additional measures that must be taken to protect against process media.

**⚠ WARNING**

The outer and inner spring cartridge (keys 23 and 57) contains a spring under compression. Do NOT attempt to dismantle any part of the spring cartridge without first consulting your local [Emerson sales office](#) or Local Business Partner to avoid personal injury.

Instructions are given below for complete disassembly of the actuator, seal replacement, and O-ring replacement. When inspection or repair is necessary, disassemble the actuator only as far as is required to accomplish the job. Key numbers referenced in the following steps are shown in figures 3, 4, 5, and 6.

## Actuator Removal

The following procedure is for the removal of the actuator from a valve.

For 685SE actuators only: It may be necessary to apply a temporary loading pressure to the bottom cylinder pressure connection to move the piston rod away from the valve stem during removal. If it is not possible to provide a temporary loading pressure, exercise caution when removing the actuator to prevent damage to the valve stem or piston rod.

1. Disconnect the actuator tubing from the pressure connections on the upper/lower head and outer spring cartridge (keys 1/9 and 23) and positioner.

**Note**

Refer to the appropriate instruction manual for any maintenance or adjustments that need to be made on the positioner.

**⚠ WARNING**

To avoid personal injury due to the sudden uncontrolled movement of parts, do not loosen the stem connector hex nuts when the stem connector has spring force applied to it.

2. Break the stem connection by removing hex nuts (key 62), studs (key 63) and lock washers (key 10) from the stem connector (key 18).
3. Depending on the yoke boss size, there is either a yoke locknut or bonnet-to-actuator bolting securing the actuator to the valve bonnet. Remove whichever is present.
4. For 685SE Actuators: Using the lifting points along the outside perimeter of the outer spring cartridge (key 23), attach appropriate rigging gear to both lifting points and lift the actuator away from the valve bonnet and stem.  
For 685SR Actuators: Thread two lifting eyes into the free ports on the upper head (key 1) 180 degrees apart. Reference tables 4 and 5 for approximate weights of the actuator to select an appropriate lifting eye. Attach appropriate rigging gear to both lifting eyes and lift the actuator away from the valve bonnet and stem.
5. Refer to the Actuator Mounting section of this manual for instructions on mounting and installing the actuator onto a valve.

## 685SE Seal and O-ring Replacement

The following procedure is for the replacement of the internal piston seals, bearing seals, and O-rings.

1. Remove the lower head (key 9) from the yoke (key 21) by removing hex head cap screws (key 20) and lock washers (key 10).
2. Loosen tie bolt hex nuts (key 11) in a crisscross pattern. Remove tie rod hex nuts and lock washers (key 10).
3. Remove lower head (key 9) from cylinder (key 4) and place the O-ring side down onto wooden blocks or other material that will not scratch or gouge the lower head.
4. Extract bearing assembly (keys 12, 13, 14, and 15) from lower head (key 9) by removing the bearing retaining ring (key 16).
5. Remove the piston wiper seal (key 15), O-ring (key 13), and quad seal (key 12) from the bearing (key 14).
6. Clean bearing (key 14) with a light degreaser, if needed.
7. Lightly grease the new O-ring (key 13) and quad seal (key 12), then install onto bearing (key 14). Without grease, install a new piston wiper seal (key 15) onto the bearing.
8. Reinstall bearing assembly (keys 12, 13, 14, and 15) into lower head (key 9) and secure in place with the bearing retaining ring (key 16).
9. Remove the O-ring (key 2) from the lower head (key 9) and clean the groove with a light degreaser.
10. Lightly grease the new O-ring (key 2) and install on lower head (key 9).
11. Remove tie bolts (key 3) from upper head (key 1).
12. Lift piston assembly (keys 5, 6, 7, 17, and 19) out from cylinder (key 4) and place on a flat surface.
13. Remove the wear ring (key 6) and quad seal (key 7) from the piston (key 5).
14. Thread locking compound is applied to the threads by the manufacturer during initial assembly. As a result, disassembly will require heating to loosen the thread locking compound. To remove the piston rod O-ring (key 19), heat the piston assembly using a torch and unthread the piston rod (key 17) from the piston (key 5).
15. After the piston rod (key 17) has completely cooled, remove the piston rod O-ring (key 19). Clean the piston rod O-ring groove with a light degreaser. Lightly grease a new piston rod O-ring and install onto the piston rod.
16. Reinstall piston rod (key 17) onto piston (key 5) using thread locking compound.
17. Clean piston seal grooves. Install new lightly greased quad seal (key 7) onto piston (key 5).
18. Without grease, trim to length and then install a new wear ring (key 6).
19. Lift cylinder (key 4) vertically and place on a flat surface. Take extra precaution to avoid scratching or gouging the inner diameter of the cylinder.
20. Remove O-ring (key 2) from the upper head (key 1) and clean the seal groove. Install lightly greased new O-ring into upper head seal groove.
21. Install cylinder (key 4) onto upper head (key 1), making sure the O-ring (key 2) does not move out of its groove.
22. Carefully install the piston assembly (keys 5, 6, 7, 17, and 19) into cylinder (key 4), making sure all seals and O-rings stay in place on the outside diameter of the piston (key 5).
23. Install tie bolts (key 3) into upper head (key 1).
24. Carefully install lower head (key 9) onto cylinder (key 4), taking care not to damage threads on the tie bolts (key 3). Be sure the O-ring (key 2) is in place during this step.
25. Install lock washers (key 10) and tie bolt hex nuts (key 11) onto tie bolts (key 4). Torque in a crisscross pattern according to table 8.
26. Refer to the Actuator Mounting section of this manual for instructions on mounting and installing the actuator onto a valve.

Table 8. Tie Bolt Torque

BOLT DIAMETER	TORQUE	
	N • m	lbf • ft
1/4-20	8	6
5/16-18	15	11
3/8-16	26	19
7/16-14	39	29
1/2-13	60	44
9/16-12	84	62
5/8-11	115	85
3/4-10	198	146
7/8-9	313	231
1-8	445	328
1-1/8-7	662	488

## 685SR Seal and O-ring Replacement

The following procedure is for the replacement of the internal piston seals, bearing seals, and O-rings.

1. Complete Actuator Removal procedures above. Using the same rigging and lifting points as in the Actuator Removal section, place the actuator upright with the yoke (key 21) flat against the ground. Place either a flat piece of plywood or cloth under the yoke to protect against damage. Using straps, secure the actuator to a solid structure to prevent it from falling over.
2. Loosen tie bolt hex nuts (key 11) in a crisscross pattern. Remove tie rod hex nuts and lock washers (key 10).
3. Using the same lifting eyes as in the Actuator Removal procedure, lift or hoist the upper head (key 1) off of the cylinder (key 4). Place the upper head onto wooden blocks or other material that will not cause damage with the O-ring side facing up.
4. Remove O-ring (key 2) from the upper head (key 1) and clean the seal groove. Install lightly greased new O-ring into upper head seal groove.
5. Remove tie bolts (key 3) from lower head (key 9).
6. Thread a suitable lifting eye into the free port on the top of the piston rod (key 17).
7. Lift or hoist the piston assembly (keys 5, 6, 7, 17, and 19) out from cylinder (key 4) and place on a flat surface upside down.
8. Remove the wear ring (key 6) and quad seal (key 7) from the piston (key 5).
9. Thread locking compound is applied to the threads by the manufacturer during initial assembly. As a result, disassembly will require heating to loosen the thread locking compound. To remove the piston rod O-ring (key 19), heat the piston assembly using a torch and unthread the piston rod (key 17) from the piston (key 5).
10. After the piston rod (key 17) has completely cooled, remove the piston rod O-ring (key 19). Clean the piston rod O-ring groove with a light degreaser. Lightly grease a new piston rod O-ring and install onto the piston rod.
11. Reinstall piston rod (key 17) onto piston (key 5) using thread locking compound.
12. Clean piston seal grooves. Install new lightly greased quad seal (key 7) onto piston (key 5).
13. Without grease, trim to length and then install a new wear ring (key 6).
14. Lift cylinder (key 4) vertically and place on a flat surface. Take extra precaution to avoid scratching or gouging the inner diameter of the cylinder.
15. Remove the O-ring (key 2) from the lower head (key 9) and clean the groove with a light degreaser.
16. Lightly grease the new O-ring (key 2) and install on lower head (key 9).
17. Extract bearing assembly (keys 12, 13, 14, and 15) from outer spring cartridge (key 23) by removing the bearing retaining ring (key 16).

18. Remove the piston wiper seal (key 15), O-ring (key 13), and quad seal (key 12) from the bearing (key 14).
19. Clean bearing (key 14) with a light degreaser, if needed.
20. Lightly grease the new O-ring (key 13) and quad seal (key 12), then install onto bearing (key 14). Without grease, install a new piston wiper seal (key 15) onto the bearing.
21. Reinstall bearing assembly (keys 12, 13, 14, and 15) into outer spring cartridge (key 23) and secure in place with the bearing retaining ring (key 16).
22. Install cylinder onto lower head (key 9), making sure the O-ring (key 2) does not move out of its groove.
23. Carefully install piston assembly (keys 5, 6, 7, 17, and 19) into the cylinder (key 4) using the lifting eye previously used for removal. Ensure all seals and O-rings stay in place on the outside diameter of the piston (key 5) during installation.
24. Install tie bolts (key 3) into lower head (key 9).
25. Carefully install upper head (key 1) onto cylinder (key 4) using the lifting eyes previously used for removal. Take care not to damage tie bolt (key 3) threads and ensure that the O-ring (key 2) is in place during this step.
26. Install lock washers (key 10) and tie bolt hex nuts (key 11) onto tie bolts (key 4). Torque in a crisscross pattern according to table 8.
27. Refer to the Actuator Mounting section of this manual for instructions on mounting and installing the actuator onto a valve.

## Parts Ordering

When corresponding with your [Emerson sales office](#) or Local Business Partner about this equipment, refer to the serial number found on the actuator nameplate.

### **⚠ WARNING**

**Use only genuine Fisher replacement parts. Components that are not supplied by Emerson Automation Solutions should not, under any circumstances, be used in any Fisher valve, because they may void your warranty, might adversely affect the performance of the valve, and could cause personal injury and property damage.**

## Parts Kits

Includes all soft seals and O-rings required for seal and O-ring replacement in standard operating temperature constructions. Refer to figures 3 and 4.

KIT CONTENTS	ACTUATOR SIZE	PART NUMBER		
		Standard Temperature	Low Temperature	High Temperature
Piston Rod Wiper Seal, Key 15 Bearing O-ring, Key 13 Bearing Quad Seal, Key 12 Piston Rod O-ring, Key 19 Piston Wear Ring, Key 6 Piston Quad Seal, Key 7 Upper/Lower Head O-ring, Key 2 Upper/Lower Head O-ring, Key 2 685SE/685SR Actuator Grease, Key 100	10	R685X000252	R685X000272	R685X000292
	12	R685X000012	R685X000092	R685X000172
	14	R685X000022	R685X000102	R685X000182
	16	R685X000032	R685X000112	R685X000192
	18	R685X000042	R685X000122	R685X000202
	20	R685X000052	R685X000132	R685X000212
	22	R685X000062	R685X000142	R685X000222
	24	R685X000072	R685X000152	R685X000232
	26	R685X000082	R685X000162	R685X000242
	28	R685X000262	R685X000282	R685X000302

## Parts List

### Note

Contact your [Emerson sales office](#) or Local Business Partner for Part Ordering information.

## Common Parts (figures 3, 4, 5, and 6)

Key	Description	
1	Upper Head	
2*	Upper/Lower Head O-ring	see parts kit
3	Tie Bolt	
4	Cylinder	
5	Piston	
6*	Piston Wear Ring	see parts kit
7*	Piston Quad Seal	see parts kit
9	Lower Head	
10	Lock Washer	
11	Tie Bolt Hex Nut	
12*	Bearing Quad Seal	see parts kit
13*	Bearing O-ring	see parts kit
14	Bearing	
15*	Piston Rod Wiper Seal	see parts kit
16	Bearing Retaining Ring	
17	Piston Rod	
18	Stem Connector	
19*	Piston Rod O-ring	see parts kit
20	Hex Head Cap Screw	
21	Yoke	
22	Travel Scale	
23	Outer Spring Cartridge	
57	Inner Spring Cartridge	
58	Spring Cartridge Wear Ring	
61	Spring	
62	Stem Connector Hex Nut	
63	Stem Connector Stud	
100*	685SE/SR Actuator Grease (10 ounce tube)	see parts kit (19B0808X222)

## Manual Handwheel Parts (figures 5 and 6)

Key	Description
24	ACME Thrust Shaft
25	Override Guide Shaft
26	Worm Gear
27	Thrust Shaft Upper Bushing
28	Thrust Shaft Bushing
29	Thrust Bearing
30	Thrust Guide Block
31	Engage Pin Guide
33	Engage Pin Control Knob
35	Socket Head Cap Screw
37	Key
38	Override Engage Pin
39	Position Indicator
40	All Thread Stud
42	Yoke Adaption Bracket
45	Handwheel
46	Helix Housing Cap O-ring
47	Helix Gear Shaft Bushing
48	Helix Gear Bearing
49	Helix Worm Gear Housing
50	Helix Worm Gear
52	Helix Shaft Wiper Seal
53	Helix Worm Gear Shaft
54	Helix Gear Housing Cap
55	Lock Washer
56	Pointer
64	Yoke Adaption Bracket Hex Nut
65	Yoke Adaption Bracket Stud

Figure 3. Fisher 685SE Piston Actuator

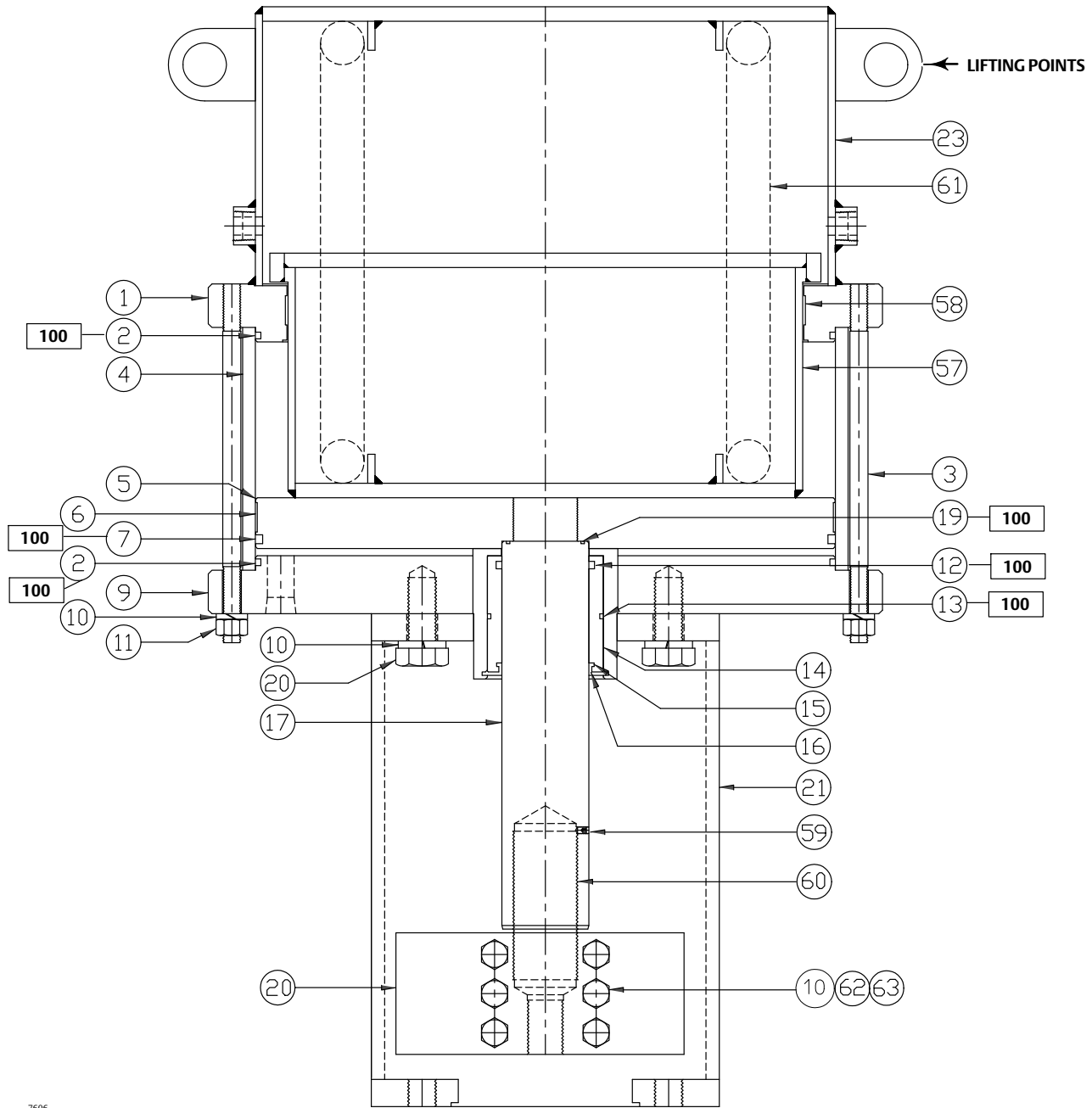
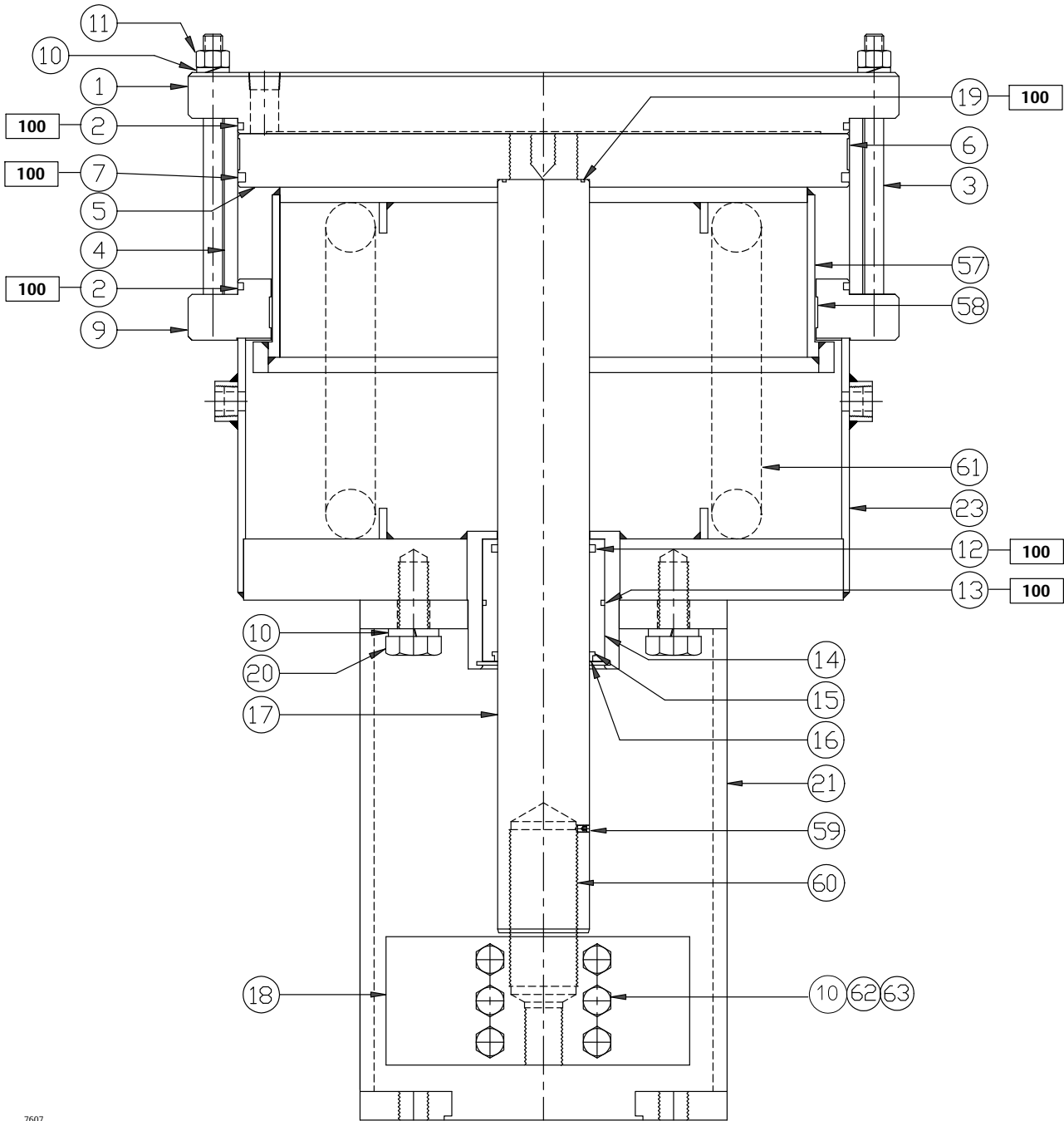

Figure 4. Fisher 685SR Piston Actuator



7607



Figure 5. Fisher 685SE Piston Actuator with Manual Handwheel

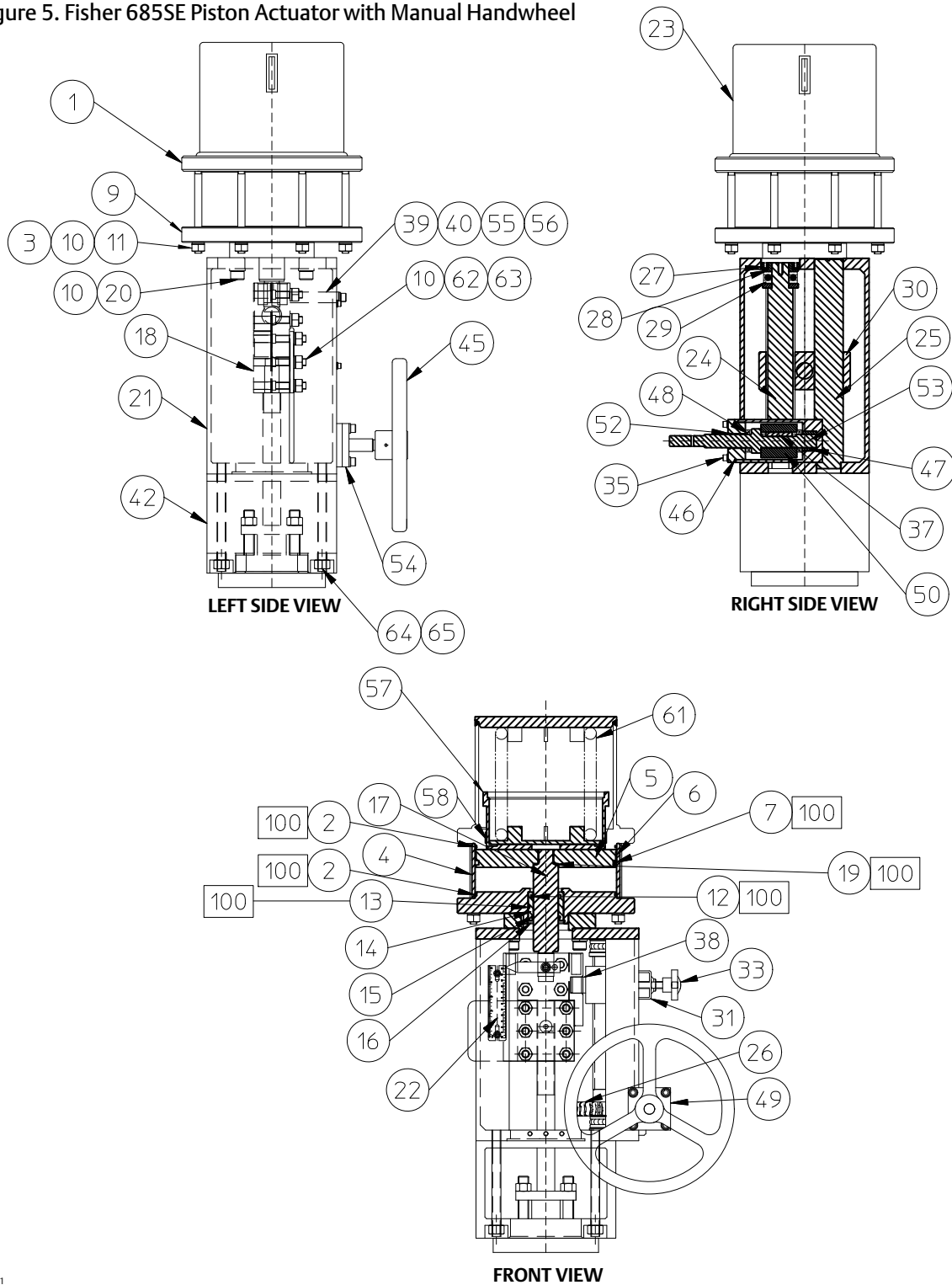
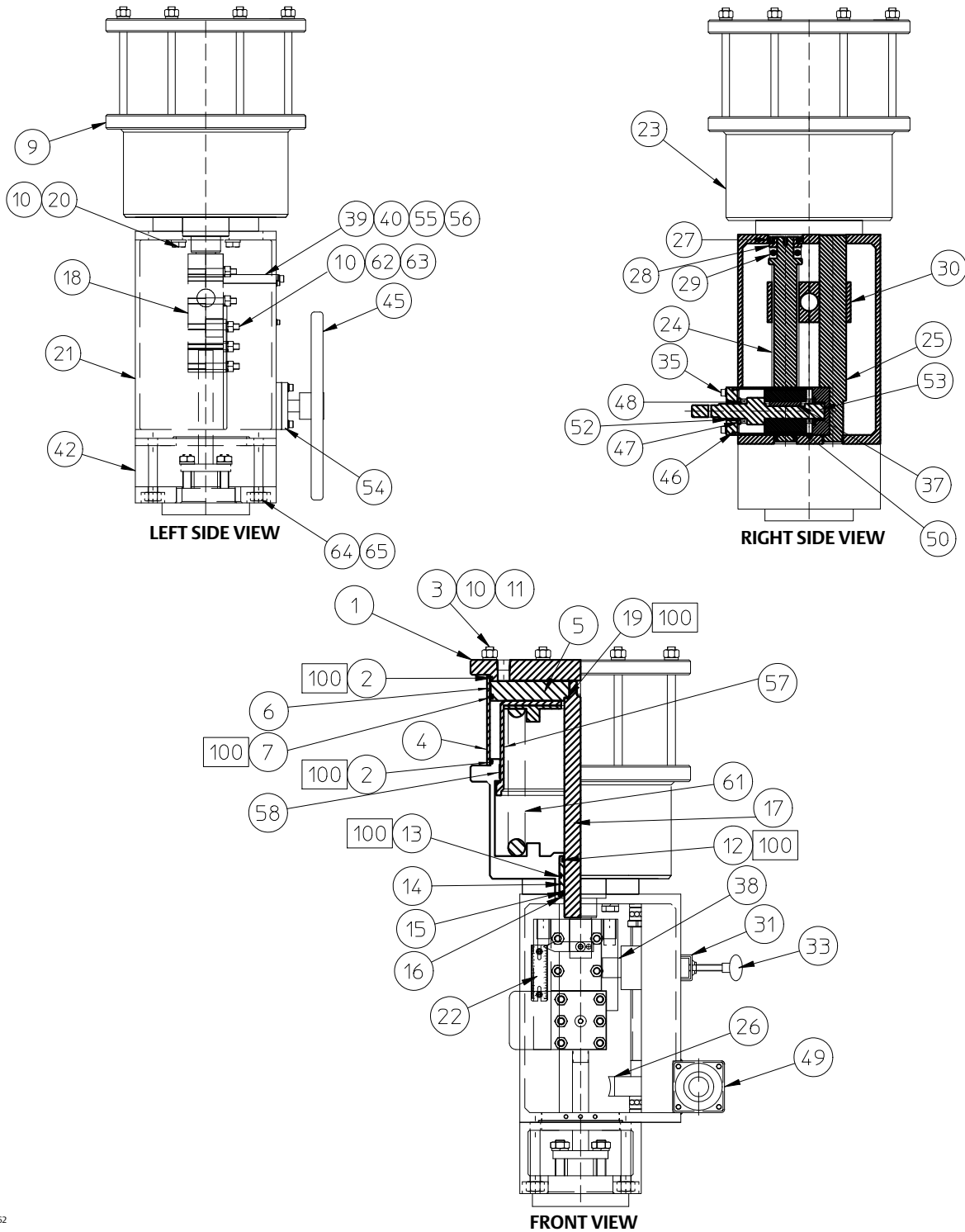

Figure 6. Fisher 685SR Piston Actuator with Manual Handwheel



S24862



Neither Emerson, Emerson Automation Solutions, nor any of their affiliated entities assumes responsibility for the selection, use or maintenance of any product. Responsibility for proper selection, use, and maintenance of any product remains solely with the purchaser and end user.

Fisher, easy-e, and FIELDVUE are marks owned by one of the companies in the Emerson Automation Solutions business unit of Emerson Electric Co. Emerson Automation Solutions, Emerson, and the Emerson logo are trademarks and service marks of Emerson Electric Co. All other marks are the property of their respective owners.

The contents of this publication are presented for informational purposes only, and while every effort has been made to ensure their accuracy, they are not to be construed as warranties or guarantees, express or implied, regarding the products or services described herein or their use or applicability. All sales are governed by our terms and conditions, which are available upon request. We reserve the right to modify or improve the designs or specifications of such products at any time without notice.

Emerson Automation Solutions  
Marshalltown, Iowa 50158 USA  
Sorocaba, 18087 Brazil  
Cernay, 68700 France  
Dubai, United Arab Emirates  
Singapore 128461 Singapore

[www.Fisher.com](http://www.Fisher.com)

---

