

January 2015

# Throttle Valve - Transmission

## SUMMARY

Introduction	1
Description	1
Characteristics	2
Labelling	2
Dimensions and Weights	3
Operation	4
Installation	4
Commissioning	5
Maintenance	6
Spare Parts	10

## INTRODUCTION

The BLE throttle valve functions as a bypass on transmission pressure reducing stations up to 100 bar.

The BLX is equipped with an integral slam-shut valve Type OS2 used to cut off pressure flow in the case of outlet overpressure.

## DESCRIPTION

The **BLE** version consists of:

- A body (Type E body) with removable orifice, closed with a cap also serving as a valve guide.
- A balanced valve plug, opened by fluid flow, linear characteristic.
- A valve plug/orifice nitrile disc plug, removable and tight shutoff.
- A valve plug guide with plastic rings and manual handwheel.



**Figure 1.** Type BLE-BLX Throttle Valve

- The bouton serves as an opening indicator.

The **BLX** version, equipped with slam-shut Type OSE with release relay Type OS2:

- A body (Type X body) including an inferior opening for lodging the slam-shut.

The slam-shut includes:

- A valve plug/orifice assembly with connecting part.
- A release relay Type OS2 including a mechanism box (BM and a safety manometric box (BMS).

The **BLE** and **BLX** are in conformity with the Pressure Equipment Directive PED 97/23/CE and are classified in Category IV.

# BLE - BLX

## CHARACTERISTICS

Table 1. Types BLE and BLX Trottle Valve Characteristics

OPERATING PRESSURE			SLAM-SHUT VALVE (BLX ONLY)		
LCC body	PS	100 bar	Response time	AG	< 1 s
WCB-20 body		96,7 bar	Accuracy		2.5
Maximum differential		Equal to PS			
OPERATING TEMPERATURE			Setpoint range	Pt	0,010 / 100 bar
LCC body	TS	- 30° / 71°C	Resetting	Manually after fault rectification	
WCB-20 body		- 20° / 71°C	Position indicator	On the mechanism box	
Fluid	Groups 1 and 2 according to PED 97/23/CE, 1 <sup>st</sup> and 2 <sup>nd</sup> family gas according to EN 437, or other gases (compressed air, nitrogen). The gas must be noncorrosive, clean (filtration on inlet side necessary) and dry.				

B69A

Table 2. Flow Coefficients

FLOW COEFFICIENT			
DN	25	50	80
Qf	230	970	2150
Cg	450	1880	4170
C1	35		

B69B

## Materials

Body	Steel
Bonnet	Steel
Screw holder	Bronze
Orifice	Stainless steel
Valve plug	Steel
Disc plug	Nitrile

## Connections

Inlet / Outlet: ISO PN 100 B (ANSI 600 RF)  
 ISO PN 50 B (ANSI 300 RF)  
 ISO PN 20 B (ANSI 150 RF)  
 Other connections available (contact factory)  
 ISO PN 16 B, 25 B, 40 B

## LABELLING

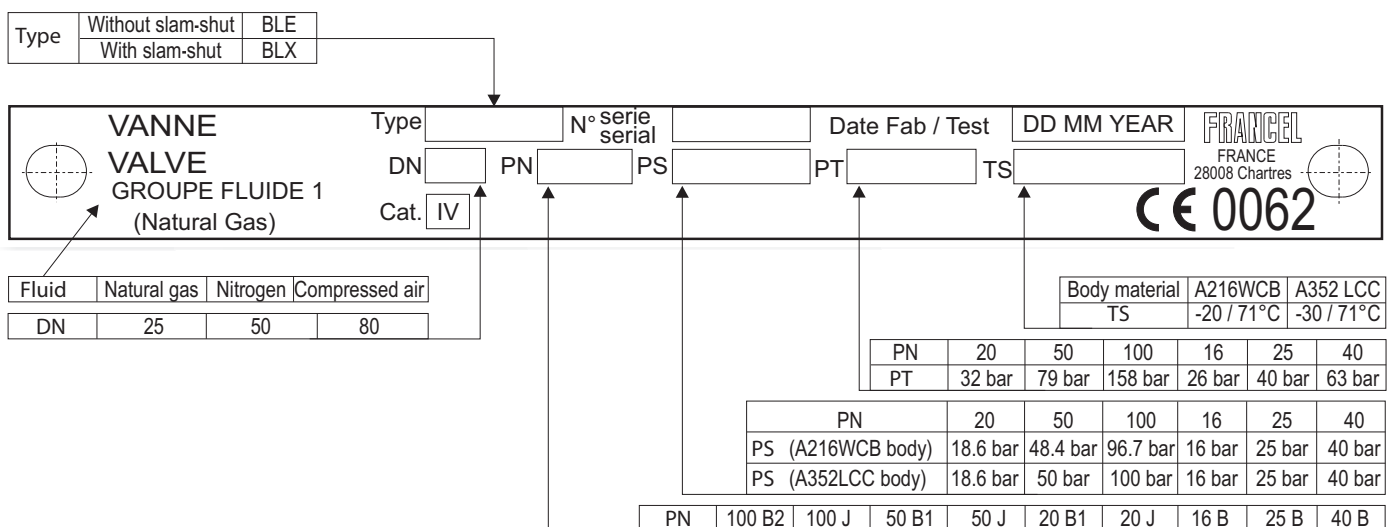

B70

Figure 2. Label for Types BLE and BLX Trottle Valve

## DIMENSIONS AND WEIGHTS

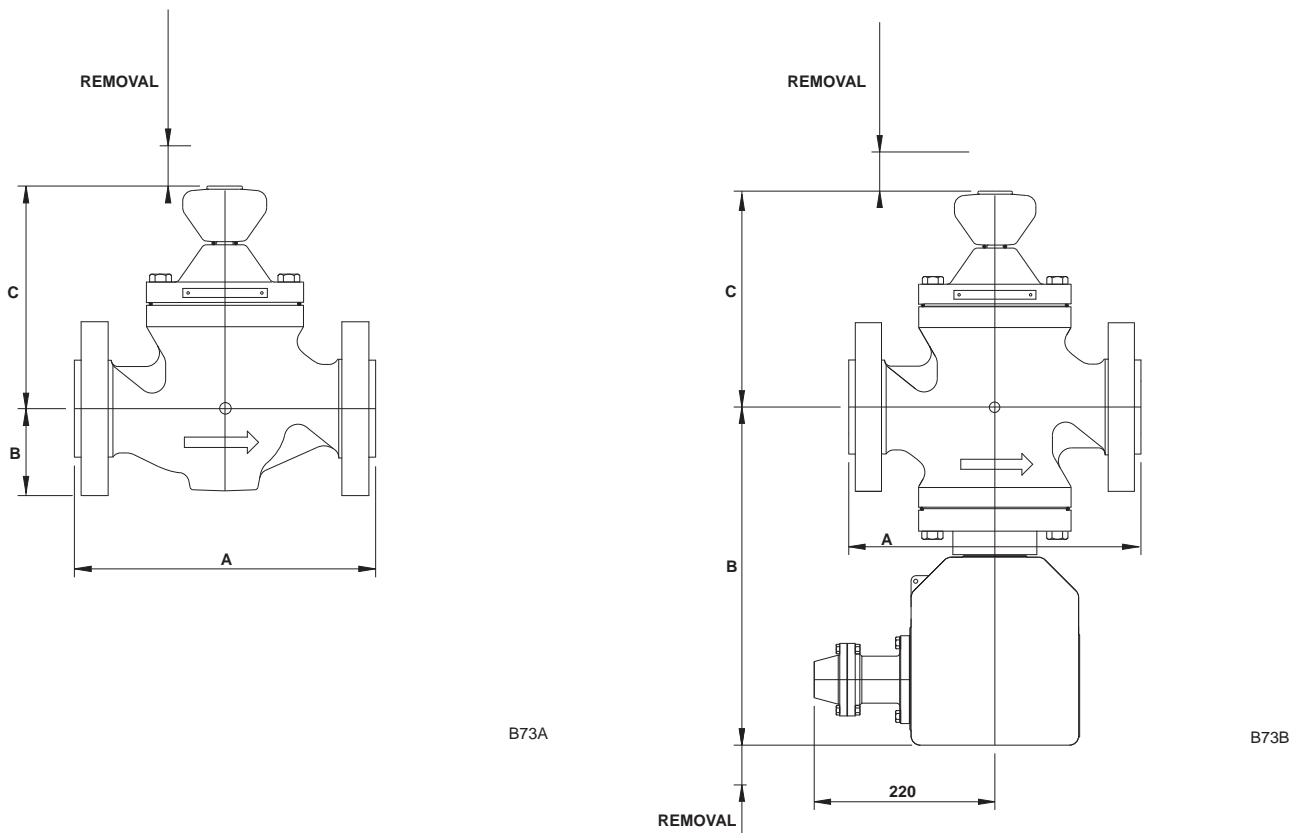

Figure 3. Types BLE and BLX Trottle Valve Dimensions

Table 3. Types BLE-BLX Trottle Valve Dimensions and Weights

DN	PN	DIMENSIONS BLE (WITHOUT SLAM-SHUT) AND BLX (WITH SLAM-SHUT)						WEIGHT (kg)	
		A	B		C		Removal	BLE	BLX
			BLE	BLX	BLE	BLX			
25	20	185	54	315	183	196	55	12	20
	50	197	62					13	21
	100	210	62					14	22
50	20	254	76	330	196	213	75	22,5	36
	50	267	83					24,5	38
	100	287	83					26,5	40
80	20	298	95	361	223	241	95	43	57
	50	318	105					49	63
	100	337	105					51	65

B74

# BLE - BLX

## OPERATION

### BLE or BLX

The BLE throttle valve is a balanced plug type, opened by pressure flow.

The opening control is manually performed by a torque handwheel (approx. 4 N·m). 1 handwheel turn = 2 mm travel.

Tight shutoff is achieved by a nitrile disc plug situated on the valve plug. The disc plug and orifice are easily replaced.

The opening control is progressive to start and then linear. In closed position, an O-ring situated below the handwheel protects the control screw for exterior corrosion.

A rotation of 1/8 turn after contact with the valve plug / orifice is sufficient to assure tight shutoff.

**Table 4.** Opening Control Measurements

DN	NO. OF TURNS	TRAVEL
25	4	8
50	7.5	15
80	11.5	23

### Slam-Shut (BLX)

The pressure of the zone to be protected (in general the pipeline, outlet side of the regulator and after the slam-shut) reacts on the safety manometric box (BMS).

If the pressure rises above the set range, the release relay releases the valve plug. Due to the action of the closing spring and the fluid (trying to close), the valve plug closes on the orifice.

The gas flow is obstructed until the fault has been corrected and the mechanism box manually rearmed.

Equal pressure balance on inlet and outlet sides are necessary to reopen the valve plug.

The mechanism box is rearmed after opening the internal bypass.

Rearming and balancing are achieved at the same time.

## INSTALLATION

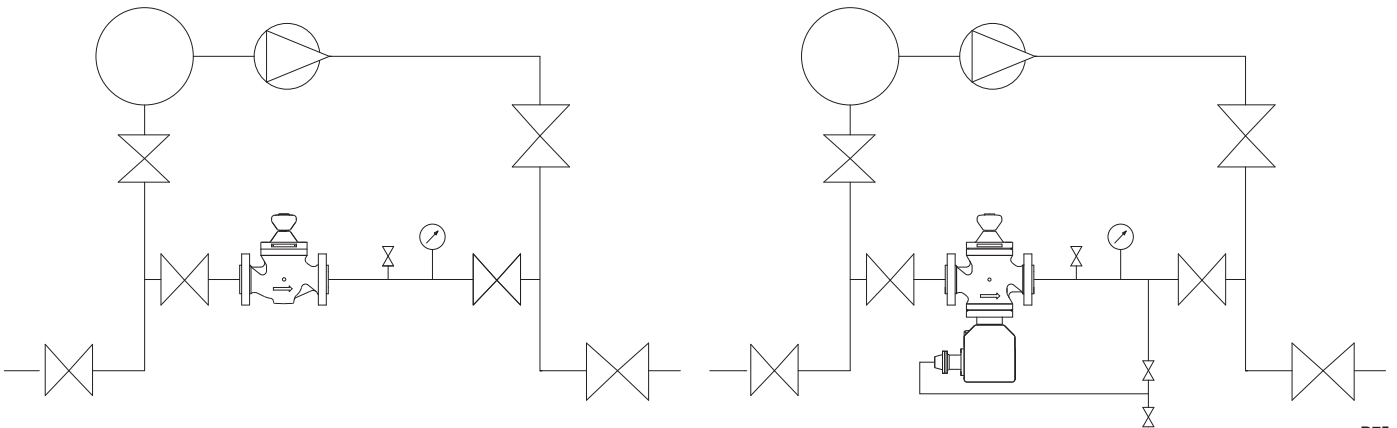

**Figure 5.** Type BLE-BLX Installation

B75

**Respect the direction of the fluid flow and the position of the valve (fluid opening the throttle valve plug).**

BLX version (with slam-shut, connect the safety manometric box impulse).

### WARNING

All interventions on the equipment should only be performed by qualified and trained personnel.

BLE version, the valve is to be installed on horizontal or vertical pipeline with the control handwheel in a top, bottom or lateral position.

### WARNING

BLX version, the valve is to be installed on a horizontal pipeline with the control handwheel in a top or bottom position.

Install according to direction of fluid flow (arrow). Opened by fluid flow.

When assembling with adjacent elements care must be taken not to create pressure force on the body and the assembling elements (bolts, O-rings, flanges) should be compatible with the geometry and working conditions of the equipment.

If the case arises a support must be used to avoid pressure force on the body (a support can be installed under the flanges).

No modification should be made to the structure of the equipment (drilling, grinding, soldering...).

Verify that the inlet side is protected by an appropriate device(s) to avoid exceeding the limits of utilization (PS, TS).

Verify that the limits of utilization correspond to the appropriate operating conditions.

BLX version, verify that the safety manometric box (BMS) and spring correspond to the appropriate operating conditions on the outlet side of the throttle valve.

The equipment should not receive any type of shock, especially the handwheel and release relay.

Fire, seismic and lightning are not taken into consideration in standard regulators. If required, a special product selection and/or specific calculations may be supplied according to specific requirements.

The user should verify or carry out a protection adapted to the environment.

- BLE inlet valve  
→ Closed
- BLE throttle valve  
→ Closed

#### Positions before commissioning

- Expansion line(s)  
→ Isolated
- BLE inlet valve  
→ Open

The equipment is ready for commissioning.

#### Commissioning

- BLE throttle valve  
→ **Open slowly observing the manometer outlet side of the station.**

The equipment is commissioned.

### Type BLX (with slam-shut)

#### Preliminary Verifications

##### Departure positions

- Inlet and outlet station valves  
→ Open
- Expansion line(s)  
→ Operating
- BLX inlet valve  
→ Closed
- BLX throttle valve  
→ Closed
- BLX slam-shut  
→ Closed
- Impulse line isolation valve  
→ Closed
- Impulse line atmospheric valve  
→ Opened

#### Slam-shut Setpoint Verification

Using the atmospheric valve, inject a pressure equal to the pressure required for the regulator.

- 1<sup>st</sup> release relay stage (BM)  
→ Set (Stage 1)

## COMMISSIONING



### WARNING

All interventions on the equipment should only be performed by qualified and trained personnel.

### Type BLE (without slam-shut)

#### Preliminary Verifications

##### Start-up positions

- Inlet and outlet station valves  
→ Open
- Expansion line(s)  
→ Operating

# BLE - BLX

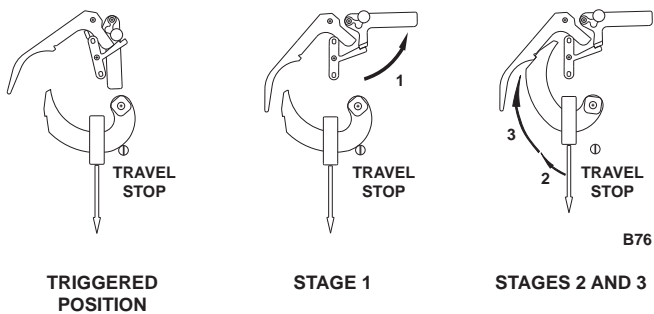

Figure 6. Slam-Shut Positions

- Slam-shut valve plug
  - Open (Stages 2 and 3)
  - Progressively increase the pressure to reach tripping
  - Adjust the setting if necessary (see D103683X012-OS2-IM manual)

**Note the setpoint value on the equipment** or mark it on a commissioning document.

## Positions before commissioning

- Expansion line(s)
  - Isolated
- Impulse line isolation valve
  - Open
- Impulse line atmospheric valve
  - Closed
- Valve plug
  - Closed

**The equipment is ready for commissioning.**

## Commissioning

- BLX inlet valves
  - Open slowly
- 1<sup>st</sup> release relay stage
  - Set (Stage 1)
- Slam-shut internal bypass
  - Open slowly (Stage 2)
- Slam-shut valve plug
  - Open (Stage 3)
- Outlet valve
  - Open slowly
- BLX throttle valve
  - Open slowly observing the manometer outlet side of the station.

**The equipment is commissioned.**

*It is recommended to seal the release relay.*

## MAINTENANCE

### Servicing Check

#### Recommended frequency:

- **BLE - BLX** Once every 2 years for the throttle valve
- **BLX** Twice yearly minimum for the slam-shut

#### Verification:

- **BLE - BLX** Verification manual opening of the valve  
Tight shutoff of the throttle valve plug
- **BLX** Triggering and setpoint verification  
Valve plug tight shutoff

#### Departure positions

- Inlet valve → Closed
- Outlet valve → Closed
- Servicing valve → Closed
- Throttle valve (BLE, BLX) → Closed
- Slam-shut (BLX) → Open

#### Tight shutoff verification of the throttle valve (BLE, BLX)

- Inlet valve → Open
- Servicing valve → Open
- Servicing valve → Closed
- Throttle valve → Open very slowly and close when outlet regulator pressure is achieved
- Throttle valve Observe the evolution of outlet pressure

#### Verification of tight shutoff and slam-shut triggering (BLX)

- Throttle valve → Open very slowly to slam-shut set point without exceeding permitted limits

**Table 5.** Troubleshooting for Type BLE Throttle Valve

SYMPTOMS	CAUSE	ACTIONS
If outlet pressure increases	Leak in the throttle valve plug	Control the throttle valve plug Control the throttle orifice <b>or contact after-sales</b>
If outlet pressure is constant	Throttle valve plus is tight shutoff	Contact after-sales

**Table 6.** Troubleshooting for Type BLX Throttle Valve

If the slam-shut valve plug will not close	Operation faulty	Control the release relay Control the slam-shut valve plug or contact after-sales
If the slam shut valve plug closes	Operation correct	
Observe the evolution of the outlet pressure (control tightness)		
If the slam-shut valve plug outlet pressure decreases	External leak	Locate and seal the leak or contact after-sales
If the slam-shut valve plug outlet pressure is constant		Purge the outlet side of the throttle valve
If the outlet pressure increases	Internal leak	<i>Control the slam-shut valve plug</i> <i>Control the orifice</i> <i>Control the internal bypass</i> <i>or contact after-sales</i>
If the outlet pressure is constant	Valve plug is tight shutoff	

**Table 7.** Tools and General Information for Tightening

TIGHTENING SCREW 1 (BONNET 2 + CONNECTING PART 18)			
DN	Dimensions	Spanner (inch)	Torque (N•m)
25	9/16-12 x 1 3/4	13/16	110
50	1/2-13 x 1 1/2	3/4	110
80	5/8-11 x 1 3/4	15/16	175

TIGHTENING BYPASS 19	
DN	Torque (N•m)
25	14
50	
80	20

ITEM	TIGHTENING	
	Dimensions	Torque (N•m)
4	M4 + M5	4
	M6	6
15	M8	15

# BLE - BLX

---

## MAINTENANCE

### Disassembly of the Throttle Valve

#### Recommended frequency:

- Every 4 to 6 years (or less depending on operating conditions)

#### Verification:

- Condition of O-rings, valve disc plug, lubrication

#### Replacement:

- O-rings, valve disc plug

#### Tools:

- 2 flat spanners according to DN
- Six-sided spanners numbers 3, 4, 5, 6, 13, 24
- Box spanner numbers 13, 19

### Precautions Before Disassembly

- Close inlet and outlets valves.
- Valve plug open  
*Open fully the valve plug by turning the knob (key 9) until metal/metal contact is made with the valve plug (key 13) on the bonnet (key 2).*
- **Bleed off outlet pressure**
- **Bleed off inlet pressure**

#### Type BLE (without slam-shut)

- Unscrew screws (key 1) from bonnet (key 2).
- Remove bonnet/valve plug assembly.
- Remove orifice (key 3).



## WARNING

**With knob (key 9) in bottom position (equipment turned upside down) the orifice (key 3) descends with the bonnet/valve plug assembly and is just centered by the columns on the edge of the orifice (key 3).**

- Unscrew screws (key 4) from pad retainer (key 5) (only one for DN 25).
- Remove valve plug (key 6).

- Remove the valve plug support (key 7) (wrench DN 25 and six-sided spanner for DN 50 and 80).
- Unscrew safety nut (key 8) while holding knob (key 9).
- Recover the lower stop part (key 10) (thick washer, cage, thin washer) and fully unscrew the knob (key 9) to remove the knob (key 9)/control stem (key 11) assembly.
- Remove the valve plug plate (key 13).
- Recover the upper stop part (key 12) (thin washer, cage, thick washer).

#### Type BLX (with slam-shut)

As well as above operations

- Unscrew impulse connector IS.
- Remove cover (key 14) from BM.
- Unscrew fixing screws (key 15).
- Remove holding pin.
- Remove BM.
- Unscrew screw (key 1) from connecting part (key 16).
- Remove connecting part (key 16).
- Remove spring (key 17) and valve plug (key 18).
- Unscrew bypass (key 19).

Removing the orifice (not recommended) requires a special extraction tool.

### Reassembly

#### Type BLE (without slam-shut)

- Perform above operations in reverse order (respect tightening torques).
- Replace O-rings at every disassembly.
- Lubricate screws before tightening.
- Lightly lubricate O-rings (silicone grease).
- Lubricate the stem (key 11) in the rim (key 20) (molybdenum graphite grease).
- Precaution must be taken concerning the passage of the valve plug over the segments.



## Type BLX (with slam-shut)

As well as above operations

- Lightly lubricate the O-rings (silicone grease) except for the valve plug O-ring.
- Precaution must be taken concerning the passage of the valve plug over the segments.
- Lightly lubricate the stem (silicone grease).
- Lubricate the release relay mechanism (yoke and bolt (molybdenum graphite grease).
- Lubricate the BMS spring (molybdenum graphite grease).
- A special tool is required for reassembling a new orifice.

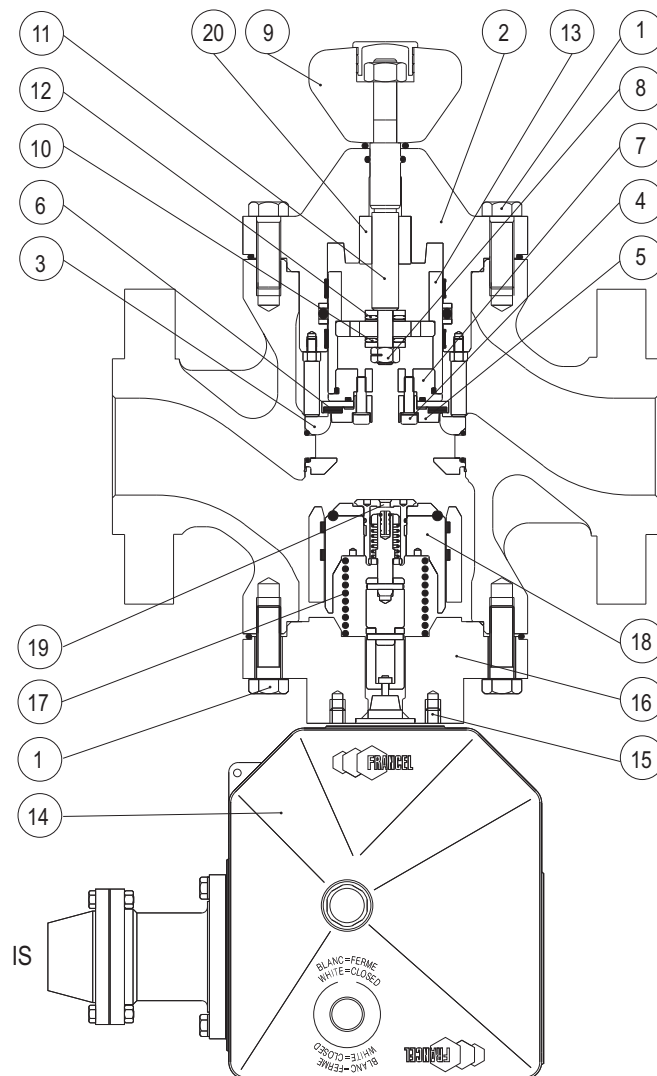

Figure 7. Type BLE-BLX Maintenance Schematic

# BLE - BLX

## SPARE PARTS

Release relay Type OS2: see D103683X012-OS2-IM manual

**Table 8. BLE-BLX Spare Parts**

ITEM	DESCRIPTION	QUANTITY	DN 25		DN 50		DN 80	
			BLE	BLX	BLE	BLX	BLE	BLX
1	O-ring	1	400 513					
2	O-ring	1	19B2838X012		18B2124X012		18B8514X012	
3	Guide ring	2	GD27409X012		GD27276X012		GD27281X012	
4	Anti-extrusion washer	2	GD19453X012		GD19469X012		GD19217X012	
5	O-ring	1	400 524		400 535		400 543	
6	O-ring	1	400 104		400 098		400 107	
7	O-ring	1	400 105		400 101		400 108	
8	O-ring		400 106		400 005		400 109	
9	Valve plug	1	GD28090X012		GD28091X012		GD28092X012	
10	Bypass	1		180 977		180 977		180 977
11	Valve plug O-ring	1		400 257		400 263		400 258
12	Segment	2		401 950		401 951		401 952
	Packing gland « Kit »			197 395		197 395		197 395
	Set of O-rings*	-	197 839		197 840		197 841	
	Spare parts kit**		197 801		197 802		197 803	

\*Including all O-rings.

\*\*Including all commissioning spares and O-rings.

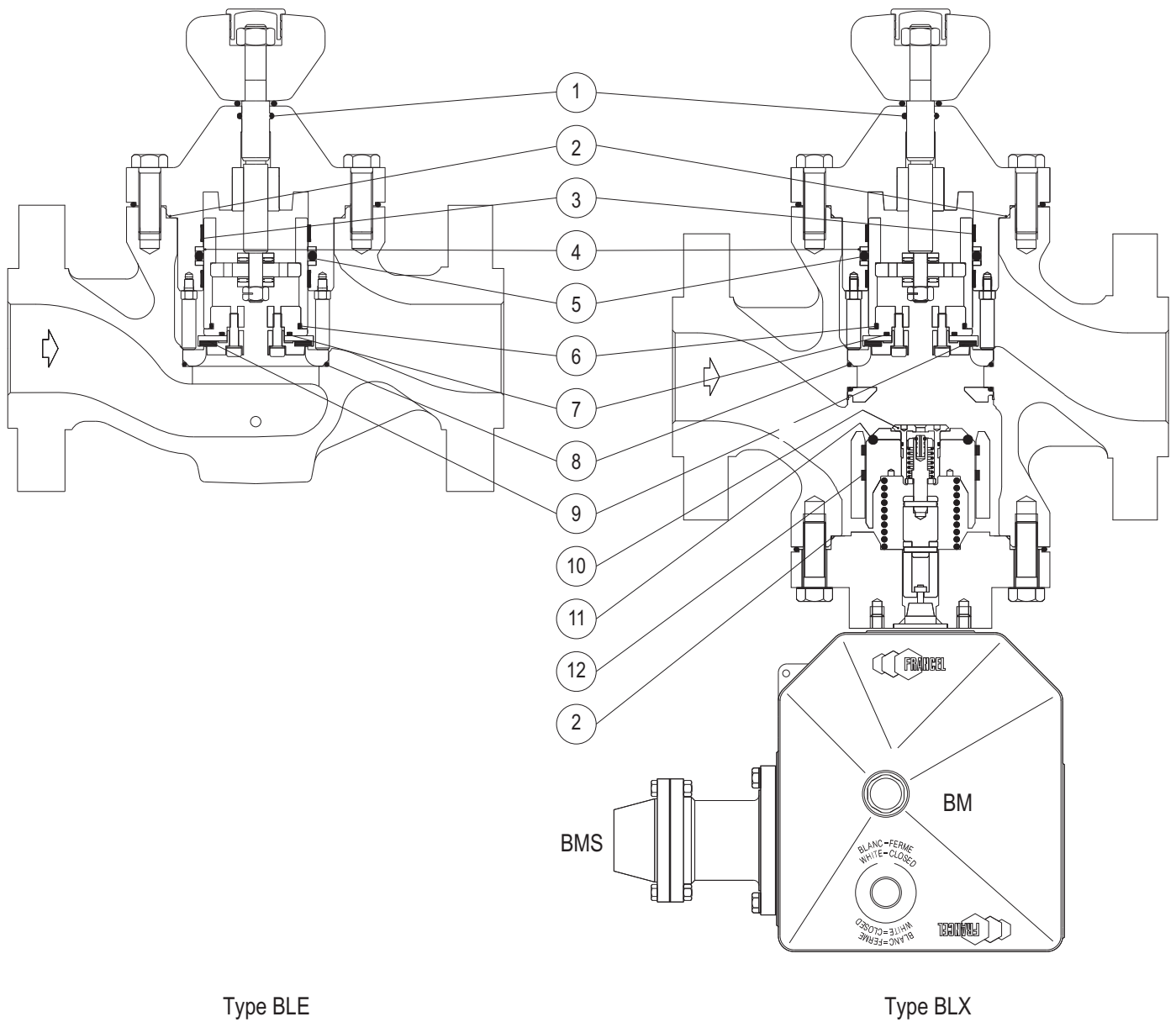

Figure 8. BLE-BLX Spare Parts

# BLE - BLX

---

## Industrial Regulators

### Emerson Process Management Regulator Technologies, Inc.

USA - Headquarters  
McKinney, Texas 75069-1872, USA  
Tel: +1 800 558 5853  
Outside U.S. +1 972 548 3574

Asia-Pacific  
Shanghai 201206, China  
Tel: +86 21 2892 9000

Europe  
Bologna 40013, Italy  
Tel: +39 051 419 0611

Middle East and Africa  
Dubai, United Arab Emirates  
Tel: +971 4811 8100

## Natural Gas Technologies

### Emerson Process Management Regulator Technologies, Inc.

USA - Headquarters  
McKinney, Texas 75069-1872, USA  
Tel: +1 800 558 5853  
Outside U.S. +1 972 548 3574

Asia-Pacific  
Singapore 128461, Singapore  
Tel: +65 6777 8337

Europe  
O.M.T. Tartarini s.r.l. Via P. Fabbri 1,  
I-40013 Castel Maggiore (Bologna), Italy  
Tel: +39 051 419 0611  
Francel SAS, 3 ave Victor Hugo,  
CS 80125 - Chartres 28008, France  
Tel: +33 2 37 33 47 00

Middle East and Africa  
Dubai, United Arab Emirates  
Tel: +971 4811 8100

## TESCOM

### Emerson Process Management Tescom Corporation

USA - Headquarters  
Elk River, Minnesota 55330-2445, USA  
Tels: +1 763 241 3238  
+1 800 447 1250

Asia-Pacific  
Shanghai 201206, China  
Tel: +86 21 2892 9499

Europe  
Selmsdorf 23923, Germany  
Tel: +49 38823 31 287

For further information visit [www.emersonprocess.com/regulators](http://www.emersonprocess.com/regulators)

The Emerson logo is a trademark and service mark of Emerson Electric Co. All other marks are the property of their prospective owners. Francel is a mark of Francel SAS, a business of Emerson Process Management.

*The contents of this publication are presented for informational purposes only, and while every effort has been made to ensure their accuracy, they are not to be construed as warranties or guarantees, express or implied, regarding the products or services described herein or their use or applicability. We reserve the right to modify or improve the designs or specifications of such products at any time without notice.*

Emerson Process Management does not assume responsibility for the selection, use or maintenance of any product. Responsibility for proper selection, use and maintenance of any Emerson Process Management product remains solely with the purchaser.

**O.M.T. Officina Meccanica Tartarini S.R.L.**, R.E.A 184221 BO Cod. Fisc. 00623720372 Part. IVA 00519501209 N° IVA CEE IT 00519501209,  
Cap. Soc. 1.548 000 Euro i.v. R.I. 00623720372 - M BO 020330

**Francel SAS**, SIRET 552 068 637 00057 APE 2651B, N° TVA : FR84552068637, RCS Chartres B 552 068 637, SAS capital 534 400 Euro