

Type FL Relief or Backpressure Regulator

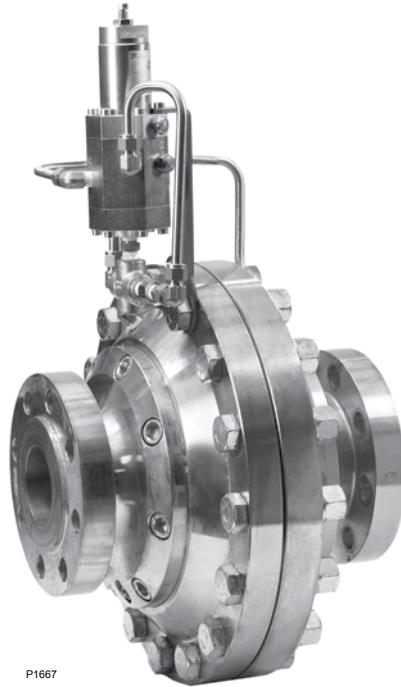

P1667

Figure 1. Type FL Relief Valve or Backpressure Regulator

Features

- **Control Accuracy**—Keeps constant inlet pressures to downstream equipment by accurately controlling system pressures at widely varying flow rates and supply pressures for maximum efficiency and best operation.
- **Versatility**—A wide variety of applications such as medium to high-pressure natural gas transmission and distribution systems, power plants, monitors and sour gas.
- **Tight Shutoff**—A combination of soft seat and metal plug with a knife edge provides a long lasting reliable shutoff.
- **Easy Startup**—Equal inlet and outlet pressure ratings allow easier startup and shutdown.
- **High Capacity**—Up to NPS 10 / DN 250 body size, the body design and flow passage allows exceptionally high capacities with a maximum C_g of 30,600 - 2:1 line size.
- **In-Service Travel Indicator**—The travel indicator with protective cover, responds to the precise movement of the diaphragm and plug assembly and shows the actual valve position.

Introduction

Type FL relief valve or backpressure regulator is accurate, pilot-operated and designed for high-pressure transmission/city gate, large capacity distribution systems and power plant feeds. Type FL provides smooth, tight shutoff and long service life. The relief valve or backpressure regulator utilizes a main valve actuator, a Type PRX/182 pressure reducing pilot.

The regulator's superior performance is due to the amplifying effect of the pilot and two-path control system. Changes in inlet pressure act quickly on the actuator diaphragm to provide fast response to system change.

Type PRX/182 Pilot Description

A Type PRX/182 pressure reducing pilot has the ability to handle a wide range of setpoints from 29 to 1160 psig / 2.00 to 80.0 bar.

Bulletin 71.4:FL

Specifications

The Specifications section gives some general specifications for the Type FL relief valve or backpressure regulator. The nameplates give detailed information for a particular regulator as it comes from the factory.

Available Configuration

Type FL: Pilot-operated relief or backpressure regulator for medium to high set pressures

Body Sizes

Type FL: NPS 1, 2, 3, 4, 6, 8 and 10 /
DN 25, 50, 80, 100, 150, 200 and 250

Main Valve End Connection Style and Pressure Ratings⁽¹⁾

CL300 RF: 740 psig / 51.0 bar⁽³⁾
CL600 RF: 1480 psig / 102 bar⁽³⁾

Maximum Inlet and Outlet (Casing) Pressure⁽¹⁾

1480 psig / 102 bar⁽³⁾

Set (Control) Pressure Ranges

See Table 1

Flow and Coefficients

See Table 3

Pilot Regulator Flow Coefficients

Type PRX Pilot: $C_g: 10.5; C_v: 0.36; C_1: 29$

Pilot Connections

1/4 NPT

Pressure Registration

External

Temperature Capabilities⁽¹⁾⁽²⁾

Nitrile (NBR) or Fluorocarbon (FKM) Disk:

-4 to 140°F / -20 to 60°C

Nitrile (NBR) Disk: -20 to 140°F / -29 to 60°C⁽⁴⁾

Approximate Weights (Including Pilot)

See Table 5

Construction Materials

Type FL Main Valve

Main Body and Flanges: Steel

Sleeve and Disk Holder: Steel

Diaphragm Plates: Steel

Diaphragm: Nitrile (NBR) with PVC coating

Disk O-rings: Nitrile (NBR) or Fluorocarbon (FKM)

Disk: Nitrile (NBR) or Fluorocarbon (FKM) rubber

Type PRX Pilot

Body: Steel

Trim: Stainless Steel

Diaphragm: Nitrile (NBR) or Fluorocarbon (FKM)

Disk O-rings: Nitrile (NBR) or Fluorocarbon (FKM)

Disk: Polyurethane (PU) or Fluorocarbon (FKM)

1. The pressure/temperature limits in this Bulletin and any applicable standard or code limitation should not be exceeded.

2. Type PRX Fluorocarbon (FKM) elastomer is limited to 0°F / -18°C.

3. At average ambient temperature.

4. Meets or exceeds ANSI/FCI 70-3 Class VI/VII leakage limits at maximum operating differential pressure.

Table 1. Relief Set Pressure Control

PILOT TYPE	RELIEF SET PRESSURE RANGE		PILOT CONTROL INFORMATION									
	psig	bar	Part Number	Color	Wire Diameter		Free Length		Maximum Operating Pressure		Maximum Emergency Pressure	
					In.	mm	In.	mm	psig	bar	psig	bar
PRX/182	29 to 116	2.0 to 8.0	M0255220X12	Black	0.157	4.00	2.16	55.0	609	42.0	1480	102
	73 to 290	5.0 to 20.0	M0255200X12	Gold	0.217	5.50	2.01	51.0				
	217 to 609	15.0 to 42	M0255190X12	Red	0.256	6.50	1.97	50.0				
PRX-AP/182	435 to 1160	30.0 to 80.0	M0273790X12	Clear	0.335	8.50	3.94	100	1160	80.0	1480	102

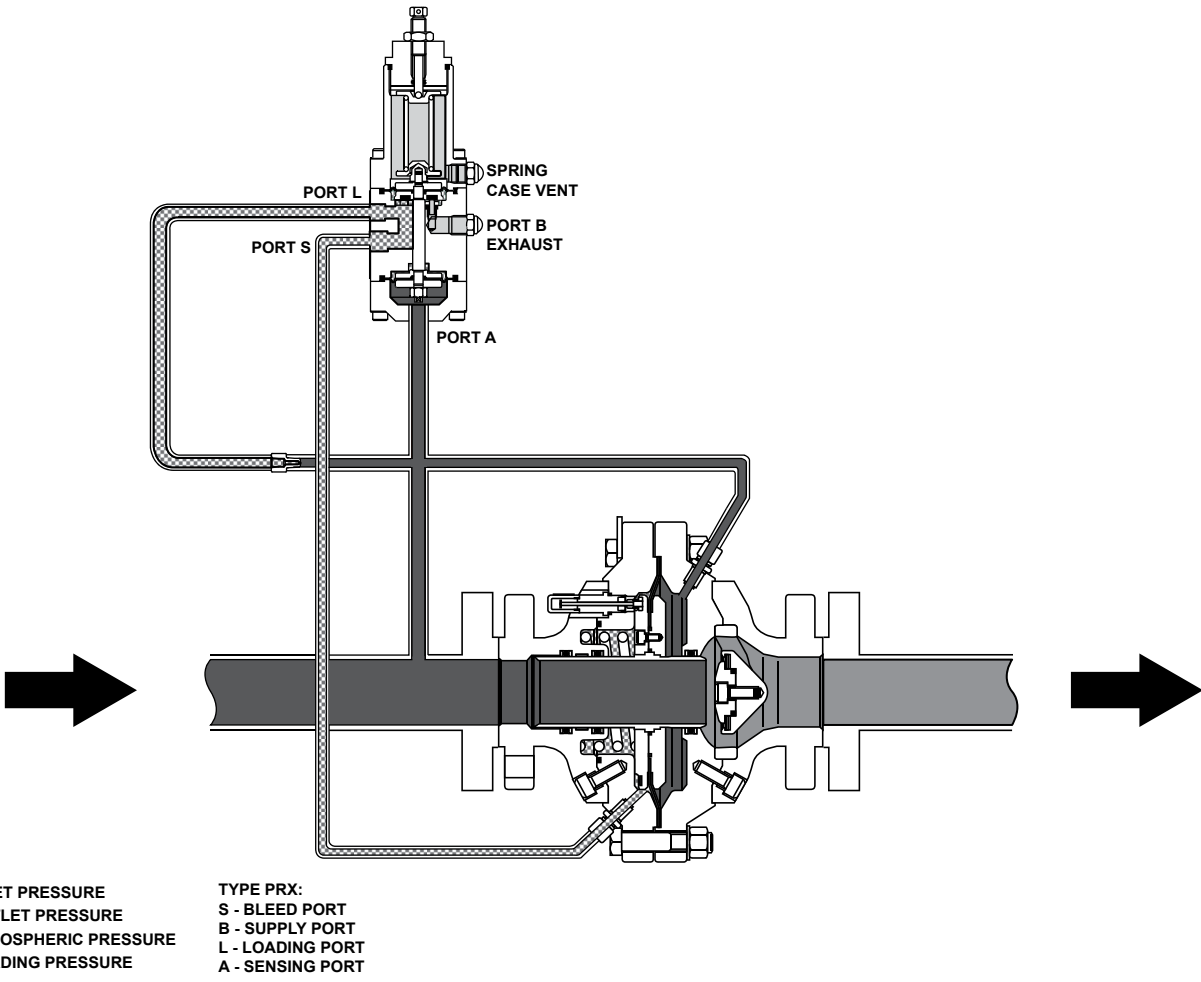

Figure 2. Type FL Relief Valve or Backpressure Regulator Operational Schematic

Table 2. Pilot Set Pressure Build-Up

PILOT TYPE	SET PRESSURE CONTROL RANGE, SPRING PART NUMBER AND COLOR	SET PRESSURE ⁽¹⁾		BUILD-UP OVER SET PRESSURE NEEDED TO BEGIN OPENING MAIN VALVE ⁽²⁾		BUILD-UP OVER SET PRESSURE NEEDED TO FULLY OPEN MAIN VALVE ⁽³⁾		PRESSURE DROP BELOW SET PRESSURE NEEDED TO RESEAT PILOT	
		psig	bar	psig	bar	psig	bar	psig	bar
PRX/182	29 to 116 psig / 2.0 to 8.0 bar M0255220X12 Black	30	2.1	1.2	0.08	2.8	0.19	1.0	0.69
		60	4.1	1.7	0.12	3.7	0.26	1.0	0.69
		80	5.5	1.9	0.13	4.0	0.28	1.0	0.69
		100	6.9	2.8	0.19	5.0	0.35	1.0	0.69
	73 to 290 psig / 5.0 to 20.0 bar M0255200X12 Gold	75	5.2	2.3	0.16	5.1	0.35	2.1	0.14
		100	6.9	2.5	0.17	5.9	0.41	2.1	0.14
		150	10.3	3.5	0.24	6.8	0.47	2.1	0.14
		200	13.8	4.0	0.28	8.0	0.55	2.1	0.14
	217 to 609 psig / 14.9 to 41.7 bar M0255190X12 Red	250	17.2	4.0	0.28	8.9	0.61	2.1	0.14
		225	15.5	4.0	0.28	10.2	0.70	2.7	0.19
300		20.7	4.0	0.28	10.5	0.72	2.7	0.19	
400		27.6	4.1	0.28	10.7	0.74	2.7	0.19	
PRX-AP/182	435 to 1160 psig / 30.0 to 80.0 bar M0273790X12 Clear	450	31.0	4.3	0.3	11.0	0.76	3.3	0.23
		500	34.5	4.5	0.31	11.1	0.77	3.3	0.23
		600	41.4	5.1	0.35	11.1	0.77	3.3	0.23
		1050	72.4	5.1	0.35	11.1	0.77	3.3	0.23

1. Set pressure is defined as the pressure at which the pilot starts-to-discharge.
 2. Crack point pressure of the main valve of the inlet pressure build-up over the set pressure at which the main valve starts audible flow.
 3. Inlet pressure build-up over the set pressure for the main valve to achieve wide-open flow capacity.

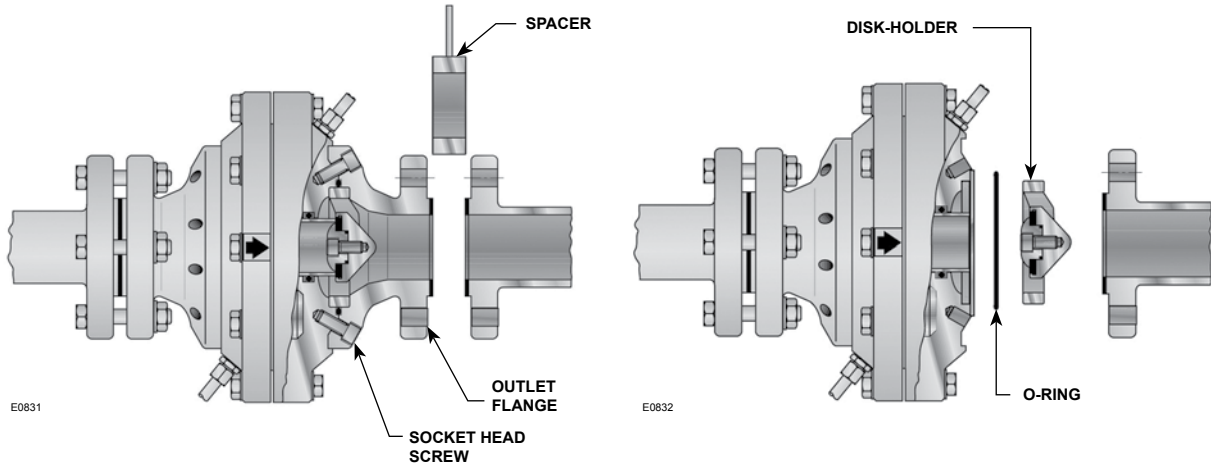

Figure 3. Outlet Flange Spacer Installation

Table 3. Flow and Sizing Coefficients

BODY SIZE, NPS / DN	LINE SIZE EQUALS BODY SIZE						2:1 LINE SIZE TO BODY SIZE RATIO					
	Regulating		C ₁	IEC Sizing Coefficient			Regulating		C ₁	IEC Sizing Coefficient		
	C _g	C _v		X _T	F _D	F _L	C _g	C _v		X _T	F _D	F _L
Type FL												
1 / 25	590	18.4	32.1	0.65	0.73	0.89	550	16.4	33.5	0.71	0.69	0.89
2 / 50	2300	70.6	32.6	0.67	0.69	0.89	2200	67.7	32.5	0.67	0.68	0.89
3 / 80	5200	161.9	32.1	0.69	0.70	0.89	4900	161.4	30.4	0.58	0.70	0.89
4 / 100	8000	249.3	32.1	0.65	0.65	0.89	7900	244.9	32.3	0.66	0.64	0.89
6 / 150	20,300	735.8	27.6	0.48	0.71	0.89	18,400	666.7	27.6	0.48	0.67	0.89
8 / 200	30,900	1080.4	28.6	0.52	0.66	0.89	30,600	1069.9	28.6	0.52	0.65	0.89
10 / 250	52,100	1615.4	32.3	0.66	0.69	0.89	51,500	1599.7	32.2	0.66	0.69	0.89

Principle of Operation

A pressure relief valve is a throttling pressure control device that opens and closes to ensure the downstream pressure does not rise above a predetermined pressure. Tartatini™ relief valves cannot be used as ASME safety relief valves. A backpressure regulator is a device that controls and responds to changes in the upstream pressure. It functions the same as a relief valve in that it opens on increasing upstream pressure.

Relief Valve

As long as the inlet pressure is below the set pressure, the pilot control spring keeps the pilot valve plug closed. Inlet pressure passes through the restrictor and registers as loading pressure on the main valve diaphragm chamber. Force from the main spring, in addition to pilot loading pressure, provide loading pressure to keep the main valve diaphragm and plug assembly tightly shut off.

When the inlet pressure rises above the set pressure, the pressure on the pilot diaphragm overcomes the pilot control spring and opens the pilot valve plug. The pilot then exhausts the loading pressure from the main valve diaphragm chamber. The pilot continuously exhausts gas when the inlet pressure is above the set pressure. The inlet pressure unbalance overcomes the main spring force and opens the diaphragm and plug assembly.

As the inlet pressure drops below the set pressure, the pilot control spring closes the pilot valve plug and the exhaust to atmosphere stops. Force from the main spring, along with pilot loading pressure, pushes the diaphragm and plug assembly onto the knife-edged seat, producing tight shutoff.

Backpressure Regulator

As long as inlet pressure remains below setpoint, the pilot control spring keeps the pilot valve plug closed. Inlet pressure passes through the upper port around the upper portion of the valve plug and then through the hollow passage in that valve plug. Force from the main spring, in addition to pilot loading pressure, provide downward loading pressure to keep the main valve diaphragm and plug assembly tightly shut off.

When inlet pressure rises above the set pressure, pressure on the pilot diaphragm overcomes the control spring to close the upper port and stroke the valve plug to open the lower port. The pilot exhausts loading pressure from the main valve diaphragm chamber. Inlet pressure unbalance overcomes the main spring force to open the diaphragm and plug assembly.

While the main valve is throttling, the upper port of the pilot stays closed. The pilot exhausts only when it repositions the main valve. As inlet pressure drops below setpoint, the pilot control spring overcomes the diaphragm force to stroke the valve plug down to close the lower port and open the upper port. Force from the main spring, along with pilot loading pressure, pushes the diaphragm and plug assembly onto the knife-edged seat, producing tight shutoff.

Table 4. Relief Capacities

SET PRESSURE RANGE, PILOT SPRING PART NUMBER AND COLOR	SET PRESSURE		CAPACITIES IN THOUSANDS OF SCFH / NM ³ /H OF 0.6 SPECIFIC GRAVITY NATURAL GAS													
			NPS 1 / DN 25		NPS 2 / DN 50		NPS 3 / DN 80		NPS 4 / DN 100		NPS 6 / DN 150		NPS 8 / DN 200		NPS 10 / DN 250	
	psig	bar	SCFH	Nm ³ /h	SCFH	Nm ³ /h	SCFH	Nm ³ /h	SCFH	Nm ³ /h	SCFH	Nm ³ /h	SCFH	Nm ³ /h	SCFH	Nm ³ /h
29 to 116 psig / 2.0 to 8.0 bar M0255220X12 Black	30	2.1	37	1.0	147	3.9	331	8.9	503	13.5	1282	34.4	2011	53.9	3285	88.0
	60	4.1	62	1.7	243	6.5	547	14.7	830	22.2	2115	56.7	3320	89.0	5425	145
	80	5.5	78	2.1	306	8.2	688	18.4	1045	28.0	2663	71.4	4179	112	6830	183
	100	6.9	94	2.5	371	9.9	834	22.4	1267	34.0	3230	86.6	5069	136	8283	222
73 to 290 psig / 5.0 to 20.0 bar M0255200X12 Gold	75	5.2	75	2.0	294	7.9	661	17.7	1004	26.9	2558	68.6	4014	108	6560	176
	100	6.9	95	2.5	374	10.0	841	22.5	1277	34.2	3254	87.2	5107	137	8345	224
	150	10.3	135	3.6	531	14.2	1196	32.1	1816	48.7	4627	124	7262	195	11,867	318
	200	13.8	175	4.7	690	18.5	1553	41.6	2358	63.2	6009	161	9430	253	15,410	413
217 to 609 psig / 14.9 to 41.7 bar M0255190X12 Red	225	15.5	197	5.3	774	20.7	1742	46.7	2645	70.9	7382	198	11,585	310	18,932	507
	300	20.7	256	6.9	1008	27.0	2267	60.8	3443	92.3	8774	235	13,770	369	22,503	603
	400	27.6	335	9.0	1318	35.3	2966	79.5	4503	121	11,478	308	18,013	483	29,437	789
	450	31	375	10.1	1474	39.5	3316	88.9	5036	135	12,835	344	20,143	540	32,917	882
435 to 1160 psig / 30.0 to 80.0 bar M0273790X12 Clear	450	31	375	10.1	1474	39.5	3316	88.9	5036	135	12,835	344	20,143	540	32,917	882
	500	34.5	414	11.1	1629	43.7	3666	98.2	5566	149	14,187	380	22,265	597	36,384	975
	600	41.4	493	13.2	1939	52.0	4363	117	6625	178	16,885	453	26,499	710	43,304	1161
	1050	72.4	847	22.7	3333	89.3	7500	201	11,389	305	29,027	778	45,554	1221	74,442	1995

Installation

Type FL relief valve or backpressure regulator is installed in a horizontal or vertical pipeline as long as flow through the body matches the flow arrow on the main valve. An optional outlet flange spacer (Figure 3) is available to be installed downstream of the regulator. Once the spacer and outlet flange are removed, the disk holder and trim parts are easily accessed. Dimensions are given in Figure 4.

Type FL may be installed in any position, but is normally installed in a horizontal pipeline with the pilot or pilots above the body. The optimal location for the sense is between the Type FL and the upstream block valve. If the sense cannot be located between the Type FL and upstream block valve, contact your local Sales Office for Startup assistance.

Capacity Information

Note

Type FL flow capacities are laboratory verified; therefore, they may be sized for 100% flow using published capacities as shown. It is not necessary to reduce published capacities.

Table 4 shows the natural gas regulating capacities of the Type FL relief valve or backpressure regulator at selected inlet pressures and set pressure settings. Flows are in thousands of SCFH at 60°F and 14.7 psia (and in thousands of Nm³/h at 0°C and 1.01325 bar) of 0.6 specific gravity natural gas.

To find approximate relief capacities at set pressures or build-ups not given in Table 2 or 4, use one of the following formulas. Then, if necessary, convert using the factors provided below.

For critical pressure drops (absolute outlet pressure equal to or less than one-half of absolute inlet pressure), use the following formula:

$$Q = (P_1)(C_g)(1.29)$$

For pressure drops lower than critical (absolute outlet pressure greater than one-half of absolute inlet pressure).

$$Q = \sqrt{\frac{520}{GT}} C_g P_1 \sin \left(\frac{3417}{C_1} \sqrt{\frac{\Delta P}{P_1}} \right) \text{DEG}$$

where,

- Q = gas flow rate, SCFH
- P₁ = absolute inlet pressure, psia (P₁ gauge + 14.7)
- C_g = regulating or wide-open gas sizing coefficient from the Specifications section and Table 3
- G = gas specific gravity of the gas
- T = absolute temperature of gas at inlet, °Rankine
- C₁ = flow coefficient
- ΔP = pressure drop across the regulator, psi

To determine equivalent capacities for air, propane, butane or nitrogen, multiply the capacity by the following appropriate conversion factor: 0.775 for air, 0.625 for propane, 0.547 for butane or 0.789 for nitrogen. For gases of other specific gravities, multiply the given capacity by 0.775 and divide by the square root of the appropriate specific gravity.

Then, if capacity is desired in normal cubic meters per hour at 0°C and 1.01325 bar, multiply SCFH by 0.0268.

Bulletin 71.4:FL

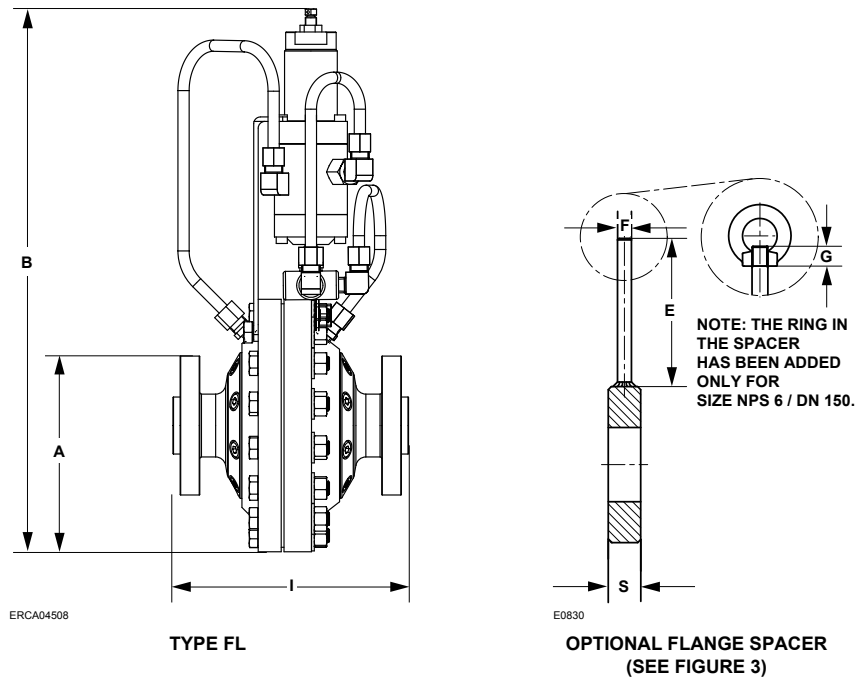

Figure 4. Dimensions

Table 5. Dimensions

BODY SIZE NPS / DN	DIMENSION, IN. / mm							APPROXIMATE WEIGHT, LBS / kg	
	(Face-to-Face / I) CL300 to CL600	A	B	E	F	G	S		
1 / 25	8.3 / 211	8.9 / 225	17.1 / 430	4.7 / 120	0.39 / 10	----	1.18 / 30	68 / 31	
2 / 50	11.3 / 286	11.3 / 287	19.5 / 490	4.7 / 120	0.39 / 10	----	1.97 / 50	132 / 60	
3 / 80	13.3 / 337	15.7 / 400	23.4 / 590	4.7 / 120	0.39 / 10	----	2.36 / 60	326 / 148	
4 / 100	15.5 / 394	18.9 / 480	26.8 / 680	4.7 / 120	0.39 / 10	----	2.36 / 60	443 / 201	
6 / 150	20.0 / 508	24.0 / 610	33.9 / 860	4.7 / 120	0.39 / 10	0.47 / 12	3.15 / 80	1058 / 480	
8 / 200	CL300	CL600	25.7 / 653	39.5 / 1000	4.7 / 120	0.39 / 10	0.47 / 12	3.93 / 100	1367 / 620
	22.4 / 569	24.0 / 610							
10 / 250	CL300	CL600	30.9 / 785	43.3 / 1100	4.7 / 120	0.39 / 10	0.47 / 12	3.93 / 100	2623 / 1190
	27.8 / 708	29.6 / 752							

Ordering Information

Carefully review each specification in the Specifications section, then complete the Specification Worksheet on page 8.

If a pilot setpoint is not requested, the regulator will be set at the approximate midrange.

Ordering Guide

Body Size (Select One)

Type FL

(Same Inlet and Outlet Size)

- NPS 1 / DN 25**
- NPS 2 / DN 50**
- NPS 3 / DN 80**
- NPS 4 / DN 100**
- NPS 6 / DN 150**
- NPS 8 / DN 200**
- NPS 10 / DN 250**

End Connection Style (Select One)

- CL300 RF**
- CL600 RF**

O-ring Material (Select One)

- Nitrile (NBR)**
- Fluorocarbon (FKM)**

Disk Material (Select One)

- Nitrile (NBR) **(standard)*****
- Fluorocarbon (FKM)**

Pilot Type (Select One)

- PRX/182
- PRX-AP/182

Outlet Flange Spacer (Optional)

- Yes**
- No

Set Pressure Range (Select One)

Type PRX/182

- 29 to 116 psig / 2.00 to 8.00 bar, Black**
- 73 to 290 psig / 5.00 to 20.0 bar, Gold***
- 217 to 609 psig / 15.0 to 42.0 bar, Red**

Type PRX-AP/182

- 435 to 1160 / 30.0 to 80.0 bar, Clear**

Main Valve Mounting Position (Select One)

- Horizontal
- Vertical

Pilot Diaphragm (Select One)

- Nitrile (NBR) **(standard)*****
- Fluorocarbon (FKM)**

Pilot Disk (Select One)

- Polyurethane (PU) **(standard)****
- Fluorocarbon (FKM)**

Main Valve Replacement Parts Kit (Optional)

- Yes, send one replacement parts kit to match this order.

Main Valve Replacement Commission Kit (Optional)

- Yes, send one commission kit to match this order.

Pilot Valve Replacement Parts Kit (Optional)

- Yes, send one replacement parts kit to match this order.

Bulletin 71.4:FL

Ordering Guide (continued)

Regulators Quick Order Guide	
***	Readily Available for Shipment
**	Allow Additional Time for Shipment
*	Special Order, Constructed from Non-Stocked Parts. Consult your local Sales Office for Availability.
Availability of the product being ordered is determined by the component with the longest shipping time for the requested construction.	

Specification Worksheet	
Application:	
Specific Use	_____
Line Size	_____
Fluid Type	_____
Specific Gravity	_____
Temperature	_____
Does the Application Require Overpressure Protection?	
<input type="checkbox"/> Yes	<input type="checkbox"/> No
Pressure:	
Maximum Inlet Pressure	_____
Minimum Inlet Pressure	_____
Differential Pressure	_____
Set Pressure	_____
Maximum Flow	_____
Accuracy Requirements:	
Less Than or Equal To:	
<input type="checkbox"/> 5%	<input type="checkbox"/> 10% <input type="checkbox"/> 20% <input type="checkbox"/> 40%
Construction Material Requirements (if known):	

Industrial Regulators

Emerson Process Management Regulator Technologies, Inc.

USA - Headquarters
McKinney, Texas 75070 USA
Tel: +1 800 558 5853
Outside U.S. +1 972 548 3574

Asia-Pacific
Shanghai 201206, China
Tel: +86 21 2892 9000

Europe
Bologna 40013, Italy
Tel: +39 051 419 0611

Middle East and Africa
Dubai, United Arab Emirates
Tel: +971 4811 8100

Natural Gas Technologies

Emerson Process Management Regulator Technologies, Inc.

USA - Headquarters
McKinney, Texas 75070 USA
Tel: +1 800 558 5853
Outside U.S. +1 972 548 3574

Asia-Pacific
Singapore 128461, Singapore
Tel: +65 6770 8337

Europe
Bologna 40013, Italy
Tel: +39 051 419 0611
Chartres 28008, France
Tel: +33 2 37 33 47 00

Middle East and Africa
Dubai, United Arab Emirates
Tel: +971 4811 8100

TESCOM

Emerson Process Management Tescom Corporation

USA - Headquarters
Elk River, Minnesota 55330-2445, USA
Tels: +1 763 241 3238
+1 800 447 1250

Europe
Selmsdorf 23923, Germany
Tel: +49 38823 31 287

Asia-Pacific
Shanghai 201206, China
Tel: +86 21 2892 9499

For further information visit www.emersonprocess.com/regulators

The Emerson logo is a trademark and service mark of Emerson Electric Co. All other marks are the property of their prospective owners. Fisher is a mark owned by Fisher Controls International LLC, a business of Emerson Process Management.

The contents of this publication are presented for informational purposes only, and while every effort has been made to ensure their accuracy, they are not to be construed as warranties or guarantees, express or implied, regarding the products or services described herein or their use or applicability. We reserve the right to modify or improve the designs or specifications of such products at any time without notice.

Emerson Process Management Regulator Technologies, Inc. does not assume responsibility for the selection, use or maintenance of any product. Responsibility for proper selection, use and maintenance of any Emerson Process Management Regulator Technologies, Inc. product remains solely with the purchaser.