

DVC6200 or DVC2000 Digital Valve Controller on 1051 Size 33 and 1052 Size 20 and 33 Actuator • (Window Mount)

Use these instructions to mount a Fisher® FIELDVUE™ DVC6200 or DVC2000 digital valve controller on Fisher 1051 Size 33 and 1052 Size 20 and 33 actuators.

WARNING

Avoid personal injury or property damage from sudden release of process pressure or bursting of parts. Before performing any installation operations:

- **Always wear protective clothing, gloves, and eyewear.**
- **Do not remove the actuator from the valve while the valve is still pressurized.**
- **Disconnect any operating lines providing air pressure, electric power, or a control signal to the actuator. Be sure the actuator cannot suddenly open or close the control valve.**
- **Use bypass valves or completely shut off the process to isolate the control valve from process pressure. Relieve process pressure from both sides of the control valve.**
- **Vent the pneumatic actuator loading pressure and relieve any actuator spring precompression.**
- **Use lock-out procedures to be sure that the above measures stay in effect while you work on the equipment.**
- **Check with your process or safety engineer for any additional measures that must be taken to protect against process media.**

Refer to figure 2 and the parts list for mounting parts identification. Refer to the DVC6200 or DVC2000 digital valve controller instruction manual for digital valve controller parts identification. Refer to the appropriate actuator instruction manual for actuator installation, operation, maintenance, and parts identification. Figure 1 shows the arced feedback assembly.

1. Isolate the control valve from the process line pressure and release pressure from both sides of the valve body. Shut off all pressure lines to the actuator, releasing all pressure from actuator. Use lock-out procedures to be sure that the above measures stay in effect while you work on the equipment.

2. Remove the cover plate screws and cover plate from the actuator, if present.

3. Install the cam (key 1) onto the lever of actuator using hex head mach screws (key 2). It will be necessary for use of arced feedback mechanism. Consult the appropriate actuator instruction manual for proper actuator disassembly and reassembly. Ensure that the cam is oriented as shown in figure 2.

4. Attach the mounting adaptor (key 3) to the yoke using the four hex socket cap screws (key 4).

5. Attach the digital valve controller to the arced feedback assembly (key 5) and tighten the hex socket cap screws (key 6).

6. Install the arced feedback assembly (key 5), along with the digital valve controller, to the mounting adaptor (key 3) using hex socket cap screws (key 7) as shown in figure 2. Ensure that the roller of arced feedback assembly is centered and resting on the cam surface.

7. Make pneumatic and electrical connections to the digital valve controller as described in the digital valve controller instruction manual.

8. It may be necessary to fine tune the placement of the cam so that the digital valve controllers receives the proper feedback.

9. Setup and calibrate the digital valve controller as described in the instruction manual or quick start guide.

For additional information concerning mounting, setup, calibration, and maintenance of the DVC6200 or DVC2000 digital valve controller, refer to the appropriate instruction manual.

Note

Neither Emerson, Emerson Process Management, nor any of their affiliated entities assumes responsibility for the selection, use or maintenance of any product. Responsibility for the selection, use, and maintenance of any product remains with the purchaser and end user.



DVC6200 or DVC2000 Digital Valve Controller on 1051 Size 33 and 1052 Size 20 and 33 Actuators (Window Mount)

Mounting Instructions
 D103447X012
 May 2010

PART LIST		
KEY	QTY	DESCRIPTION
1	1	CAM
2	2	10-24UNCX0.38" HEX HD SCREWS
3	1	ADAPTOR, MTG
4	4	5/16"-18UNCX0.62" SOCKET SCREWS
5	1	ARCED FEEDBACK ASSEMBLY
6	4	M8X1.25X16 SOCKET SCREWS
7	4	5/16"-18UNCX0.62" SOCKET SCREWS

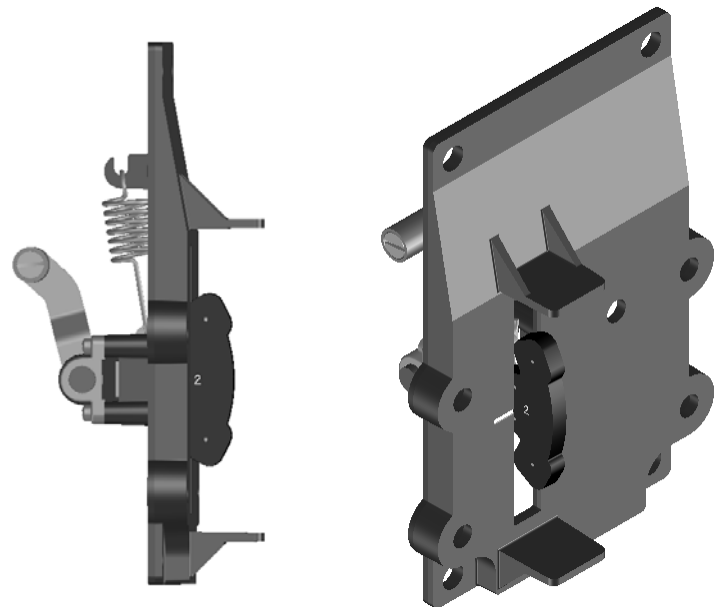
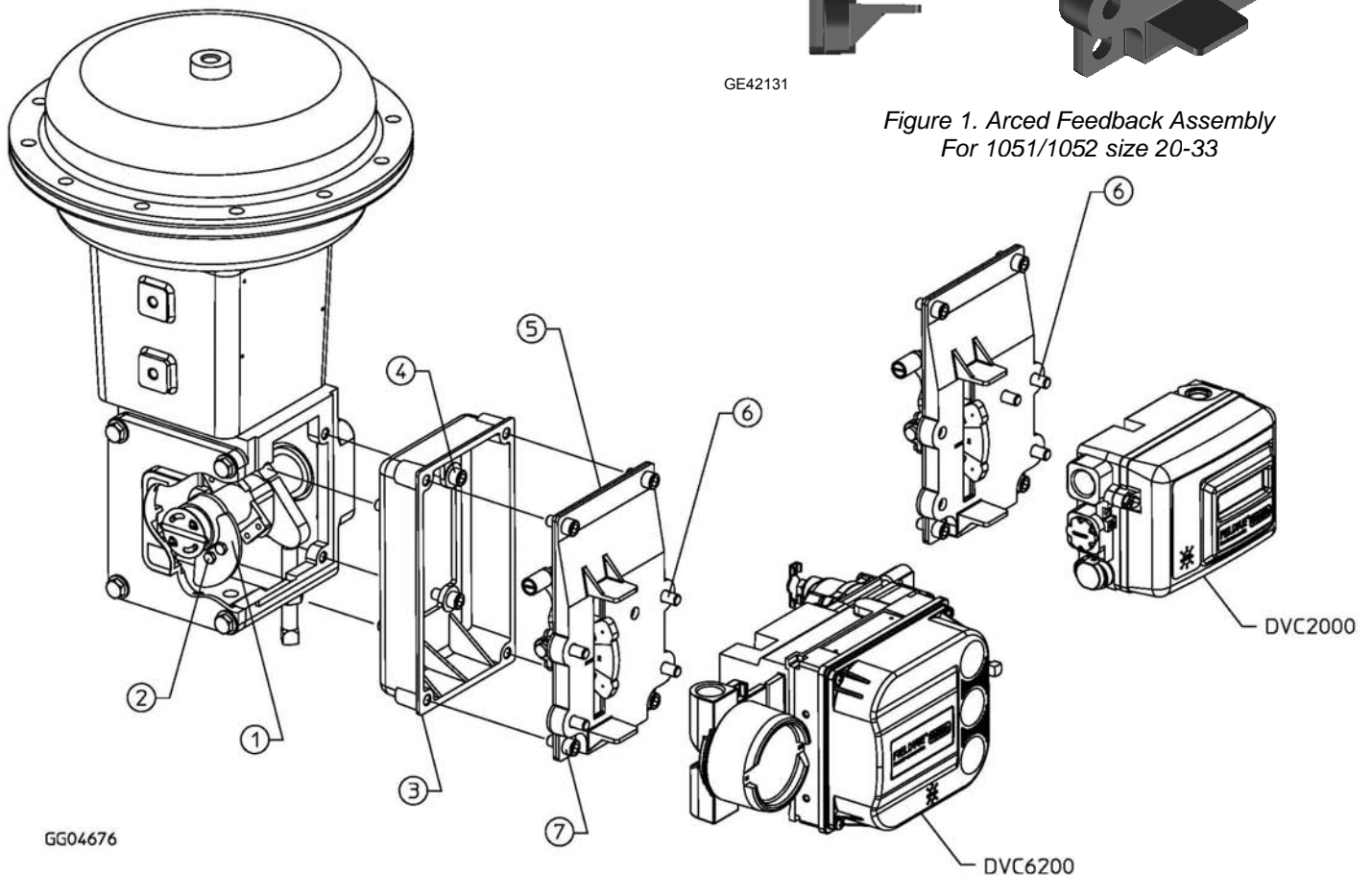

Figure 1. Arced Feedback Assembly For 1051/1052 size 20-33



NOTE:

DVC6200 uses 4 M8 socket screws (key 6) for mounting onto arced feedback assembly.
 DVC2000 uses 3 M8 socket screws (key 6) for mounting onto arced feedback assembly.

Figure 2. Mounting Parts Identification

Mounting Instructions
D103447X012
May 2010

DVC6200 or DVC2000 Digital Valve Controller on 1051 Size 33 and 1052 Size 20 and 33 Actuator• (Window Mount)

Fisher and FIELDVUE are marks owned by one of the companies in the Emerson Process Management business division of Emerson Electric Co. Emerson Process Management, Emerson, and the Emerson logo are trademarks and service marks of Emerson Electric Co. All other marks are the property of their respective owners.

The contents of this publication are presented for informational purposes only, and while every effort has been made to ensure their accuracy, they are not to be construed as warranties or guarantees, express or implied, regarding the products or services described herein or their use or applicability. All sales are governed by our terms and conditions, which are available upon request. We reserve the right to modify or improve the designs or specifications of such products at any time without notice. Neither Emerson, Emerson Process Management, nor any of their affiliated entities assumes responsibility for the selection, use, and maintenance of any product. Responsibility for the selection, use, and maintenance of any product remains solely with the purchaser and end user.

Emerson Process Management
Marshalltown, Iowa 50158 USA
Sorocaba, 18087 Brazil
Chatham, Kent ME4 4QZ UK
Dubai, United Arab Emirates
Singapore 128461 Singapore

www.Fisher.com