

March 2009

N100, N100A, N110, and N120 Series Differential Bypass and Backpressure Valves

WARNING

Failure to follow these instructions or to properly install and maintain this equipment could result in an explosion, and/or fire causing property damage and personal injury or death.

Fisher® equipment must be installed, operated, and maintained in accordance with federal, state, and local codes and manufacturer's instructions. The installation in most states must also comply with NFPA. 58 or ANSI standard K61.1.

Only personnel trained in the proper procedures, codes, standards, and regulations of the LP-Gas or Anhydrous Ammonia industries should install and service this equipment.

Introduction

Scope of the Manual

This manual covers instructions for the N100, N100A, N110, and N120 Series Differential Bypass and Backpressure Valves, shown in Figure 1.

Description

These valves are designed for use with propane, butane, and anhydrous ammonia at ambient temperatures. The valves can be used on other compressed gases, but the user should check with the factory to make sure the valve is suitable for the particular service.

A 1/4 NPT tapped and plugged boss on the inlet side of the body can be used to install a hydrostatic relief valve or a pressure gauge.

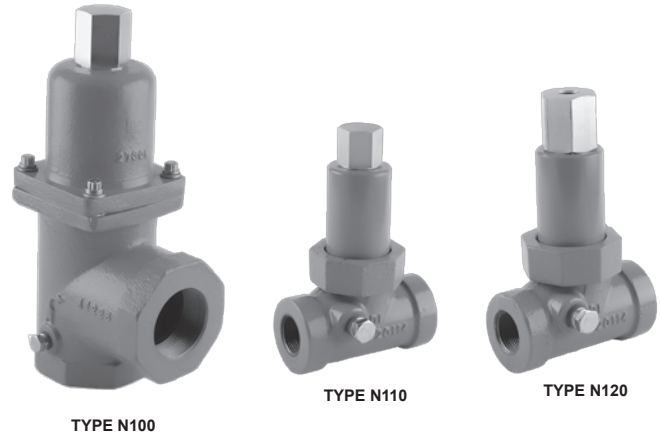

Figure 1. Bypass and Backpressure Valves

The Types N100, N100A, and N110 have internal sensing orifices so that no external sensing line is required.

N100 and N100A Series Bypass Valves

These valves are designed for bypass applications on NPS 2 through 4 (DN 50 through 100) size pumps. The throttling action of the valves allows only surplus pump discharge to be returned to the tank.

N110 Series Bypass Valve

These valves are designed for bypass applications on smaller pumps (5 to 40 GPM (18.9 to 151 l/min) propane) used on stationary tanks or delivery trucks.

N120 Series Backpressure Valve

These valves are intended for use with smaller pumps on cylinder filling applications. When installed after the liquid meter, the Type N120 holds a differential backpressure on the meter to prevent vapor from forming within the meter. An external sensing line is required.



N100, N100A, N110, and N120 Series

Specifications

Type Numbers, Differential Pressure Settings and Ranges See Tables 1, 2, and 3	Maximum Working Pressure 400 psig (27,6 bar) Temperature Capabilities -20° to 140°F (-29° to 60°C)
--	---

Table 1. Bypass Valves (For Large Pumps)

PUMP SIZE	TYPE NUMBER	BODY SIZE, NPS	DIFFERENTIAL PRESSURE SETTING, PSID (bar d)	DIFFERENTIAL PRESSURE RANGE, PSID (bar d)
NPS 2	N100A-08-1	1 FNPT	50 (3,4)	25 to 75 (1,7 to 5,2)
	N100A-08-2		115 (7,9)	50 to 150 (3,4 to 10,3)
NPS 2 to 3	N100A-10-1	1-1/4 FNPT	50 (3,4)	25 to 75 (1,7 to 5,2)
	N100A-10-2		115 (7,9)	50 to 150 (3,4 to 10,3)
	N100A-12-1	1-1/2 FNPT	50 (3,4)	25 to 75 (1,7 to 5,2)
	N100A-12-2		115 (7,9)	50 to 150 (3,4 to 10,3)
NPS 4	N100-16-1	2 FNPT	50 (3,4)	25 to 75 (1,7 to 5,2)
	N100-16-2	2 FNPT	115 (7,9)	50 to 150 (3,4 to 10,3)
	N100-20-2	2-1/2 FNPT	50 (3,4)	25 to 75 (1,7 to 5,2)

Table 2. Bypass Valves (For Small Pumps)

PUMPING CAPACITY, GPM (l/min)	TYPE NUMBER	BODY SIZE, NPS	DIFFERENTIAL PRESSURE SETTING, PSID (bar d)	DIFFERENTIAL PRESSURE RANGE, PSID (bar d)
5 to 20 (18,9 to 75,7)	N110-06-1	3/4 FNPT	50 (3,4)	25 to 75 (1,7 to 5,2)
	N110-06-2		100 (6,9)	75 to 150 (5,2 to 10,3)
20 to 40 (75,7 to 151)	N110-08-1	1 FNPT	50 (3,4)	25 to 75 (1,7 to 5,2)
	N110-08-2		100 (6,9)	75 to 150 (5,2 to 10,3)

Table 3. Backpressure Valves

LIQUID METER SIZE	TYPE NUMBER	BODY SIZE, NPS	DIFFERENTIAL PRESSURE SETTING, PSID (bar d)	DIFFERENTIAL PRESSURE RANGE, PSID (bar d)
NPS 3/4 or 1	N120-06-3	3/4 FNPT	12 (0,83)	10 to 20 (0,69 to 1,4)
	N120-08-3	1 FNPT		

Installation



Make sure the flow is in the same direction as the arrow cast into the valve body.

Refer to Figures 2 and 3.

Piping to the valve should be kept as short as possible with a minimum number of pipe fittings. Remove any pipe scale or foreign material from the piping before installing the valves.

The valves can be installed in any position. Make certain that flow is in the same direction as the arrow cast on the body.

Use an appropriate pipe compound on the male pipeline threads. Pull the valve onto the pipe until hand tight and then wrench tighten it for approximately two additional turns. Larger size valves may require an additional amount of torque to obtain a leak free connection.

After installation, pressurize the piping and use a leak detect solution on all joints to check for leakage. If leakage is found retighten fittings until leaking stops.

N100, N100A, N110, and N120 Series

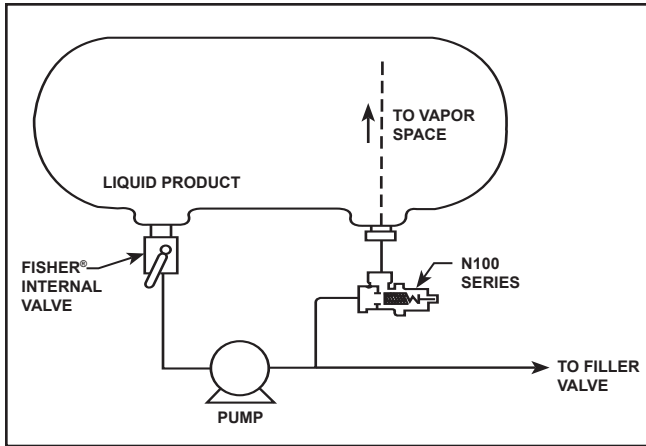

Figure 2. Types N100 and N100A Series Installation Schematic

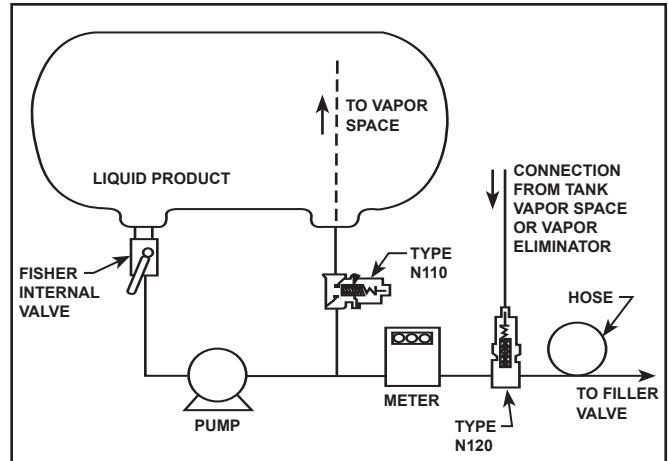

Figure 3. Types N110 and N120 Installation Schematic

Types N100, N100A, and N110 Valves

The Types N100 and N100A (see Figure 2) and Type N110 (see Figure 3) valve outlet piping should be connected to the tank vapor space. An external sensing line is not required for these valves.

Type N120 Valve

The Type N120 (see Figure 3) valve outlet piping should be connected to the tank piping leading to the hose reel. A 1/4-inch FNPT connection in the closing cap connects the external sensing line to the tank vapor space or vapor eliminator.

Principle of Operation

Types N100, N100A, and N110 Bypass Valves

Tank pressure registers through an orifice onto the spring case side of the inner valve (Type N100 or N100A) or diaphragm (Type N110). When pump pressure exceeds the tank pressure by the differential setpoint of the bypass valve, the inner valve lifts off the seat allowing flow through the valve back into the tank.

Type N120 Backpressure Valve

Pressure from the tank or vapor eliminator loads the spring case through the external sensing line. When pressure downstream of the meter registering on the body side of the diaphragm exceeds the differential setpoint the inner valve lifts allowing flow to pass through the valve.

Maintenance



CAUTION

Due to normal wear or damage that may occur from external sources, Fisher® equipment must be inspected and maintained periodically. The frequency of inspection and replacement of equipment depends upon the severity of the service conditions or the requirements of local, state, federal regulations, and manufacturer's instructions.

Do not use these valves if they leak, fail to work properly, have missing parts or have been damaged. A properly trained serviceman should make prompt repairs or replace the valve. Continued use without repair can create a hazardous or injurious situation.

Only use Regulator Technologies replacement parts.

Periodically inspect and verify the differential setpoint of the valves.

Adjustment

Each unit is factory set for the standard differential pressure or which was specified on the order. Settings can be adjusted with the ranges specified in Table 1, 2, or 3. Remove the closing cap and turn the adjusting

N100, N100A, N110, and N120 Series

screw clockwise (into the spring case) to increase the differential setting or counterclockwise (out of the spring case) to decrease the setting.

Use a pressure gauge on the outlet of the valve to monitor the change in the differential pressure setting.

Disassembly and Repair



WARNING

Release inlet and outlet pressure before starting repair or disassembly. Failure to do so could result in personal injury.

Note

Numbers in parenthesis () refer to the key number in the parts list.

Types N100 and N100A Disassembly

Refer to Figure 4:

1. Remove the 4 screws (key 13) and lock washers (key 19) and remove the spring case (key 2) from the body (key 1).
2. Replace the O-rings (keys 11 and 15) and the capseal (key 16). Coat the new parts with Dow Corning silicone grease or the equivalent reinstalling.
3. O-ring (key 15) fit around the outer diameter of the capseal (key 16). Do not bend the capseal (key 16) excessively during reassembly in the body (key 1).
4. Replace the inner valve (key 8) and washer (key 14) if needed. Grease the outside of the inner valve (key 8) and gently insert it into and through the capseal (key 16) as far as it will go. A slight twisting motion of the inner valve (key 8) may help in reassembly.



CAUTION

Proper valve operation requires that the registration hole in the inner valve (key 8) must face towards the outlet and not be filled with grease.

5. O-ring (key 12) can be replaced by removing the spring adjustment assembly (key 4) from the spring case (key 2).
6. After reassembly, pressure test for leakage and readjust the setpoint.

Type N110 Disassembly

Refer to Figure 5:

1. Unscrew the union nut (key 11) and remove the spring case (key 7) from the body (key 1).
2. To replace the diaphragm (key 4), remove the diaphragm assembly that includes the valve plug (key 3).
3. Unscrew the nut (key 6) and remove the diaphragm head (key 5). Replace the diaphragm (key 4) and reassemble.
4. O-ring (key 10) can be replaced by removing the spring adjustment assembly (key 9) from the spring case (key 7). Coat the new part with Dow Corning silicone grease or the equivalent before reinstalling.
5. Check the valve plug seat (key 3). Replace if it is badly scarred or damaged. **Make sure that the 2 registration passages are open.**



CAUTION

Proper valve operation requires that the registration hole in the inner valve must face towards the outlet and not be filled with grease.

6. Replace the valve guide orifice (key 2) if the seat is badly damaged. A special tool is required to replace the valve guide orifice (key 2).
7. After reassembly, pressure test for leakage and readjust the setpoint.

Type N120 Disassembly

Refer to Figure 6:

Note

Coat all new O-rings with Dow Corning silicone grease or the equivalent before reinstalling.

1. Unscrew the union nut (key 11) and remove the spring case (key 7) from the body (key 1).
2. To replace the diaphragm (key 4), remove the diaphragm assembly that includes the valve plug (key 3).

N100, N100A, N110, and N120 Series

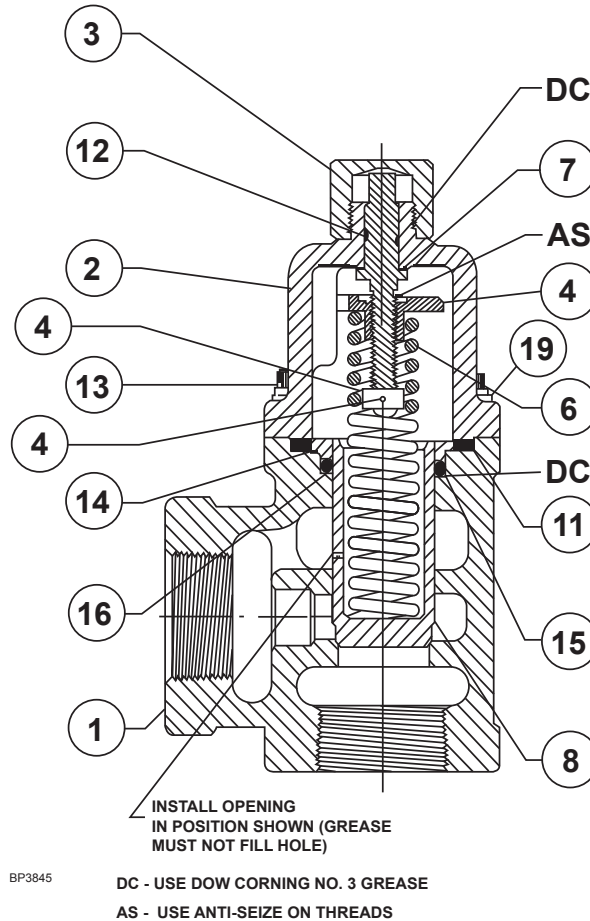

Figure 4. Types N100 and N100A Bypass Valve Assembly

3. Unscrew the nut (key 6) and remove the diaphragm head (key 5). Replace the diaphragm (key 4) and reassemble. Reassemble with loctite on the valve plug (key 3) threads.
4. To replace the O-ring seal (key 17), remove the screw (key 19) and the O-ring washer (key 18). Reinstall the screw (key 19) and O-ring washer (key 18). Place a small amount of Loctite on the screw (key 19) before reassembly and tighten.
5. Replace the valve guide orifice (key 2) if the seat is badly damaged or O-ring (key 16) is leaking. A special tool is required to replace the valve guide orifice (key 2). Replace the O-ring (key 16) and reassemble the valve guide orifice (key 2) by firmly seating into the body (key 1).
6. O-ring (key 10) can be replaced by removing the seal cap (key 12).
7. After reassembly, pressure test for leakage and readjust the setpoint.

Parts Ordering

When corresponding with your local Distributor about this equipment, include the type number and all other pertinent information printed on the label. Specify the eleven-character part number when ordering new parts from the following parts list.

Parts List

Types N100 and N100A Bypass Valve (Figure 4)

Key	Description	Part Number
1	Body, Ductile iron	
	NPS 1	2P384419232
	NPS 1-1/4	2P383219172
	NPS 1-1/2	2P382719232
	NPS 2	3R195119232
2	NPS 2-1/2	3R195219232
	Spring Case, Ductile iron	
Types N100 and N100A (NPS 1 thru 1-1/2)		1P382819172
	Type N100 (NPS 2 and 2-1/2)	2R195419272
3	Closing Cap, Aluminum	
	Types N100 and N100A (NPS 1 thru 1-1/2)	1P382947062
	Type N100 (NPS 2 and 2-1/2)	1P360809022

N100, N100A, N110, and N120 Series

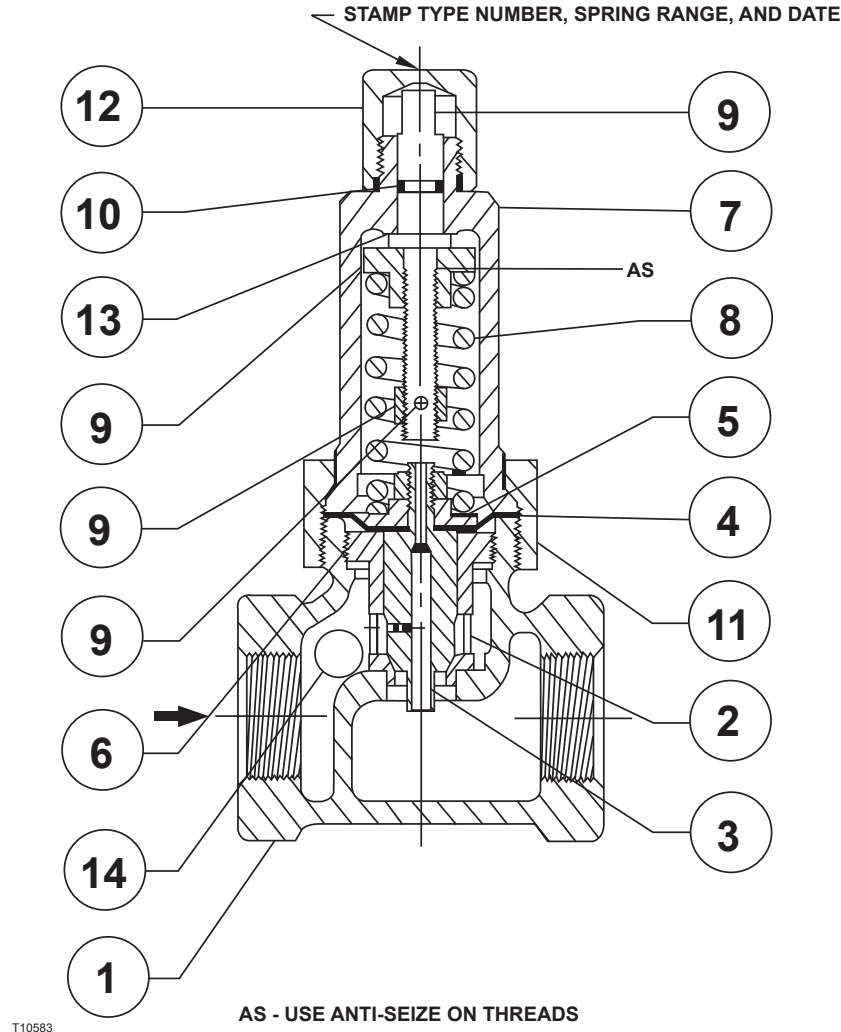

Figure 5. Type N110 Bypass Valve Assembly

Type N100 and N100A Bypass Valve (Figure 4) (continued)

Key	Description	Part Number
4	Spring Adjuster Assembly, Aluminum/Stainless steel Types N100 and N100A (NPS 1 thru 1-1/2) Type N100 (NPS 2 and 2-1/2)	1P3837000A2 1R1963000A2
6	Spring, Stainless steel NPS 1 thru 1-1/2 25 to 75 psig (1,7 to 5,2 bar) 50 to 150 psig (3,45 to 10,3 bar) NPS 2 and 2-1/2 25 to 75 psig (1,7 to 5,2 bar) 50 to 150 psig (3,5 to 10,3 bar)	1P384137022 1P383838992 1R195537022 1R1956T0012
7*	Adjusting Screw Gasket Types N100 and N100A (NPS 1 thru 1-1/2) Nylon (PA) Type N100 (NPS 2 and 2-1/2), Steel	1P383006162 1P417928992
8*	Inner Valve, Stainless steel Type N100 (NPS 1 thru 1-1/2) Type N100A (NPS 1 thru 1-1/2) Type N100 (NPS 2 and 2-1/2)	1P383546172 T1157735032 1R195746172
9	Drive Screw, 18-8 Stainless steel (2 required)	1A368228982

Key	Description	Part Number
11*	O-Ring, Nitrile (NBR) Types N100 and N100A (NPS 1 thru 1-1/2) Type N100 (NPS 2 and 2-1/2)	T12942T0012 1R195806992
12*	O-Ring, Nitrile (NBR) Types N100 and N100A (NPS 1 thru 1-1/2) Type N100 (NPS 2 and 2-1/2)	T12946T0012 T12945T0012
13	Screw, Steel (4 required) Types N100 and N100A (NPS 1 thru 1-1/2) Type N100 (NPS 2 and 2-1/2)	1V1542X0012 T12724T0012
14	Washer, Stainless steel Types N100 and N100A (NPS 1 thru 1-1/2) Type N100 (NPS 2 and 2-1/2)	1P383935132 1R196035012
15*	O-Ring, Nitrile (NBR) Types N100 and N100A (NPS 1 thru 1-1/2) Type N100 (NPS 2 and 2-1/2)	T12947T0012 T12941T0012
16*	Cap Seal, Polytetrafluoroethylene (PTFE)/Molybdenite (MoS ₂) Types N100 and N100A (NPS 1 thru 1-1/2) Type N100 (NPS 2 and 2-1/2)	1P384306442 1R196206442
17	Pipe Plug, Carbon steel	T13718T0012
19	Lock Washer, Carbon plated-steel (4 required) Types N100 and N100A (NPS 1 thru 1-1/2) Type N100 (NPS 2 and 2-1/2)	1C225728982 1A505628982

*Recommended spare part

N100, N100A, N110, and N120 Series

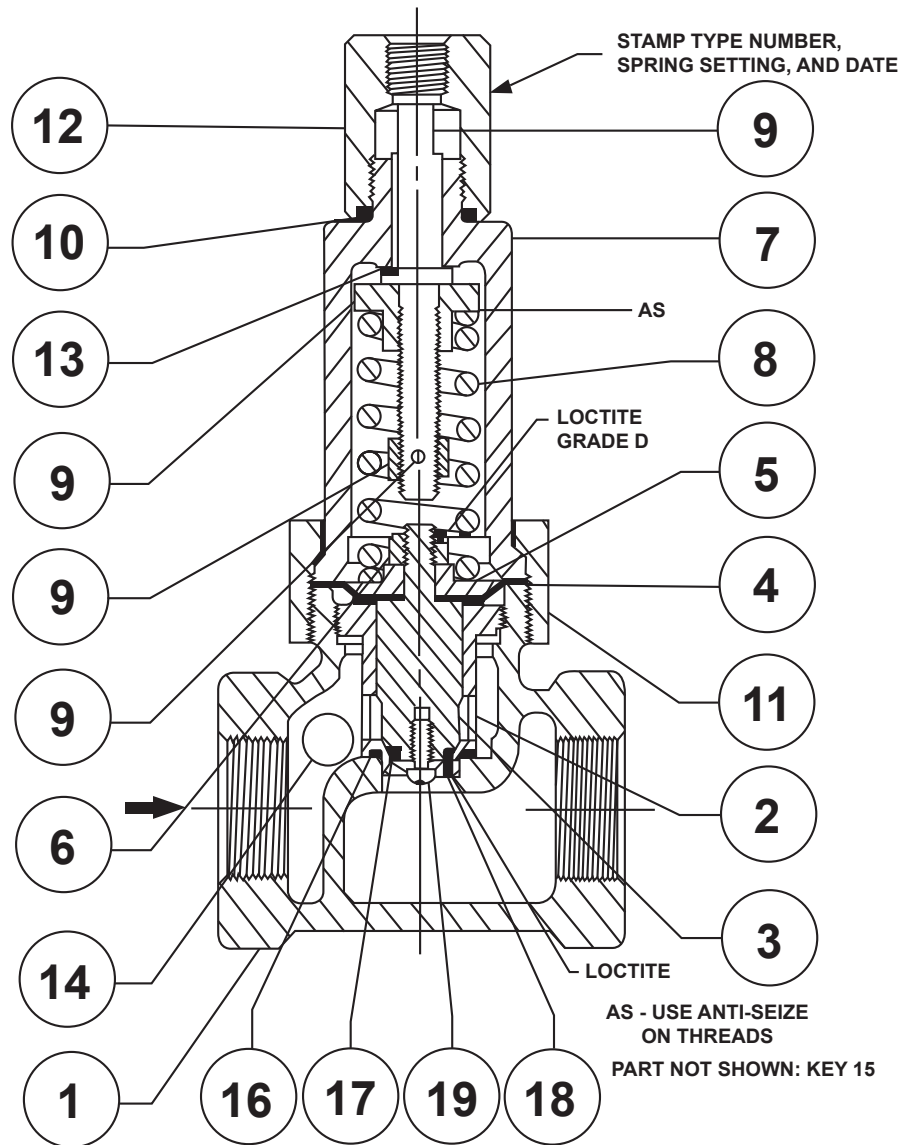

T10695

Figure 6. Type N120 Backpressure Valve Assembly

N100, N100A, N110, and N120 Series

Types N110 and N120 Bypass and Backpressure Valve (Figures 5 and 6)

Key	Description	Part Number	Key	Description	Part Number
1	Body, Ductile iron NPS 3/4 NPS 1	T1058019232 T1058419232	9	Spring Adjustment Assembly, Steel/Stainless steel Type N110 Type N120	T10579000A2 T10699000A2
2*	Valve Guide Orifice, Aluminum	T20819T0012	10*	O-Ring, Nitrile (NBR) Type N110 Type N120	T12946T0012 T1069606562
3	Valve Plug, 303 Stainless steel Type N110 Type N120	T1058135022 T1069235032	11	Union Nut, Ductile iron	1E471119062
4*	Diaphragm, Nitrile (NBR)	1E621702052	12	Seal Cap, Aluminum Type N110 Type N120	1P382947062 T1069347062
5	Diaphragm Head, Aluminum	T1057809012	13*	Washer, Nylon (PA)	1P383006162
6	Nut, Zinc-plated steel	T1059325552	14	Pipe Plug, Carbon steel	T13718T0012
7	Spring Case, Ductile iron	T1057519232	16*	O-Ring (Type N120 Only), Nitrile (NBR)	1K314806992
8	Spring, Stainless steel 25 to 75 psig (1,7 to 5,2 bar) 50 to 150 psig (3,5 to 10,3 bar) 12 psig (0,83 bar)	T1057737082 T1057637082 T1069737022	17*	O-Ring (Type N120 Only), Nitrile (NBR)	T12945T0012
			18	O-Ring Washer (Type N120 Only), 303 SST	1D335935072
			19	Machine Screw (Type N120 Only), Carbon plated-steel	16A0429X012

*Recommended spare part

LP-Gas Equipment

Emerson Process Management Regulator Technologies, Inc.

USA - Headquarters
McKinney, Texas 75070 USA
Tel: 1-800-558-5853
Outside U.S. 1-972-548-3574

For further information visit www.emersonprocess.com/regulators/lp

The Emerson logo is a trademark and service mark of Emerson Electric Co. All other marks are the property of their prospective owners. Fisher is a mark owned by Fisher Controls, Inc., a business of Emerson Process Management.

The contents of this publication are presented for informational purposes only, and while every effort has been made to ensure their accuracy, they are not to be construed as warranties or guarantees, express or implied, regarding the products or services described herein or their use or applicability. We reserve the right to modify or improve the designs or specifications of such products at any time without notice.

Emerson Process Management does not assume responsibility for the selection, use or maintenance of any product. Responsibility for proper selection, use and maintenance of any Emerson Process Management product remains solely with the purchaser.