

BRANSON



DCX Series

Ultrasonic Welding Power Supplies
for Automated Assembly Systems

DCX Compact Digital Power Supply for Integration

Maximum Power in a Minimal Footprint – superior welding results in automation.



Branson's newest evolution in ultrasonic power supplies combine scalable technology and closed loop amplitude control to provide enhanced performance, control, durability and reliability for all your automated assembly needs.

Designed specifically for ultrasonic assembly systems in the automotive, packaging, textile, and food industries, each DCX unit is backed by our proven commitment to providing superior global technology, support and service. These compact power sources provide the highest output/ per unit volume ratio of any ultrasonic power supply. With regards to weld quality, we've engineered the DCX to a whole new controls level, with industry-first closed-loop amplitude control.

Advanced features to ensure assembly efficiency and quality

- **Improved Setup and Serviceability** – Branson's exclusive BUC service port for remote diagnostics and configuration
- **More Flexible** – multiple form factors and mounting options allow easier system design and integration
- **More Efficient** – amplitude is regulated to stay constant, so less force is required to weld
- **More Productive** – programmable starting ramp times help improve cycle rate and throughput
- **More Dependable** – six levels of power supply protection helps maintain weld quality and extend product life
- **Improved Thermal Management** – separate electronics and heat management compartments increase performance and durability

In short, the DCX Digital Power Supply gives you benefits to do more, with increased power, minimized downtime, enhanced throughput, and the high, global level of technical and product support you can always expect from Branson.



True Global Support & Service

Branson Ultrasonics is the world leader in materials joining with more than 1,800 employees and 70 sales and support offices. We are committed to leading the industry in products, solutions, service and support excellence. That means fast delivery, troubleshooting, parts replacement, feasibility studies, cooperative research, preventative maintenance and repair services. Branson is part of the Industrial Automation division of Emerson, a diversified international manufacturing and technology company committed to developing technological breakthroughs that advance the performance of a wide range of products and processes.

Greater Flexibility and Control

Digital Auto-Tune with Memory (AT/M) – Provides fully-automatic tuning and storage of horn frequency for each weld.

Total Amplitude Control – Provides complete and precise amplitude control throughout the weld cycle. Amplitude can also be increased or decreased instantaneously *during* the weld – an industry first.

Constant Amplitude – Amplitude stays constant, automatically corrected for variations to ensure reproducibility of welding results. As a result, less force per weld is needed.

Six Levels of Power Supply Protection – Safeguards against over power, over current, over voltage, phase, frequency, and temperature.

CE and NRTL Approved – CE certified for operation in the EU and NRTL approved by Curtiss Straus for operation in the U.S.

High Cycle Rates – Capable in excess of 200 welds per minute. Actual cycle rate is dependent on application and controls.



Three compact DCX configurations – horizontal, vertical with side mount or rear plane mount



Set Configurations and Diagnostics from Anywhere



I/O Configuration – Assigns I/O pin numbers to control functions and logic type.



P/S Diagnostics – Analyzes horn frequencies and performance.

Whether on-site or around the world, the DCX BUC service port is a single point of access

- Test Horn / Stack Acoustics
- I/O Configuration (0V or 24V Logic) and Diagnostics
- Alarm reporting
- Setup Internet protocol
- Modify weld presets including amplitude, frequency offset and starting ramp time



Weld Preset – Sets welder control parameters such as amplitude, starting ramp, and frequency seeking.

The Branson Advantage

For more than 60 years, Branson has worked closely and innovatively with quality-focused manufacturers worldwide to solve these diverse challenges. We do so by providing the joining technologies, technical expertise, and responsive service that enable their partners to get new products to market quickly and cost-effectively. Our commitment to total quality practices has qualified our company for ISO 9001 (since 1994) and ISO 14001 (since 1998) certifications.

Request our detailed data sheet for complete specifications.

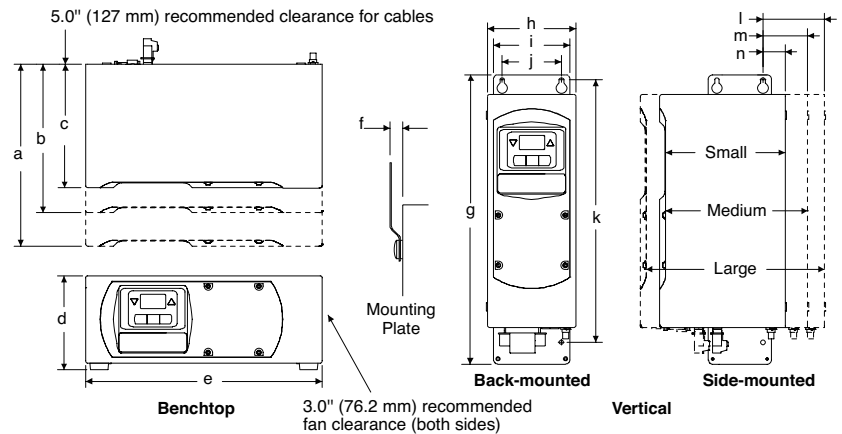

DCX Series Specifications

DIMENSION	INCH	MM	DIMENSION	INCH	MM
a	10.63	270.0	h	5.22	132.6
b	8.63	219.2	i	4.5	114.3
c	7.13	181.1	j	3.50	88.9
d	5.53	140.5	k	15.75	400.0
e	14.01	355.9	l	3.37	85.6
f	0.37	9.4	m	2.37	60.2
g	17.38	441.5	n	1.06	26.9

SIZE	SMALL	MEDIUM	LARGE
weight	16 lbs / 7.25 kg	18 lbs / 8.16 kg	22 lbs / 10 kg
watts	800 or less	801 to 1500	1501 to 4000

Note: Add 3" (76 mm) to depth for cable clearance on horizontal units. Add 3" (76 mm) to width (bottom) for cable clearance on vertical units.



Americas

Branson Ultrasonics Corp.
41 Eagle Road
Danbury, CT 06810, USA
T: 203-796-0400
F: 203-796-0450
www.bransonultrasonics.com

Europe

Branson Ultraschall
Niederlassung der Emerson
Technologies GmbH & Co. OHG
Waldstrasse 53-55
63128 Dietzenbach, Germany
T: +49-6074-497-0
F: +49-6074-497-199
www.branson.eu

Asia

Branson Ultrasonics (Shanghai) Co., Ltd.
758 Rong Le Dong Road
Song Jiang, Shanghai, PRC, 201613
T: 86-21-3781-0588
F: 86-21-5774-5100
www.branson-china.com