



Branson Ultraseal® 20 Ultrasonic Tube Welding System

The Ultraseal® 20 is a compact and lightweight ergonomic system which is easy

to use and low cost to operate.

The Branson **Ultraseal® 20** is a rigid, lightweight and ergonomic metal joining system able to seal metal tubes from 4 mm capillary up to 12 mm diameter. It is easily operated directly on the charge line, supported by a balancer, or as a bench top unit to reliably seal pressurized charge tubes.

Environmentally friendly, the **Ultraseal® 20** requires no stored energy, minimal energy at 'standby - weld ready' and, with a stack efficiency of approximately 95%, delivers the lowest total operating cost over life of ownership.

The **Ultraseal® 20** mechanically crimps the tube closed and vibrates the inner surfaces together at 20,000 cycles per second. The intense scrubbing action mixes the molecules forming a metallurgical bond ensuring a hermetic seal.

MODES OF OPERATION:

- **Pre-Height Search:** A pre-sonic crimp measurement instantly scans and automatically activates the optimum weld parameters from the controller's memory sealing the tube. This is used when tube size and/or hardness varies within a production line to produce repeatable and reliable welds.
- **Proximity Sensor:** The ultrasonic generator delivers high frequency vibratory energy sealing the tube to the preset final seal height. This is used when the tube size and hardness does not vary producing a repeatable and reliable seal.
- **Explosion Proof Ultraseal® 20EX:** Independently lab certified for use with isobutene refrigerants. A safety purge system removes potentially trapped gas from the weld actuator prior to electrical startup and remains continuously active while powered up, eliminating the potential of gas accumulation.

Metal Welding

This provides optimum production line and operator safety.

Superior Tool Life

Aside from labor, consumable tool cost is the largest expense in sealing tubes. Branson's replaceable tip technology provides high tool life at low cost.

Ultraseal® 20 Tooling Options

- > 4-lobe single seal non-cut tip
- > 4-lobe single seal cut-off tip
- > 4-lobe double seal cut-off tip
- Branson tips are reversible for left or right-handed charge tube processing.
- Only Branson offers **Patented Double Seal** tooling with left and right hand tube seal /cut-off processing without tool change.
- Ultraseal® 20 multi-lobed tips are more economical than solid horn (sonotrode) technology.
- Tip rotation can be done in less than 2 minutes for more system up-time.
- Tip replacement in approximately 4 minutes for more system up-time.
- Adjustable tube stop for longer tool life.
- Proportioned air-cooling for increased tool life.

Additional Benefits

- Five levels of quality monitoring:
 - > Weld power
 - > Weld time
 - > Tube pre-height
 - > Tube final height
 - > Height with time compensation
- Lowest maintenance cost in the industry.
- 4.0kw generators.
- Multiple languages.
- Branson worldwide technical support.
- Data capture capable.
- Adjustable maintenance counters.

- 3 level password protection.
- Remote operator panel - option available.
- Automation or robotic operation capable.
- Automatic spares replenishment program.
- Over 25 years of industry experience.

Operating Specifications

- Electrical: 245V AC, 50/60 Hz, 1, 15 amp.
- Pneumatic: 5.5 bar (80 psig) clean, dry (0.5µm coalescing filter) air.
- Actuator weight: 10.9 kg (24 lbs.).

DIMENSIONS

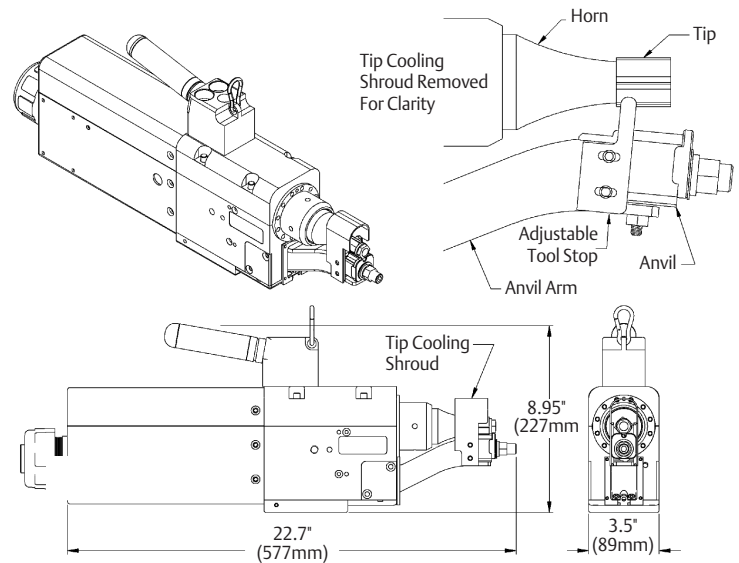

BRANSON

Branson Ultrasonics Corporation
 41 Eagle Road, Danbury, CT 06813-1961
 (203) 796-0400 • Fax: (203) 796-9838
 www.bransonultrasonics.com
 e-mail: info@bransonultrasonics.com

Ultraseal® 20 © Branson Ultrasonics Corporation 2011
 The Emerson logo is a trademark and service mark of Emerson Electric Co.
 Revised and printed in the U.S.A. 9/2011