

## Introduction

This installation guide provides instructions for installation, startup, and adjustment. To receive a copy of the instruction manual, contact your local Sales Office or view a copy at [www.fisherregulators.com](http://www.fisherregulators.com). For further information refer to: Type 167D Series Instruction Manual, Form 5859, D103234X012.

## P.E.D. Category

This product may be used as a safety accessory with pressure equipment in the following Pressure Equipment Directive 97/23/EC categories. It may also be used outside of the Pressure Equipment Directive using sound engineering practice (SEP) per table below.

PRODUCT SIZE	CATEGORIES	FLUID TYPE
1/4 or 1/2 NPT	SEP	1

## Specifications

### Available Configurations

**Types 167D and 167DS:** Two-way switching valves

**Types 167DA and 167DAS:** Three-way switching valves

### Body Size, Inlet and Outlet Connection Style

**Ports A and C:** 1/4 or 1/2 NPT

**Vent and Control Pressure Connections (Port D) and Port B:** 1/4 NPT

### Outlet Pressure Ranges<sup>(1)</sup>

**Types 167D and 167DS (Two-Way Switching Valves):**

*Port A as Inlet:*

0,21 to 1,0 bar / 3 to 15 psig<sup>(2)</sup>

0,34 to 1,4 bar / 5 to 20 psig

0,34 to 2,4 bar / 5 to 35 psig

1,7 to 4,1 bar / 25 to 60 psig

2,8 to 8,6 bar / 40 to 125 psig

3,4 to 10,3 bar / 50 to 150 psig<sup>(3)</sup>

**Types 167DA and 167DAS (Three-Way Switching Valves):**

*Port A or C as Inlet:*

0,97 to 1,4 bar / 14 to 20 psig

1,1 to 2,4 bar / 16 to 35 psig

1,7 to 4,1 bar / 25 to 60 psig

2,8 to 8,6 bar / 40 to 125 psig

*Port B as Inlet:*

0,48 to 1,4 bar / 7 to 20 psig

0,69 to 2,1 bar / 10 to 30 psig

1,7 to 3,4 bar / 25 to 50 psig

2,8 to 6,2 bar / 40 to 90 psig

### Maximum Operating Inlet Pressure<sup>(1)</sup>

**Types 167D and 167DS:** 27,6 bar / 400 psig

**Types 167DA and 167DAS:** 8,6 bar / 125 psig

**Types 167DA and 167DAS (NACE):** 6,9 bar / 100 psig

### Maximum Diaphragm Pressure<sup>(1)</sup>

10,3 bar / 150 psig over outlet pressure setting up to a maximum of 17,2 bar / 250 psig

### Proof Test Pressure

All Pressure Retaining Components have been proof tested per Directive 97/23/EC - Annex 1, Section 7.4

### Temperature Capabilities<sup>(1)</sup>

#### Nitrile (NBR)

*Standard Service (Types 167D and 167DA only):*

-29° to 82°C / -20° to 180°F

*Low Temperature Service (Types 167D and 167DA only) and Standard Service (Types 167DS and 167DAS only):*

-40° to 82°C / -40° to 180°F

#### Fluorocarbon (FKM)

*High Temperature Service:* -18° to 149°C / 0° to 300°F

## Installation



### WARNING

Only qualified personnel should install or service a switching valve. Switching valves should be installed, operated, and maintained in accordance with international and applicable codes and regulations, and Emerson Process Management Regulator Technologies, Inc. instructions.

If the switching valve vents fluid or a leak develops in the system, it indicates that service is required. Failure to take the switching valve out of service immediately may create a hazardous condition.

Personal injury, equipment damage, or leakage due to escaping fluid or bursting of pressure-containing parts may result if this switching valve is overpressured or is installed where service conditions could exceed the limits given in the Specifications section, or where conditions exceed any ratings of the adjacent piping or piping connections.

1. The pressure/temperature limits in this Installation Guide and any applicable standard or code limitation should not be exceeded.  
2. For Type 167D only  
3. For Type 167DS only.



# 167D Series

To avoid such injury or damage, provide pressure-relieving or pressure-limiting devices (as required by the appropriate code, regulation, or standard) to prevent service conditions from exceeding limits.

Additionally, physical damage to the switching valve could result in personal injury and property damage due to escaping fluid. To avoid such injury and damage, install the switching valve in a safe location.

Clean out all pipelines before installation of the switching valve and check to be sure the switching valve has not been damaged or has collected foreign material during shipping. For NPT bodies, apply pipe compound to the external pipe threads. Install the switching valve in any position desired, unless otherwise specified, but be sure flow through the body is in the direction indicated by the arrow on the body.

## Note

It is important that the switching valve be installed so that the vent hole in the spring case is unobstructed at all times. For outdoor installations, the switching valve should be located away from vehicular traffic and positioned so that water, ice, and other foreign materials cannot enter the spring case through the vent. Avoid placing the switching valve beneath eaves or downspouts, and be sure it is above the probable snow level.

## Overpressure Protection

The recommended pressure limitations are stamped on the switching valve nameplate. Some type of overpressure protection is needed if the actual inlet pressure exceeds the maximum operating outlet pressure rating. Overpressure protection should also be provided if the switching valve inlet pressure is greater than the safe working pressure of the downstream equipment.

Switching valve operation below the maximum pressure limitations does not preclude the possibility of damage from external sources or debris in the line. The switching valve should be inspected for damage after any overpressure condition.

\*Recommended spare part.

## Startup

The switching valve is factory set at approximately the midpoint of the spring range or at the pressure setting specified on the order. The allowable spring range is stamped on the nameplate. If a pressure setting other than specified is desired, be sure to change the pressure setting by following the proper procedure as mentioned in the Adjustment section. With proper installation completed and relief valves properly adjusted, slowly open the upstream and downstream shut-off valves.

## Adjustment

If outlet pressure adjustment is necessary, monitor outlet pressure with a gauge during the adjustment procedure. The switching valve is adjusted by loosening the hex nut, if used, and turning the adjusting screw or handwheel clockwise to increase or counterclockwise to decrease the outlet pressure setting. Retighten the hex nut to maintain the adjustment position.

## Taking Out of Service (Shutdown)



To avoid personal injury resulting from sudden release of pressure, isolate the switching valve from all pressure before attempting disassembly.

## Parts List

### 167D Series

Key	Description
1	Body
3	Flange Screw
7	Spring Case Assembly
11	Valve Stem
12*	Valve Spring
14*	O-ring (Spring Retainer)
15	Soft Seat (for Types 167D and 167DS only)
16*	Diaphragm Assembly
17	Control Spring
18	Adjusting Screw
19	Hex Nut
20	Upper Spring Seat
23	1/4 NPT Pipe Plug
30	NACE Tag (not shown)
31	Panel Mounting Nut
32	Wire Seal (not shown)
33	Closing Cap
45	Screen Vent (for Types 167DS and 167DAS only)
48	Spring Retainer
50*	O-ring (Stem and Plug)
57	Valve Plug
58*	Seat
64	Retaining Ring

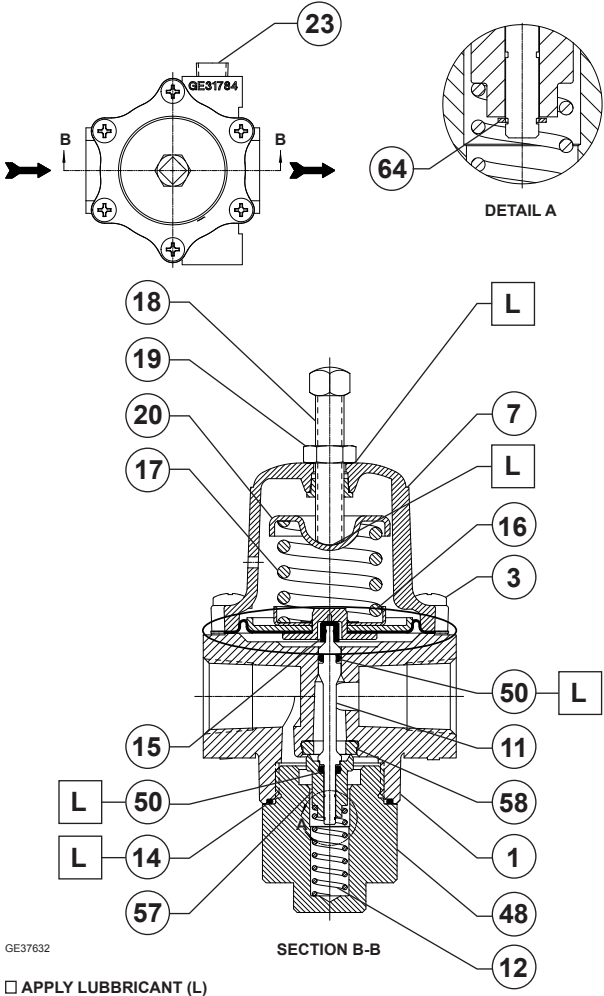

Figure 1. Type 167D Assembly

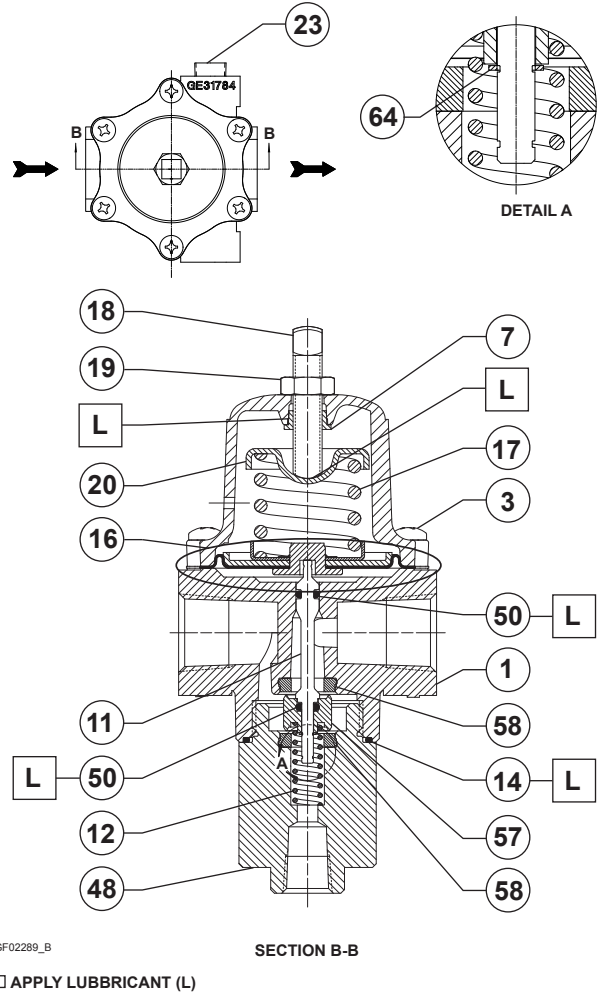

Figure 2. Type 167DA Assembly

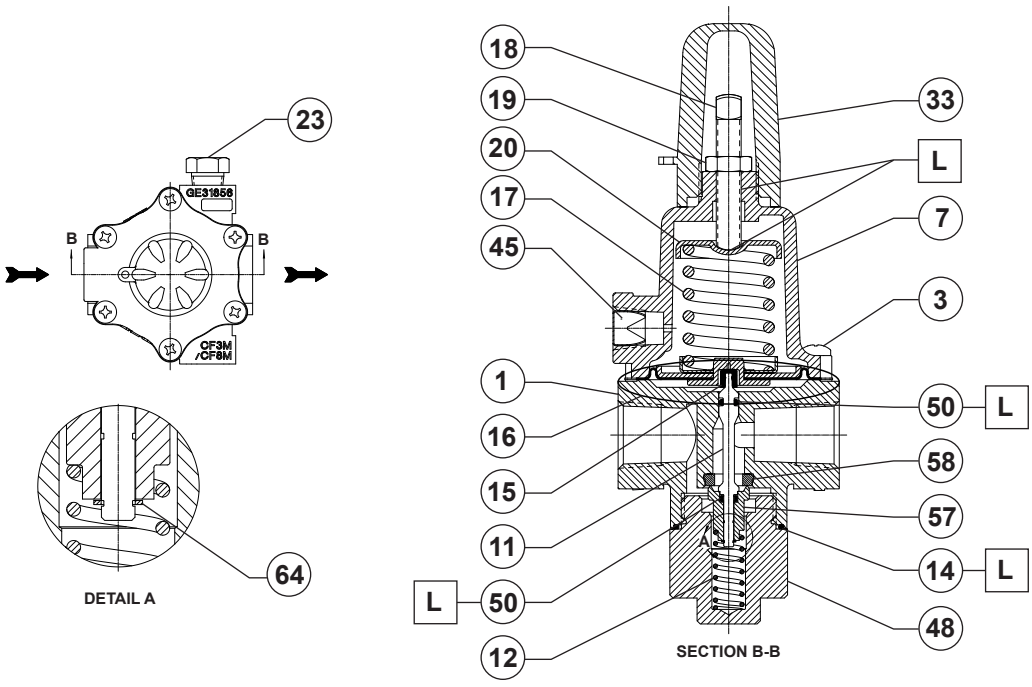
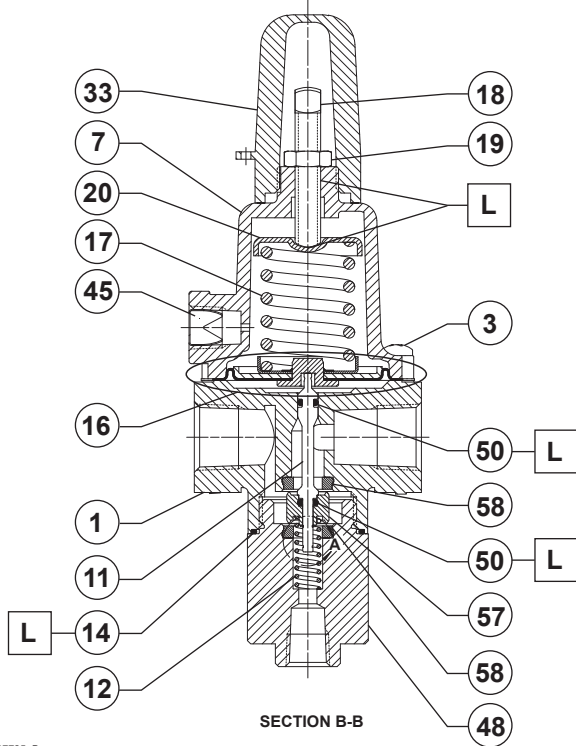
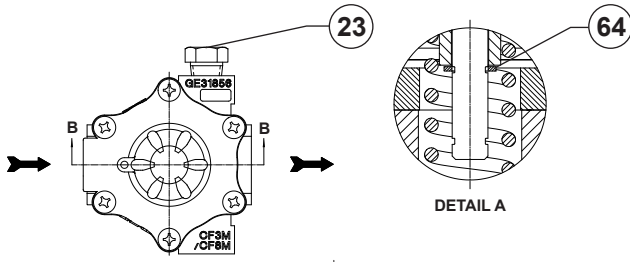

Figure 3. Type 167DS Assembly

# 167D Series



GE37725\_B  
 □ APPLY LUBRICANT (L)

**Figure 4. Type 167DAS Assembly**

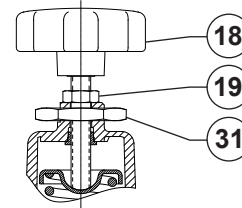

**Figure 5. Optional Panel Mount**

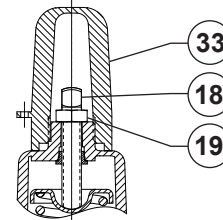

**Figure 6. Optional Closing Cap**  
 (Only Available with the 1/4 NPT Spring Case Vent)

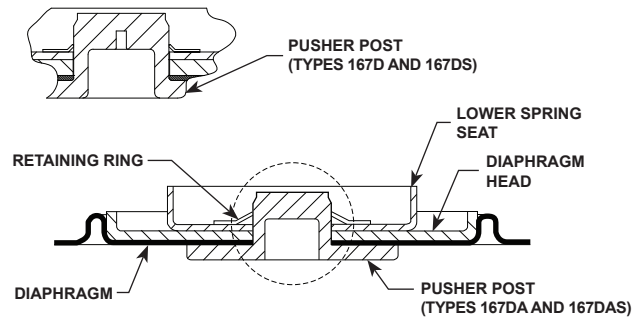

T14119\_B

**Figure 7. Detail of Diaphragm Assembly (Key 16)**

## Industrial Regulators

### Emerson Process Management Regulator Technologies, Inc.

USA - Headquarters  
 McKinney, Texas 75069-1872, USA  
 Tel: +1 800 558 5853  
 Outside U.S. +1 972 548 3574

Asia-Pacific  
 Shanghai 201206, China  
 Tel: +86 21 2892 9000

Europe  
 Bologna 40013, Italy  
 Tel: +39 051 419 0611

Middle East and Africa  
 Dubai, United Arab Emirates  
 Tel: +971 4811 8100

## Natural Gas Technologies

### Emerson Process Management Regulator Technologies, Inc.

USA - Headquarters  
 McKinney, Texas 75069-1872, USA  
 Tel: 1 800 558 5853  
 Outside U.S. 1 972 548 3574

Asia-Pacific  
 Singapore 128461, Singapore  
 Tel: +65 6777 8211

Europe  
 Bologna 40013, Italy  
 Tel: +39 051 419 0611  
 Gallardon 28320, France  
 Tel: +33 2 37 33 47 00

## TESCOM

### Emerson Process Management Tescom Corporation

USA - Headquarters  
 Elk River, Minnesota 55330-2445, USA  
 Tel: +1 763 241 3238  
 +1 800 447 1250

Europe  
 Selmsdorf 23923, Germany  
 Tel: +49 38823 31 287

Asia-Pacific  
 Shanghai 201206, China  
 Tel: +86 21 2892 9499

For further information visit [www.fisherregulators.com](http://www.fisherregulators.com)

The Emerson logo is a trademark and service mark of Emerson Electric Co. All other marks are the property of their prospective owners. Fisher is a mark owned by Fisher Controls, Inc., a business of Emerson Process Management.

The contents of this publication are presented for informational purposes only, and while every effort has been made to ensure their accuracy, they are not to be construed as warranties or guarantees, express or implied, regarding the products or services described herein or their use or applicability. We reserve the right to modify or improve the designs or specifications of such products at any time without notice.

Emerson Process Management does not assume responsibility for the selection, use or maintenance of any product. Responsibility for proper selection, use and maintenance of any Emerson Process Management product remains solely with the purchaser.



**EMERSON**  
 Process Management