

1805 Series Relief Valves



Type 1805-2



Type 1805-4

Figure 1. Typical 1805 Relief Valves

Introduction

The 1805 Series relief valves are designed for use in farm tap applications where a safety relief valve is needed between the first and second stage regulators. The 1805 Series is suitable for natural gas, air, propane, or any operating medium that is not corrosive to the internal parts. Relief pressures range from 5 to 125 psig / 0,34 to 8,6 bar. Maximum pressure, including buildup, is 150 psig / 10,3 bar.

Features

- **Tight Shutoff**—Provided by the Nitrile (NBR) O-ring and O-ring seat.

- **Easy Maintenance**—The union nut allows quick removal of the cage assembly for trim inspection. The valve can be back in operation in a matter of minutes.
- **Simple Adjustment**—A single adjusting screw is used to meet individual application requirements.
- **Complete Venting**—A closing cap is available if all venting must be piped away.
- **Sour Gas Service Capability**—Optional materials are available for applications handling sour gases. These constructions comply with the recommendations of the NACE International Standards MR0175 and MR0103.

Bulletin 71.4:1805

Specifications

Available Constructions

See Table 2

Body Style

Globe body

Body Sizes and End Connection Style

3/4, 1, 1-1/2, or 2 NPT

Maximum Inlet Pressure⁽¹⁾

150 psig / 10,3 bar including buildup

Relief Valve Set Pressure Ranges

See Table 1

Flow and IEC Sizing Coefficients

See Table 3

Temperature Capabilities⁽¹⁾

-20° to 150°F / -29° to 66°C

Construction Materials

Body: Cast Iron (all sizes) and Ductile Iron (NACE)
(3/4 and 1 NPT body sizes)

Diaphragm: Nitrile (NBR)

Valve Guide Orifice: Aluminum

O-Ring Washer: Stainless steel

O-Rings: Nitrile (NBR)

O-Ring Holder: Aluminum

Diaphragm Plate: Brass

Upper Spring Seat: Plated steel

Union Nut: Ductile Iron

Vent Screen: Stainless steel

Approximate Weights

3/4 to 1 NPT bodies: 5 pounds / 2 kg

1-1/2 to 2 NPT bodies: 13 pounds / 6 kg

1. The pressure/temperature limits in this Bulletin or any applicable standard limitation should not be exceeded.

Table 1. Relief Valve Set Pressure Ranges

BODY SIZE, NPT	RELIEF PRESSURE RANGE		SPRING PART NUMBER	SPRING COLOR CODE	SPRING FREE LENGTH		SPRING WIRE DIAMETER	
	psig	bar			Inches	mm	Inches	mm
3/4 or 1	5 to 35	0,34 to 2,4	1B986027212	Green	2.25	57,2	0.12	3,05
	10 to 60	0,69 to 4,1	1B788327022	Silver	2.13	54,1	0.14	3,56
	20 to 125	1,4 to 8,6	1B788427022	Blue	1.94	49,3	0.18	4,57
1-1/2 or 2	5 to 20	0,34 to 1,4	1D892327022	Red	2.94	74,7	0.17	4,32
	10 to 50	0,69 to 3,4	1D665927022	Blue	2.50	63,5	0.22	5,59
	35 to 125	2,4 to 8,6	1E543627142	Yellow	2.31	58,7	0.28	7,11

Table 2. Available Constructions

TYPE NUMBER	BODY SIZE AND END CONNECTION, NPT	DISTINCTIVE CONSTRUCTION FEATURES
1805-2	3/4 or 1	Cast iron spring case, closing cap with 1/4 NPT vent placed over the adjusting screw
1805-3	1-1/2 or 2	Cast iron spring case, closing cap with 1/4 NPT vent placed over the adjusting screw
1805-4	3/4 or 1	Cast iron spring case
1805-5	1-1/2 or 2	Cast iron spring case
1805-7	3/4 or 1	Cast iron spring case, closing cap with 1/4 NPT vent placed over the adjusting screw, and screen in outlet

Table 3. Flow and IEC Sizing Coefficients

BODY SIZE, NPT	C _i	K _m	IEC SIZING COEFFICIENTS		
			X _T	F _D	F _L
3/4 to 1	35	0.79	0.73	0.39	0.89
1-1/2 to 2			0.94	0.44	

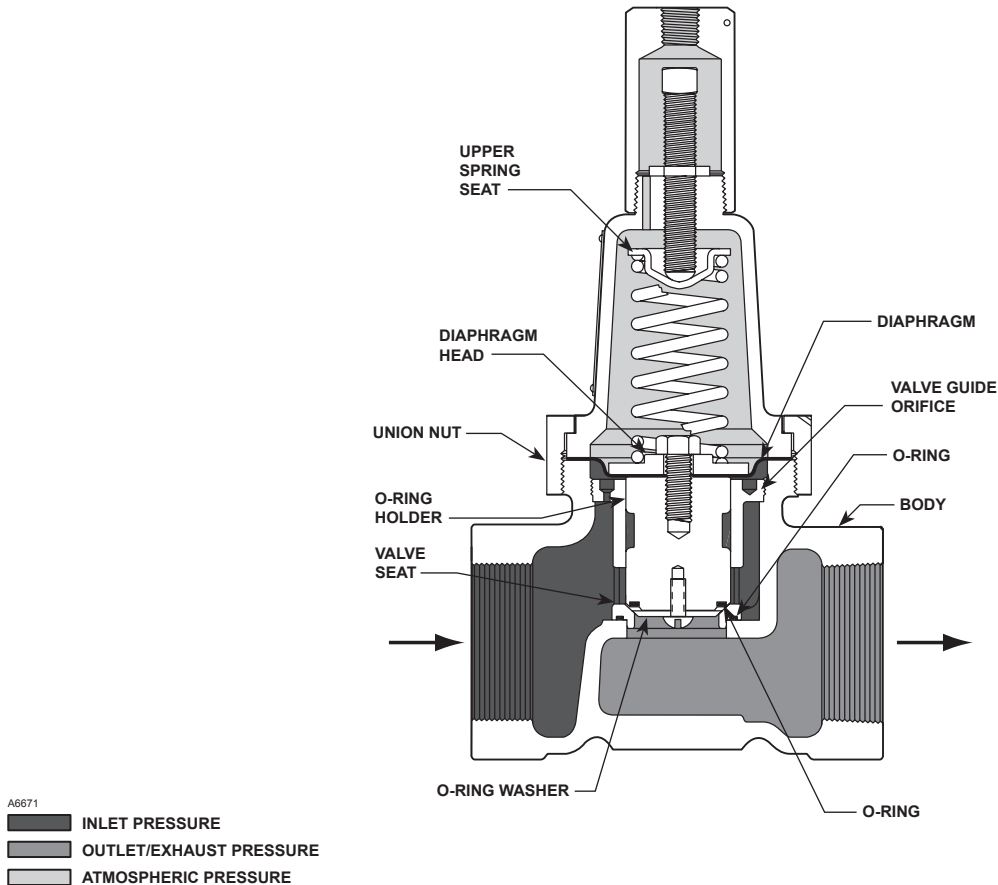

Figure 2. 1805 Series Operational Schematic

Principle of Operation

See Figure 2. Relief valves respond to changes in upstream pressure. If upstream pressure increases and exceeds the relief valve setting, the valve will open and allow gas to vent to the atmosphere. When upstream pressure returns to normal level (below the setting of the relief valve), the relief valve automatically closes and normal system operation resumes.

In the 1805 Series relief valves, the upstream pressure registers underneath the diaphragm. Gas reaches the diaphragm through the space between the O-ring holder and the valve guide orifice in 3/4 and 1 NPT bodies or through registration holes in the valve guide orifice in 1-1/2 and 2 NPT bodies.

When the upstream pressure increases beyond the spring setting, the force underneath the diaphragm overcomes spring compression. The O-ring holder moves upward, carrying the O-ring away from the valve seat. This opens the flow line, allows gas to flow to the atmosphere, and relieves the overpressure condition. When upstream pressure registered on the diaphragm decreases to a level below that of the spring setting of the relief valve, the spring force pushes the diaphragm plate and O-ring holder toward the valve seat. Contact between O-ring and valve seat prevents further flow to atmosphere.

3/4 AND 1 NPT BODIES

1-1/2 AND 2 NPT BODIES

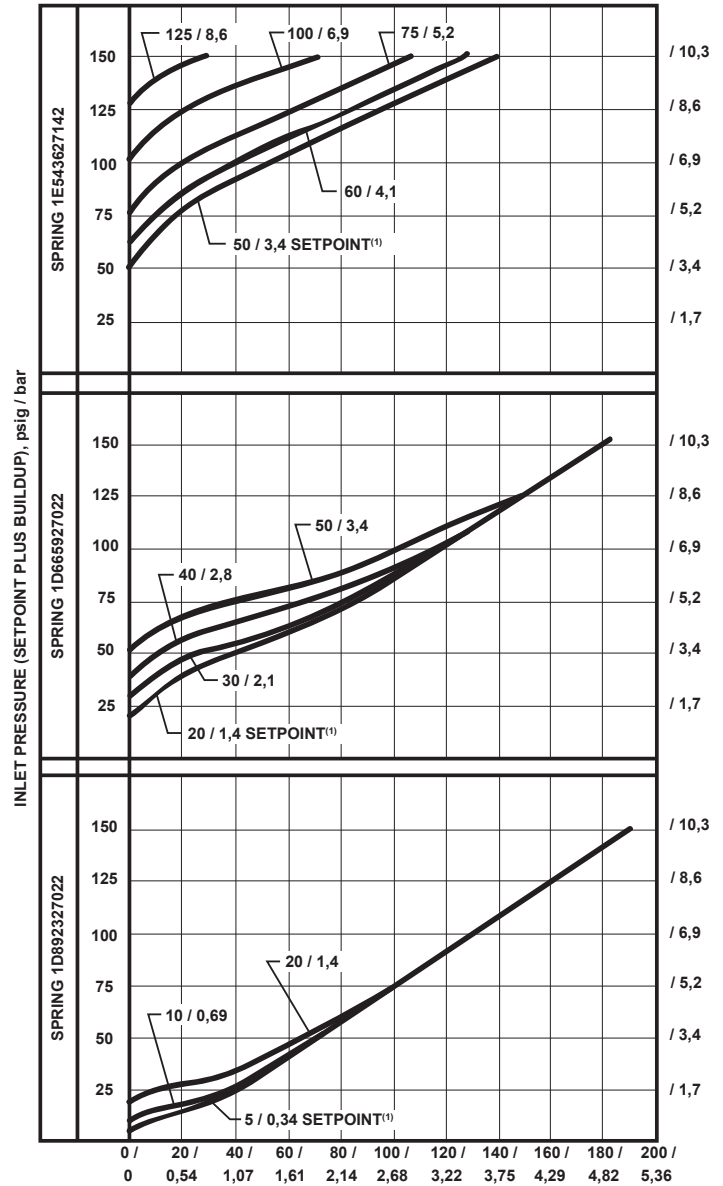
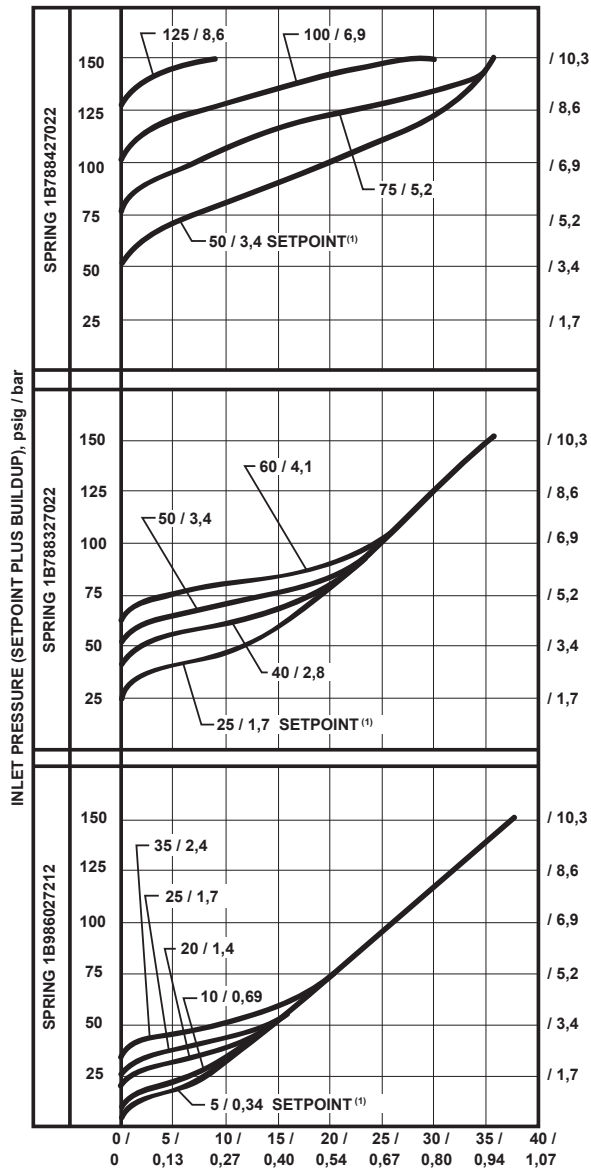

B0812

CAPACITY IN THOUSAND SCFH, AT 60°F AND 14.7 psia /
Nm³/h, AT 0°C AND 1,01325 bar OF 0.6 SPECIFIC GRAVITY
NATURAL GAS

1. SETPOINT IS TO BE INTERPRETED AS BUBBLE POINT
*MAXIMUM PRESSURE INCLUDING BUILDUP - 150 psig / 10,3 bar AT 150°F / 66°C.

Figure 3. Relief Capacity Curves

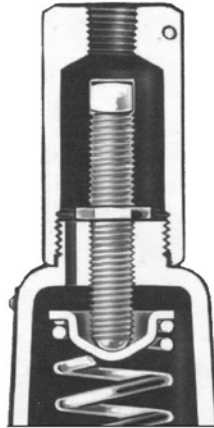

W1258

Figure 4. Type 1805-3 Closing Cap Sectional View

Installation

The 1805 Series relief valves may be installed in any position. However, the outlet connection and vents must be protected against the entrance of rain, snow, insects, or any other foreign material that may plug the outlet or affect the opening and closing of the valve. If it is necessary to pipe away the outlet, remove the outlet screen (if one is present).

Flow through the valve must be as indicated by the flow direction arrow on the body. For dimensional information, see Figure 5.

Capacity Information

Natural gas relieving capacities at selected inlet pressures (setpoint plus buildup) are given in Figure 3. Flows are in thousands SCFH (60°F and 14.7 psia) of 0.6 specific gravity natural gas. To determine the equivalent capacities for other gases, multiply the capacity obtained from the curves by the following appropriate conversion factor: 0.775 for air, 0.789 for nitrogen, 0.625 for propane, or 0.548 for butane. For gases of other specific gravities, multiply the given capacity by 0.775, and divide by the square root of the appropriate specific gravity.

Then, if capacity is desired in normal cubic meters per hour (Nm³/h) at 0°C and 1,01325 bar, multiply values obtained from Figure 3 by 0.0268.

Overpressure

Relief pressure ratings are from 5 to 125 psig / 0,34 to 8,6 bar. The maximum inlet pressure, including buildup, is 150 psig / 10,3 bar. System operation within these limitations does not eliminate the possibility of damage from external sources or from debris in the gas line. The relief valve should be inspected for damage regularly and after any overpressure condition.

Universal NACE Compliance

Optional materials are available for applications handling sour gases. These constructions comply with the recommendations of NACE International sour service standards.

The manufacturing processes and materials used by Emerson assure that all products specified for sour gas service comply with the chemical, physical, and metallurgical requirements of NACE MR0175 and/or NACE MR0103. Customers have the responsibility to specify correct materials. Environmental limitations may apply and shall be determined by the user.

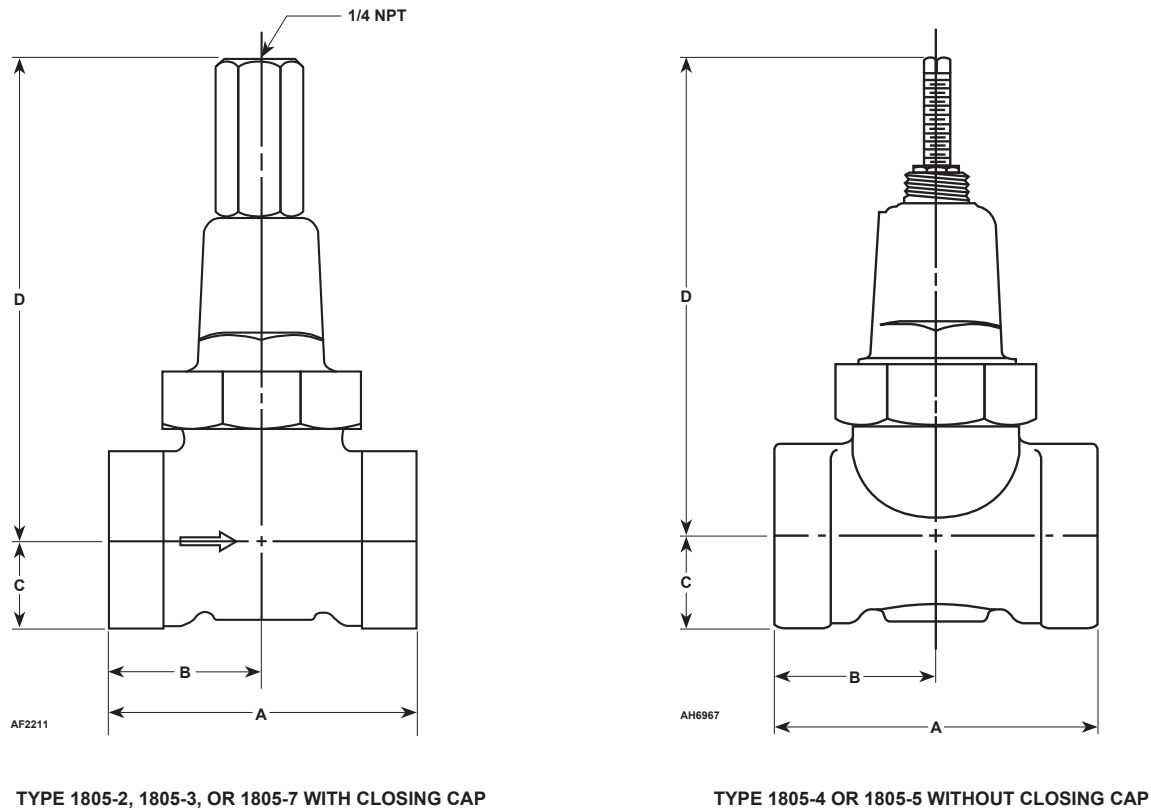

Figure 5. 1805 Series Dimensional Drawings

Table 4. 1805 Series Dimensions

TYPES	BODY SIZE AND END CONNECTION STYLE, NPT	MATERIAL	DIMENSION, INCHES / mm			
			A	B	C	D / max
1805-2 ¹ 1805-4 1805-7 ¹	3/4	Cast iron	3.62 / 92	1.81 / 46	1.00 / 25	6.44 / 164
		Ductile iron / NACE	3.88 / 99	1.94 / 49	1.38 / 35	6.44 / 164
	1	Cast iron	3.62 / 92	1.81 / 46	1.00 / 25	6.44 / 164
		Ductile iron / NACE	3.88 / 99	1.94 / 49	1.38 / 35	6.44 / 164
1805-3 ¹ 1805-5	1-1/2	Cast iron	5.88 / 149	2.94 / 75	1.69 / 43	9.12 / 232
	2	Cast iron	5.88 / 149	2.94 / 75	1.69 / 43	9.12 / 232

1. With closing cap.

Ordering Information

Please give the following information when ordering any of the 1805 Series relief valves:

1. Type Number
2. Body Size and Material
3. Desired Relief Pressure Range

Ordering Guide

Type (Refer to Table 2 for Construction Features) (Select One)

- 1805-2***
- 1805-3***
- 1805-4**
- 1805-5***
- 1805-7***

Body Size and End Connection Style (Select One)

- 3/4 NPT***
- 1 NPT***
- 1-1/2 NPT**
- 2 NPT***

Body Material (Select One)

- Cast Iron (All sizes)**
- Ductile Iron (NACE) (3/4 or 1 NPT body size only)**

Relief Set Pressure Range (Select One)

3/4 or 1 NPT Body Size:

- 5 to 35 psig / 0,34 to 2,4 bar, Green***
- 10 to 60 psig / 0,69 to 4,1 bar, Silver***
- 20 to 125 psig / 1,4 to 8,6 bar, Blue***

1-1/2 or 2 NPT Body Size:

- 5 to 20 psig / 0,34 to 1,4 bar, Red***
- 10 to 50 psig / 0,69 to 3,4 bar, Blue***
- 35 to 125 psig / 2,4 to 8,6 bar, Yellow***

Replacement Parts Kit (Optional)

- Yes, send one replacement parts kit to match this order

Regulators Quick Order Guide	
***	Readily Available for Shipment
**	Allow Additional Time for Shipment
*	Special Order, Constructed from Non-Stocked Parts. Consult your local Sales Office for Availability.
Availability of the product being ordered is determined by the component with the longest shipping time for the requested construction.	

Specification Worksheet	
Application:	
Specific Use	_____
Line Size	_____
Gas Type and Specific Gravity	_____
Gas Temperature	_____
Relief Valve Size:	
Brand of upstream regulator?	_____
Orifice size of the upstream regulator?	_____
Wide-open coefficient of the upstream regulator?	_____
Pressure:	
Maximum Inlet Pressure (P_{1max})	_____
Minimum Inlet Pressure (P_{1min})	_____
Downstream Pressure Setting(s) (P_2)	_____
Maximum Flow (Q_{max})	_____
Performance Required:	
Accuracy Requirements?	_____
Need for Extremely Fast Response?	_____
Other Requirements: _____	

Industrial Regulators

Emerson Process Management Regulator Technologies, Inc.

USA - Headquarters
McKinney, Texas 75069-1872, USA
Tel: +1 800 558 5853
Outside U.S. +1 972 548 3574

Asia-Pacific
Shanghai 201206, China
Tel: +86 21 2892 9000

Europe
Bologna 40013, Italy
Tel: +39 051 419 0611

Middle East and Africa
Dubai, United Arab Emirates
Tel: +971 4811 8100

Natural Gas Technologies

Emerson Process Management Regulator Technologies, Inc.

USA - Headquarters
McKinney, Texas 75069-1872, USA
Tel: +1 800 558 5853
Outside U.S. +1 972 548 3574

Asia-Pacific
Singapore 128461, Singapore
Tel: +65 6770 8337

Europe
Bologna 40013, Italy
Tel: +39 051 419 0611
Gallardon 28320, France
Tel: +33 2 37 33 47 00

TESCOM

Emerson Process Management Tescom Corporation

USA - Headquarters
Elk River, Minnesota 55330-2445, USA
Tels: +1 763 241 3238
+1 800 447 1250

Europe
Selmsdorf 23923, Germany
Tel: +49 38823 31 287

Asia-Pacific
Shanghai 201206, China
Tel: +86 21 2892 9499

For further information visit www.fisherregulators.com

The Emerson logo is a trademark and service mark of Emerson Electric Co. All other marks are the property of their prospective owners. Fisher is a mark owned by Fisher Controls International LLC, a business of Emerson Process Management.

The contents of this publication are presented for informational purposes only, and while every effort has been made to ensure their accuracy, they are not to be construed as warranties or guarantees, express or implied, regarding the products or services described herein or their use or applicability. We reserve the right to modify or improve the designs or specifications of such products at any time without notice.

Emerson Process Management does not assume responsibility for the selection, use or maintenance of any product. Responsibility for proper selection, use and maintenance of any Emerson Process Management product remains solely with the purchaser.