

DANIEL JUNIOR[®] ORIFICE FITTINGS

10" THROUGH 42"

PARTS LIST AND MATERIALS, INSTRUCTIONS
FOR INSTALLATION, OPERATION
AND MAINTENANCE

DANIEL MEASUREMENT AND CONTROL, INC.
AN EMERSON PROCESS MANAGEMENT COMPANY
HOUSTON, TEXAS

Part Number 3-9008-009
Revision D

OCTOBER 2014



This page intentionally left blank.

IMPORTANT INSTRUCTIONS

Daniel Measurement and Control, Inc. (Daniel) designs, manufactures and tests products to function within specific conditions. Because these products are sophisticated technical instruments, it is important that the owner and operation personnel must strictly adhere both to the information printed on the product nameplate and to all instructions provided in this manual prior to installation, operation, and maintenance.



Installing, operating or maintaining a Daniel Product improperly could lead to serious injury or death from explosion or exposure to dangerous substances. Comply with all information on the product, in this manual, and in any local and national codes that apply to the product. Do not allow untrained personnel to work with this product. Use Daniel parts and work procedures specified in this manual.

Daniel also urges you to integrate this manual into your training and safety program.

**BE SURE ALL PERSONNEL READ AND FOLLOW THE INSTRUCTIONS
IN THIS MANUAL AND ALL PRODUCT WARNINGS.**

Product Owners (Purchasers):

1. Use the correct product for the environment and pressures present. If you are unsure, discuss your needs with your Daniel representative.
2. Inform and educate all personnel in the proper installation, operation, and maintenance of this product.
3. To ensure proper performance, only informed and trained personnel should install, operate, repair and maintain this product.
4. Save this instruction manual for future reference.
5. If you resell or transfer this product, it is your responsibility to forward this instruction manual along with the product to the new owner or transferee.

Product Operation Personnel (Personnel):

1. Read and understand all instructions and operating procedures for this product.
2. Install this product as specified in the INSTALLATION section of this manual per applicable local and national codes.
3. Follow all warnings, cautions, and notices marked on, and supplied with, this product.
4. Follow all instructions during the installation, operation, and maintenance of this product.
5. To prevent personal injury, ensure that all components are in place prior to and during operation of the product.
6. Connect all products to the proper electrical and pressure sources when and where applicable.

7. If you do not understand an instruction, or do not feel comfortable following the instructions, contact your Daniel representative for clarification or assistance.
8. If this instruction manual is not the correct manual for your Daniel product, telephone Daniel at 1-713-827-6314 and Daniel will provide you with the requested manual. You may also download the correct manual from <http://www.daniel.com>.
9. Use only replacement parts specified by Daniel. Unauthorized parts and procedures can affect this product's performance, safety, and invalidate the warranty. "Look-a-like" substitutions may result in deadly fire, explosion, release of toxic substances or improper operation.
10. Save this instruction manual for future reference.

**DANIEL JUNIOR® ORIFICE FITTINGS
10" THROUGH 42"**

**PARTS LIST AND MATERIALS, INSTRUCTIONS
FOR INSTALLATION, OPERATION AND MAINTENANCE**

NOTICE

THE CONTENTS OF THIS PUBLICATION ARE PRESENTED FOR INFORMATIONAL PURPOSES ONLY, AND WHILE EVERY EFFORT HAS BEEN MADE TO ENSURE THEIR ACCURACY, THEY ARE NOT TO BE CONSTRUED AS WARRANTIES OR GUARANTEES, EXPRESSED OR IMPLIED, REGARDING THE PRODUCTS OR SERVICES DESCRIBED HEREIN OR THEIR USE OR APPLICABILITY. ALL SALES ARE GOVERNED BY DANIEL'S TERMS AND CONDITIONS, WHICH ARE AVAILABLE UPON REQUEST. WE RESERVE THE RIGHT TO MODIFY OR IMPROVE THE DESIGNS OR SPECIFICATIONS OF SUCH PRODUCTS AT ANY TIME.

DANIEL DOES NOT ASSUME RESPONSIBILITY FOR THE SELECTION, USE OR MAINTENANCE OF ANY PRODUCT. RESPONSIBILITY FOR PROPER SELECTION, USE AND MAINTENANCE OF ANY DANIEL PRODUCT REMAINS SOLELY WITH THE PURCHASER AND END-USER.

TO THE BEST OF DANIEL'S KNOWLEDGE THE INFORMATION HEREIN IS COMPLETE AND ACCURATE. DANIEL MAKES NO WARRANTIES, EXPRESSED OR IMPLIED, INCLUDING THE IMPLIED WARRANTIES OF MERCHANTABILITY AND FITNESS FOR A PARTICULAR PURPOSE WITH RESPECT TO THIS MANUAL AND, IN NO EVENT, SHALL DANIEL BE LIABLE FOR ANY INCIDENTAL, PUNITIVE, SPECIAL OR CONSEQUENTIAL DAMAGES INCLUDING, BUT NOT LIMITED TO, LOSS OF PRODUCTION, LOSS OF PROFITS, LOSS OF REVENUE OR USE AND COSTS INCURRED INCLUDING WITHOUT LIMITATION FOR CAPITAL, FUEL AND POWER, AND CLAIMS OF THIRD PARTIES.

PRODUCT NAMES USED HEREIN ARE FOR MANUFACTURER OR SUPPLIER IDENTIFICATION ONLY AND MAY BE TRADEMARKS/REGISTERED TRADEMARKS OF THESE COMPANIES.

DANIEL AND THE DANIEL LOGO ARE REGISTERED TRADEMARKS OF DANIEL INDUSTRIES, INC. THE EMERSON LOGO IS A TRADEMARK AND SERVICE MARK OF EMERSON ELECTRIC CO.

**COPYRIGHT © 2014
BY DANIEL MEASUREMENT AND CONTROL, INC.
HOUSTON, TEXAS, U.S.A.**

All rights reserved. No part of this work may be reproduced or copied in any form or by any means - graphic, electronic or mechanical - without first receiving the written permission of Daniel Measurement and Control, Inc., Houston, Texas, U.S.A.

1. **LIMITED WARRANTY:** Subject to the limitations contained in Section 2 herein, Daniel Measurement & Control, Inc. (“Daniel”) warrants that the licensed firmware embodied in the Goods will execute the programming instructions provided by Daniel, and that the Goods manufactured by Daniel will be free from defects in materials or workmanship under normal use and care and Services will be performed by trained personnel using proper equipment and instrumentation for the particular Service provided. The foregoing warranties will apply until the expiration of the applicable warranty period. Goods are warranted for twelve (12) months from the date of initial installation or eighteen (18) months from the date of shipment by Daniel, whichever period expires first. Consumables and Services are warranted for a period of 90 days from the date of shipment or completion of the Services. Products purchased by Daniel from a third party for resale to Buyer (“Resale Products”) shall carry only the warranty extended by the original manufacturer. Buyer agrees that Daniel has no liability for Resale Products beyond making a reasonable commercial effort to arrange for procurement and shipping of the Resale Products. If Buyer discovers any warranty defects and notifies Daniel thereof in writing during the applicable warranty period, Daniel shall, at its option, correct any errors that are found by Daniel in the firmware or Services or repair or replace F.O.B. point of manufacture that portion of the Goods or firmware found by Daniel to be defective, or refund the purchase price of the defective portion of the Goods/Services. All replacements or repairs necessitated by inadequate maintenance, normal wear and usage, unsuitable power sources or environmental conditions, accident, misuse, improper installation, modification, repair, use of unauthorized replacement parts, storage or handling, or any other cause not the fault of Daniel are not covered by this limited warranty, and shall be at Buyer’s expense. Daniel shall not be obligated to pay any costs or charges incurred by Buyer or any other party except as may be agreed upon in writing in advance by Daniel. All costs of dismantling, reinstallation and freight and the time and expenses of Daniel’s personnel and representatives for site travel and diagnosis under this warranty clause shall be borne by Buyer unless accepted in writing by Daniel. Goods repaired and parts replaced by Daniel during the warranty period shall be in warranty for the remainder of the original warranty period or ninety (90) days, whichever is longer. This limited warranty is the only warranty made by Daniel and can be amended only in a writing signed by Daniel. **THE WARRANTIES AND REMEDIES SET FORTH ABOVE ARE EXCLUSIVE. THERE ARE NO REPRESENTATIONS OR WARRANTIES OF ANY KIND, EXPRESS OR IMPLIED, AS TO MERCHANTABILITY, FITNESS FOR PARTICULAR PURPOSE OR ANY OTHER MATTER WITH RESPECT TO ANY OF THE GOODS OR SERVICES. Buyer acknowledges and agrees that corrosion or erosion of materials is not covered by this warranty.**

2. **LIMITATION OF REMEDY AND LIABILITY:** DANIEL SHALL NOT BE LIABLE FOR DAMAGES CAUSED BY DELAY IN PERFORMANCE. THE REMEDIES OF BUYER SET FORTH IN THIS AGREEMENT ARE EXCLUSIVE. IN NO EVENT, REGARDLESS OF THE FORM OF THE CLAIM OR CAUSE OF ACTION (WHETHER BASED IN CONTRACT, INFRINGEMENT, NEGLIGENCE, STRICT LIABILITY, OTHER TORT OR OTHERWISE), SHALL DANIEL’S LIABILITY TO BUYER AND/OR ITS CUSTOMERS EXCEED THE PRICE TO BUYER OF THE SPECIFIC GOODS MANUFACTURED OR SERVICES PROVIDED BY DANIEL GIVING RISE TO THE CLAIM OR CAUSE OF ACTION. BUYER AGREES THAT IN NO EVENT SHALL DANIEL’S LIABILITY TO BUYER AND/OR ITS CUSTOMERS EXTEND TO INCLUDE INCIDENTAL, CONSEQUENTIAL OR PUNITIVE DAMAGES. THE TERM “CONSEQUENTIAL DAMAGES” SHALL INCLUDE, BUT NOT BE LIMITED TO, LOSS OF ANTICIPATED PROFITS, REVENUE OR USE AND COSTS INCURRED INCLUDING WITHOUT LIMITATION FOR CAPITAL, FUEL AND POWER, AND CLAIMS OF BUYER’S CUSTOMERS.

TABLE OF CONTENTS

1.0 INTRODUCTION

 1.1 Principle of Operation. [1-1](#)

2.0 INSTALLATION. [2-1](#)

 2.1 Preliminary Steps. [2-1](#)

 2.2 Junior® Orifice Fitting Installation. [2-2](#)

 2.3 Fitting Leak Test. [2-4](#)

3.0 MAINTENANCE. [3-1](#)

 3.1 Normal Conditions. [3-1](#)

4.0 OPERATING INSTRUCTIONS. [4-1](#)

 4.1 Plate Removal. [4-2](#)

 4.2 Plate Insertion. [4-3](#)

5.0 SUPPLEMENTAL INFORMATION. [5-1](#)

This page intentionally left blank.

1.0 INTRODUCTION

1.1 Principle of Operation

The Daniel Junior® Orifice Fitting is a device that houses, and accurately positions, a Daniel orifice plate for measuring flow within a pipe or tube. When placed in the Daniel Junior® Orifice Fitting, an orifice plate will produce a differential pressure by abruptly constricting the medium flowing through it. The differential pressure is measured across the plate through two taps located on the Daniel Junior® Orifice Fitting in the vicinity of the constriction.

The Daniel Junior® Orifice Fitting's single-chamber design allows for the inspection and the replacement of orifice plates without removing the fitting from the flow line. Use of the Daniel Junior® Orifice Fitting eliminates the effort required to remove and inspect an orifice plate housed in conventional orifice flange installations.

Daniel manufactures all Junior® units to meet or exceed A.G.A. 2000 recommendations, and are in accordance with ANSI flange connection specifications and ASTM specifications.

Products bearing the “CE” mark are manufactured in compliance with the European Union Pressure Equipment Directive (PED) 97/23/EC.

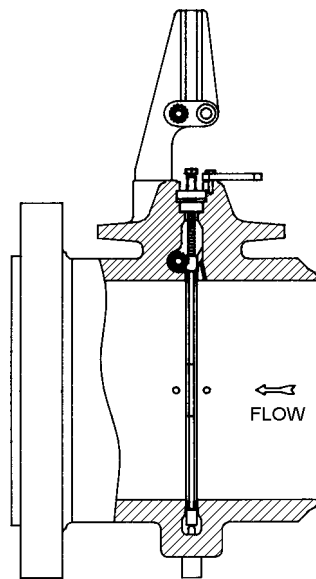
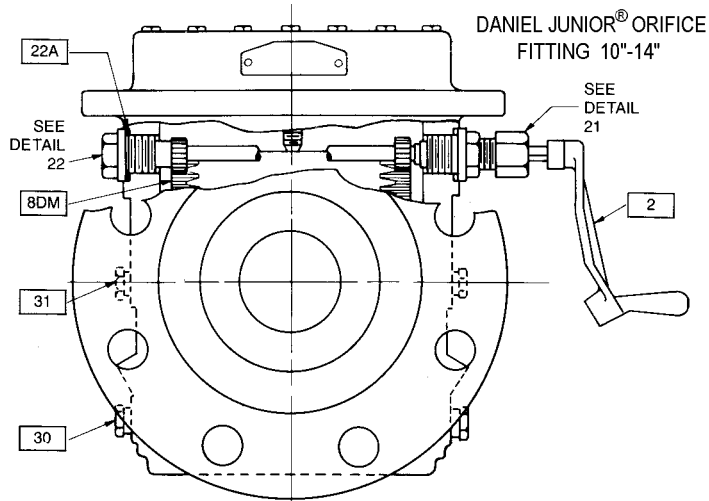
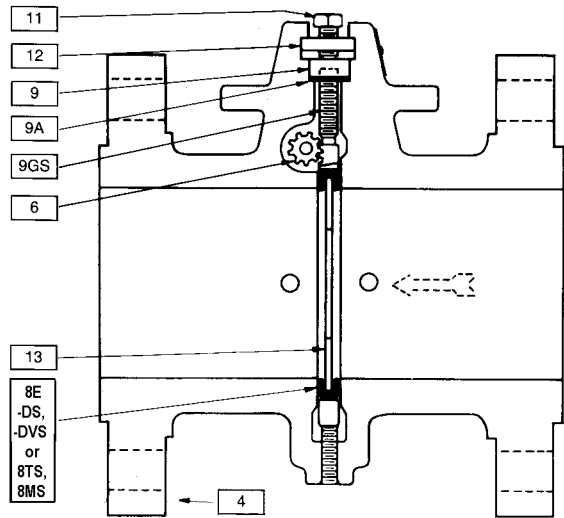

Figure 1-1. Cross-Sectional View of Orifice Plate in the Operating Position
Within the Daniel Junior Orifice Fitting



FRONT SECTIONAL ELEVATION



SIDE SECTIONAL ELEVATION

STUFFING BOX FOR 10" - 24" FITTING (EXCEPT 2500 CLASS)

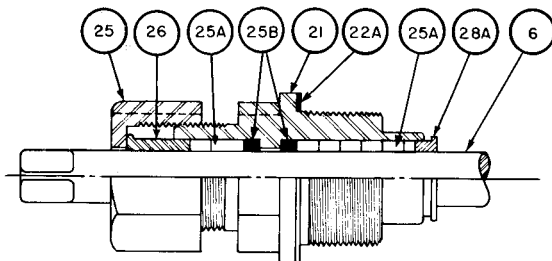

DETAIL 21-0

BEARING PLUG (EXCEPT 2500 CLASS)

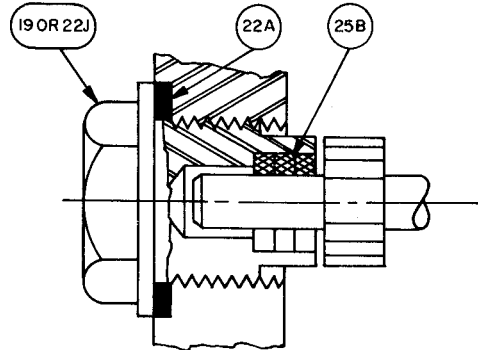

DETAIL 22

STUFFING BOX FOR 10" - 12" FITTING (CLASS 2500 ONLY)

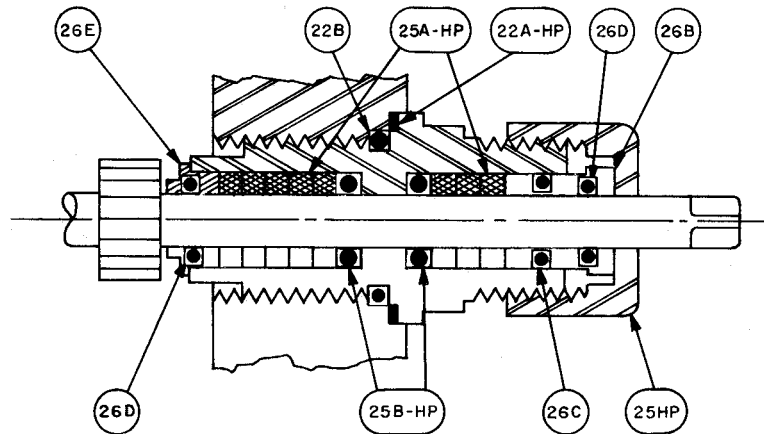

DETAIL 21 HP

BEARING PLUG (CLASS 2500 ONLY)

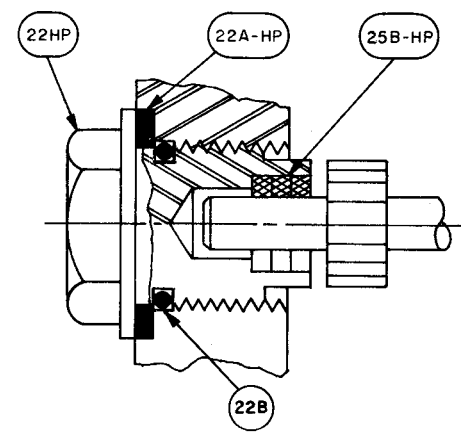

DETAIL 22 HP

DANIEL JUNIOR® ORIFICE FITTING 16"-42"

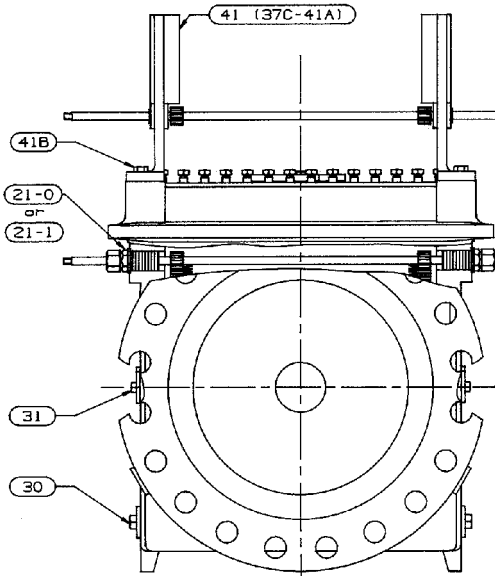

FRONT SECTIONAL ELEVATION

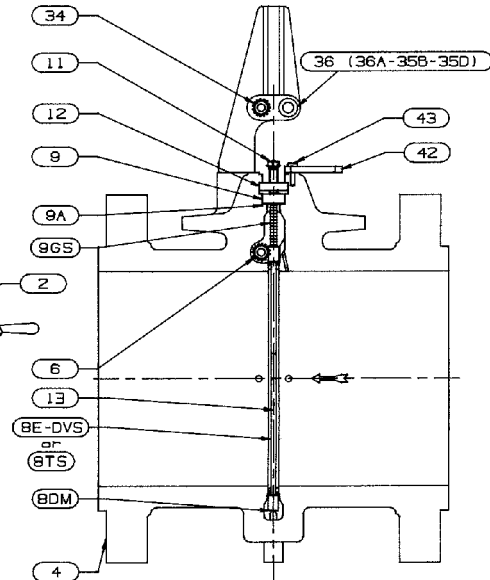

SIDE SECTIONAL ELEVATION

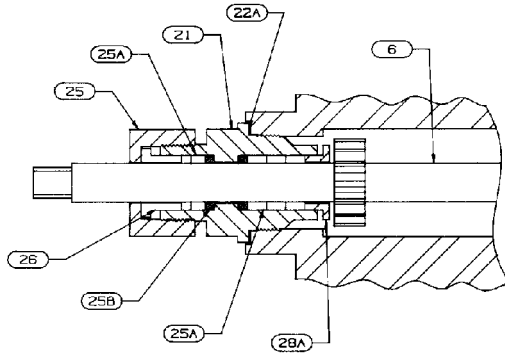

DETAIL 21-0 (STUFFING BOX FOR 16"-24" FITTING)

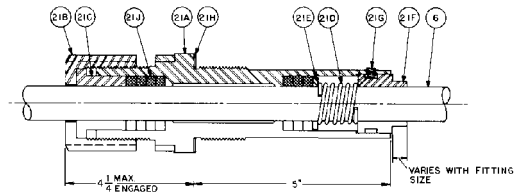

DETAIL 21-1 (STUFFING BOX FOR 30"-42" FITTING)

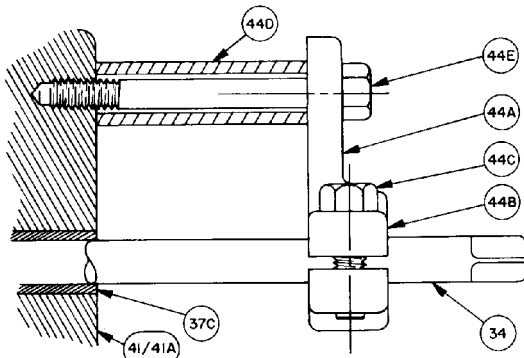

DETAIL 44 (42" ONLY)

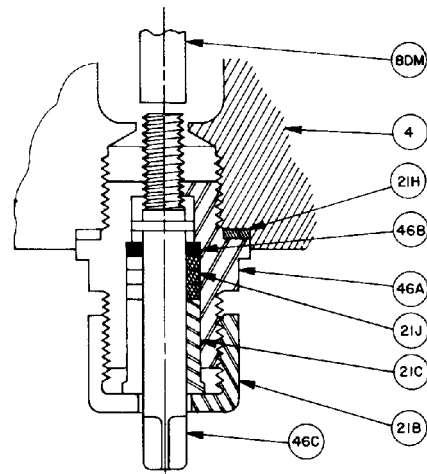

DETAIL 46 (42" ONLY)

1.2 Parts and Materials List

PART NO.	DESCRIPTION	MATERIAL AND RATINGS	NUMBER REQUIRED (SIZES IN INCHES)													
			10	12	14	16	18	20	24	30	34	36	42			
2	Operating Wrench	Malleable Iron	1	1	1	1	1	1	1	1	1	1	1	1	1	4
4	Body	Cast Iron Steel	1	1	1	1	1	1	1	1	1	1	1	1	1	1
6	Plate Carrier Shaft and Pinions	C.R.S. (Chemically Treated) 30"- 42" (316SS)	1	1	1	1	1	1	1	1	1	1	1	1	1	1
8 DM	Plate Carrier	C.R.S. (Chemically Treated)	1	1	1	1	1	1	1	1	1	1	1	1	1	1
8 E-DS	Sealing Unit	Synthetic Rubber (Removable)	1													
8 E-DVS	Sealing Unit	Synthetic Rubber Bonded to Both Sides Orifice Plate		1	1	1	1	1	1	1	1	1	1	1	1	1
8 TS	Optional Sealing Units for Special Services	Teflon (Plate Not Included)*	1	1	1	1										
8 MS	Optional Sealing Units for Special Services	Cadmium Plated and Stainless Steel (Plate Not Included)*	1	1	1											
	Integral Metal Seal*	Stainless Steel										1	1	1	1	1
9	Sealing Bar	C.R.S. (Chemically Treated)	1	1	1	1	1	1	1	1	1	1	1	1	1	1
9 HP*	Sealing Bar	C.R.S. (Chemically Treated) (1500 Only)*	1	1												
		(2500 Only)*	1	1												
9 GS	Sealing Bar Alignment Pin	C.R.S. (Chemically Treated)	1	1	1	1	1	1	1	1	1	1	1	1	1	1
9 A	Sealing Bar Gasket	Composite	1	1	1	1	1	1	1	1	1	1	1	1	1	1
11	Clamping Bar Screws	Steel (150-600)	8	10	11	12	14	15	18	24	34	24	32			
		Steel (900)	8	10	22	24	28	28	36							
		Steel (1500 Only)	16	20	22	22	28	28								
		Steel (2500 Only)	28	28												
12	Clamping Bar	C.R.S. (Chemically Treated) (150-900)	1	1	1	1	1	1	1	1	1	1	1	1	1	1
12 HP*	Clamping Bar	C.R.S. (Chemically Treated) (1500)	1	1												
		(2500)	1	1												
13	Orifice Plate	Stainless Steel	1	1	1	1	1	1	1	1	1	1	1	1	1	1
14*	Top	Cast Iron Steel									1	1			1	
16 A*	Plate Carrier Guide Screw	316 Stainless Steel									4	4			4	
18 A*	Body-Top Gasket	Composite									1	1			1	
18 C*	Plate Carrier Guide	Carbon Steel									2	2			2	
21-0 & 21-1	Stuffing Body Assembly		1	1	1	2	2	2	2	2	2	2	2	2		
21 & 21 A	Stuffing Body Box	C.R.S.	1	1	1	2	2	2	2	2	2	2	2	2	2	2
21E	Packing Retainer Washer	316 Stainless Steel									2	2	2	2	2	2

PART NO.	DESCRIPTION	MATERIAL AND RATINGS	NUMBER REQUIRED (SIZES IN INCHES)															
			10	12	14	16	18	20	24	30	34	36	42					
22 & 22 HP	Bearing Plug	C.R.S.	1	1	1													
22 A & 22 A-HP & 21 H	Bearing Plug and Stuffing Box Gaskets	Stainless Steel	2	2	2	2	2	2	2	2	2	2	2	2	2	2	2	2
22 B	Bearing Plug and Stuffing Box "O" Ring Seals	Synthetic Rubber (Daniel 2500 Only)	2	2														
22 J	Special Stuffing Box Body Plug	Carbon Steel											2	2				2
25 & 25 HP & 21B	Packing Nuts	C.R.S. (Chemically Treated)	1	1	1	2	2	2	2	2	2	2	2	2	2	2	2	2
25 A & 21 J	Packing Sleeves	Teflon Daniel 150	9	11	12	14	14	14	14	14	16	16	16	16				
		Teflon Daniel 300	9	11	12	14	16	14	14	14	16	16	16	16				
		Teflon Daniel 600	10	11	13	14	16	20	22	16	16	16						
		Teflon Daniel 900	10	11														
		Teflon Daniel 1500	12	14														
25 A-HP	Packing Sleeves	Teflon Daniel 2500	10	10														
25 B & 25 B-HP	Shaft Centering Rings	Teflon (None in 30" - 42")	2 Per Stuffing Box, 3 Per Bearing Plug															
26 & 21 C	Stuffing Box Glands	Stainless Steel (150 -1500)	1	1	1	2	2	2	2	2	2	2	2	2	2	2	2	2
26 B	External Stuffing Box Glands with "O" Ring Groove	316 Stainless Steel (2500 Only)	1	1														
26 E	Internal Stuffing Box Glands with "O" Ring Groove	316 Stainless Steel (2500 Only)	1	1														
26 C	"O" Rings	Synthetic Rubber (2500 Only)	1	1														
26 D	"O" Rings	Synthetic Rubber (2500 Only)	2	2														
28 A & 21 F	Packing Bushing & Retainer	Stainless Steel (10" - 24") (150 -1500)	2	2	2	2	2	2	2									2
		Bronze (30" - 42")												2	2	2		
21 D	Stuffing Box Spring	316 Stainless Steel											2	2	2	2		
21 G	Busing Set Screws	316 Stainless Steel											2	2	2	2		
30	Drain Valve Plug	C.R.S.	2	2	2	2	2	2	2	2	2	2	2	2	2	2	2	2
31	1/2" N.P.T. Tap Hole Plug	C.R.S.	4	4	4	4	4	4	4	4	4	4	4	4	4	4	4	4
32*	Heavy Hex Nut	Steel (150)											40					
		Steel (600)												48		54		
33*	Studs	Steel (150)											40					
		Steel (600)												48		54		
34	External Plate Carrier Shaft and Pinions	C.R.S. (Chemically Treated) 30" - 42" (316SS)					1	1	1	1	1	1	1	1	1	1	1	1
36 & 36 A	External Shaft and Roller Assembly Shaft	C.R.S. (Chemically Treated) 30" - 42" (316SS)					1	1	1	1	1	1	1	1	1	1	1	1

PART NO.	DESCRIPTION	MATERIAL AND RATINGS	NUMBER REQUIRED (SIZES IN INCHES)											
			10	12	14	16	18	20	24	30	34	36	42	
35 B	Rollers	Bronze					2	2	2	2	2	2	2	2
35 D	Roller Snap Rings	Steel (Chemically Treated)					2	2	2	2	2	2	2	4
41 & 41 A	Plate Carrier Guide Bracket Assembly: Brackets	Cast Carbon Steel					2	2	2	2	2	2	2	2
41 B	Hex Head Cap Screws	Steel					4	4	4	4	4	4	4	4
37 C	Shaft Bushing	Bronze					4	4	4	4	4	4	4	4
42	Plate Carrier Stop	Steel					1	1	1	1	1	1	1	1
43	Socket Head Cap Screw w/Bushing	Steel					1	1	1	1	1	1	1	1
44 & 44 A	Plate Carrier Travel Brake: Body	Cast Steel												4
44 B	Brake Band	Bronze												4
44 C	Adjustment Bolt	Steel												4
44 D	Sleeve	Steel												4
44 E	Hex Bolt	Steel												4
45 A	Shaft Support	Steel												2
45 B	Shaft Support Bushing	Bronze												4
45 C	Supporting Mtg. Bolts	Steel												4
46 & 46 A	Jackscrew Assembly: Jackscrew Body	316 Stainless Steel												1
46 C	Jackscrew Stem	4140												1
46 B	Jackscrew Ctrg. Ring	316 Stainless Steel												1

* Indicates parts interchangeable
C.R.S. - cold rolled steel

2.0 INSTALLATION

2.1 Preliminary Steps

On installations which are required to comply with the European Union Pressure Equipment Directive (PED) 97/23/EC, it is the responsibility of the end user to ensure that all Essential Safety Requirements of this directive are met.

Before installing the fitting into the line, clean piping of all foreign material such as welding chips, scale, oil, grease, and dirt.

Remove all foreign matter such as scale, oil, grease, and dirt from the fitting line connections and internal cavities of the fitting that may have collected during the time of final factory inspection and line installation.

If the end user expects the Daniel Junior® Orifice Fitting to encounter severe conditions (conditions where there is likely to be an accumulation of sediment from any cause), installation personnel should install a blow down valve in place of the pipe plug (30) at the bottom of the fitting (See Section 3.0, Maintenance section for instructions concerning severe service conditions).

Record the fitting's plate data for future reference. Always provide the serial number and model number of the fitting when ordering spare parts.

It is the responsibility of the end user to install the fitting in a well designed piping system taking due regard of the following.

1. Internal/external pressure
2. Ambient and operational temperatures
3. Static pressure and mass of contents in operating and test conditions
4. Traffic, wind and earth loading
5. Piping loads which result from supports and attachments
6. Corrosion, erosion, fatigue, etc.
7. Decomposition of unstable fluids
8. Possible damage from external fire

2.2 Junior® Orifice Fitting Installation



SERIOUS PERSONAL INJURY OR DEATH

The Daniel Junior® Orifice Fitting is a device that contains fluid at elevated pressure.

Failure to follow the instructions in this manual can result in serious injury or death.

1. The Daniel Junior® Orifice Fitting is only one component of an orifice metering system. If the Junior® Orifice Fitting is received without a meter tube, consult the appropriate Codes for construction details.
2. When designing your orifice metering system, allow sufficient space around the Daniel Junior® Orifice Fitting. Clearance for both fitting wrench operation and plate changing must be verified. Check accessibility of all meter pressure taps (3) and drain taps (30) prior to installation.
3. Before installing the meter tube containing the Junior® Orifice Fitting, clean the meter tube interior as well as the piping sections where the fitting meter tube will be installed. Remove all foreign materials such as welding debris, scale, oil, grease or dirt.
4. If end flanges are used, select and install the proper gaskets and tighten all bolting to insure gasket seating and tightness. If welded connections are used, use proper procedures for the materials being joined.
5. After the meter tube is in place and all connections are made, the meter tube containing the Junior® Orifice Fitting should be pressure tested.
6. Tighten fitting clamping bar screws (11) securely to the torque values provided in Section 5.2 of this manual.
7. Pressure test the line containing the meter tube with Junior® Orifice Fitting using an appropriate test procedure. NOTE: No orifice plate should be in the fitting during testing.
8. Check the entire assembly for leaks.



SERIOUS PERSONAL INJURY OR DEATH

The correct positioning and installation of the sealing bar gasket (9A), sealing bar (9, 9HP), and clamping bar (12, 12HP) are essential to provide a pressure barrier between the line pressure and atmospheric pressure.

Failure to install the sealing bar gasket (9A), sealing bar (9, 9HP), and clamping bar (12, 12HP) can result in serious injury or death.

2.3 Fitting Leak Test



SERIOUS PERSONAL INJURY OR DEATH

The Daniel Junior® Orifice Fitting is a device that contains fluid at elevated pressure.

Failure to follow the instructions in this manual can result in serious injury or death.

Once personnel install the orifice metering system Daniel Junior® Orifice Fitting, and secure the clamping bar (12, 12HP), a leak test must be performed as follows:

1. Install a pressure gauge calibrated to a recognized standard, on the line system in a location where the gauge will detect the pressure inside the Daniel Junior® Orifice Fitting. The calibrated gauge must be rated to operate at least 150% above the maximum operating pressure of the system (the Daniel Junior® Orifice Fitting and the adjacent piping).
2. Slowly pressurize the Daniel Junior® Orifice Fitting at a rate of 1 psig per second (0.15 bars per second) until the pressure inside the fitting reaches 20 psig (1.4 bar), then stop and hold that pressure for five minutes. During the five-minute hold, apply a leak detection solution to all joint and connector areas of the fitting and line connections. No leakage should be visibly or audibly detectable during the hold period.
3. If a leak is detected, identify the leak area and reduce the pressure inside the Daniel Junior® Orifice Fitting to 0 psig (0 bar). Tighten any fastener or connector adjacent to the leak area and repeat the leak test again.
4. If several attempts to stop the leak fail, call Daniel for assistance.

**SERIOUS PERSONAL INJURY OR DEATH**

Correct all leaks prior to operation.

Failure to stop any size leak may lead to serious injury or death.

5. Once the 20 psig (1.4 bar) leak test is complete, and no leaks are detected, slowly raise the pressure inside the Daniel Junior® Orifice Fitting at a rate of 10 psig per second to the maximum operating pressure of the system (the Daniel Junior® Orifice Fitting and the adjacent piping) or the line operating pressure. Hold the maximum operating pressure inside the fitting for a period of 10 minutes.

On installations which are required to comply with the European Union Pressure Equipment Directive (PED) 97/23/EC, the installation must be tested to at least 1.43 times the MAOP of the lowest rated component in the system.

6. During the ten-minute hold period, apply a leak detection solution to all joint and connector areas of the fitting and line connections. No leakage should be visibly or audibly detectable during the hold period.

If a leak is detected, identify the leak area and reduce the pressure inside the fitting to 0 psig (0 bar). Tighten any fastener or connector adjacent to leak area and repeat the leak test again. If several attempts to stop the leak fail, call Daniel for assistance.

7. Slowly release the pressure from the fitting until the gauge reads zero (0) psig.
8. If there are no leaks, the Daniel Junior® Orifice Fitting is now ready for orifice plate installation, final pressurization and operation.

This page intentionally left blank.

3.0 MAINTENANCE



SERIOUS PERSONAL INJURY OR DEATH

The Daniel Junior® Orifice Fitting is a device that contains fluid at elevated pressure.

Failure to follow the instructions in this manual can result in serious injury or death.

3.1 Normal Conditions

Maintenance personnel should inspect the Daniel Junior® Orifice Fitting periodically at an interval established by the measurement supervisor. The inspection is to include a visual assessment of the fitting for vandalism, or other inadvertent damage and well as fastener and connector components for tightness.

It is the responsibility of the end user to make periodic inspections at such intervals as deemed appropriate during the life of the system to ensure that the corrosion/erosion tolerance dimensions of the fitting have not been exceeded.

3.2 Severe Conditions

Follow the steps described above along with the following:

Under severe conditions where there is likely to be an accumulation of sediment from any cause, installation personnel should install blow down valves in place of the drain valve plugs (30) at the bottom of the fitting.

This page intentionally left blank.

4.0 OPERATING INSTRUCTIONS

The Daniel Junior® Orifice Fitting design allows an operator to install or remove the orifice plate (13) with a minimum amount of line shut down time.

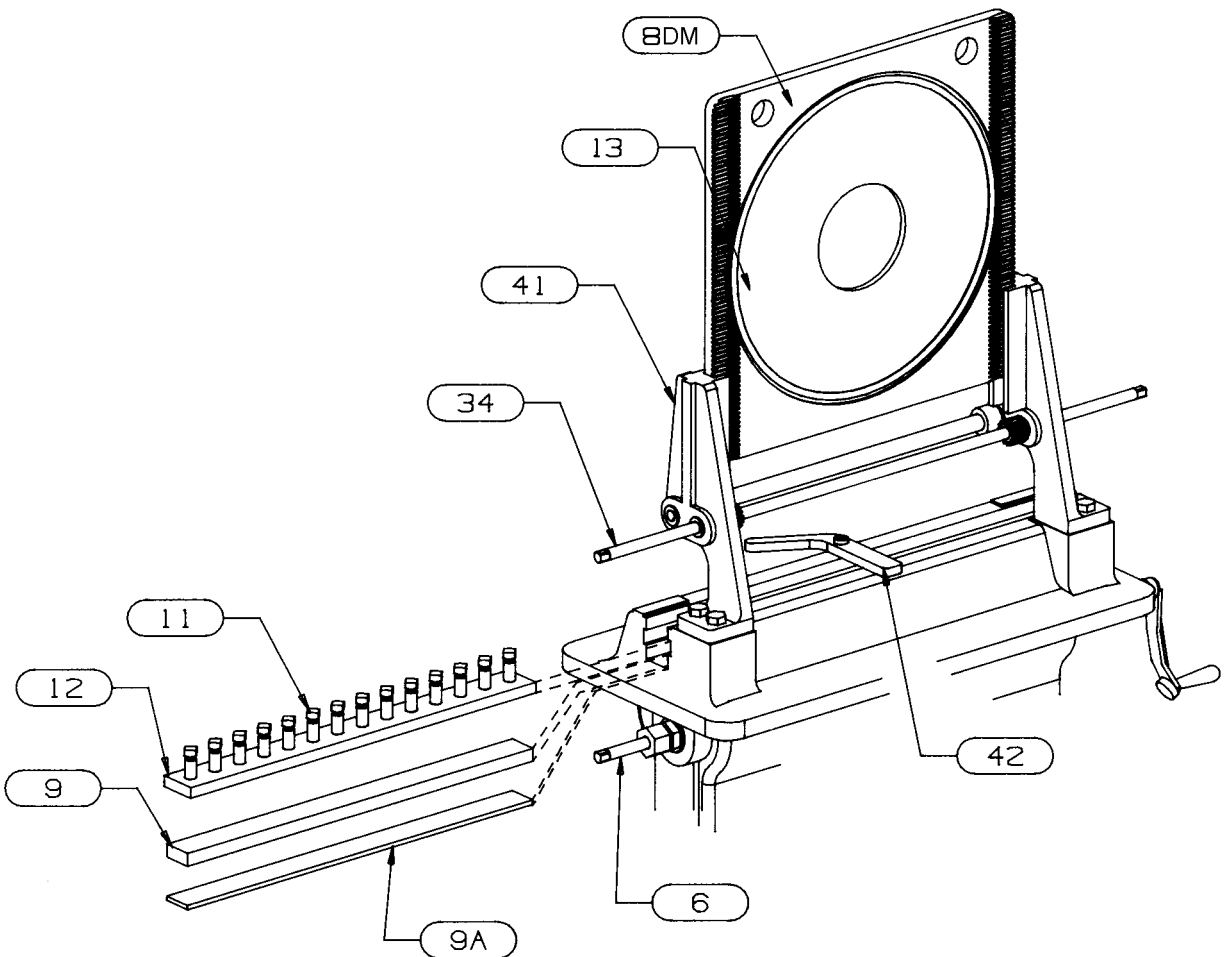

Figure 4-1. Components Involved in Plate Removal and Insertion Process

4.1 Plate Removal

Conditions:

- Isolate and *gradually* depressurize the line containing the Daniel Junior® Orifice Fitting.
- The orifice plate (13) located in flow stream and in the Daniel Junior® Orifice Fitting.

Procedure:

1. Depressurize or shut in the line supporting the Daniel Junior® Orifice Fitting.



SERIOUS PERSONAL INJURY OR DEATH

The Daniel Junior® Orifice Fitting is a device that contains fluid at elevated pressure.

Failure to follow the instructions in this manual can result in serious injury or death.

2. Once pressure in the fitting is reduced to ambient pressure, the operator may then extract the sealing bar (9, 9HP) and orifice plate carrier (8DM).
3. Loosen the clamping bar screws (11) on the clamping bar (12, 12HP) two turns.
4. Lightly tap the sealing bar (9, 9HP) to break the gasket (9A) seal.

5. Slide out the clamping bar (12, 12HP).
6. Lift out the sealing bar (9, 9HP) and the sealing bar gasket (9A).
7. Rotate the plate carrier shaft (6) to raise the plate carrier (8DM).
8. For Daniel Junior® Orifice Fittings sizes 10" through 16" remove the orifice plate carrier (8DM) from the fitting.

For Daniel Junior® Orifice Fittings sizes larger than 16", rotate the external plate carrier shaft (34) to position the plate carrier (8DM) in the plate carrier guide-bracket assembly (41), and position the plate carrier stop (42) under the plate carrier to hold it in place to allow inspection, cleaning or plate changing.

9. Remove the orifice plate sealing unit (8E-DS, 8TS, 8MS) from the orifice plate (13). For orifice plates with sealing unit part number 8E-DVS, the synthetic rubber is permanently bonded to the plate and cannot be separated.

4.2 Plate Insertion



SERIOUS PERSONAL INJURY OR DEATH

The Daniel Junior® Orifice Fitting is a device that contains fluid at elevated pressure.

Failure to follow the instructions in this manual can result in serious injury or death.

Conditions:

- Daniel Junior® Orifice Fitting in line, and the sealing bar (9, 9HP) and clamping bar (12, 12HP) removed from the body (4).

Procedure:

1. Install a new sealing bar gasket (9A) onto the Daniel Junior® Orifice Fitting body (4).
2. Install a new orifice seal (8E-DS, 8TS, 8MS) on the orifice plate (13), except where sealing unit part number 8-DVS (permanently bonded synthetic rubber) is in use.
3. Install the orifice plate (13) and seal assembly (8E-DS, 8TS, 8MS) as required into the plate carrier (8DM) taking into account the flow direction of the line (inlet side upstream).

CAUTION

Failure to install the orifice plate (13) and the seal assembly (8E-DS, 8TS, 8MS) in a direction properly oriented with the direction of flow will result in measurement error and a possible loss of revenue.

4. For Daniel Junior® Orifice Fittings sizes 10" through 16", rotate the plate carrier shaft (6) to seat the plate carrier (8DM) in the fitting.

For Daniel Junior® Orifice Fittings larger than 16", rotate the external plate carrier shaft (34) to raise the plate carrier (8DM), and position the plate carrier stop (42) clear of the opening. Rotate the external plate carrier shaft (34) to lower the plate carrier (8DM) into the top of the fitting body (4), and engage the gears associated with the plate carrier shaft (6). Rotate the plate carrier shaft (6) to seat the plate carrier (8DM) in the fitting.
5. Install the sealing bar gasket (9A) and the sealing bar (9, 9HP).
6. Install the clamping bar (12, 12HP).
7. Tighten each of the clamping bar screws (11) to the torque recommended in Section 5.2 of this manual.
8. The Junior® Orifice Fitting is now ready for final pressurization and operation.

5.0 SUPPLEMENTAL INFORMATION**5.1 Recommended Spare Parts for One-Year Operation**

DESCRIPTION	QUANTITY	PART NO.
Plate Carrier Shaft and Pinions	1	6
Orifice Plate Sealing Unit	3	8E-DS, 8TS or 8MS
Sealing Bar Gasket	5	9A
Clamping Bar Screws	2	11
Stuffing Box/Bearing Plug Gasket	2	22A
Packing Sleeves	1 set	25A
Shaft Centering Rings	1 set	25B

5.2 Clamping Bar Screw Torque Table

JUNIOR CLAMPING BAR SCREW TORQUE FT-LBS (See Figure 5-1)

SIZE	RATING	NO. OF SCREWS	SCREW SIZE	TORQUE Min	TORQUE Max
10"	150	8	1/2"-13	75	95
	300	8	1/2"-13	75	95
	600	8	1/2"-13	75	95
	900	8	5/8"-11	145	180
	1500	20	5/8"-11	145	180
	2500	26	5/8"-11	145	180
12"	150	10	1/2"-13	75	95
	300	10	1/2"-13	95	120
	600	10	1/2"-13	95	120
	900	10	5/8"-11	120	150
	1500	20	5/8"-11	145	180
	2500	28	5/8"-11	145	180
14"	150	11	1/2"-13	75	95
	300	11	1/2"-13	75	95
	600	11	1/2"-13	95	120
	900	22	5/8"-11	145	180
	1500	22	5/8"-11	155	195
16"	150	12	1/2"-13	75	95
	300	12	1/2"-13	75	95
	600	12	5/8"-11	145	180
	900	28	5/8"-11	145	180
	1500	28	5/8"-11	155	195
18"	150	14	5/8"-11	145	180
	300	14	5/8"-11	145	180
	600	28	5/8"-11	160	200
	900	28	5/8"-11	170	215
	1500	28	5/8"-11	170	215
20"	150	15	5/8"-11	145	180
	300	15	5/8"-11	145	180
	600	15	5/8"-11	200	250
	900	30	5/8"-11	170	215
	1500	28	5/8"-11	200	250
24"	150	18	5/8"-11	145	180
	300	18	5/8"-11	145	180
	600	20	5/8"-11	180	225
	900	40	5/8"-11	180	225
	1500	40	5/8"-11	180	225

SIZE	RATING	NO. OF SCREWS	SCREW SIZE	TORQUE Min	TORQUE Max
28" & 30"	150	24	5/8"-11	145	180
	300	24	5/8"-11	200	250
	600	24	5/8"-11	200	250
34"	150	34	5/8"-11	200	250
	300	34	5/8"-11	200	250
	600	34	5/8"-11	200	250
36"	150	24	5/8"-11	145	180
	300	24	5/8"-11	170	215
	600	24	5/8"-11	170	215
40" & 42"	150	32	5/8"-11	170	215
	300	32	5/8"-11	200	250
	600	32	5/8"-11	200	250

Figure 5-1. Typical Bolt Torquing Sequence for an 8-Bolt, Single Row and a 16-Bolt, Double Row Clamping Bar

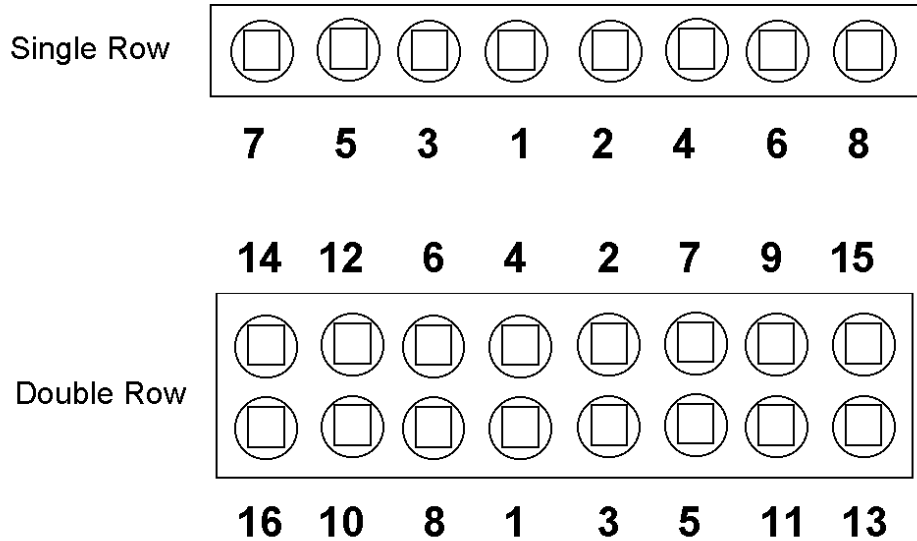

This page intentionally left blank.

NOTES

NOTES

DANIEL MEASUREMENT AND CONTROL, INC.

RETURN POLICY FOR WARRANTY AND NON-WARRANTY MATERIAL

Use the following procedure for returning equipment to the Daniel factory in the United States.

Step 1 Obtaining a RMA Number

A Return Material Authorization (RMA) number must be obtained prior to returning any equipment for any reason.

To obtain a RMA number, call the Customer Service Department at 713-827-5033 between 8:00 a.m. and 5:00 p.m. (Central Standard Time), Monday through Friday, except holidays or email daniel.support@emersonprocess.com.

NOTICE

No product returns will be accepted without a RMA number and will be returned at the customer's expense.

For warranty consideration, the product must be returned to Daniel within twelve (12) months of the date of original shipment or within eighteen (18) months of the date of original shipment of the product to destinations outside the United States. The Purchaser must prepay any shipping charges.

In addition, the Purchaser is responsible for insuring any product shipped for return, and assumes the risk of loss of the product during shipment.

- The following information is required at the time the RMA is issued:
 - Customer name
 - Contact name
 - Billing address
 - Contact Phone # and email address
 - Daniel SO #, PO #, or Invoice #
 - Item(s) to be returned
 - Reason for return
 - End user and final destination address
 - Consignee's complete name, address, contact name and phone number
- A RMA number is required for each original order. (Example: Two fittings purchased on two separate orders now being returned require two RMA numbers.)

For product returns from locations outside the United States, Daniel Customer Service personnel will provide additional shipping requirements.

Step 2 Cleaning and Decontamination

Prior to shipment, thoroughly clean and decontaminate all equipment removing all foreign substances. This includes all substances used for cleaning the equipment. The cleaning and decontamination requirement applies to any part exposed to process fluids or cleaning substances.

Shipping equipment that has not been decontaminated may be in violation of U.S. Department of Transportation (DOT) regulations. For your reference, the requirements for packaging and labeling hazardous substances are listed in DOT regulations 49 CFR 172, 178, and 179.

If you suspect that a part has been contaminated, the part must be completely drained and flushed to remove contaminants.



MAY CAUSE DEATH OR SERIOUS INJURY TO PERSONNEL

Contents may be under pressure or materials may be hazardous

Improper handling of pressurized equipment could lead to contact with hazardous materials or contaminated units and parts. Death or serious injury could result. Always follow appropriate handling instructions for accessing pressurized equipment.

Decontamination/Cleaning Statement

A blank Decontamination/Cleaning Statement is provided on the “Returned Material Authorization Repair Form for Used Equipment”.

- A Decontamination/Cleaning Statement is required for each returned part.
- Fully complete each form and include a signature. If the decontamination statement is incomplete, the customer may be charged for decontamination and cleaning.

If the equipment has been exposed to a known hazardous substance with any characteristic that can be identified in the Code of Federal Regulations, 40 CFR 261.20 through 261.24, the chemical abstracts number and hazardous waste number/hazard code must be stated in the space provided on the form.

Two (2) copies of each Decontamination/Cleaning Statement must be provided:

- One (1) copy must be attached to the outside of the package.
- One (1) copy must be included inside the package.

Step 3 Material Safety Data Sheets (MSDS)

Provide a Material Safety Data Sheet (MSDS) with the returned equipment for each substance that has come in contact with the equipment being returned, including substances used for decontamination and cleaning.

A MSDS sheet is required by law to be available to people exposed to specific hazardous substances, with one exception: if the equipment has only been exposed to food-grade substances or potable water, or other substances for which an MSDS is not applicable, the Decontamination/Cleaning Statement form alone is acceptable.

Two (2) copies of each MSDS must be provided:

- One (1) copy must be attached to the outside of the package.
- One (1) copy must be provided inside the package.

Step 4 Packaging

Shipping a Device With Possible Contamination

To meet DOT requirements for identifying hazardous substances, ship only one device per package.

Shipping a Device Without Any Potential Contamination

Devices being returned may be shipped together in one package, if there is no potential of foreign substance contamination.

Step 5 Shipping

Before returning used equipment:

- Mark each package clearly with a RMA number.
- Include a Decontamination/Cleaning Statement inside the package.
- Attach a duplicate Decontamination/Cleaning statement to the outside of the package.
- Include a MSDS for each substance that has come in contact with the equipment inside the package.
- Attach a duplicate MSDS to the outside of the package.

NOTICE

No product returns will be accepted without a RMA number and will be returned at the customer's expense.

For warranty consideration, the product must be returned to Daniel within twelve (12) months of the date of original shipment or within eighteen (18) months of the date of original shipment of the product to destinations outside the United States. The Purchaser must prepay any shipping charges.

Ship all * mechanical equipment to the following address:

Daniel Measurement and Control, Inc.
Attn: Service Dept.
5650 Brittmoore Rd.
Houston, TX 77041
Ref: RMA# _____

*Mechanical equipment includes: Orifice Fittings, Parts, Plates, Seal Rings, Turbine Meters, Control Valves, Provers, Strainers, Meter Tubes, Ultrasonic Meters, Flow Conditioners, etc.

Ship all * electronic equipment to the following address:

Daniel Measurement and Control, Inc.
Attn: Service Dept.
11100 Brittmoore Park Drive
Houston, TX 77041
Ref: RMA# _____

*Electronic equipment includes: Gas Chromatographs, Petrocount Presets, Danload Preset, Ultrasonic Meter Electronics (CPU boards, transducers, etc.), 2403 Totalizer, MRT 97 Indicator, Preamps, Pick Up Coils, Prover Interface Boards, and the following Flow Computer Models: 2230, 2239, 2270, 2460, 2470, S100, 2100, and 3000.

Daniel Measurement and Control, Inc.

Returned Material Authorization

Repair Form for Used Equipment Including Decontamination/Cleaning Statement

1. Return Material Authorization (RMA) Number _____
2. Equipment to be returned:
 Model Number _____ Serial Number _____
3. Reason for return: _____

Decontamination/Cleaning Fluids Process					
A. List each substance in which the equipment was exposed. Attach additional documents if necessary.					
Common Name	CAS# if available	Used for Hazardous Waste (20 CFR 261)		EPA Waste Code if used for hazardous waste	
		<input type="checkbox"/> Yes	<input type="checkbox"/> No		
		<input type="checkbox"/> Yes	<input type="checkbox"/> No		
		<input type="checkbox"/> Yes	<input type="checkbox"/> No		
		<input type="checkbox"/> Yes	<input type="checkbox"/> No		
		<input type="checkbox"/> Yes	<input type="checkbox"/> No		
		<input type="checkbox"/> Yes	<input type="checkbox"/> No		
B. Circle any hazards and/or process fluid types that apply:					
Infectious	Radioactive	Explosive	Pyrophoric	Poison Gas	
Cyanides	Sulfides	Corrosive	Oxidizer	Flammable	Poison
Carcinogen	Peroxide	Reactive-Air	Reactive-Water	Reactive-Other (list)	
Other hazard category (list):					
C. Describe decontamination/cleaning process. Include MSDS description for substances used in decontamination and cleaning processes. Attach additional documents if necessary.					

Shipping Requirements

Failure to comply with this procedure will result in the shipment being refused.

4. Write the RMA number on the shipping package.
5. Inside the package include one copy of this document and all required Material Safety Data Sheets (MSDS)
6. Outside of the package attach one copy of this document and all required Material Safety Data Sheets (MSDS).

THIS EQUIPMENT, BEING RETURNED "FOR REPAIR," HAS BEEN COMPLETELY DECONTAMINATED AND CLEANED. ALL FOREIGN SUBSTANCES HAVE BEEN DOCUMENTED ABOVE AND MSDS SHEETS ARE ATTACHED.

By:

(Signature)

(Print name)

Title:

Date:

Company:

Phone:

Fax:

The sales and service offices of Daniel Measurement and Control are located throughout the United States and in major countries overseas.
Please contact Daniel Measurement Services at 11100 Brittmoore Park Drive, Houston, Texas 77041, or phone (713) 827-6314 for the location of the sales or service office nearest you.
Daniel Measurement Services offers both on-call and contract maintenance service designed to provide single-source responsibility for all Daniel products.

Daniel Measurement and Control, Inc., and Daniel Measurement Services, Inc. Divisions of Emerson Process Management reserves the right to make changes to any of its products or services at any time without prior notification in order to improve that product or service and to supply the best product or service possible.
www.emersonprocess.com/daniel

DANIEL[®]

EMERSON[™]
Process Management