

# PD 600 DPI with RS-485 P-NET Interface

## PD Series 600



PD 600 DPI is used to provide local programmable intelligence and set as a gateway between the standard P-NET system (RS-485) and the local cluster via Light-Link P-NET. It uses the BM 002 base module. The PD 600 is included in the Series 600 modules and features:

- Real time clock with battery backup
- Up to 480 kB RAM memory with battery backup for user data
- Up to 1 MB in circuit programmable FLASH memory for user program
- Up to 2 MB in circuit programmable FLASH memory for user data
- Built-in replaceable lithium battery
- LED state indicators
- Low power consumption
- Process-Pascal programmable
- Automatic checksum control of program memory after each reset

## Introduction

The PD 600 series of Distributed Process Intelligence units - DPIs - has been developed as the 3<sup>rd</sup> generation of P-NET fieldbus programmable master devices, for use as distributed computing elements within highly complex as well as simple process control systems. The PD 600 series is part of a new family of standard process control devices, which can be mounted on a DIN rail.

When mounted, communication is automatically enabled through the Light-Link interface. Power is applied to all devices on the same rail by a common power bar. These facilities make mounting, connection, replacement and addition of devices very quick and easy.

## Communication Interface

Channel 1 is a standard P-NET RS-485 communication channel for communicating with other P-NET devices outside the cluster, i.e. the rest of the system.

Channel 2 is a P-NET Light-Link communication channel intended for communicating with other locally mounted P-NET devices using the optical Light-Link interface.

## Programming

The PD 600 DPI is programmed in Process-Pascal, which is an extension of standard Pascal, allowing easy declaration and utilisation of P-NET variables and objects. Programs are developed and compiled on a standard PC, then downloaded directly via a P-NET interface. Program code can be downloaded to FLASH memory.

The PD 600 DPI series devices have the channels shown in the following table.

Channel		
No.	Name	Description
0	Service	Service channel
1	RS485Port	Communication channel, RS-485, P-NET mode or data mode
2	LightPort	Communication channel, Light-Link, P-NET mode or data mode
5	OpSysCh	Program channel for operating system
6	PPPProgCh	Program channel for Process-Pascal

# Memory

The PD 600 DPI is available with 4 different memory versions: Small, Medium, Medium+ and Large. The amount and type of memory for each version is shown in the table.

Type	RAM *)	Program Flash	Data Flash
PD 600 S	64 Kbytes	64 Kbytes	128 KBytes
PD 600 M	480 Kbytes	512 Kbytes	1024 Mbytes
PD 600 M+	992 KBytes	512 KBytes	1024 KBytes
PD 600 L	480 Kbytes	1024 Mbytes	2048 Mbytes

\*) 2Kbytes of RAM reserved for system variables.

A PD 600 DPI series device is equipped with 2 different memory types, with different characteristics. These memory types are described in the following.

The RAM memory is battery backed, and is used for static and temporary local and global Process-Pascal variables and the Process-Pascal stack. Data in RAM is preserved after a power failure, but not after a master reset of the device.

The FLASH memory can be reprogrammed 100 000 times.

The Program FLASH memory is used for Process-Pascal programs. The Data FLASH memory is used for static, global Process-Pascal variables, which are not changed very often. The FLASH memory is organized into 2 Kbytes blocks. Storing in FLASH memory will take minimum 0.5 ms pr. word. Data in FLASH is preserved, even after applying a master reset to the device. Refer to UserFLASH for further information on how to use FLASH memory for Process-Pascal variables.

# Block Schematic

The following figure provides a block diagram showing the internal structure of a PD 600 DPI.

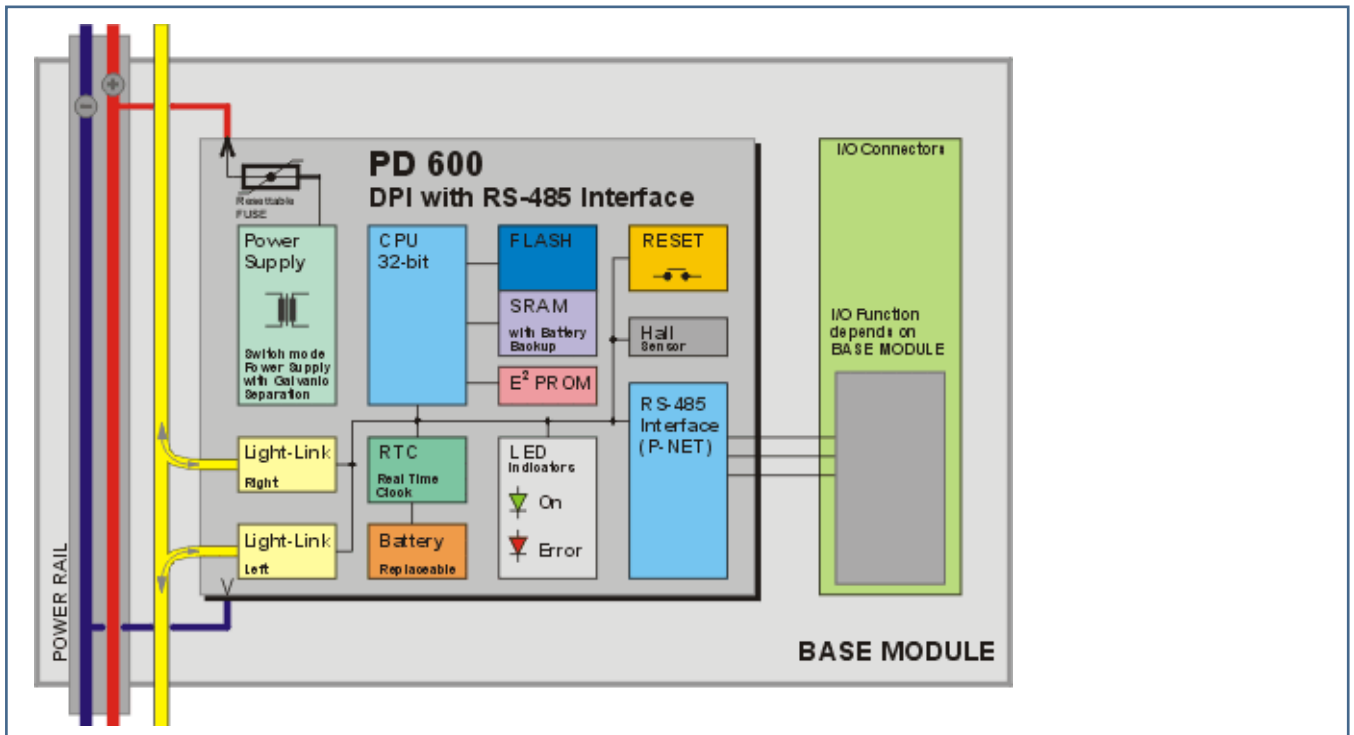

## LED Indicators

A PD 600 DPI series device is equipped with 2 LED indicators, “Error” (red) and “On” (green). The state of the device is indicated by the LEDs, according to the scheme shown in the table.

Meaning	Error (Red)	On (Green)
No power	OFF	OFF
Error, not running	ON	OFF
Process-Pascal not running	OFF	Flash, 2 Hz
Process-Pascal running	OFF	ON
Power supply voltage too low	Flash, 0.5 Hz	OFF
Error, Process-Pascal not running	ON	Flash. 2 Hz
Error, Process-Pascal running	ON	ON

Power supply voltage too low occurs when MaxPowerdownTime is  $\leq 0$ , and the power supply voltage is below approximate 18 V.

## Wiring Diagram

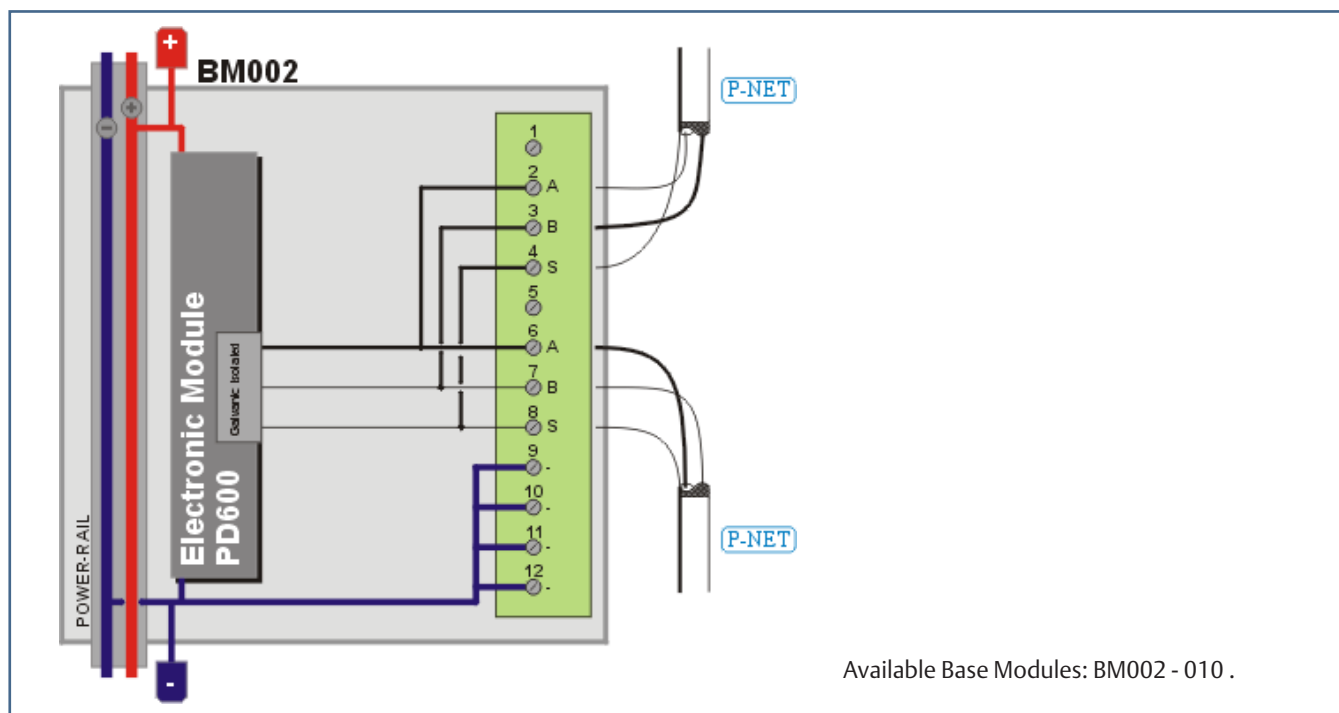

## Technical Specifications

<b>Weight</b>	140 grams approx.
<b>Power supply</b>	18 to 32 VDC
<b>Ripple</b>	max. 5%
<b>Power consumption @ 24VDC</b>	
<b>Operating</b>	max. 50 mA
<b>Current at power up</b>	max. 100 mA
<b>Operation Temperature</b>	-25 °C to + 70 °C
<b>Storage temperature</b>	-40 °C to + 85 °C
<b>Interface</b>	RS-485, Light Link
<b>Replaceable battery</b>	Panasonic BR 1632

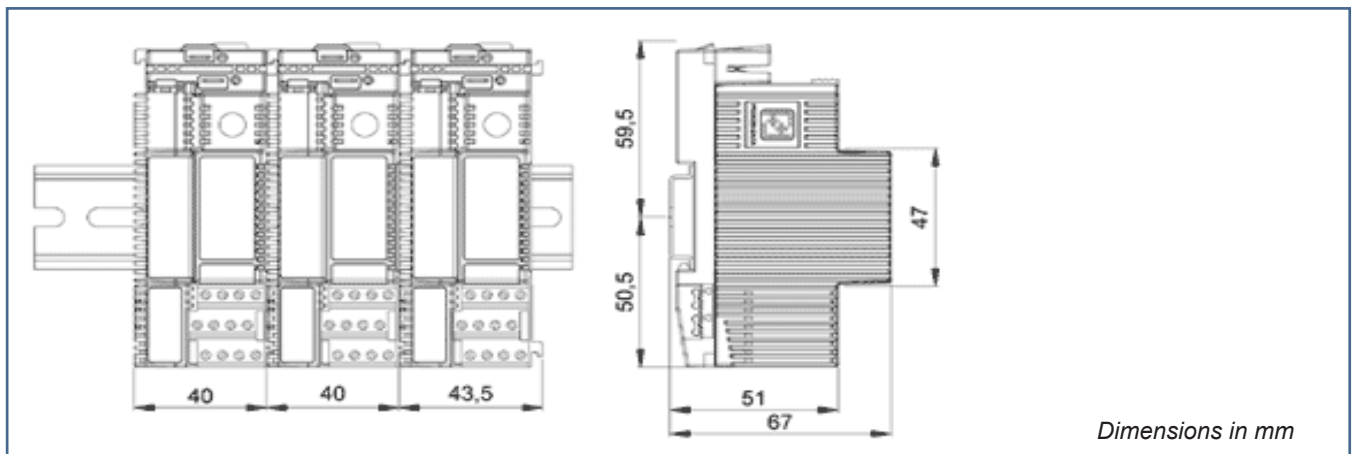

## Battery Backup

A PD 600 DPI series device is equipped with a replaceable lithium battery for real time clock and RAM backup. The battery is not rechargeable. If the device is constantly powered, the lifetime

of the battery is approximate 7 years. If the device is constantly un-powered, the lifetime of the battery is approximate 3 years.

## Real Time Clock

The devices are equipped with a real time clock circuit with battery backup. Maximum deviation is approximate 3 minutes per month over the full temperature range, and approximate

1 minute per month at 25 °C. The same circuit is used for the Process-Pascal timer system, ensuring that the real time clock and the Process-Pascal timers are synchronized.

## Maritime Approvals

Meets the requirements of all the major international marine classification societies.

For more information see PDS for the PD Series 600 Introduction.

### **Emerson Process Management**

Damcos A/S  
Aaderupvej 41  
DK-4700 Naestved  
T +45 5578 7200  
F +45 5578 7272

[www.EmersonProcess.com/mtm](http://www.EmersonProcess.com/mtm)

### **Emerson Process Management**

Rosemount Tank Radar AB  
Box 13045  
SE-40251 Sweden  
T +46 31 337 00 00  
F +46 31 25 30 22

[www.EmersonProcess.com/mtm](http://www.EmersonProcess.com/mtm)

©2015 Emerson Process Management. All rights reserved.

The Emerson logo is a trademark and service mark of Emerson Electric Co. Rosemount and the Rosemount logotype are registered trademarks of Rosemount Inc. Damcos and the Damcos logotype are trademarks of Damcos A/S. Damcos A/S and Rosemount Tank Radar AB are members of the Emerson Process Management family of companies. All other marks are the property of their respective owners.

The contents of this publication are presented for information purposes only, and while effort has been made to ensure their accuracy, they are not to be construed as warranties or guarantees, express or implied, regarding the products or services described herein or their use or applicability. All sales are governed by our terms and conditions, which are available on request. We reserve the right to modify or improve the designs or specifications of our products at any time without notice.

Damcos A/S and Rosemount Tank Radar AB accepts no responsibility for any errors that may appear in this publication.