

Introduction

This Installation Guide provides instructions for installation, startup and adjustment. To receive a copy of the Instruction Manual, contact your local Sales office or view a copy at www.fisherregulators.com. For further information refer to: Type 63EG-98HM Instruction Manual, form 5475, D102630X012.

P.E.D. Categories

This product may be used as a safety accessory with pressure equipment in the following Pressure Equipment Directive 97/23/EC categories.

PRODUCT SIZE	CATEGORY	FLUID TYPE
DN 50 to 150 and 200x150 / 2 to 6 and 8x6 NPS	II	1

Specifications

Main Valve Body and End Connection Styles⁽¹⁾

See Table 2

Maximum Design Pressure⁽¹⁾

41.4 bar / 600 psig or body rating limit, whichever is lower

Body Sizes

Type 63EG-98HM main valve: DN 50, 80, 100, 150 and 200 x 150 / NPS 2, 3, 4, 6 or 8 x 6

Type MR98H Pilot: DN 15 / 1/2 in.

Maximum Operating Relief (Inlet) Pressure Including Buildup⁽¹⁾⁽²⁾

31.0 bar / 450 psig or body rating limit, whichever is lower

Maximum Outlet Pressure⁽¹⁾⁽²⁾

31.0 bar / 450 psig

Maximum Differential Pressure⁽¹⁾

27.6 bar / 400 psig

Proof Test Pressure

All Pressure Retaining Components have been proof tested per Directive 97/23/EC - Annex 1, Section 7.4

Relief Set Pressure/Backpressure Control Ranges⁽¹⁾⁽³⁾

1.0 to 2.4 bar / 15 to 35 psig; 1.7 to 5.2 bar / 25 to 75 psig; 4.8 to 9.7 bar / 70 to 140 psig; 9.0 to 13.8 bar / 130 to 200 psig and 10.3 to 25.9 bar⁽⁴⁾ / 150 to 375 psig⁽⁴⁾

Differential and Buildup Pressure Requirements⁽¹⁾

See Table 1

Temperature Capabilities⁽¹⁾

Fluorocarbon (FKM): -18 to 149°C / 0 to 300°F
hot water limited to 82°C / 180°F

Ethylene propylene (EPR):

Steel: -29 to 177°C / -20 to 350°F

Stainless steel: -40 to 177°C / -40 to 350°F

Perfluoroelastomer (FFKM): -18 to 232°C / 0 to 450°F

Installation

WARNING

Only qualified personnel shall install or service a relief valve or backpressure regulator. Relief valve or backpressure regulator should be installed, operated and maintained in accordance with international and applicable codes and regulations and Emerson Process Management Regulator Technologies, Inc. instructions.

If using a relief valve or backpressure regulator on a hazardous or flammable fluid service, personal injury and property damage could occur due to fire or explosion of vented fluid that may have accumulated. To prevent such injury or damage, provide piping or tubing to vent the fluid to a safe, well-ventilated area or containment vessel. Also, when venting a hazardous fluid, the piping or tubing should be located far enough away from any buildings or windows so to not create a further hazard and the vent opening should be protected against anything that could clog it.

Personal injury, equipment damage or leakage due to escaping fluid or bursting of pressure-containing parts may result if this relief valve or backpressure regulator is overpressured or is installed where service conditions could exceed the limits given in the Specifications section or where conditions exceed any ratings of the adjacent piping or piping connections.

To avoid such injury or damage, provide pressure-relieving or pressure-limiting devices (as required by the appropriate code, regulation or standard) to prevent service conditions from exceeding limits.

Additionally, physical damage to the relief valve or backpressure regulator could result in personal injury and property damage due to escaping fluid.

To avoid such injury and damage, install the relief valve or backpressure regulator in a safe location.

Clean out all pipelines before installation of the relief valve or backpressure regulator and check to be sure the relief valve or backpressure regulator has not been damaged or has collected foreign material during shipping. For NPT bodies, apply pipe compound to the external pipe threads. For flanged bodies, use suitable line gaskets and approved piping and bolting practices. Install the relief valve or backpressure regulator in any position desired, unless otherwise specified, but be sure flow through the body is in the direction indicated by the arrow on the body.

1. The pressure/temperature limits in this Installation Guide and any applicable standard or code limitation should not be exceeded.
2. Fluorocarbon (FKM) diaphragm is limited to 20.7 bar / 300 psig.
3. Set pressure is defined as the pressure at which the pilot starts-to-discharge.
4. 10.3 to 25.9 bar / 150 to 375 psig spring range is for the Type MR98HH pilot construction.



Type 63EG-98HM

Table 1. Minimum and Maximum Differential and Buildup Required for Wide-Open Flow

BODY SIZE	MAIN VALVE SPRING RANGE, SPRING PART NUMBER AND COLOR	MINIMUM DIFFERENTIAL PRESSURE REQUIRED FOR FULL STROKE ⁽¹⁾	BUILDUP OVER SET PRESSURE REQUIRED FOR FULL STROKE	MAXIMUM DIFFERENTIAL PRESSURE
DN 50 / 2 in.	0.69 to 2.8 bar / 10 to 40 psig 14A6768X012, Yellow	1.5 bar / 22 psig	0.48 bar / 7 psig	2.8 bar / 40 psig
	2.1 to 8.6 bar / 30 to 125 psig 14A6626X012, Green	2.1 bar / 30 psig	0.6 bar / 9 psig	8.6 bar / 125 psig
	5.9 to 27.6 bar / 85 to 400 psig 14A6628X012, Red	6.2 bar / 90 psig	1.6 bar / 23 psig	28 bar ⁽²⁾ / 400 psig ⁽²⁾
DN 80 / 3 in.	0.69 to 2.8 bar / 10 to 40 psig 14A6771X012, Yellow	1.3 bar / 19 psig	0.34 bar / 5 psig	2.8 bar / 40 psig
	2.1 to 8.6 bar / 30 to 125 psig 14A6629X012, Green	1.7 bar / 25 psig	0.48 bar / 7 psig	8.6 bar / 125 psig
	5.9 to 27.6 bar / 85 to 400 psig 14A6631X012, Red	4.1 bar / 60 psig	1.2 bar / 17 psig	28 bar ⁽²⁾ / 400 psig ⁽²⁾
DN 100 / 4 in.	0.69 to 2.8 bar / 10 to 40 psig 14A6770X012, Yellow	1.1 bar / 16 psig	0.28 bar / 4 psig	2.8 bar / 40 psig
	2.1 to 8.6 bar / 30 to 125 psig 14A6632X012, Green	1.4 bar / 20 psig	0.4 bar / 6 psig	8.6 bar / 125 psig
	5.9 to 27.6 bar / 85 to 400 psig 14A6634X012, Red	3.8 bar / 55 psig	1.1 bar / 16 psig	28 bar ⁽²⁾ / 400 psig ⁽²⁾
DN 150 / 6 in. DN 200 x 150 / 8 x 6 in.	0.69 to 2.8 bar / 10 to 40 psig 15A2253X012, Yellow	1.1 bar / 16 psig	0.28 bar / 4 psig	2.8 bar / 40 psig
	2.1 to 8.6 bar / 30 to 125 psig 14A9686X012, Green	1.4 bar / 20 psig	0.4 bar / 6 psig	8.6 bar / 125 psig
	5.9 to 27.6 bar / 85 to 400 psig 15A2615X012, Red	3.8 bar / 55 psig	1.1 bar / 16 psig	28 bar ⁽²⁾ / 400 psig ⁽²⁾

1. Minimum differential is defined as the difference between the inlet pressure to the main valve body and the exhaust pressure from the pilot outlet. If the pilot exhaust is piped to the immediate downstream system, the differential is between the inlet and outlet pressure of the backpressure regulator. The pilot exhaust also may be discharged to atmosphere.
2. CL150 steel body is limited to 20 bar / 290 psig.

Table 2. Body Sizes, End Connection Styles and Main Valve Body Ratings

MAIN VALVE BODY SIZE	MAIN VALVE BODY MATERIAL	END CONNECTION STYLES ⁽¹⁾	STRUCTURAL DESIGN RATING
DN 50 / 2 in. DN 80 / 3 in. DN 100 / 4 in. DN 150 / 6 in. DN 200 x 150 / 8 x 6 in.	WCC Steel	NPT or DN 50 / 2 in. only	102 bar / 1480 psig
		CL150 RF	20 bar / 290 psig
		CL300 RF	51.0 bar / 740 psig
		CL600 RF	102 bar / 1480 psig

1. Ratings and end connections for other than ANSI standard can usually be provided. Contact your local Sales Office for assistance.

Note

It is important that the relief valve or backpressure regulator be installed so that the vent hole in the spring case is unobstructed at all times. For outdoor installations, the relief valve or backpressure regulator should be located away from vehicular traffic and positioned so that water, ice and other foreign materials cannot enter the spring case through the vent. Avoid placing the relief valve or backpressure regulator beneath eaves or downspouts and be sure it is above the probable snow level.

Overpressure Protection

Maximum inlet pressures depend upon body materials and temperatures. Refer to the nameplate for the maximum inlet pressure of the relief valve or backpressure regulator. The relief valve or backpressure regulator should be inspected for damage after any overpressure condition. **Fisher® relief valve or backpressure regulators are NOT ASME safety relief valves.**

Startup

The relief valve or backpressure regulator is factory set at approximately the midpoint of the spring range or the pressure requested, so an initial adjustment may be required to give the desired results. With proper installation completed and relief valves properly adjusted, slowly open the upstream and downstream shutoff valves (if applicable).

Adjustment

To change the control pressure, remove the closing cap or loosen the locknut and turn the adjusting screw clockwise to increase control pressure or counterclockwise to decrease pressure. Monitor the inlet pressure with a test gauge during the adjustment. Replace the closing cap or tighten the locknut to maintain the desired setting.

Taking Out of Service (Shutdown)



To avoid personal injury resulting from sudden release of pressure, isolate the relief valve or backpressure regulator from all pressure before attempting disassembly.

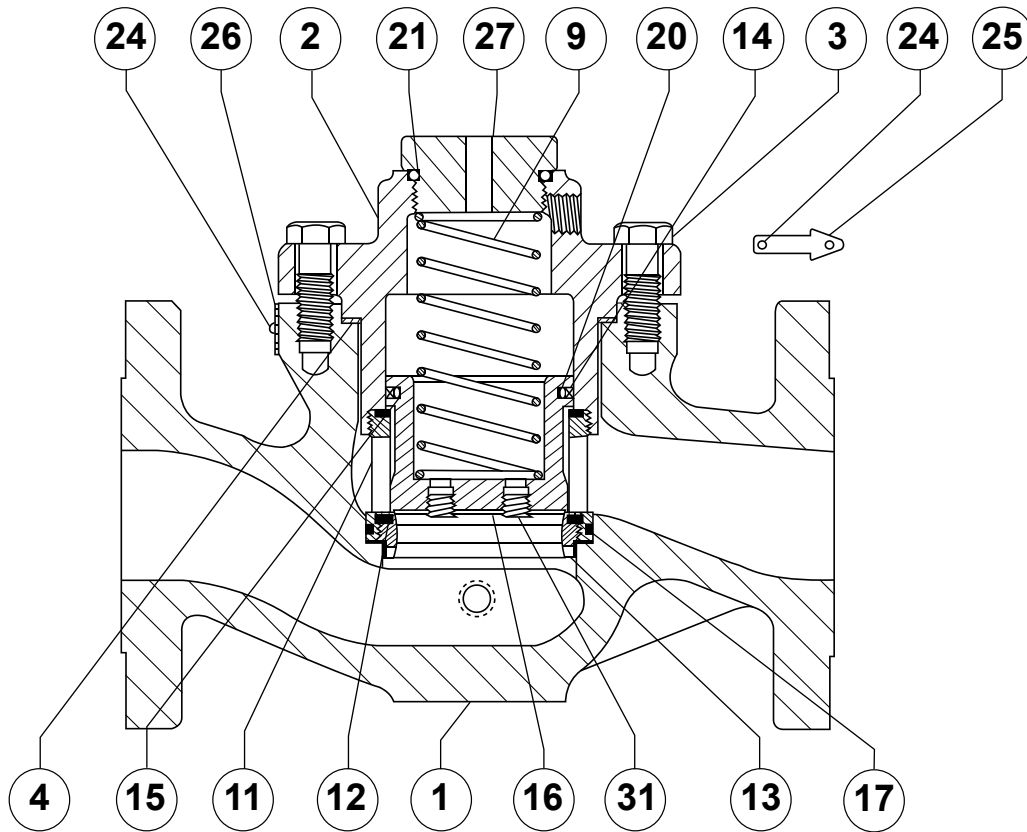

35A3174-A
A2812

Figure 1. Type 63EG Main Valve

Parts List

Type 63EG Main Valve

Key	Description
1	Main Valve Body
2	Body Flange
3	Cap Screw
3	Stud Bolt
4	Gasket
9	Spring
11	Cage
12	Port Seal
13	Seat Ring
14	Piston Ring
15	Upper Seal
16	Valve Plug
17	Cage O-ring
20	Plug O-ring
21	O-ring
24	Drive Screw
25	Flow Arrow
26	Nameplate
27	Travel Indicator Plug
29	Hex Nut
31	Pipe Plug
32	NACE Tag
33	Tag Wire
34	Pipe Nipple
35	Tubing
36	Restrictor
37	Connector

Type MR98H Pilot

Key	Description
1	Regulator Body
2	Spring Case
3*	Orifice
4*	Valve Plug
5	Bottom Plug
7	Valve Plug Guide
8	Lower Spring Seat
9	Upper Spring Seat
10	Pusher Post
11	Control Spring
12*	Diaphragm
15	Adjusting Screw
16	Cap Screw
17	Jam Nut
24	Machine Screw
25	O-ring Retainer
28	Lock Washer
29*	Gasket
31	Locknut
58	Washer
59	Valve Plug O-ring
63*	Bottom Seal Plug

*Recommended spare part

Type 63EG-98HM

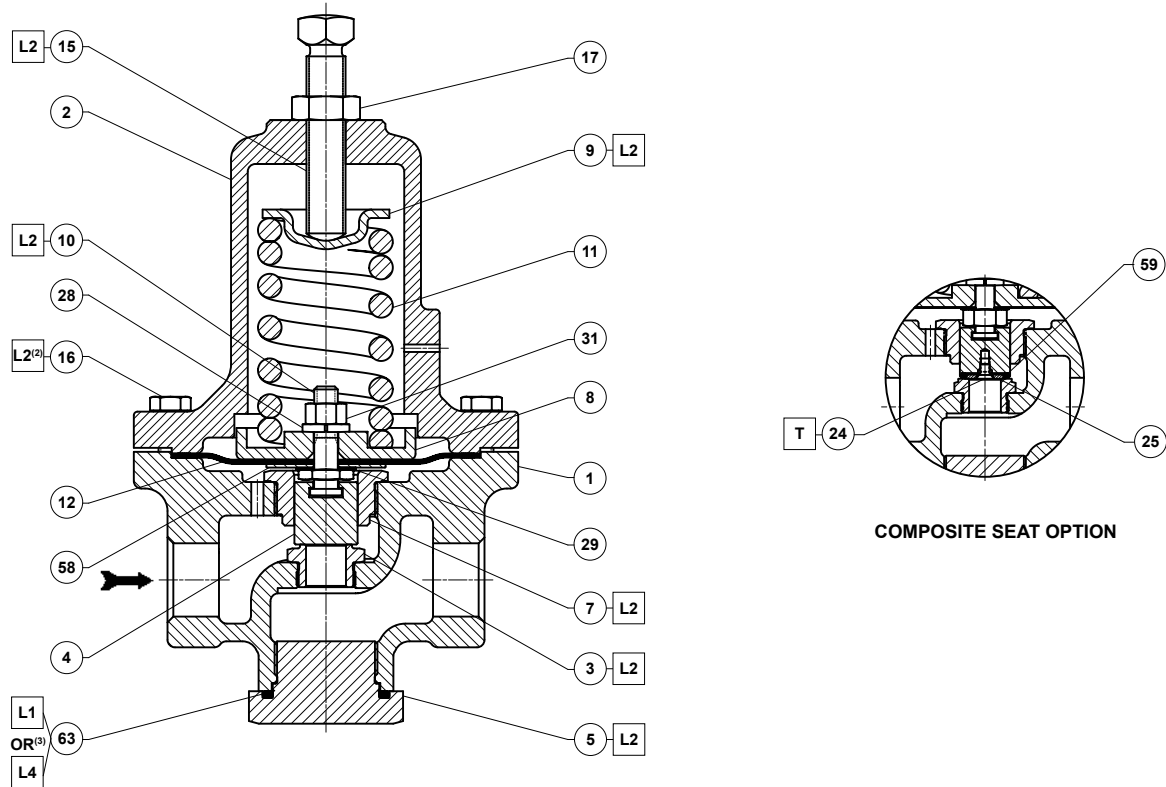

GF04916

APPLY⁽¹⁾:

T = THREAD LOCKER

L1 = GENERAL PURPOSE PTFE OR LITHIUM GREASE FOR O-RINGS

L2 = ANTI - SEIZE COMPOUND

L4 = GRAPHITE SEALANT FOR GRAPHITE RING

1. Lubricants and sealants must be selected such that they meet the temperature requirements.

2. Apply L2 (anti-seize compound) on key 16 for stainless steel bolts.

3. Apply L4 (graphite sealant) instead of L1 (general purpose PTFE or lithium grease) on key 63 for graphite ring.

Figure 2. Type MR98H Pilot Assembly

Industrial Regulators

Emerson Process Management Regulator Technologies, Inc.

USA - Headquarters
McKinney, Texas 75070 USA
Tel: +1 800 558 5853
Outside U.S. +1 972 548 3574

Asia-Pacific
Shanghai 201206, China
Tel: +86 21 2892 9000

Europe
Bologna 40013, Italy
Tel: +39 051 419 0611

Middle East and Africa
Dubai, United Arab Emirates
Tel: +971 4811 8100

Natural Gas Technologies

Emerson Process Management Regulator Technologies, Inc.

USA - Headquarters
McKinney, Texas 75070 USA
Tel: +1 800 558 5853
Outside U.S. +1 972 548 3574

Asia-Pacific
Singapore 128461, Singapore
Tel: +65 6770 8337

Europe
Bologna 40013, Italy
Tel: +39 051 419 0611
Chartres 28008, France
Tel: +33 2 37 33 47 00

Middle East and Africa
Dubai, United Arab Emirates
Tel: +971 4811 8100

TESCOM

Emerson Process Management Tescom Corporation

USA - Headquarters
Elk River, Minnesota 55330-2445, USA
Tels: +1 763 241 3238
+1 800 447 1250

Europe
Selmsdorf 23923, Germany
Tel: +49 38823 31 287

Asia-Pacific
Shanghai 201206, China
Tel: +86 21 2892 9499

For further information visit www.fisherregulators.com

The Emerson logo is a trademark and service mark of Emerson Electric Co. All other marks are the property of their prospective owners. Fisher is a mark owned by Fisher Controls International LLC, a business of Emerson Process Management.

The contents of this publication are presented for informational purposes only, and while every effort has been made to ensure their accuracy, they are not to be construed as warranties or guarantees, express or implied, regarding the products or services described herein or their use or applicability. We reserve the right to modify or improve the designs or specifications of such products at any time without notice.

Emerson Process Management Regulator Technologies, Inc. does not assume responsibility for the selection, use or maintenance of any product. Responsibility for proper selection, use and maintenance of any Emerson Process Management Regulator Technologies, Inc. product remains solely with the purchaser.