

## Introduction

This installation guide provides instructions for installation, startup, and adjustment. To receive a copy of the instruction manual, contact your local Fisher Sales Office or Sales Representative or view a copy at [www.FISHERregulators.com](http://www.FISHERregulators.com). For further information refer to:

Type 92S Instruction Manual, form 5234, D100637X012.

## P.E.D. Categories

This product may be used as a safety accessory with pressure equipment in the following Pressure Equipment Directive 97/23/EC categories. It may also be used outside of the Pressure Equipment Directive using sound engineering practice (SEP) per table below.

PRODUCT SIZE	CATEGORIES	FLUID TYPE
DN 6 (1/4-inch)	SEP	1

## Specifications

### Maximum Inlet and Outlet Pressures<sup>(1)</sup>

See table 2

### Outlet Pressure Ranges

See table 1

### Proof Test Pressure

All Pressure Retaining Components have been proof tested per Directive 97/23/EC - Annex 1, Section 7.4

### Temperature Capabilities

**Cast Iron:** 208°C (406°F); **Steel:** 260°C (500°F)

operated, and maintained in accordance with international and applicable codes and regulations, and Fisher instructions.

**If the regulator vents fluid or a leak develops in the system, it indicates that service is required. Failure to take the regulator out of service immediately may create a hazardous condition.**

**Personal injury, equipment damage, or leakage due to escaping fluid or bursting of pressure-containing parts may result if this regulator is overpressured or is installed where service conditions could exceed the limits given in the Specifications section, or where conditions exceed any ratings of the adjacent piping or piping connections.**

**To avoid such injury or damage, provide pressure-relieving or pressure-limiting devices (as required by the appropriate code, regulation, or standard) to prevent service conditions from exceeding limits.**

**Additionally, physical damage to the regulator could result in personal injury and property damage due to escaping fluid. To avoid such injury and damage, install the regulator in a safe location.**

Clean out all pipelines before installation of the regulator and check to be sure the regulator has not been damaged or has collected foreign material during shipping. For NPT bodies, apply pipe compound to the male pipe threads. For flanged bodies, use suitable line gaskets and approved piping and bolting practices. Install the regulator in any position desired, unless otherwise specified, but be sure flow through the body is in the direction indicated by the arrow on the body.

## Installation



### WARNING

**Only qualified personnel should install or service a regulator. Regulators should be installed,**

### Note

It is important that the regulator be installed so that the vent hole in the spring case is unobstructed at all times. For outdoor installations, the regulator should be located away from vehicular traffic and positioned so that water, ice, and other foreign materials cannot enter the spring case through the vent. Avoid placing the regulator beneath eaves or downspouts, and be sure it is above the probable snow level.

Table 1. Outlet (Control) Pressure Ranges

PILOT TYPE	OUTLET PRESSURE RANGE, bar (PSIG)
6492L	0,14 to 0,41 (2 to 6)
	0,34 to 1,03 (5 to 15)
	0,90 to 1,7 (13 to 25)
6492H	0,69 to 2,1 (10 to 30)
	1,7 to 5,2 (25 to 75)
	4,8 to 10,3 (70 to 150)
6492HT	1,0 to 6,9 (15 to 100)
	5,5 to 17,2 (80 to 250)

## Overpressure Protection

The recommended pressure limitations are stamped on the regulator nameplate. Some type of overpressure protection is needed if the actual inlet pressure exceeds the maximum operating outlet pressure rating. Overpressure protection should also be provided if the regulator inlet pressure is greater than the safe working pressure of the downstream equipment.

Table 2. Maximum Inlet and Outlet Pressures

TYPE	MAXIMUM ALLOWABLE INLET PRESSURE, bar (PSIG)		MAXIMUM OPERATING OUTLET PRESSURE, bar (PSIG)	MAXIMUM EMERGENCY OUTLET PRESSURE, bar (PSIG)	
	Cast Iron	Steel / Stainless Steel		Cast Iron Body	Steel / Stainless Steel Body
6492HT	---	20,7 (300)	17,2 (250)	---	20,7 (300) or main valve body rating limit, whichever is lower
6492H	17,2 (250)	20,7 (300)	10,3 (150)	17,2 (250) or main valve body rating limit, whichever is lower	20,7 (300) or main valve body rating limit, whichever is lower
6492L	17,2 (250)	20,7 (300)	1,72 (25)	6,9 (100)	6,9 (100)

1. The pressure/temperature limits in this installation guide and any applicable standard or code limitation should not be exceeded.



# Type 6492

Regulator operation below the maximum pressure limitations does not preclude the possibility of damage from external sources or debris in the line. The regulator should be inspected for damage after any overpressure condition.

## Startup

The regulator is factory set at approximately the midpoint of the spring range or the pressure requested, so an initial adjustment may be required to give the desired results. With proper installation completed and relief valves properly adjusted, slowly open the upstream and downstream shutoff valves.

## Adjustment

To change the outlet pressure, remove the closing cap or loosen the locknut and turn the adjusting screw clockwise to increase outlet pressure or counterclockwise to decrease pressure. Monitor the outlet pressure with a test gauge during the adjustment. Replace the closing cap or tighten the locknut to maintain the desired setting.

## Taking Out of Service (Shutdown)



**WARNING**

To avoid personal injury resulting from sudden release of pressure, isolate the regulator from all pressure before attempting disassembly.

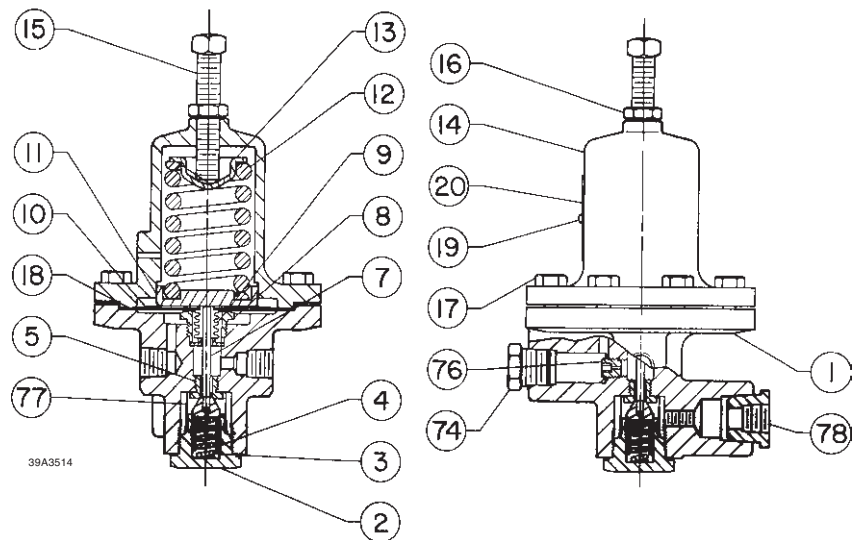

Figure 1. Type 6492H Assembly

## Type 6492L and 6492H Parts List

### Key Description

1	Body
2	Plug Guide
3	Plug Spring
4	Plug
5	Seat Ring
7	Stem
8	Bellows Retainer
9	Bellows
10	Diaphragm
11	Lower Spring Seat
12	Control Spring
13	Upper Spring Seat
14	Spring Case
15	Adjusting Screw
16	Hex Nut
17	Cap Screw
18	Diaphragm Gasket
19	Drive Screw
20	Nameplate
24	Diaphragm Plate Assembly
74	Pipe Plug
76	Bleed Restriction
77	Screen
78	Reducing Bushing
87	Sealing Washer

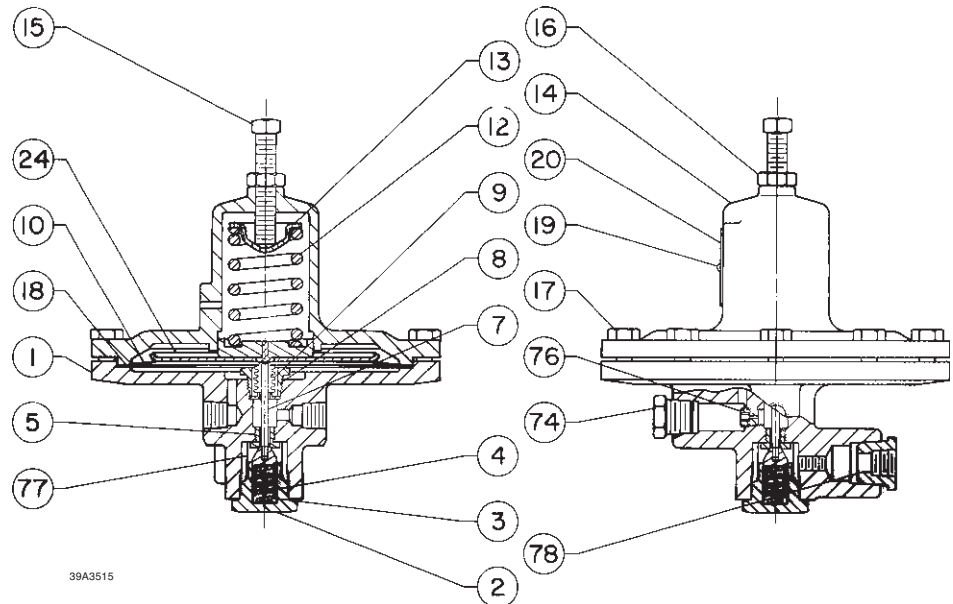

Figure 2. Type 6492L Assembly

©Fisher Controls International, Inc., 2002; All Rights Reserved

Fisher and Fisher Regulators are marks owned by Fisher Controls International, Inc. The Emerson logo is a trade mark and service mark of Emerson Electric Co. All other marks are the property of their respective owners.

The contents of this publication are presented for informational purposes only, and while every effort has been made to ensure their accuracy, they are not to be construed as warranties or guarantees, express or implied, regarding the products or services described herein or their use or applicability. We reserve the right to modify or improve the designs or specifications of such products at any time without notice.

For information, contact Fisher Controls, International:

Within USA (800) 588-5853 – Outside USA (972) 542-0132

Italy – (39) 051-4190-606

Singapore – (65) 770-8320

Mexico – (52) 57-28-0888

Printed in U.S.A.

[www.FISHERregulators.com](http://www.FISHERregulators.com)

