

# Continuous Total Chlorine Measurement and Recording to Meet E.P.A. Discharge Requirements

## BACKGROUND

E.P.A. regulations require those who discharge chlorine to provide a continuous record of total effluent containing chlorine concentration at the outfall to prove that the discharge concentration does not exceed their allowable limit. To meet these requirements the following criteria must be met:

1. The instrument system must be reliable. It must perform for long periods of time before recalibration becomes necessary.
2. Accurate low level measurement with the capability to monitor down to 500 ppb full scale is necessary in many cases.

## INSTRUMENTATION

Total chlorine can be determined using the Rosemount Model TCL. This system is a sample conditioning and mea-

suring system for the continuous determination of total chlorine in water. The conditioning system continuously pumps buffered potassium iodide reagent into the sample. Free and combined chlorine (total chlorine) react with potassium iodide to form an equivalent amount of iodine. An amperometric sensor measures the concentration of iodine and sends its signal to the Rosemount Dual Input Analyzer Solu Comp II Model 1056. The analyzer displays the concentration of total chlorine. Additional choices in instrumentation include two-wire transmitters Model Xmt and Model 5081.

The Sample Conditioning System should be located near the final outfall point. A simple overflow weir maintains the correct flow rate into the low flow cell, and sends any excess sample to drain. The Analyzer (NEMA 4X enclosure) is field mountable and provides multiple outputs for recording and controlling. Figure 1 illustrates this process from water intake to discharge.

## INSTRUMENTATION: Total Chlorine Measurement

### Model TCL Sample Conditioning System

- NO METAL WETTED PARTS. Ideal for seawater
- LOW SAMPLE FLOW (about 15 mL/minute) means little waste
- REAGENT-BASED SYSTEM measures true total chlorine
- FIVE GALLONS OF REAGENT lasts two months

### Model 1056-24 Chlorine Analyzer (shown)

- LARGE, BACK-LIT DISPLAY with easy to use interface.
- TWO INDEPENDENT OUTPUTS
- THREE FULLY PROGRAMMABLE ALARMS
- INPUT FILTER improves stability at low concentrations

### Model 499A CL-02 Sensor

- MEMBRANE-COVERED AMPEROMETRIC SENSOR
- NO TOOLS REQUIRED to change membrane
- MAINTENANCE TAKES ONLY A FEW MINUTES a month
- VARIOPOL CONNECTOR OPTION allows the sensor to be replaced without removing and rewiring cable



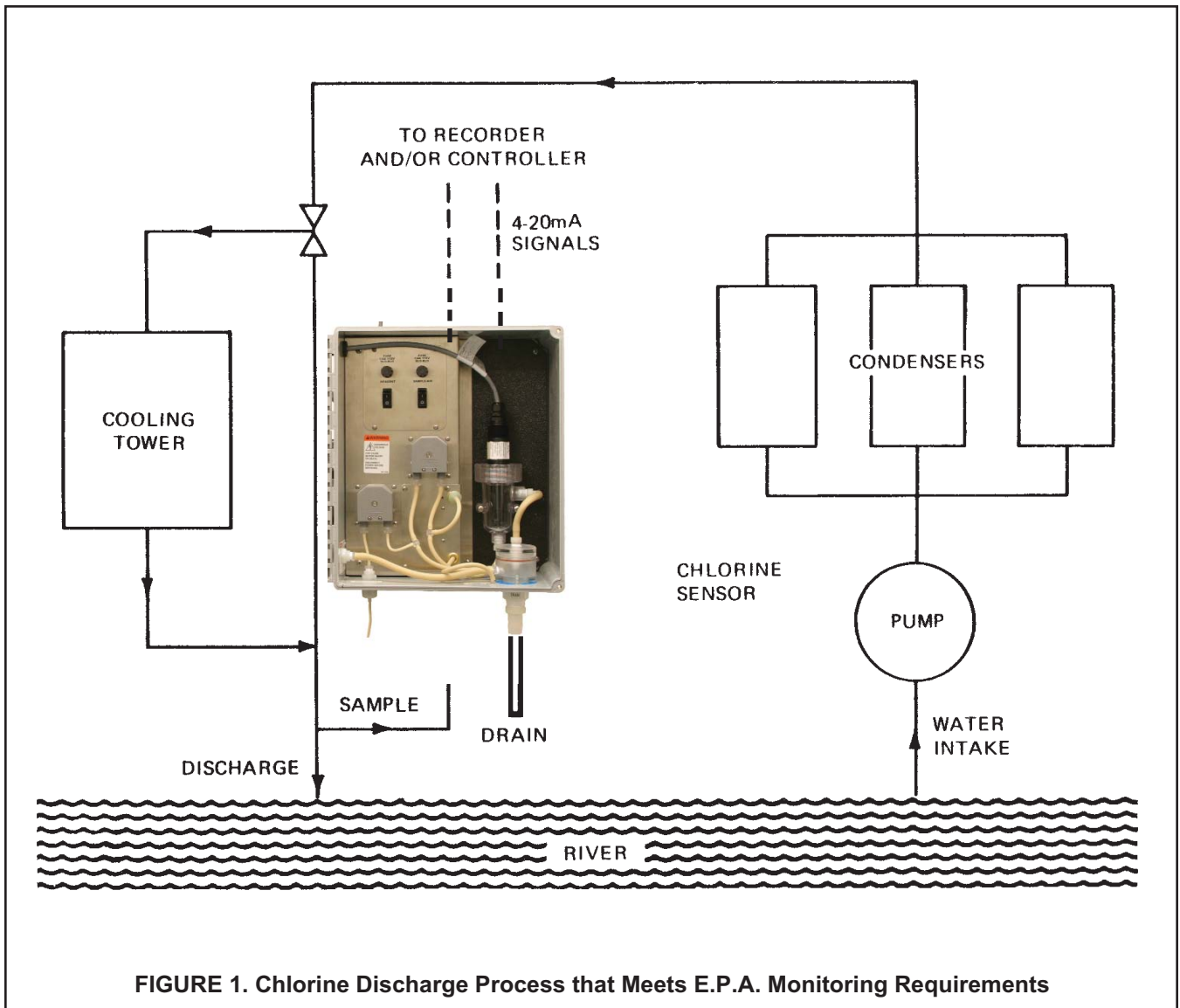

*The right people,  
the right answers,  
right now.*

ROSEMOUNT ANALYTICAL  
CUSTOMER SUPPORT CENTER  
1-800-854-8257



ON-LINE ORDERING NOW AVAILABLE ON OUR WEB SITE  
<http://www.raihome.com>



Credit Cards for U.S. Purchases Only.



**Emerson Process Management**

**Liquid Division**

2400 Barranca Parkway  
Irvine, CA 92606 USA  
Tel: (949) 757-8500  
Fax: (949) 474-7250

<http://www.raihome.com>

© Rosemount Analytical Inc. 2009

