

# High Purity pH Sensor



## ESSENTIAL INSTRUCTIONS

### READ THIS PAGE BEFORE PROCEEDING!

Rosemount Analytical designs, manufactures, and tests its products to meet many national and international standards. Because these instruments are sophisticated technical products, you must properly install, use, and maintain them to ensure they continue to operate within their normal specifications. The following instructions must be adhered to and integrated into your safety program when installing, using, and maintaining Rosemount Analytical products. Failure to follow the proper instructions may cause any one of the following situations to occur: Loss of life; personal injury; property damage; damage to this instrument; and warranty invalidation.

- Read all instructions prior to installing, operating, and servicing the product. If this Instruction Manual is not the correct manual, telephone 1-800-654-7768 and the requested manual will be provided. Save this Instruction Manual for future reference.
- If you do not understand any of the instructions, contact your Rosemount representative for clarification.
- Follow all warnings, cautions, and instructions marked on and supplied with the product.
- Inform and educate your personnel in the proper installation, operation, and maintenance of the product.
- Install your equipment as specified in the Installation Instructions of the appropriate Instruction Manual and per applicable local and national codes. Connect all products to the proper electrical and pressure sources.
- To ensure proper performance, use qualified personnel to install, operate, update, program, and maintain the product.
- When replacement parts are required, ensure that qualified people use replacement parts specified by Rosemount. Unauthorized parts and procedures can affect the product's performance and place the safe operation of your process at risk. Look alike substitutions may result in fire, electrical hazards, or improper operation.
- Ensure that all equipment doors are closed and protective covers are in place, except when maintenance is being performed by qualified persons, to prevent electrical shock and personal injury.

## **DANGER — HAZARDOUS AREA INSTALLATION**

Installations near flammable liquids or in hazardous area locations must be carefully evaluated by qualified on site safety personnel. This sensor is not Intrinsically Safe or Explosion Proof.

To secure and maintain an intrinsically safe installation, the certified safety barrier, transmitter, and sensor combination must be used. The installation system must comply with the governing approval agency (FM, CSA or BASEEFA/ CENELEC) hazardous area classification requirements. Consult your analyzer/ transmitter instruction manual for details.

Proper installation, operation and servicing of this sensor in a Hazardous Area Installation is entirely the responsibility of the user.

## **CAUTION SENSOR/PROCESS APPLICATION COMPATIBILITY**

**The wetted sensor materials may not be compatible with process composition and operating conditions. Application compatibility is entirely the responsibility of the user.**

## About This Document

This manual contains instructions for installation and operation of the Model 320HP High Purity pH Sensor. The following list provides notes concerning all revisions of this document.

<b><u>Rev. Level</u></b>	<b><u>Date</u></b>	<b><u>Notes</u></b>
0	1/01	This is the initial release of the product manual. The manual has been reformatted to reflect the Emerson documentation style and updated to reflect any changes in the product offering.
A	7/02	Updated multiple drawings throughout.
B	8/02	Added drawing 40105544.
C	11/02	Revised figure 2-5 on page 6.
D	1/03	Updated drawings on pages 9 & 10.
E	11/03	Update figure 2-5.
F	5/04	Add wiring drawings to models Xmt & 5081.
G	12/04	Updated Figure 2-9 on page 8.
H	1/05	Revised Figures 2-5 and 2-12; delete Figures 2-3 and 2-6
I	5/05	Revised drawings on pages 8 & 9.
J	5/06	Revised Table 5-1 on page 19.

### Emerson Process Management

#### Liquid Division

2400 Barranca Parkway  
Irvine, CA 92606 USA  
Tel: (949) 757-8500  
Fax: (949) 474-7250

<http://www.raihome.com>



**EMERSON**  
Process Management

# MODEL 320HP HIGH PURITY PH SENSOR

## TABLE OF CONTENTS

Section	Description	Page
<b>1.0</b>	<b>DESCRIPTION AND SPECIFICATIONS .....</b>	<b>1</b>
1.1	Features and Applications.....	1
1.2	Operation .....	1
1.3	Sensor Specifications.....	1
1.4	Ordering Information .....	2
<b>2.0</b>	<b>MECHANICAL INSTALLATION .....</b>	<b>3</b>
2.1	General .....	3
2.2	Unpacking .....	3
2.3	Preparation for Installation .....	3
2.4	Installation Inspection .....	5
<b>3.0</b>	<b>OPERATION .....</b>	<b>11</b>
3.1	General .....	11
3.2	Calibration .....	11
<b>4.0</b>	<b>MAINTENANCE AND TROUBLESHOOTING .....</b>	<b>12</b>
4.1	General .....	12
4.2	Preventative Maintenance .....	12
4.3	Troubleshooting .....	13
4.4	Maintenance .....	14
<b>5.0</b>	<b>PARTS LIST .....</b>	<b>19</b>
5.1	General .....	19
<b>6.0</b>	<b>RETURN OF MATERIALS .....</b>	<b>21</b>
6.1	General .....	21
6.2	Warranty Repair .....	21
6.3	Non Warranty Repair .....	21

# MODEL 320HP HIGH PURITY PH SENSOR

## TABLE OF CONTENTS (CONT.)

### LIST OF FIGURES

Figure No.	Title	Page
2-1	Liquid Junction Installation.....	3
2-2	Model 320HP Dimensional Drawing .....	4
2-3	Model 320HP-50/51/54 Wiring to Models 1054A/B, 2054, 2081, 1181, 1003, 1050 .....	5
2-4	Model 320HP-55 Wiring to Models 54/54e, 81, 3081, 4081, and 5081 .....	6
2-5	Model 320HP-55 Wiring to Model Xmt-P-HT-10.....	7
2-6	Model 320HP-58 Wiring to Model Xmt-P-HT-10.....	7
2-7	Model 320HP-58 Wiring to Models 54e, 81, 3081, 4081, and 5081 .....	8
2-8	Model 320HP-55 Wiring to Model 1055-22-32 .....	9
2-9	Model 320HP-58 Wiring to Model 1055-22-32 .....	9
2-10	Model 320HP Wiring to Model 1055-01-10-22 .....	10
3-1	Buffer Cup Fixture .....	11
4-1	Preamplifier Check .....	14
4-2	Reference Electrode Check.....	16
4-3	Glass Electrode Test Method .....	17
4-4	Temperature Compensator Check .....	17
5-1	Model 320 HP (Front View and Side View) Component Locator.....	20

### LIST OF TABLES

Table No.	Title	Page
4-1	Troubleshooting without Diagnostics .....	13
4-2	Troubleshooting with Diagnostics .....	15
4-3	Temperature vs. Resistance .....	18
4-4	$R_0$ & $R_1$ Value for Temperature Compensation Elements .....	18
5-1	Parts List.....	19

## SECTION 1.0

# GENERAL DESCRIPTION AND SPECIFICATIONS

- CORROSION-RESISTANT, WEATHERPROOF CONSTRUCTION permits installation in almost any environment.
- UNIQUE SENSOR DESIGN provides accurate, stable pH measurement in high purity water.
- ELECTRONICALLY SHIELDED GLASS ELECTRODE protects against electrostatic noise pickup.
- INCLUDES ROTAMETER AND NEEDLE VALVE to assure an accurate, stable measurement.
- CONVENIENT SHELF to hold electrodes for buffer calibration.

### 1.1 FEATURES AND APPLICATIONS

The Rosemount Analytical Model 320HP High-Purity pH Sensor is uniquely designed for pH measurement in aqueous solutions of very low dissolved solids content (below 50 microsiemens). The sensor assembly consists of a stainless steel flow cell, glass electrode, a double junction Kynar<sup>1</sup> reference cell with specially designed liquid junction, temperature compensator, rotameter, needle valve and a weatherproof junction box containing an optional preamplifier. All components are mounted on an ABS plate which may be attached to a wall or clamped (optional) to a two-inch pipe.

The electrical resistance of high-purity water is very high, typically one megohm or more. Such liquids can generate a considerable static charge when flowing over an essentially nonconductive (plastic) surface. An adequate discharge path to a good earth ground must be provided for this static charge; otherwise, it can be easily picked up by the high impedance pH electrode causing excessive noise in the measuring signal. The well-grounded metallic flow cell in the Model 320HP High-Purity pH Sensor surrounds the pH electrode and provides an effective discharge path to ground for any static charges. It also serves as an electronic shield against outside interference from AC power lines, arcing electrical equipment, and other similar sources of noise.

### 1.2 OPERATION

Accurate pH measurement in high-purity water depends on a stable reference junction potential, and this requirement is met by the unique design of the reference junction in the high-purity sensor. The construction of the junction serves to minimize any changes in junction potential which are caused by variations in flow rate of the high-purity water over the junction surface. The flowmeter and needle valve aid in maintaining the low, constant sample flow required for a stable reference junction potential.

### 1.3 SENSOR SPECIFICATIONS

**Style:** Flow-through

**Wetted Materials:** Kynar, Buna-N, glass, stainless steel, ABS, Teflon<sup>2</sup> Viton<sup>2</sup>, Polypropylene

**Range:** 0 to 14 pH

**Sample Temperature:** 4°C to 71°C (39°F to 160°F)

**Sample Pressure Required:** 5 to 10 psig

**Sample Flow Rate:** Constant in the region of 0.8 to 2.4 gal/hour

**Process Connections:** 1/4-inch tube

**Reference Electrode:** Sealed, double junction

**Measuring Electrode:** Glass, GPHT (0-13pH)

<sup>1</sup> Kynar is a registered trademark of Elf Atochem North America, Inc.

<sup>2</sup> Teflon and Viton are registered trademarks of E.I. duPont de Nemours & Comp.

## 1.4 ORDERING INFORMATION

**Model 320HP Flow Through High-Purity pH Sensor** is designed for use when conductivity is below 50  $\mu$ S. The sensor includes a 316 stainless steel flow cell, a double junction Kynar reference cell with specially designed liquid junction, pH glass electrode, temperature compensator, and a weatherproof junction box containing an optional preamplifier. A rotameter and a needle valve are included on the input side of the flow cell for monitoring and control of the sample flow. All components are mounted on an ABS plate which is suitable for wall or pipe mounting.

<b>MODEL 320HP FLOW THROUGH HIGH-PURITY pH SENSOR</b>	
<b>Code</b>	<b>Measuring Electrode (required selection)</b>
10	General Purpose pH
<b>Code</b>	<b>Preamplifier (required selection)</b>
50	Preamp and 3K T.C. for use with Model 1181pH (requires cable PN 9200000)
54	Preamp and Pt100 T.C. for use with Models 1054A/B, 2054, & 2081 (requires cable PN 9200000)
55	No Preamp and Pt100 T.C. for use with Models 54/54e, 1055, 81, 3081, 4081, 5081, Xmt, and SCL-P (requires cable PN 661-646983)
56	Preamp and Pt100 T.C. for use with SCL-P (requires cable PN 661-892884)
57	Preamp and Pt100 T.C. for use with Model 2700 (requires cable PN 661-898695)
58	Preamp and Pt100 T.C. for use with Models 54/54e, 81, 3081, 4081, 5081, and Xmt (requires cable PN 9200273)
<b>320HP</b>	<b>10 50 EXAMPLE</b>

**NOTE:** Interconnecting cable is required. Specify length.

## ACCESSORIES

<b>PART #</b>	<b>DESCRIPTION</b>
2001492	Tag, Stainless Steel, specify marking (Formerly Code -40)
22698-02	Preamplifier, Plug-in, 1181/1050 compatible
22698-03	Preamplifier, Plug-in, 1054/A, 2054, 2081 compatible
23722-00	Pipe/Wall Mounting Bracket (Formerly Code -30)
661-646983	Cable, 4 conductor, 1 coax (for option -55), per ft
661-892884	Cable, 7 conductor (for option -56), per ft
661-898695	Cable, 5 conductor (for option -57), per ft
9200000	Cable, 4 conductor, 20AWG, 1 pair shielded (for option -50 and -54), per ft
9200273	Cable, 11 conductor, shielded, unprepped (for option -58), per ft

## SECTION 2.0 MECHANICAL INSTALLATION

### 2.1 GENERAL

The sensor requires some customer assembly, therefore care should be taken that the instructions are followed carefully to ensure all parts are properly installed.

### 2.2 UNPACKING

Inspect the shipping container. If evidence of damage is noted, contact the carrier. If no damage is evident, open the container and inspect the sensor for damage. Again, if damage is apparent, notify the carrier. Save the shipping container and all packing material. This will help prevent damage during transit should the sensor ever require factory servicing.

### 2.3 PREPARATION FOR INSTALLATION

Prepare the sensor for installation as follows:

1. Remove the reference cell by turning it about ten degrees clockwise and pulling it straight out. Hold the cell in the position shown in Figure 2-1 and remove the solid plug from the reference cell body. Gently break away any salt crust which may have formed around or inside the opening. Top off the reference cell with distilled water, tapping the cell gently to dislodge any air bubbles. Install the liquid junction supplied (PN 2001317). It is not necessary to use thread sealants. Teflon tape may be used if a loose fit is observed. The use of sticky "pipe dope" compounds should be strictly avoided. Use care not to get any greasy materials on the surface of the liquid junction. As the plug is installed, beads of water should appear on the surface of the liquid junction as water is forced through the porous material. If water beads are not present on the junction surface the liquid junction should be replaced (PN 2001317).
2. Lubricate the o-ring on the reference cell using the o-ring lubricant supplied (PN 2001928). Place the reference cell back on the flow cell. Rotate it counterclockwise until the ears seat in the retainer brackets.
3. Install sensor panel so the process flow will enter at the bottom of the cell and exit from the top (Figure 2-2). Make sure that the panel is securely attached to the mounting surface.

**2.3.1 Plumbing.** Plumb the sensor from sample line to discharge. Be careful not to over tighten these connections. Plastic parts can be cracked by excessive force. The distance from the sample line should be as short as possible to minimize lag time in control applications.

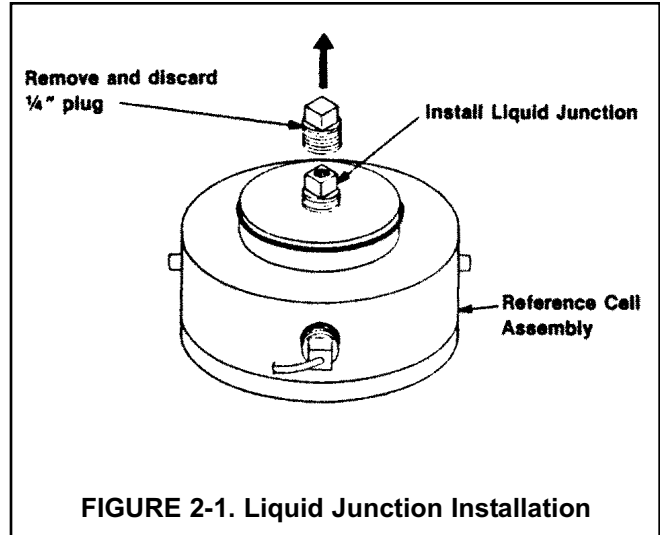


FIGURE 2-1. Liquid Junction Installation

**2.3.2 Electrical Installation.** Figures 2-3 through 2-10 provide the guidelines for wiring the 320HP sensor to the ABS junction box with a built-in preamplifier to various analyzer/transmitter instruments.

Refer to Figure 2-2 and proceed as follows:

1. Make sure the conduit fittings are properly attached to the enclosure junction box.
2. Install the pH electrode into the sensor's flow cell as shown in Figure 2-2.
3. Plug the preamplifier into the junction box.
4. Connect the pH electrode to the preamplifier.
5. Connect the temperature compensator.
6. Ensure that guard wire is connected to the stainless steel flow cell.
7. Make the required connections to the instrument. Use care to dress the wires so they are not exposed and susceptible to shorting or grounding. (Recommended cables are listed on page 2)

#### NOTE

Do not run signal cable next to A.C. lines.

8. Attach the junction box cover, making sure the gasket seal keeps moisture out of the box.

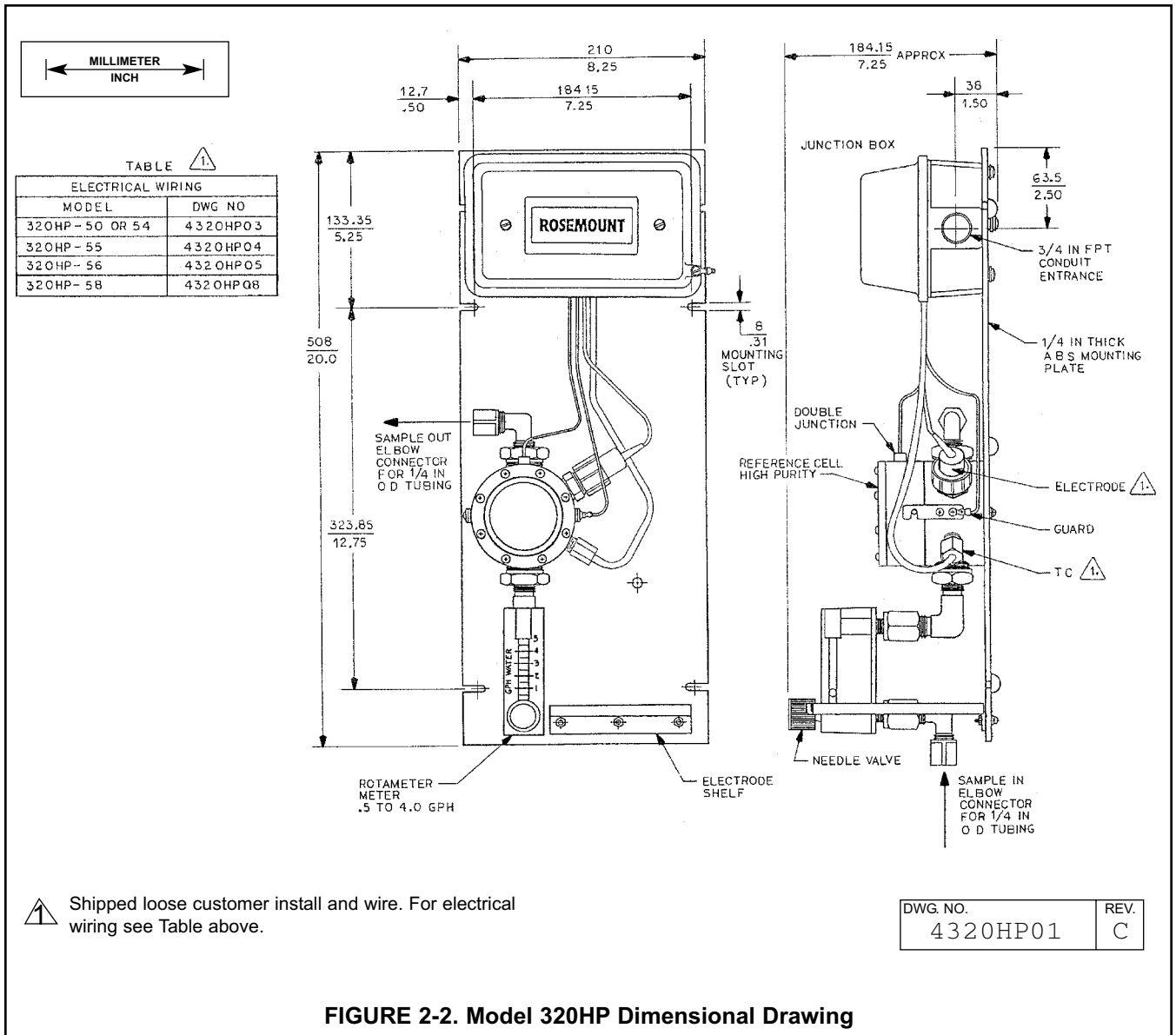


FIGURE 2-2. Model 320HP Dimensional Drawing



### 2.4 INSTALLATION INSPECTION

Prior to operating the sensor and attempting to standardize the instrument, inspect the sensor installation as follows:

1. Verify that the sensor is securely attached to the wall, pipe, or other mounting surface.
2. Check all plumbing connections for leaks. If any are evident, repair them.
3. Check all electrical connections for security. Make sure all wires are properly dressed so they do not short or ground. Make sure the instrument is wired as illustrated in Figure 2-3 through 2-10.
4. If all of the above have been satisfied, proceed to the next section.

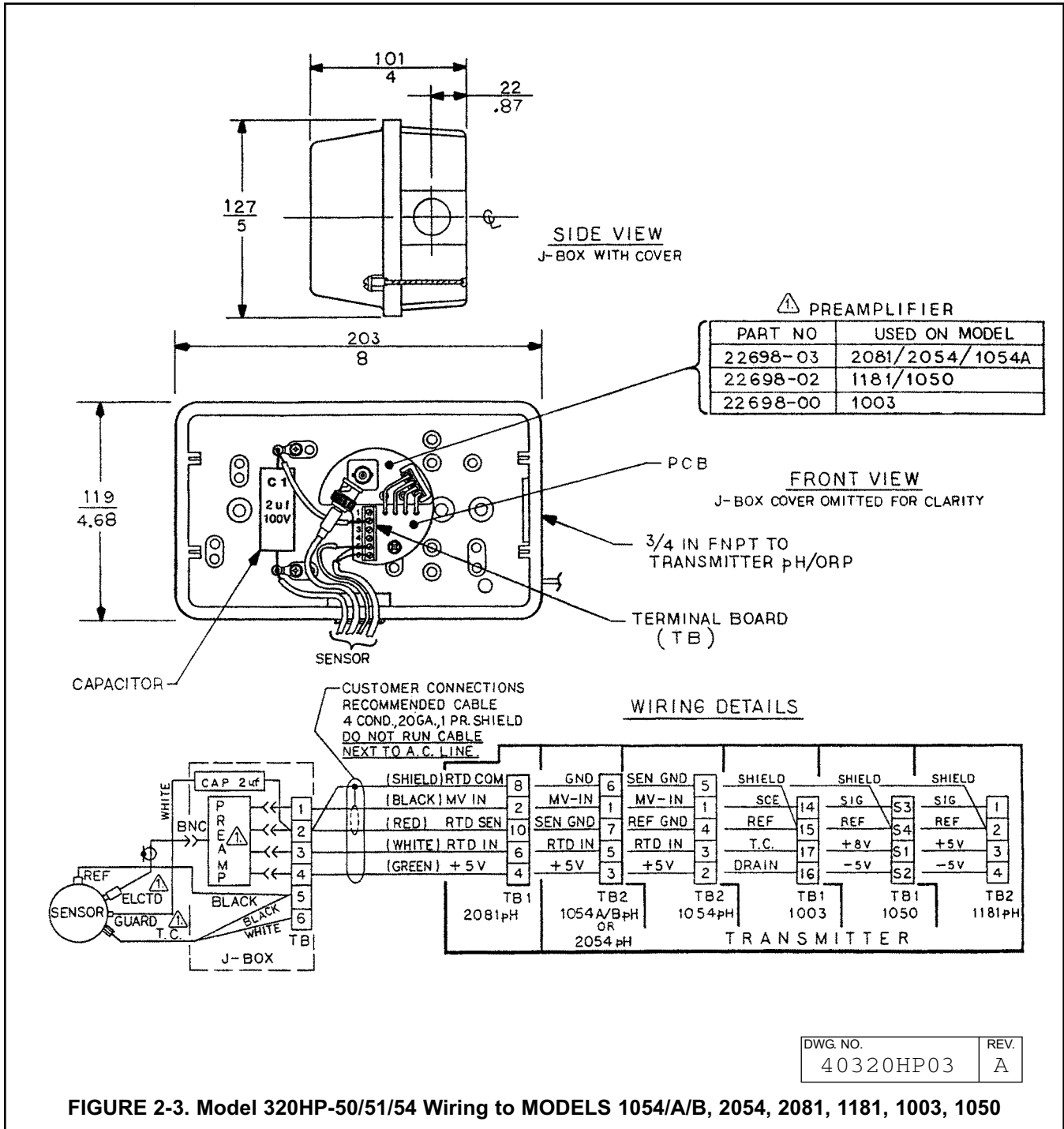


FIGURE 2-3. Model 320HP-50/51/54 Wiring to MODELS 1054/A/B, 2054, 2081, 1181, 1003, 1050

DWG. NO. 40320HP03	REV. A
-----------------------	-----------

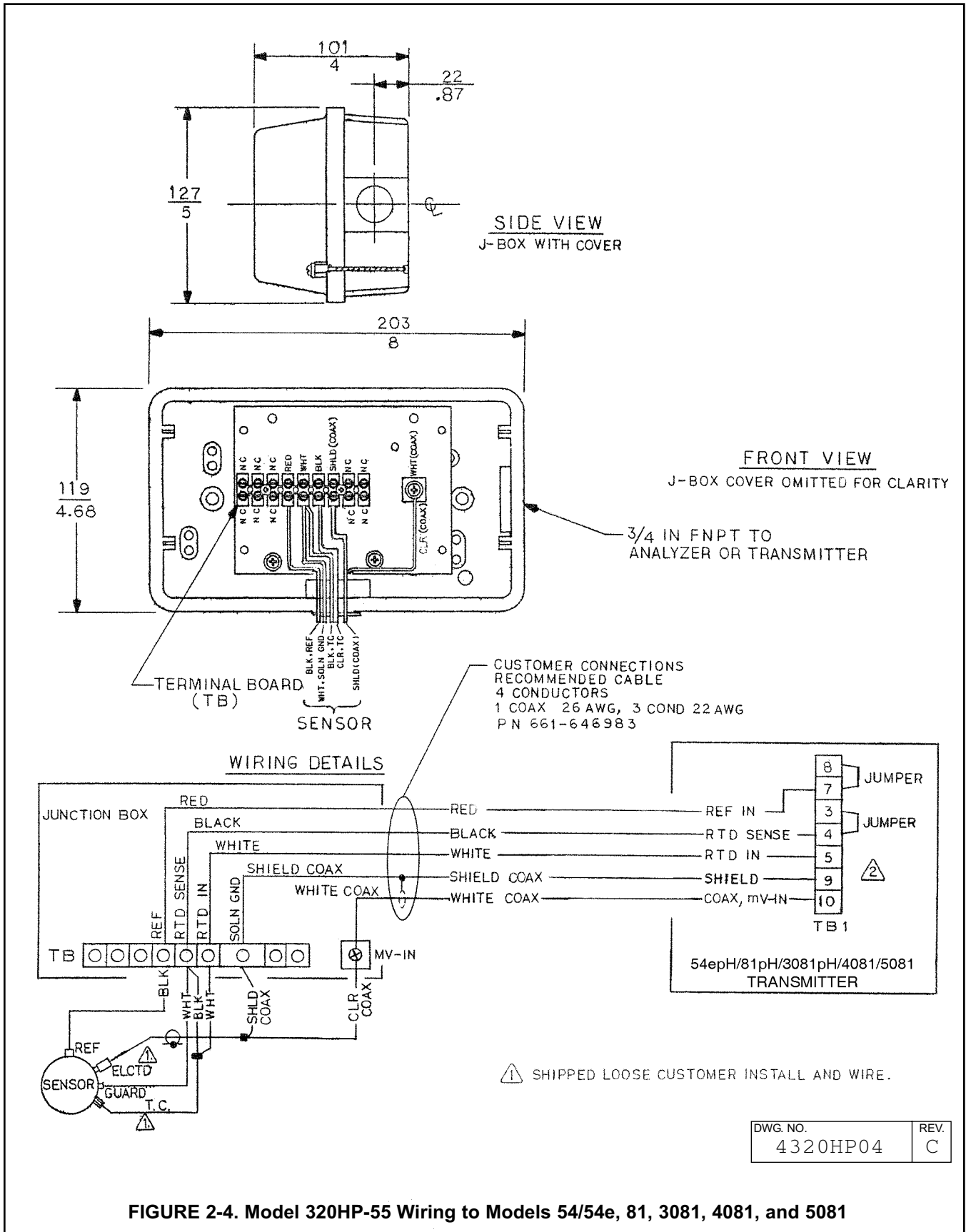
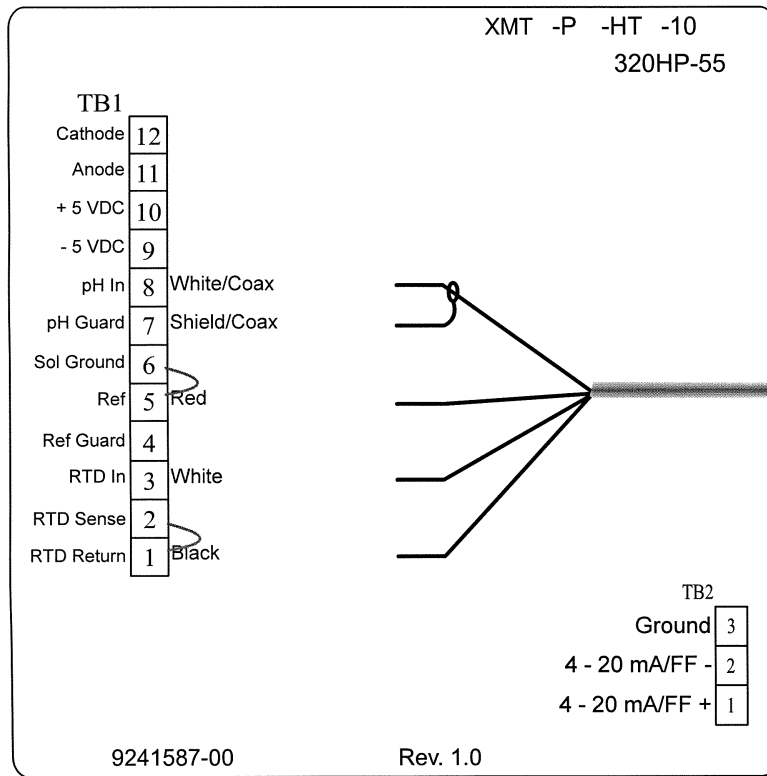
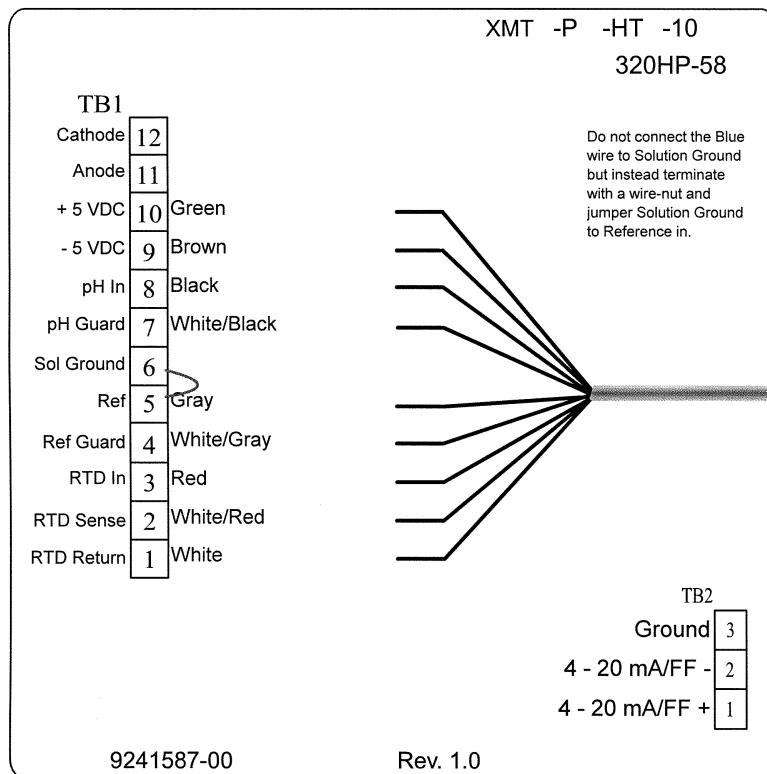


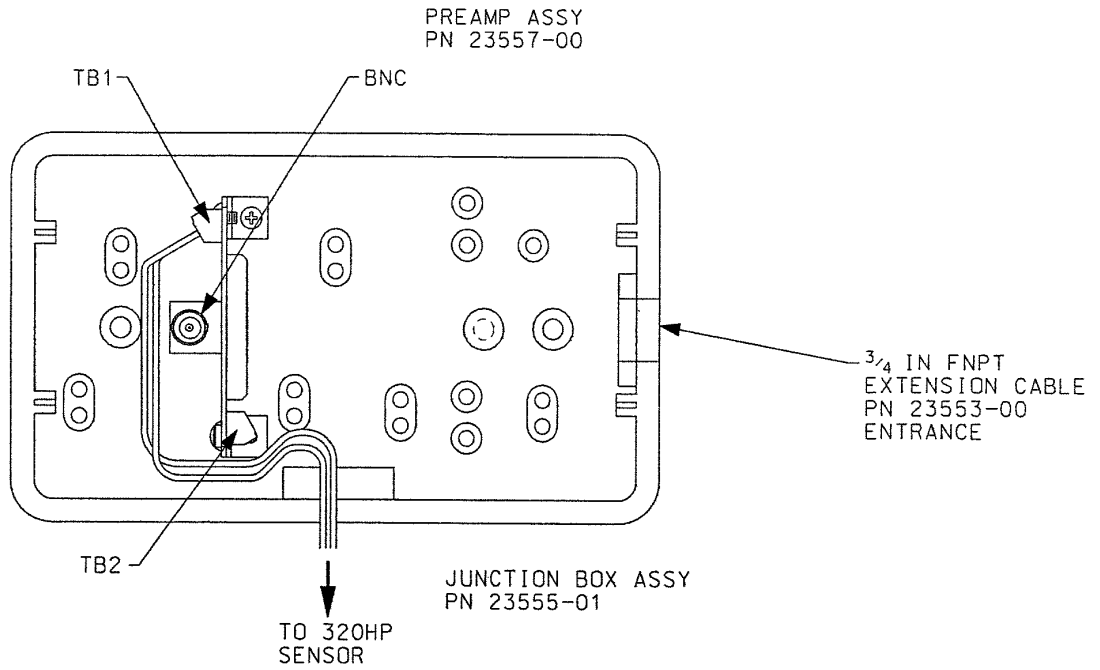
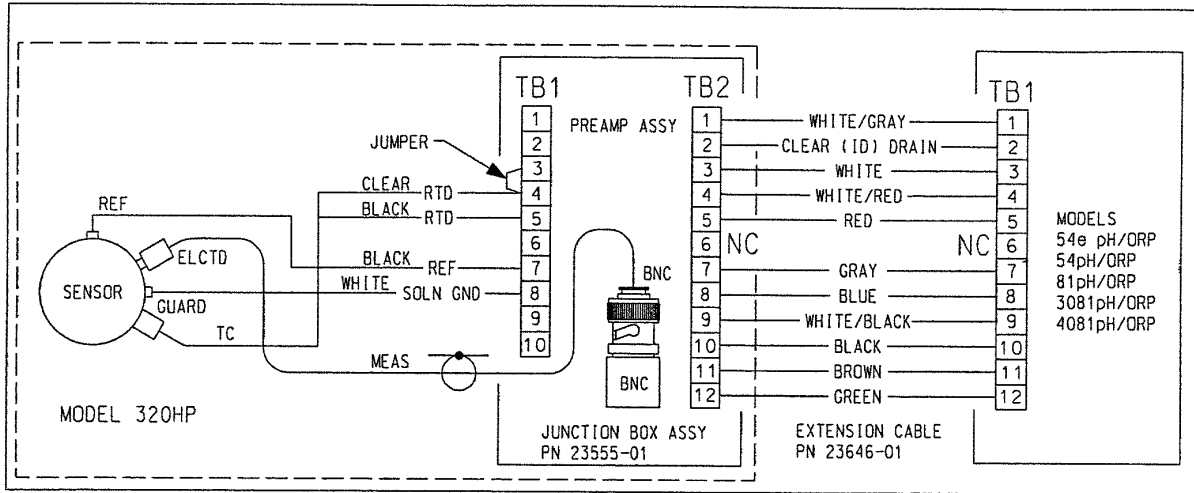
FIGURE 2-4. Model 320HP-55 Wiring to Models 54/54e, 81, 3081, 4081, and 5081



**FIGURE 2-5. Model 320HP-55 Wiring to Xmt-P-HT-10**

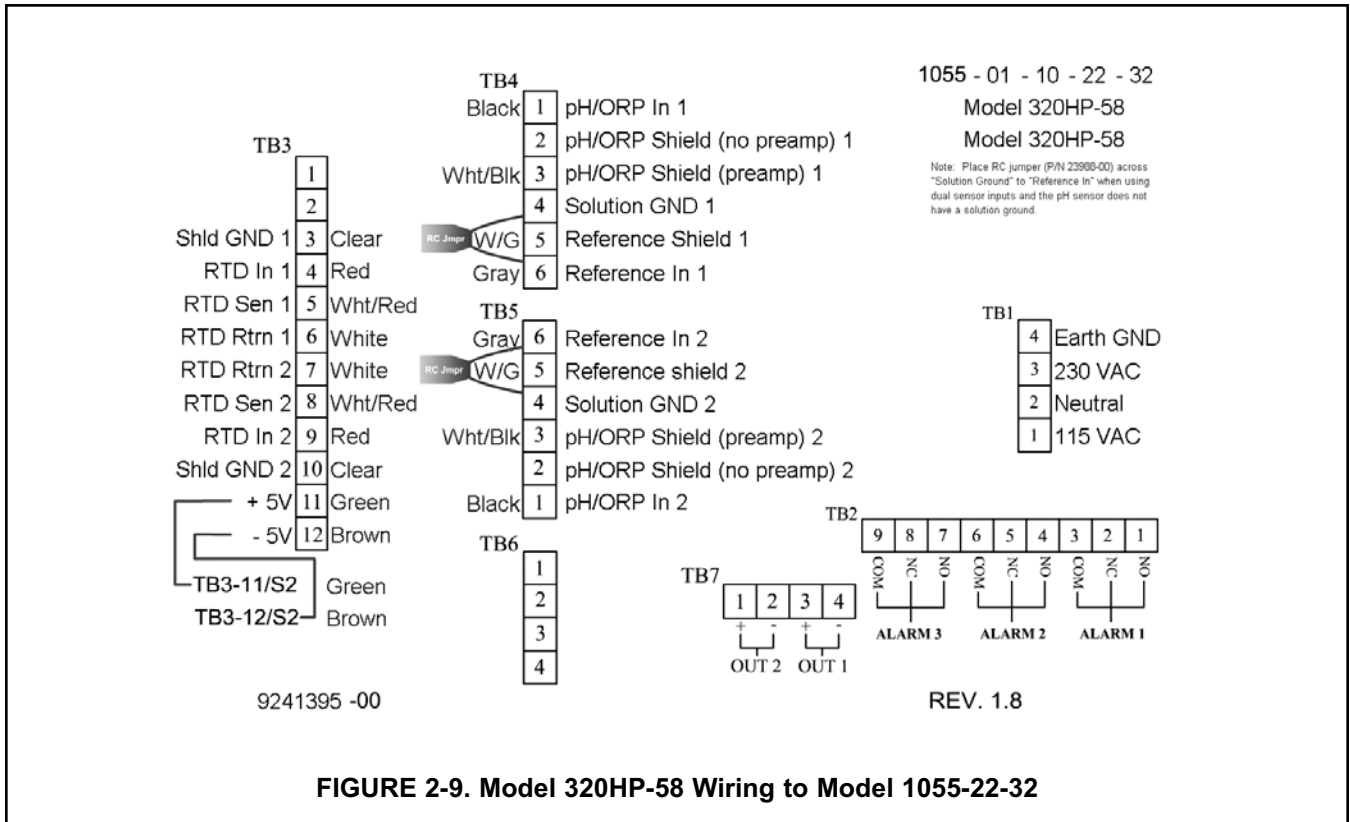
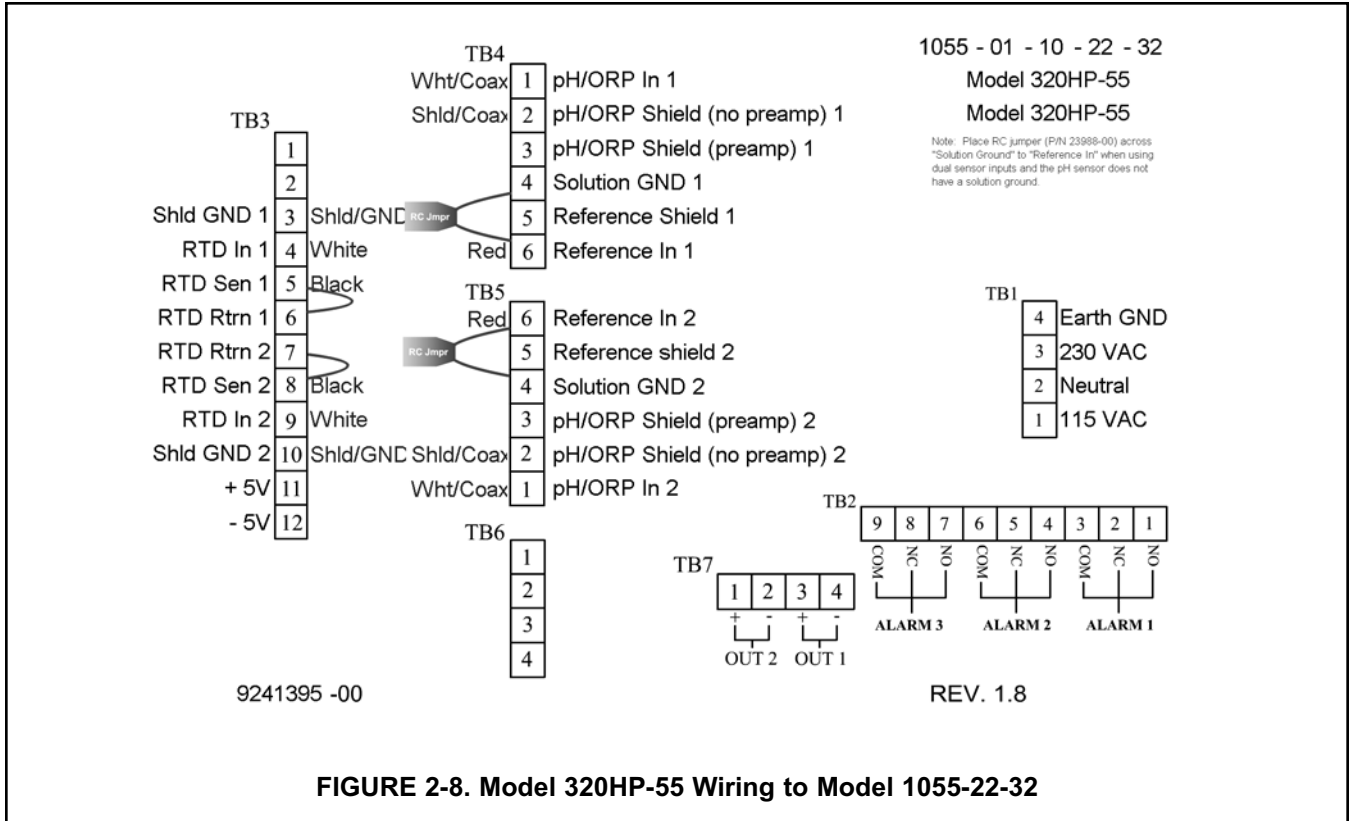


**FIGURE 2-6. Model 320HP-58 Wiring to Xmt-P-HT-10**

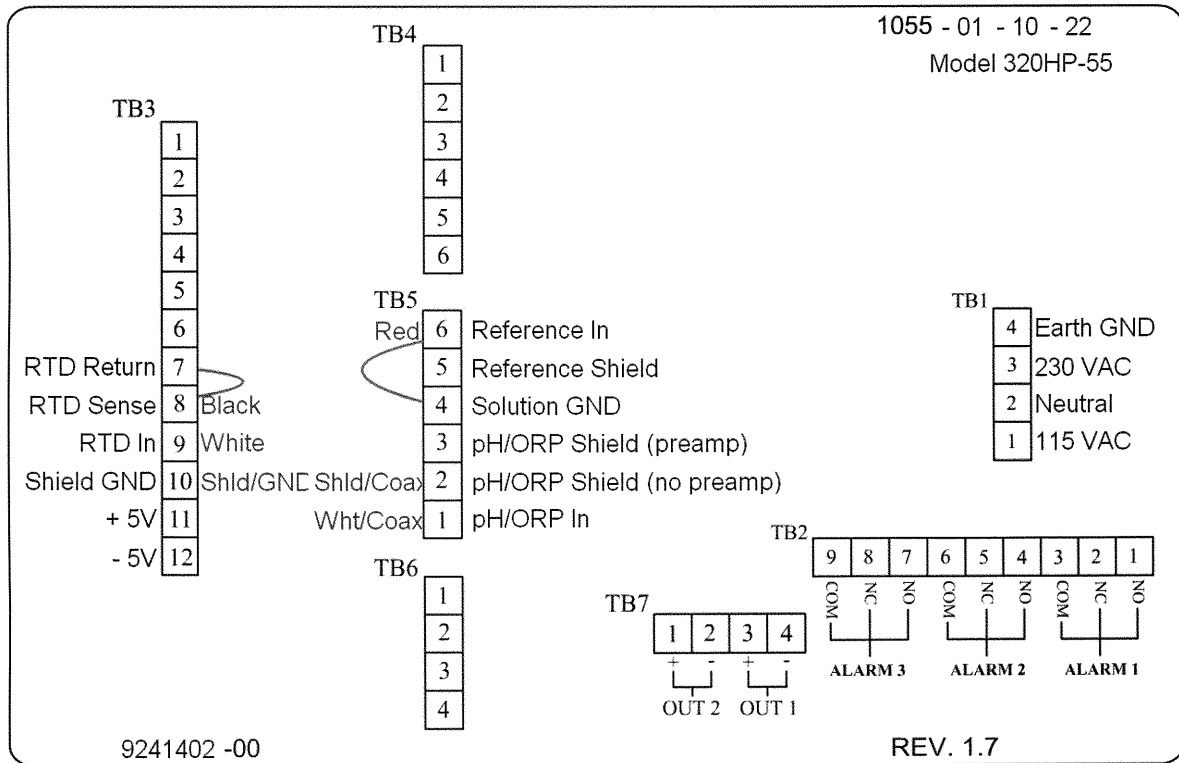


DWG. NO.	REV.
4320HP09	A

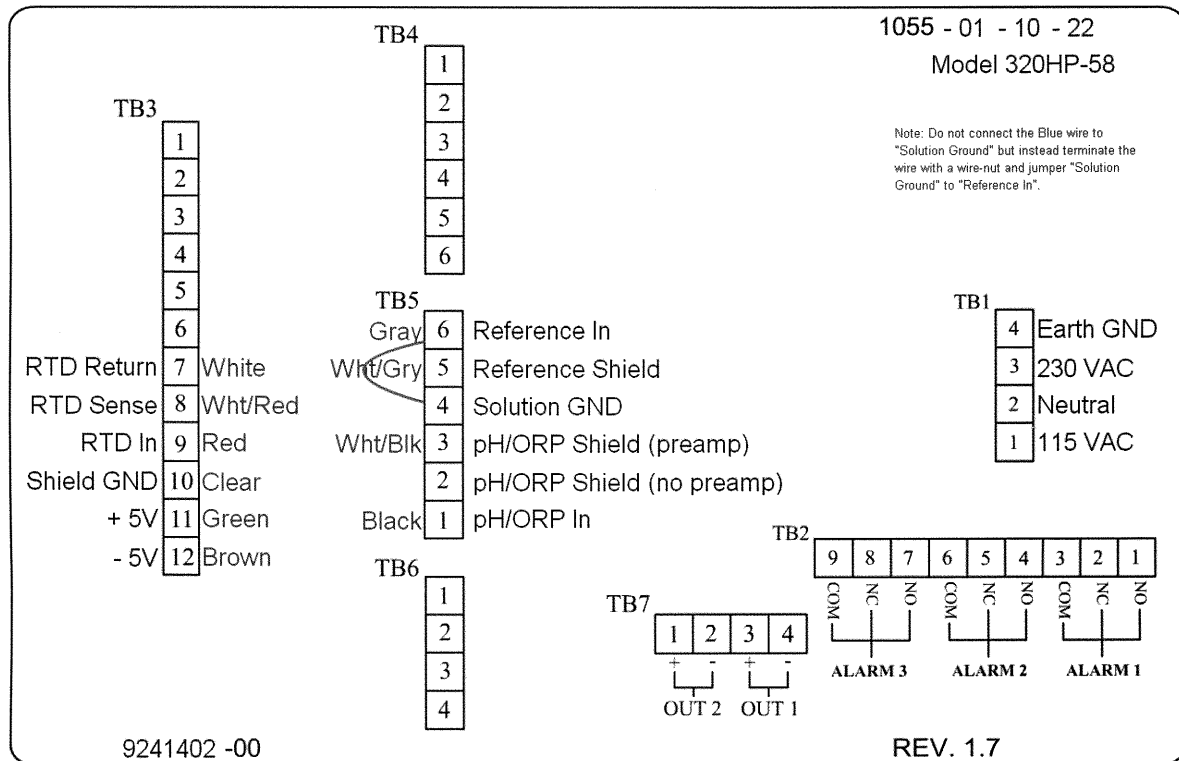
FIGURE 2-7. Model 320HP-58 Wiring to Models 54e, 81, 3081, 4081, and 5081



**MODEL 320HP-55**



**MODEL 320HP-58**



**FIGURE 2-10. Model 320HP Wiring to Model 1055 Pipe/Wall Mount**

## SECTION 3.0 OPERATION

### 3.1 GENERAL

This section contains adjustment, standardization, and set-up instructions to put the sensor in operation. The sensor is completely automatic and may require only an occasional electrode cleaning and reference electrolyte replenishment. See Maintenance, Section 4.0 for instructions.

### 3.2 START-UP CALIBRATION PROCEDURE

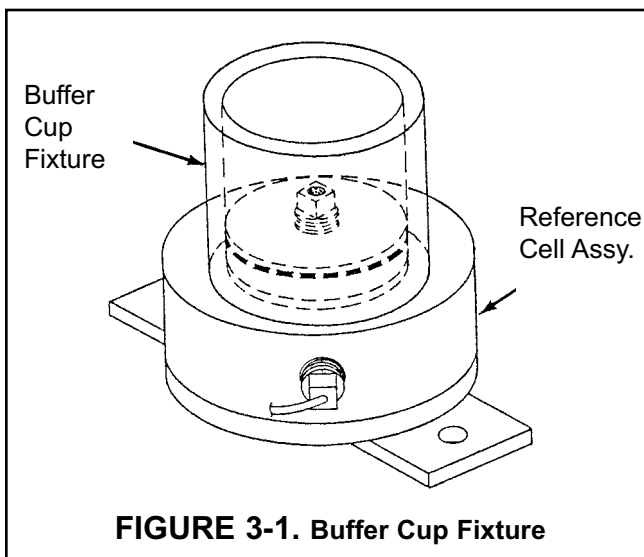
#### 3.2.1 Buffer Calibration Method

1. Ensure that the following items are available for buffer calibration:
  - A. Buffer solutions 4, 7 and 10 pH.
  - B. Buffer cup fixture (Figure 3-1).
  - C. Buffer calibration liquid junction.
2. Insure there is no process flow through stainless steel flow cell if Model 320HP is installed. Remove reference cell from flow cell and install the buffer calibration liquid junction in place of the high purity foam junction or shipping plug.

#### NOTE

If the high purity foam junction is contaminated with buffer, a pH offset will occur.

3. Install the buffer cup fixture onto the reference cell as shown in Figure 3-1. Place the glass end of the glass electrode into the buffer cup and connect the glass electrode connector to the preamp connector (BNC).
4. Insure pH analyzer is wired properly to the Model 320HP Sensor. Fill the buffer cup fixture half full with 7 pH buffer then apply power to the pH analyzer and allow 10 minutes for stabilization of the analyzer reading.



#### NOTE

For the following calibration steps refer to the analyzer manual for adjustments of standardize, span or efficiency.

5. After the analyzer reading has stabilized, standardize the analyzer to a 7 pH reading. Allow 5 minutes operation to verify stability. Re-adjust standardization if necessary.
6. Remove the 7 pH buffer from the cup fixture and rinse with clean potable water.
7. Fill buffer cup half full with 4 pH buffer and allow 5 minutes for stabilization of the pH reading. Adjust the analyzer's span of operation for a 4 pH reading.
8. Remove the 4 pH buffer and rinse thoroughly with potable water. Fill the buffer cup fixture half full with 10 pH buffer and allow 5 minutes for stabilization. Verify the pH reading is 10 pH  $\pm$  0.1 pH.

#### NOTE

If the 10 pH reading is outside of the aforementioned tolerance verify the temperature compensator is stable at a constant ohmic value and recalibrate by repeating Steps 5 through 8.

9. Remove 10 pH buffer from the buffer cup fixture and rinse with potable water. Remove the buffer cup fixture from the reference cell. Remove power from the analyzer.
10. Remove glass electrode connector from the preamplifier connector (BNC). Install the glass electrode into stainless steel flow cell and reinstall the electrode connector to the preamplifier's BNC.
11. Remove the buffer calibration liquid junction from the reference cell and install the high purity foam junction. Install the reference cell to the flow cell (see Section 2.3).
12. Complete sensor installation if not already done. Refer to the sensor installation procedure of this manual.

#### 3.2.2 On Stream Sensor Calibration Method.

1. Place the sensor on stream. Adjust rotometer to the proper flow rate (see Figure 2-2). Allow 2 to 3 hours for full sensor stabilization.
2. When the reading is stable, note its value and immediately obtain a sample of the solution, near the sensor. Insure that the sample is sealed from the atmosphere to avoid changes to the pH value.
3. Check the above sample on a bench meter. Standardize the analyzer as necessary to obtain agreement with the bench meter. Take more than one sample to assure maximum accuracy.

## SECTION 4.0

# MAINTENANCE AND TROUBLESHOOTING

### 4.1 GENERAL

This section contains the scheduled preventative maintenance and troubleshooting for the sensor. The intent of this section is to furnish the user with the information necessary to maintain his own equipment by providing a maintenance schedule and troubleshooting guide.

### 4.2 SCHEDULED PREVENTATIVE MAINTENANCE

Regular scheduled maintenance of the sensor should be performed to keep the sensor in good operating condition. The time periods shown may need to be varied according to the user's particular operating conditions.

#### 4.2.1 Maintenance Every 30 Days.

##### NOTE

Make sure the sample line has been shut off from the system prior to removing the electrode or reference cover.

##### A. Electrode Cleaning.

1. Shut off the sample flow and drain the flow cell to remove the hydrostatic seal.
2. Remove the electrode assembly by unscrewing the electrode housing gland nut and pulling the electrode straight out. Clean the electrode with a soft lint-free cloth or tissue. If this does not remove all accumulated deposits, wash the electrode in a 5% hydrochloric acid solution and then rinse with water.
3. Check the o-ring for deterioration or deformation and replace if necessary.
4. Before reinstalling the electrode, apply o-ring lubricant (PN 2001928) to the o-ring. Care must be taken to prevent lubricant from contacting the measuring tip as this will interfere with the sensor's operation.
5. Position the o-ring on the gland fitting and insert the electrode (with washer and gland nut) into the gland. Tighten the gland nut. Do not use tools.

##### B. Reference Cell.

1. Check the level of the salts by looking through the clear window on the back of the reference cell. If less than 1/2 of the cell has a crystalline structure (or if the electrolyte is completely clear), the reference cell needs recharging.
2. If the reference needs recharging, turn the reference cell to unlock it from the bracket, then pull straight out. Remove the junction.

3. Empty the electrolyte from the reference cell and flush it with deionized water.
4. Place the reference cell on a flat surface, window side down. Add deionized water to half fill the cell. Slowly add new crystals (PN 9210243) until approximately 90% full. Top off with deionized water, insuring that no air is entrapped.
5. Replace the foam junction. Use o-ring lubricant (PN 2001928) on the reference cell's process o-ring and position the reference cell onto the flow cell.
6. Secure the reference cell to the flow cell by turning the cell until it is locked in place to the flow cells brackets.
7. Calibrate the sensor and analyzer as described in Section 3.2.

#### 4.2.2 Maintenance Every Year.

##### NOTE

Make sure the stream line has been cut off from the system prior to removing the electrode or reference cover.

**A. Electrode Cleaning.** Refer to Section 4.2.1, A for instructions.

##### B. Reference Cell.

1. Remove the reference cell from the flow cell by unlocking it from the bracket and pulling the cell straight out.
2. Remove the liquid junction and the microjunction. Remove the eight screws that hold the reference cell cover in place. Separate the cover from the reference cell body.
3. Discard all liquid or slurry material from the reference cell. Thoroughly clean the reference cell body and cover. Hot water may be used to remove any caked on salts.
4. Carefully remove both o-rings from the reference cell assembly. Clean the grooves of any foreign material and salts. Carefully inspect the o-rings for nicks, cracks or flatness and replace if needed (see Figures 5-1 and 5-2 for part number).
5. Dry the grooves and install the o-rings, lightly coated with o-ring lubricate (PN 2001928).
6. Install a new-microjunction (PN 22994-00 ). Recharge the flow cell as described in Section 4.2.1.
7. Install a new liquid junction (PN 2001317). Do not use pipe dope or thread sealant. If required, Teflon tape may be used to provide a tighter fit.
8. Calibrate the sensor and analyzer as described in Section 3.2.



**4.2.3 Electrode Maintenance.**

The glass electrode has a limited process life dependent on process conditions. It is our recommendation that the electrode be checked and replaced as required to insure the proper operation of the system. Test per Figure 4.3

**4.3 TROUBLESHOOTING**

**4.3.1 Without Advanced Diagnostics.**

In the event of a malfunction, refer to Table 4-1 below. This is intended as a guide and lists the troubles in order of probable frequency of occurrence. Do not be misled by the troubles; always look for the cause before trying the remedy.

**TABLE 4-1. Troubleshooting Without Advanced Diagnostics**

TROUBLE	CAUSE	REMEDY
a. Meter reads off scale.	Defective preamplifier.	Check preamplifier as instructed in Section 4.4.2 and replace if defective.
	Temperature compensator shorted, with solution below 7.0 pH (in AUTO T.C. mode).	Check T.C. resistance (see section 4.4.6).
	Reference and drain leads shorted, (mis-wired) (Model 1002, 1003 only).	Correct wiring.
	Broken glass electrode.	Replace glass electrode.
	Plugged liquid junction.	Replace liquid junction.
	Drain and source leads between preamp and analyzer open (broken wires) (Model 1002, 1003 only).	Correct wiring.
	Broken reference electrode.	Replace electrode and recharge ref. cell.
	Glass or reference lead open.	Repair wiring; check for coated or plugged liquid junction.
b. Meter reads center scale (7 pH or 0 mV) only, will not move or only a small distance ( $\pm 1$ pH for Model 320B).	Source and reference leads shorted (mis-wired).	Repair wiring.
	T.C. open or disconnected AUTO T.C. mode.	Check T.C. per Section 4.4.5.
	Badly coated or internally damaged (cracked) glass electrode.	Clean or replace electrode.
c. Indication is stable between 3 and 6 pH, regardless of actual sample pH.	Glass electrode cracked.	Replace glass electrode.

**NOTE**

In a system with a **stable** preamplifier, many troubles listed under CAUSE **may** cause the meter to swing **either** way, depending on the electrical noise environment.

**TABLE 4-1. Continued  
(Troubleshooting )**

TROUBLE	CAUSE	REMEDY
d. Span between buffers extremely short in auto T.C. mode.	Temperature compensator open.	Check T.C. resistance (see Section 4.5.5).
	Foam junction in space.	Use wood junction for buffer cal.
e. Meter indication swings widely (may swing full scale) in AUTO T.C. mode.	Temperature compensator shorted.	Check T.C. resistance (see Section 4.4.5).
f. Sluggish, slow indication on meter for real change in pH.	Glass electrode coated.	Clean electrode as instructed in section 4.2.1.
f. Electrode cannot be standardized (STANDARDIZE control in transmitter at end of rotation).	Glass electrode cracked or coated.	Replace electrode.
	Reference electrode contaminated.	Recharge and inspect per Section 4.2.1 thru 4.2.2.
	Defective preamplifier.	Check preamplifier as instructed in Section 4.4.1 and replace if defective.
	Bias control in analyzer improperly set or mistakenly adjusted. (Model 1002,1003 only).	Consult analyzer manual.

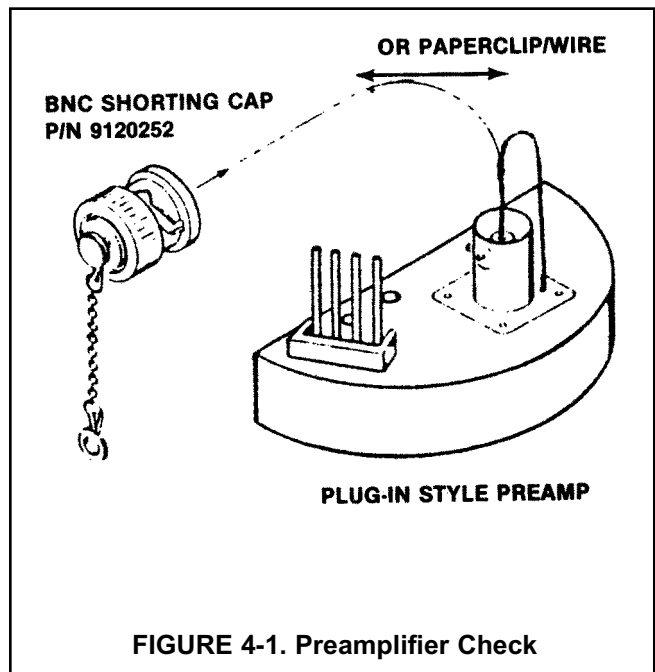
**4.4 MAINTENANCE**

This section consists of replacing defective parts and making necessary checks to determine if the sensor is operational. The following determines if the part being checked is operable and should be used in conjunction with the Troubleshooting Table.

**4.4.1 Preamplifier Check.**

To determine if the preamplifier is operable, proceed as follows:

1. Using a BNC Shorting Cap (refer to Figure 4-1) or a paper clip, short the preamplifier connection
2. Follow analyzer instruction manual for standardization procedure. The meter should be able to be made to read 7.0 pH.
3. If the meter/display can not be made to read 7.0 pH, replace the old preamplifier with a new one and perform the check again.



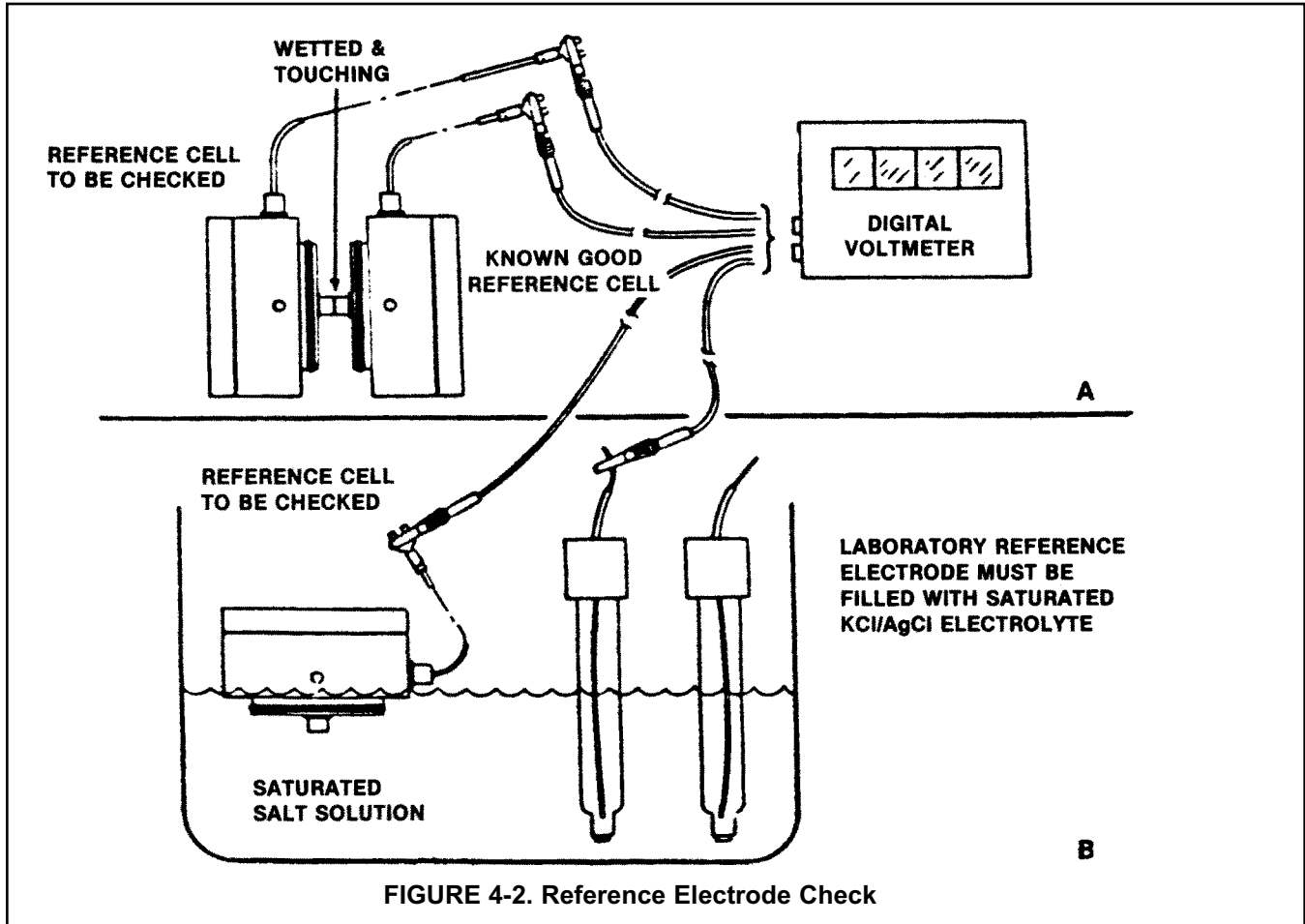
**4.3.2 Troubleshooting with Advanced Diagnostics.**

The Model 54/54e analyzers and Model 81, 3081, 4081, and 5081 transmitters automatically search for fault conditions that would cause an error in the measured pH value, as does the Model 1054A pH/ORP analyzer to a lesser degree. Refer to the applicable Instruction Manual for a complete description of the analyzer’s fault conditions.

Table 4-2 lists the diagnostic messages that indicate a possible sensor problem. A more complete description of the problem and a suggested remedy corresponding to each message is also listed.

**Table 4-2. Troubleshooting with Advanced Diagnostics**

<b>DIAGNOSTIC MESSAGE</b> 54/54e 81/3081/4081/5081	<b>DESCRIPTION OF PROBLEM</b>	<b>REMEDY</b>
“Calibration Warning” A2U9. 2 c	1. Aged glass. 2. Sensor not immersed.	1. Perform buffer calibration. 2. Be sure electrode measuring tip is in process.
“Cracked glass failure” MUESS 29J	Broken or cracked glass.	Replace sensor.
“Input voltage high” “Input voltage low”	pH input shorted or sensor miswired.	Check wiring. Replace sensor if necessary.
“Old glass warning” MUOSS W2	1. Glass electrode worn out. 2. Sensor not immersed.	1. Replace sensor. 2. Be sure electrode measuring tip is in process.
“Reference offset err” (offline only) S c	Reference electrode poisoned.	Replace sensor.
“Ref voltage high” “Ref voltage low”	1. Reference shorted or sensor miswired. 2. Sensor not immersed	Check wiring. Replace sensor if necessary.
“Sensor line open” UB c dAB	1. Open wire between sensor and analyzer. 2. Interconnecting cable greater than 1000 ft.	1. Check sensor wiring. 2. Relocate analyzer.
“Sensor miswired”	1. Open wire between sensor and analyzer. 2. Bad preamplifier.	1. Check wiring. 2. Replace preamplifier. (Code 02 only)
“Temp error high” “Temp error low” cMo F9 cMo d7	1. Open or shorted RTD. 2. Temperature out of range.	1. Replace sensor. 2. Check process temperature.

**NOTE**

The Rosemount Analytical Model 213 Millivolt Test Box provides a complete electrical simulation of any pH value, giving virtually 100% assurance that the preamplifier and analyzer are operating properly.

**4.4.2 Reference Electrode Check.** There are two methods which can be used to check the reference cell; one requires the use of a known good reference cell and digital voltmeter and the other, the use of a laboratory reference electrode filled with a saturated KCl/AgCl electrolyte. Proceed as follows:

1. Using a known good reference cell (P/N 22984-01 or 2001852), and a digital voltmeter, set up as shown in Figure 4-2 (A).
2. Wet the liquid junction on both reference cells and touch them together at the flat surface of the liquid junctions (make sure there is direct contact and the surfaces are wet).
3. Meter should indicate less than 10 millivolts.
4. If meter does not indicate less than 10 millivolts, repair the reference cell as instructed in Section 4.2.1.B.

To check the cell using a laboratory reference electrode proceed as follows:

1. Make sure the laboratory reference electrode is filled with a saturated KCl/AgCl electrolyte.
2. Place the reference cell and the laboratory reference electrode in a beaker filled with a saturated salt solution as shown in Figure 4-2 (B) or use buffer cup provided with sensor.
3. Meter should indicate less than 10 millivolts.
4. If meter does not indicate less than 10 millivolts, repair the reference cell as instructed in Section 4.2.1.B.

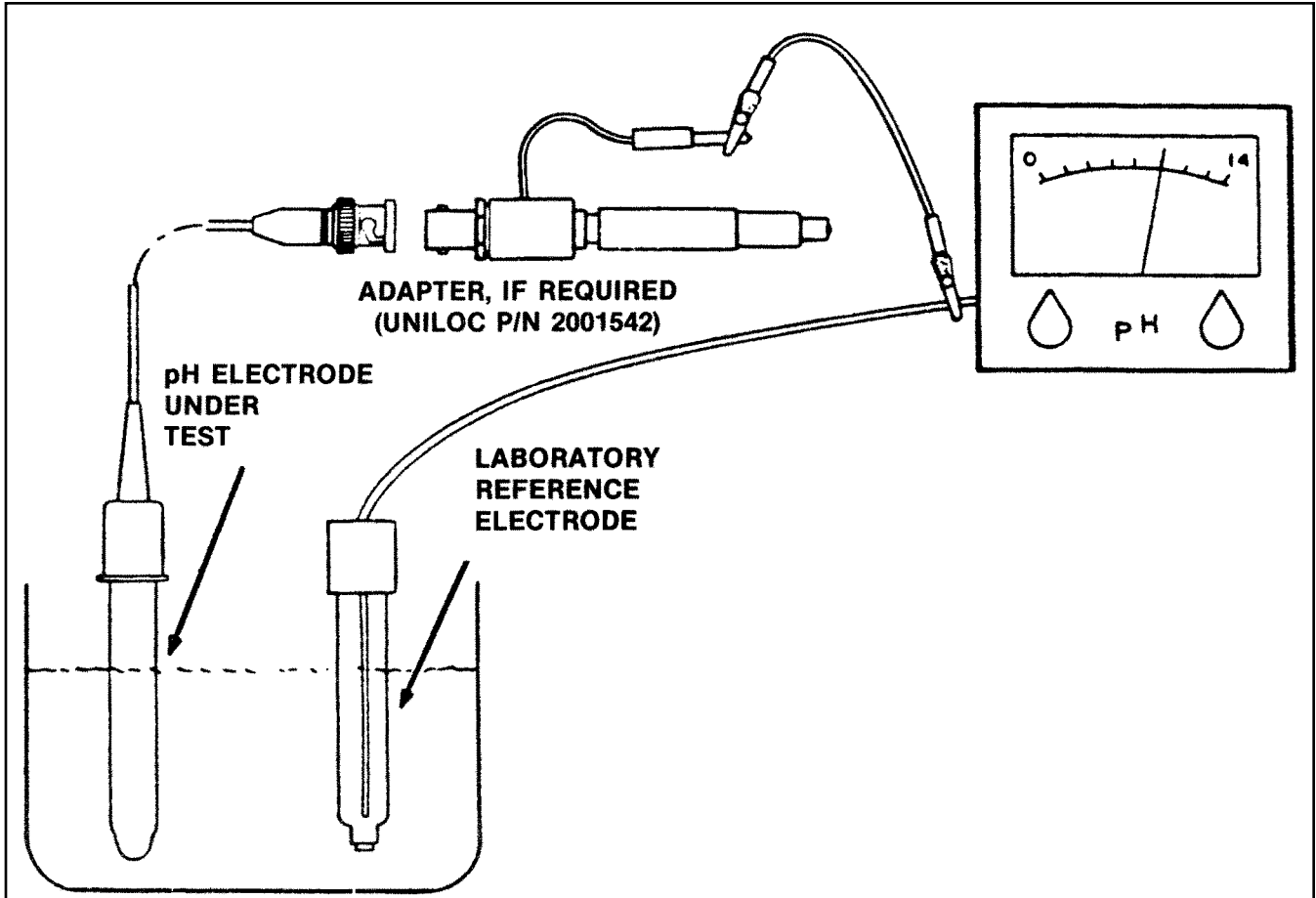


FIGURE 4-3. Glass Electrode Test Method

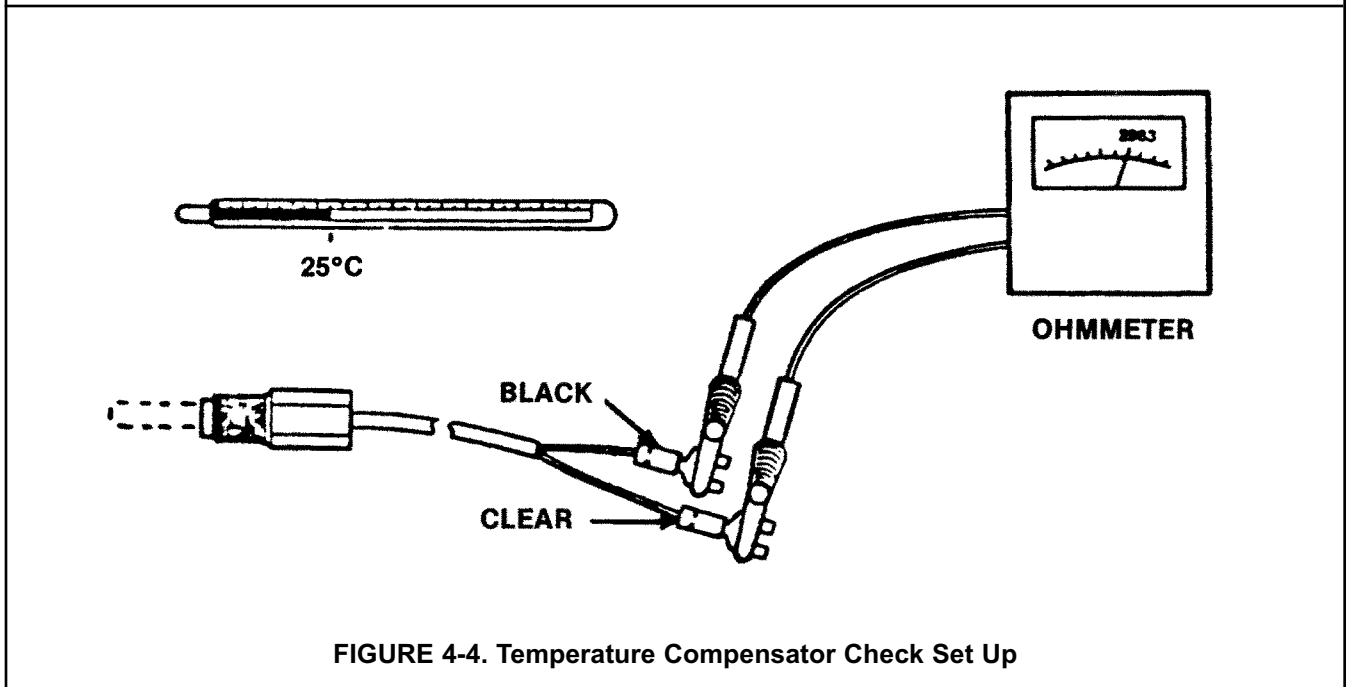


FIGURE 4-4. Temperature Compensator Check Set Up

**4.4.3. Glass Electrode Check.**

The glass electrode may be checked as follows: Refer to Figure 4-3.

Failure to connect the glass electrode shield to the reference lead as shown will make the reading very noise sensitive, but this will probably not interfere with the basic test. Bad glass electrodes show limited response, or no response at all; they seldom become noisy. A steady reading of 3 to 6 pH regardless of the buffer solution used indicates a cracked glass electrode bulb. A steady reading near 7.0 pH can be caused by a coated or internally shorted pH electrode, connector or cable.

1. Glass electrodes can sometimes be rejuvenated by washing in strong detergent and then a 10 to 20% HCl solution. If the sample stream contains large percentages of non-aqueous liquids, such as alcohols, glass dehydration may occur, but recovery will be rapid in a buffer solution.
2. If the electrode is worn out, response will be unalterably slow and short of span. It must be replaced in this case.

**4.4.4 Liquid Junction.**

This plug must remain porous. To check it out, remove the plug and top off the reference cell to the brim with deionized water. Dry the plug and screw it back into the cell while watching the tip. DO NOT use thread sealants other than TEFLON tape on the threads of the plug. Water beads should be forced through the foam, not just around the edges or threads. If it looks clogged, replace it.

**4.4.5 Automatic Temperature Compensator.**

The temperature compensator element is temperature sensitive and can be checked with an ohmmeter. Resistance increases with temperature.

The 3K element will read 3000 ohms ± 1% at 25°C (77°F) and a Pt-100 will read 110 ohms. Resistance varies with temperature for a 3K and Pt-100 element and can be determined according to Table 4-3 or the following formula:

$$R_T = R_0 [1 + R_1 (T - 20)]$$

Where  $R_T$  = Resistance

T = Temperature in °C

Refer to Table 4-4 for  $R_0$  and  $R_1$  values.

**TABLE 4-3  
TEMPERATURE vs RESISTANCE OF AUTO  
T.C. ELEMENT**

Temperature °C	Resistance (Ohms) ± 1%	
	3K	PT-100
0	2670	100.0
10	2802	103.8
20	2934	107.7
25	3000	109.6
30	3066	111.5
40	3198	115.4
50	3330	119.2
60	3462	123.1
70	3594	126.9
80	3726	130.8
90	3858	134.6
100	3990	138.5

**TABLE 4-4  
 $R_0$  and  $R_1$  VALUES FOR TEMPERATURE  
COMPENSATION ELEMENTS**

Temperature Compensation Element	$R_0$	$R_1$
3K	2934	.0045
PT-100	107.7	.00385

## SECTION 5.0

### PARTS LIST

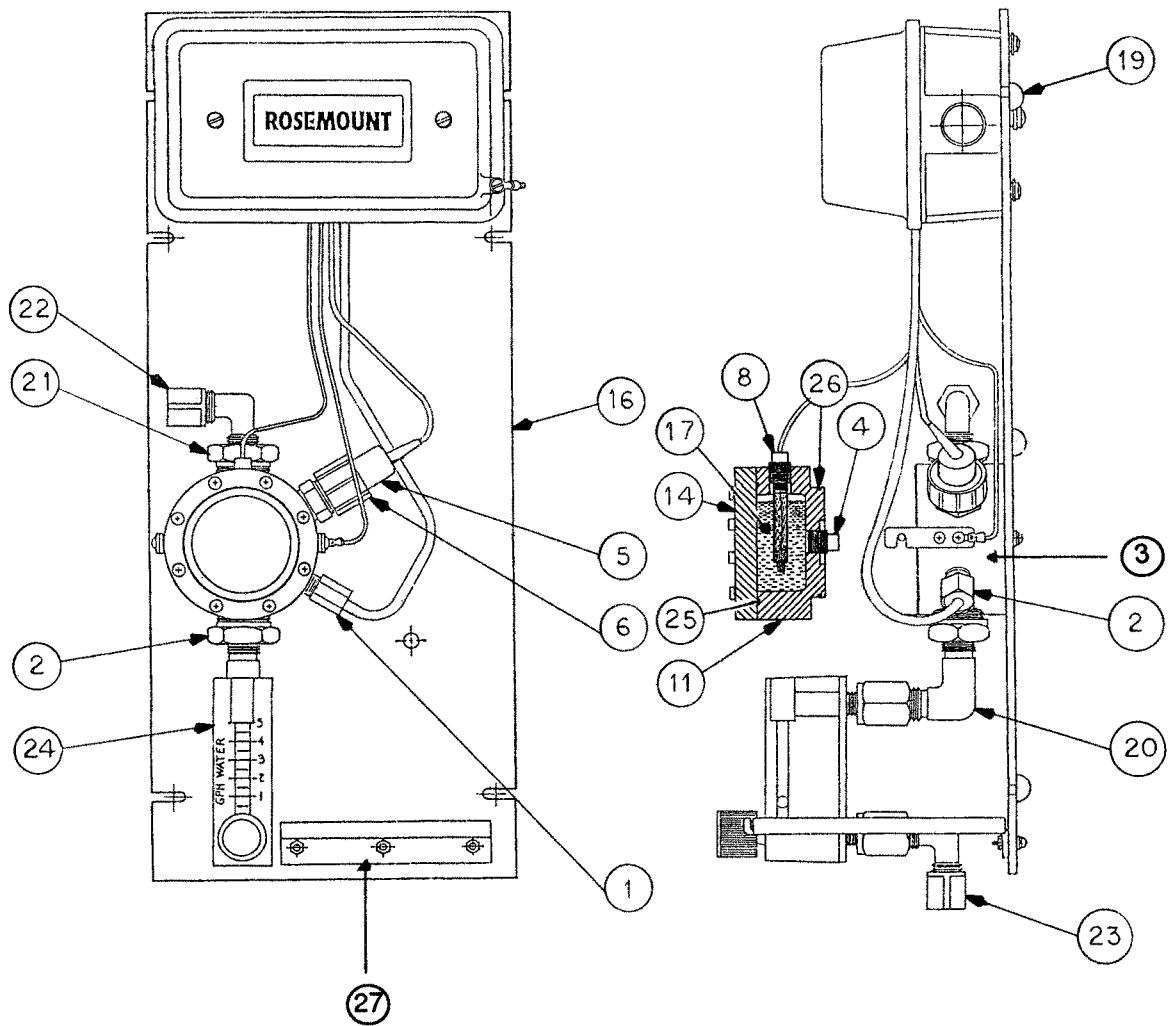
#### 5.1 GENERAL

This section provides illustrations and listings of replacement parts for the Model 320HP Sensor. The illustrations and listings are coded with item numbers to aid in locating parts. If you are looking for a part number, look at the drawing of the assembly which contains that part and follow the arrow leading from that part to the item number. Then look for that item number on the parts list. This will give you the part number, description and quantity recommended for spares of that part. Some parts of the assembly are not listed in the parts list. These parts are not normally furnished as replacement parts.

**TABLE 5-1. Parts List For Model 320HP**  
References Figure 5-1

Item No.	Replacement Part No.	Description	Qty.
1	23132-00	Temperature Sensor, 3K	1
	23132-01	Temperature Sensor, PT 100	1
	2000734	Liquid Junction, Wood/KYNAR for Calibration	1
2	2001312	1/4 in. FNPT-1 in. MNPT Adapter	1
3	2001315	Stainless Steel Flow Cell	1
4	2001317	Liquid Junction, Wood/Foam, KYNAR	1
5	2001553	Glass Electrode w/BNC (options 50/54)	1
5	23642-00	Glass Electrode wo /BNC (options 55/56/57)	1
6	2001779	Housing for pH Electrode	1
	23722-00	Pipe mounting assembly (optional)	1
8	22994-00	Micro-junction Reference Element	1
	23557-00	Preamplifier for use with Models 54/54e, 3081, 4081, 5081, & Xmt	1
	22698-02	Preamplifier for use with Models 1181 pH and 1050	1
	22698-03	Preamplifier for use with Models 1054/2054 Series	1
11	22814-00	PCB Preamplifier mounting (options 50/54)	
	3000793	Reference cell housing, Kynar	1
	3001379	Gasket for J-box*	1
	3001492	J-box base*	
14	3001495	Reference cell polycarbonate cover	1
	3001873	J-box cover*	
16	433-762963	Mounting plate, ABS	
17	9210243	Potassium Chloride (KCl), crystals	2
	9000005	2uf capacitor (options 50/54)	1
19	9160203	Adhesive bumper	4
20	9300073	1-4 in. MNPT stainless steel elbow	1
21	9310059	1 in. MNPT x 1-4 in. FNPT 304 stainless steel bushing	1
22	9321003	1-4 in. MNPT x 1-4 in. tube connector	1
23	9321004	1-4 in. MNPT x 1-4 in. tube elbow	1
24	9390004	Rotameter	1
25	9550010	O-ring, 2-038 BUNA-N	1
26	9550041	O-ring, 2-226 BUNA-N	1
	2001853	Reference cell complete, High Purity	1
27	2002032	Buffer cup	1
	433-762671	Buffer shelf	1

\* For option 50, 54, 55, 56 only.



DWG. NO.	REV.
4320HP06	A

FIGURE 5-1. Model 320HP (Front and Side Views) Replacement Component Locator



## SECTION 6.0 RETURN OF MATERIALS

**6.1 GENERAL.** To expedite the repair and return of instruments, proper communication between the customer and the factory is important. A return material authorization number is required. Call (949) 757-8500. The "Return of Materials Request" form is provided for you to copy and use in case the situation arises. The accuracy and completeness of this form will affect the processing time of your materials.

**6.2 WARRANTY REPAIR.** The following is the procedure for returning products still under warranty.

1. Contact the factory for authorization.
2. Complete a copy of the "Return of Materials Request" form as completely and accurately as possible.
3. To verify warranty, supply the factory sales order number or the original purchase order number. In the case of individual parts or sub-assemblies, the serial number on the mother unit must be supplied.
4. Carefully package the materials and enclose your "Letter of Transmittal" and the completed copy of the "Return of Materials Request" form. If possible, pack the materials in the same manner as it was received.

### IMPORTANT

Please see second section of "Return of Materials Request Form". Compliance to the OSHA requirements is mandatory for the safety of all personnel. MSDS forms and a certification that the instruments have been disinfected or detoxified are required.

5. Send the package prepaid to:

Emerson Process Management - Liquid Division  
2400 Barranca Parkway  
Irvine, CA 92606

Attn: Factory Repair

Mark the package:

Returned for Repair RMA No. \_\_\_\_\_

Model No. \_\_\_\_\_

### 6.3 NON WARRANTY REPAIR.

1. Contact the factory for authorization.
2. Fill out a copy of the "Return of Materials Request" form as completely and accurately as possible.
3. Include a purchase order number and make sure to include the name and telephone number of the right individual to be contacted should additional information be needed.
4. Do Steps 4 and 5 of Section 6.2.

### NOTE

Consult the factory for additional information regarding service or repair.

# RETURN OF MATERIALS REQUEST

**•IMPORTANT!**  
This form must be completed to ensure expedient factory service.

<b>C U S T O M E R</b>	<b>FROM:</b> _____ _____	<b>RETURN</b> _____ _____	<b>BILL TO:</b> _____ _____												
<b>N O T I C E T O S E N D E R</b>	<p><b>CUSTOMER/USER MUST SUBMIT MATERIAL SAFETY SHEET (MSDS) OR COMPLETE STREAM COMPOSITION, AND/OR LETTER CERTIFYING THE MATERIALS HAVE BEEN DISINFECTED AND/OR DETOXIFIED WHEN RETURNING ANY PRODUCT, SAMPLE OR MATERIAL THAT HAVE BEEN EXPOSED TO OR USED IN AN ENVIRONMENT OR PROCESS THAT CONTAINS A HAZARDOUS MATERIAL ANY OF THE ABOVE THAT IS SUBMITTED TO ROSEMOUNT ANALYTICAL WITHOUT THE MSDS WILL BE RETURNED TO SENDER C.O.D. FOR THE SAFETY AND HEALTH OF OUR EMPLOYEES. WE THANK YOU IN ADVANCE FOR COMPLIANCE TO THIS SUBJECT.</b></p>														
<p><b>SENSOR OR CIRCUIT BOARD ONLY:</b> (Please reference where from in MODEL / SER. NO. Column)</p> <table style="width:100%; border:none;"> <tr> <td style="width:33%;">1. PART NO. _____</td> <td style="width:33%;">1. MODEL _____</td> <td style="width:33%;">1. SER. NO. _____</td> </tr> <tr> <td>2. PART NO. _____</td> <td>2. MODEL _____</td> <td>2. SER. NO. _____</td> </tr> <tr> <td>3. PART NO. _____</td> <td>3. MODEL _____</td> <td>3. SER. NO. _____</td> </tr> <tr> <td>4. PART NO. _____</td> <td>4. MODEL _____</td> <td>4. SER. NO. _____</td> </tr> </table>				1. PART NO. _____	1. MODEL _____	1. SER. NO. _____	2. PART NO. _____	2. MODEL _____	2. SER. NO. _____	3. PART NO. _____	3. MODEL _____	3. SER. NO. _____	4. PART NO. _____	4. MODEL _____	4. SER. NO. _____
1. PART NO. _____	1. MODEL _____	1. SER. NO. _____													
2. PART NO. _____	2. MODEL _____	2. SER. NO. _____													
3. PART NO. _____	3. MODEL _____	3. SER. NO. _____													
4. PART NO. _____	4. MODEL _____	4. SER. NO. _____													
<b>R E A S O N F O R R E T U R N</b>	<p><b>PLEASE CHECK ONE:</b></p> <table style="width:100%; border:none;"> <tr> <td><input type="checkbox"/> REPAIR AND CALIBRATE</td> <td><input type="checkbox"/> DEMO EQUIPMENT NO. _____</td> </tr> <tr> <td><input type="checkbox"/> EVALUATION</td> <td><input type="checkbox"/> OTHER (EXPLAIN) _____</td> </tr> <tr> <td colspan="2"><input type="checkbox"/> REPLACEMENT REQUIRED? <input type="checkbox"/> YES <input type="checkbox"/> NO</td> </tr> </table> <p>DESCRIPTION OF MALFUNCTION: _____ _____</p>			<input type="checkbox"/> REPAIR AND CALIBRATE	<input type="checkbox"/> DEMO EQUIPMENT NO. _____	<input type="checkbox"/> EVALUATION	<input type="checkbox"/> OTHER (EXPLAIN) _____	<input type="checkbox"/> REPLACEMENT REQUIRED? <input type="checkbox"/> YES <input type="checkbox"/> NO							
<input type="checkbox"/> REPAIR AND CALIBRATE	<input type="checkbox"/> DEMO EQUIPMENT NO. _____														
<input type="checkbox"/> EVALUATION	<input type="checkbox"/> OTHER (EXPLAIN) _____														
<input type="checkbox"/> REPLACEMENT REQUIRED? <input type="checkbox"/> YES <input type="checkbox"/> NO															
<b>R E P A I R S T A T U S</b>	<p><b>WARRANTY REPAIR REQUESTED:</b></p> <p><input type="checkbox"/> YES-REFERENCE ORIGINAL ROSEMOUNT ANALYTICAL ORDER NO. _____ CUSTOMER PURCHASE ORDER NO. _____</p> <p><input type="checkbox"/> NO-PROCEED WITH REPAIRS-INVOICE AGAINST P.O. NO. _____</p> <p><input type="checkbox"/> NO-CONTACT WITH ESTIMATE OF REPAIR CHARGES: LETTER <input type="checkbox"/> _____ PHONE <input type="checkbox"/> _____</p>														
<p>NAME _____ PHONE _____</p> <p>ADDRESS _____</p> <p>_____ ZIP _____</p>															
<p><b>RETURN AUTHORITY FOR CREDIT ADJUSTMENT [Please check appropriate box(s)]</b></p> <table style="width:100%; border:none;"> <tr> <td><input type="checkbox"/> WRONG PART RECEIVED</td> <td><input type="checkbox"/> REPLACEMENT RECEIVED</td> </tr> <tr> <td><input type="checkbox"/> DUPLICATE SHIPMENT</td> <td>REFERENCE ROSEMOUNT ANALYTICAL SALES ORDER NO. _____</td> </tr> <tr> <td><input type="checkbox"/> RETURN FOR CREDIT</td> <td><b>RETURN AUTHORIZED BY:</b> _____</td> </tr> <tr> <td colspan="2">WARRANTY DEFECT _____</td> </tr> </table>				<input type="checkbox"/> WRONG PART RECEIVED	<input type="checkbox"/> REPLACEMENT RECEIVED	<input type="checkbox"/> DUPLICATE SHIPMENT	REFERENCE ROSEMOUNT ANALYTICAL SALES ORDER NO. _____	<input type="checkbox"/> RETURN FOR CREDIT	<b>RETURN AUTHORIZED BY:</b> _____	WARRANTY DEFECT _____					
<input type="checkbox"/> WRONG PART RECEIVED	<input type="checkbox"/> REPLACEMENT RECEIVED														
<input type="checkbox"/> DUPLICATE SHIPMENT	REFERENCE ROSEMOUNT ANALYTICAL SALES ORDER NO. _____														
<input type="checkbox"/> RETURN FOR CREDIT	<b>RETURN AUTHORIZED BY:</b> _____														
WARRANTY DEFECT _____															

24-6047

**Emerson Process Management**

**Rosemount Analytical Inc.**

2400 Barranca Parkway  
Irvine, CA 92606 USA  
Tel: (949) 757-8500  
Fax: (949) 474-7250

<http://www.raihome.com>

© Rosemount Analytical Inc. 2005



## WARRANTY

Seller warrants that the firmware will execute the programming instructions provided by Seller, and that the Goods manufactured or Services provided by Seller will be free from defects in materials or workmanship under normal use and care until the expiration of the applicable warranty period. Goods are warranted for twelve (12) months from the date of initial installation or eighteen (18) months from the date of shipment by Seller, whichever period expires first. **Consumables, such as glass electrodes, membranes, liquid junctions, electrolyte, o-rings, catalytic beads, etc., and Services are warranted for a period of 90 days from the date of shipment or provision.**

Products purchased by Seller from a third party for resale to Buyer ("Resale Products") shall carry only the warranty extended by the original manufacturer. Buyer agrees that Seller has no liability for Resale Products beyond making a reasonable commercial effort to arrange for procurement and shipping of the Resale Products.

If Buyer discovers any warranty defects and notifies Seller thereof in writing during the applicable warranty period, Seller shall, at its option, promptly correct any errors that are found by Seller in the firmware or Services, or repair or replace F.O.B. point of manufacture that portion of the Goods or firmware found by Seller to be defective, or refund the purchase price of the defective portion of the Goods/Services.

All replacements or repairs necessitated by inadequate maintenance, normal wear and usage, unsuitable power sources, unsuitable environmental conditions, accident, misuse, improper installation, modification, repair, storage or handling, or any other cause not the fault of Seller are not covered by this limited warranty, and shall be at Buyer's expense. Seller shall not be obligated to pay any costs or charges incurred by Buyer or any other party except as may be agreed upon in writing in advance by an authorized Seller representative. All costs of dismantling, reinstallation and freight and the time and expenses of Seller's personnel for site travel and diagnosis under this warranty clause shall be borne by Buyer unless accepted in writing by Seller.

Goods repaired and parts replaced during the warranty period shall be in warranty for the remainder of the original warranty period or ninety (90) days, whichever is longer. This limited warranty is the only warranty made by Seller and can be amended only in a writing signed by an authorized representative of Seller. Except as otherwise expressly provided in the Agreement, THERE ARE NO REPRESENTATIONS OR WARRANTIES OF ANY KIND, EXPRESS OR IMPLIED, AS TO MERCHANTABILITY, FITNESS FOR PARTICULAR PURPOSE, OR ANY OTHER MATTER WITH RESPECT TO ANY OF THE GOODS OR SERVICES.

## RETURN OF MATERIAL

Material returned for repair, whether in or out of warranty, should be shipped prepaid to:

**Emerson Process Management  
Liquid Division  
2400 Barranca Parkway  
Irvine, CA 92606**

The shipping container should be marked:

Return for Repair

Model \_\_\_\_\_

The returned material should be accompanied by a letter of transmittal which should include the following information (make a copy of the "Return of Materials Request" found on the last page of the Manual and provide the following thereon):

1. Location type of service, and length of time of service of the device.
2. Description of the faulty operation of the device and the circumstances of the failure.
3. Name and telephone number of the person to contact if there are questions about the returned material.
4. Statement as to whether warranty or non-warranty service is requested.
5. Complete shipping instructions for return of the material.

Adherence to these procedures will expedite handling of the returned material and will prevent unnecessary additional charges for inspection and testing to determine the problem with the device.

If the material is returned for out-of-warranty repairs, a purchase order for repairs should be enclosed.



*The right people,  
the right answers,  
right now.*

ROSEMOUNT ANALYTICAL  
CUSTOMER SUPPORT CENTER  
1-800-854-8257



**Emerson Process Management**

**Liquid Division**

2400 Barranca Parkway  
Irvine, CA 92606 USA  
Tel: (949) 757-8500  
Fax: (949) 474-7250

<http://www.raihome.com>

ON-LINE ORDERING NOW AVAILABLE ON OUR WEB SITE  
<http://www.raihome.com>

*Specifications subject to change without notice.*



Credit Cards for U.S. Purchases Only.

