



Steam and Water Analysis System

Keeping
Your Plant Online
and Powerful

ROSEMOUNT[®]
Analytical

EMERSON[™]
Process Management

Corrosion is the enemy. Emerson is your best defense

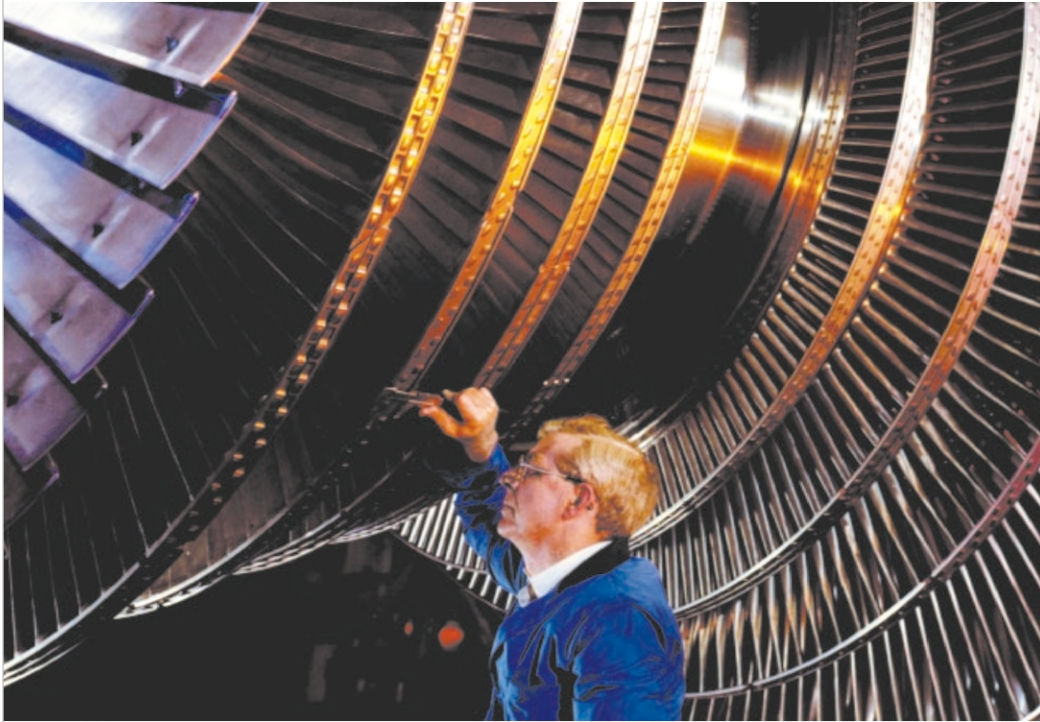

With water ever-present, corrosion is the enemy that threatens every metal surface in a power plant. Keeping water chemistry in balance is the only way to keep corrosion in check, thus ensuring the integrity of the process throughout the plant.

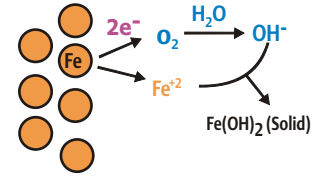

Base Metal
Simple Corrosion Reaction

In a typical power plant, water and steam are in constant contact with metal surfaces, and corrosion is ever-present.

The working fluid - water - threatens the integrity of the plant equipment: condensers, heaters, pumps, piping, boilers and turbines.

A major goal of plant chemical control is preventing solids buildup and corrosion in the plant.

Your best defense is a good offense and smart instruments and sensors from Emerson Process Management allow you to take the offense in preventative and predictive maintenance, thus minimizing expensive down time.

Fortunately, sound water treatment and chemical control along with good operating practices can do much to reduce the effects of corrosion on plant reliability.

Worldwide strength

Emerson Process Management is part of Emerson, a global company that brings together technology and engineering to provide innovative solutions for our customers in a wide range of industrial, commercial, and consumer markets. Our priority is to design, produce and deliver products, systems and solutions that make people's lives better.

Power Plant Steam Cycle Overview

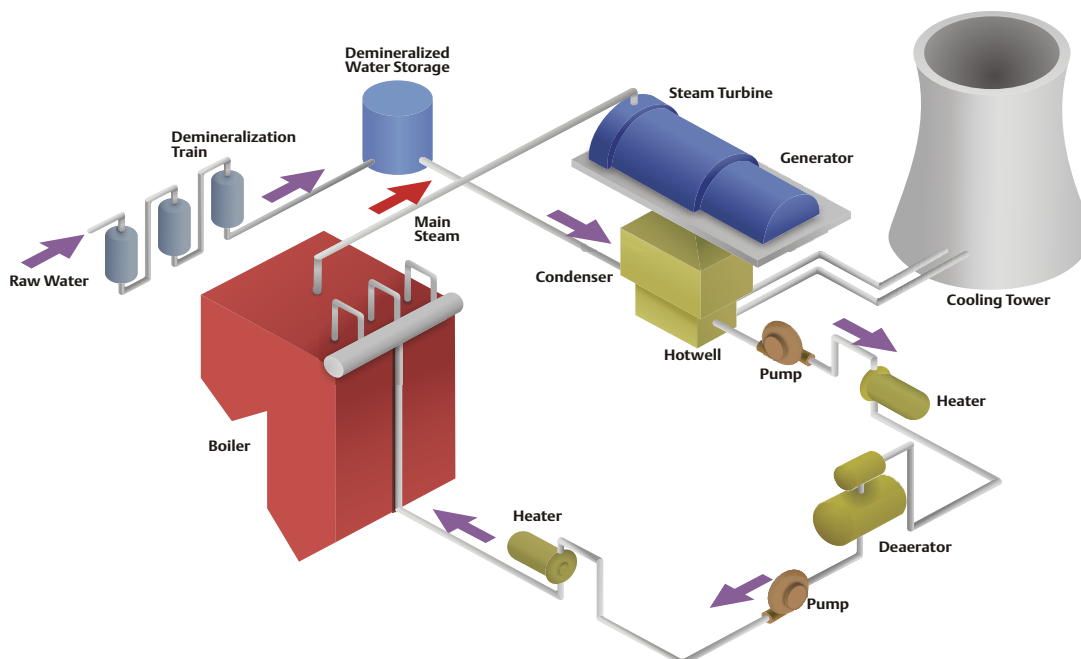

A complete solution from the System Experts



You need a partner that can deliver the best in knowledge and systems, and do it quickly, thoroughly and cost effectively. The liquid analysis professionals at Emerson Process Management along with expertise of the SENTRY, the first name in sampling system / components, are ready to put their experience to work for you. We'll evaluate your applications and provide customized solutions.

EMERSON OFFERS CUSTOMIZED STEAM & WATER ANALYSIS SYSTEM (SWAS) to ensure your plant enemies (corrosion & scaling) stay away.

- Liquid Analysis - Emerson is the world's premier provider of liquid analysers featuring products with unmatched accuracy, superior performance and worry free dependability.

- Sampling System - Designed with critical components from SENTRY such as sample coolers, Pressure Reducing Element (VREL), Back Pressure Regulator / Relief Valve (BPR / RV) and Thermal Shut off Valve (TSV)

- The Analyser Panel / Rack - We design SWAS Panel / Racks as per the plant requirement. All possible combinations e.g. Combined wet and dry section, free standing (open type rack) or walkway type (enclosed section) wet section, enclosed Dry Panel can be provided.

- Complete solution ready to install at site : Complete SWAS system duly tubed & wired, in ready to install custom build container / shell. Just connect sample and utilities to start monitoring.



Correct Sampling - Rely on Emerson & Sentry expertise



Accurate analysis of "bad" sample is of no value.

All SWAS systems are designed with critical components from SENTRY USA in line with latest ASTM guidelines (ASTM D 3370)



SAMPLE COOLERS

Compact high efficiency heat exchangers for cooling high temperature, high pressure liquid or gas samples.

- ◆ True counter flow design with baffles for close approach temperature
- ◆ Construction in accordance with ASME code section VIII



VREL® PRESSURE REDUCERS (VREL)

The VREL® is an adjustable sample pressure reducer for sample pressures above 500 psig (35 barg). A precisely machined tapered rod assembly moves inside precision holes within the barrel of the VREL. Pressure drop is a function of the length of the Rod inserted into the barrel.

- ◆ No valve erosion or fluid dissociation
- ◆ All wetted parts are fabricated from 316 SS
- ◆ The VREL® is cleanable in place

The Back Pressure Regulator (BPR) maintains constant pressure and flow through the analysers and at the same time also acts as fail safe relief valve.

Standard pressure setting - 20 psig (1.4 barg), other pressure settings available on request.

- ◆ Non-plugging design
- ◆ Will not wire draw or erode in normal service
- ◆ Fail safe relief valve

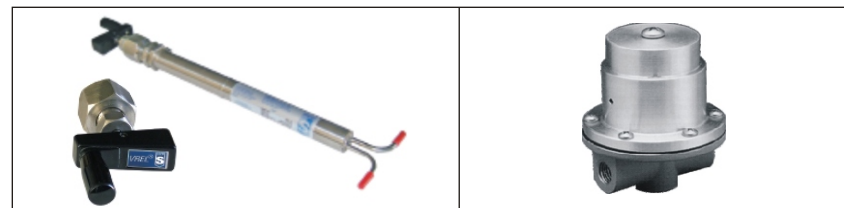
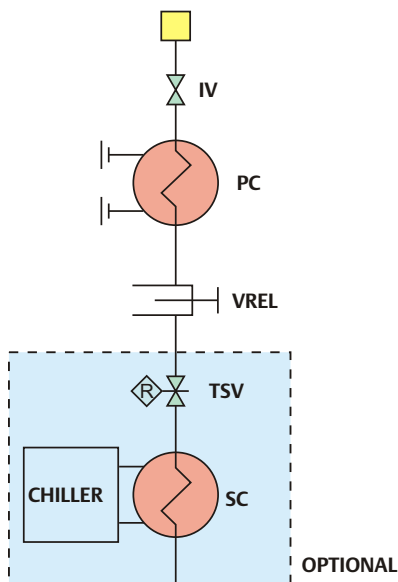

- ◆ Precise pressure reduction and control when used in conjunction with a VREL® or needle valve. Most effective way to assure a constant flow rate through on-line analysers

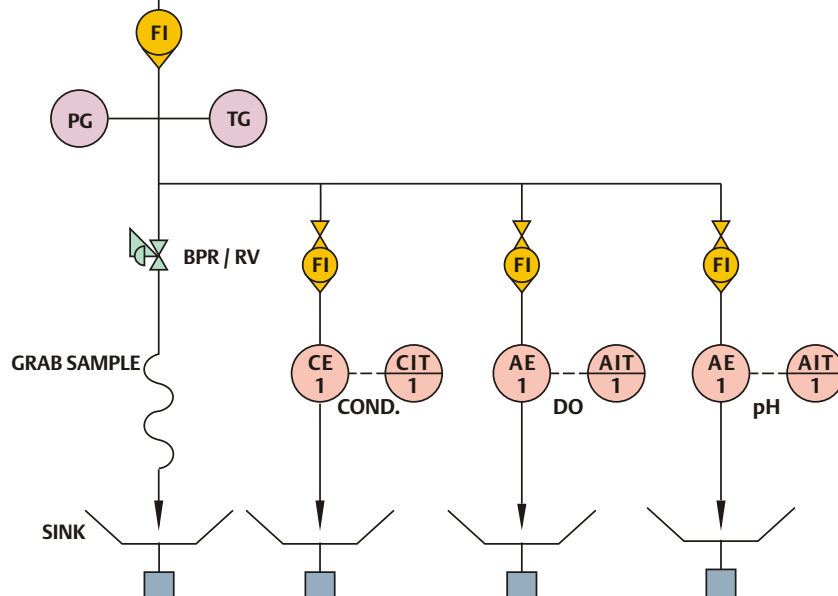

THERMAL SHUTOFF VALVE (TSV)

Protect personnel, analysers and sampling components from high temperature gases or liquids with a Sentry Thermal Shutoff Valve. The sensor/actuator is directly exposed to the sample providing near instantaneous reaction to an upset.

- ◆ Suitable for system pressures up to 4400 psi barg)
- ◆ Totally mechanical design requires no electricity air, or hydraulics
- ◆ 316 SS construction

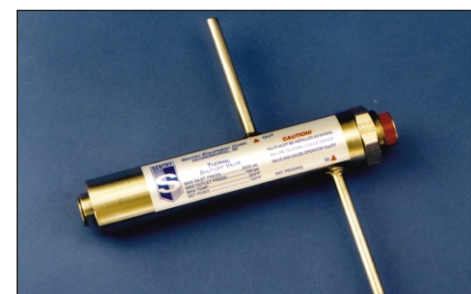

“SWAS View” - Intelligence to Predict & Prevent:

Realtime information from steam and water parameters of power plant steam cycle helps you detect process and equipment problems before they occur/or can cause damage.

By implementing a “SWAS View” you can expect to : Maximize plant availability and minimize corrosion and scaling.

“SWAS View” -

- ◆ Monitors health of your plant assets.
- ◆ Real time trend for all parameters.
- ◆ Provides window into your process.
- ◆ Bar graph display of parameters.
- ◆ Also offers an option of online monitoring, diagnostics and notification of potential problems using SMART analysers.
- ◆ Lets you detect and avoid the cause of equipment problems and failures.

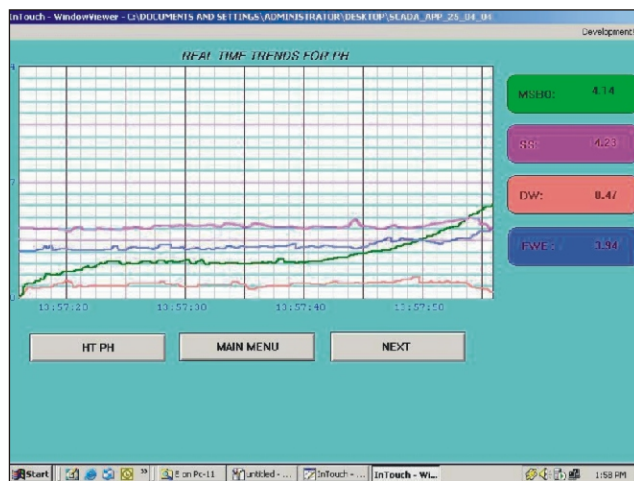

Emerson Customized Single Sample Line (CSSL) for worry free dependability

Corrosion and deposition not only result in reduced efficiency, they are also the major reasons for equipment failure. Emerson Customized Single Sample Line (CSSL) offers the flexibility to start / expand the measurement monitoring points as per the urgency and budget availability.

Emerson Customized Single Sample Line (CSSL) comes duly tubed & wired for conditioning steam & water in the plant. They can be located at the remote location near the take of front or can be grouped at common location for small number of samples.

All you need is cooling water to start monitoring!

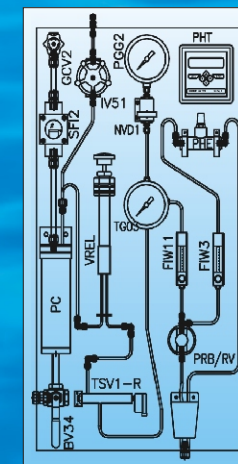

- ➔ Pre-Engineered duly tubed and wired reduces installation time and cost.
- ➔ Customized to meet the process conditions.
- ➔ Option to add Analyser /or another analysis.
- ➔ Option of free standing or wall mount.
- ➔ Scalable Design - additional CSSL can be added as and when needed.

Emerson Process Management : The Proven Source

Emerson Process Management is the proven supplier of Rosemount Analytical on-line electrochemical sensors and instrumentation with over 60 years experience in waste treatment and process control in the power industry.

In recognition of our dedication to customer service, product excellence , and quality we have received the # 1 Readers Choice Award from Control Magazine for the 13th consecutive year.

Protecting valuable assets and preventing costly unplanned outages is every power plant operator’s goal.

Waterside and steamside corrosion



poses a constant threat to efficient and reliable plant operation.

One of the most important elements in minimizing corrosion is a sound chemical control program.

Good plant chemistry requires maintaining the highest possible condensate and steam purity, carefully monitoring and controlling chemical treatment levels, and using good quality

demineralized water to replace cycle losses.

Accurate, on-line process measurement such as conductivity, cation conductivity, pH, oxygen, silica, sodium, phosphate and hydrazine play a critical role in achieving this goal as well as meeting regulatory compliance.

Count on Emerson for the systems and solutions you need in an ever changing, dynamic world.

See us on the web at www.raihome.com.

The days of grab sample analysis are over. The key to plant safety in today's environment is on-line analysis of steam and water at different points in the power plant steam cycle.

pH
Analysis of pH helps detect changes that impact the effectiveness of closing and potential corrosion of the boiler tubes.

Conductivity
Provides an indication of total dissolved solids and susceptibility to scaling.

Dissolved oxygen
Monitoring of dissolved oxygen level helps to keep the corrosion in check as, dissolved oxygen analysis help to monitor the efficiency of the deaerator.

Silica
Silica volatilizes in steam and it is carried into the turbine. Although the silica deposits are not corrosive, but they severely reduce the efficiency.

Hydrazine
It works as an oxygen scavenger, destroying traces of dissolved oxygen. Hydrazine is also passivating agent and produces a protective oxide coating on metal tube wall.



Rosemount Analytical - The only choice for continuous Measurement.

Rosemount Analytical offers the widest range pH/ORP, conductivity, TDS, percent concentration ratio, dissolved oxygen, total & free chlorine, dissolved ozone, turbidity sensors and transmitters. Instruments are simple to select depending on the power, control and communication requirement in addition to other desired features such as HART®, FOUNDATION fieldbus®, Preventive diagnostics and more.



Model 1055 SoluComp II Series (4 wire)

- ◆ Choice of single or dual measurement
- ◆ Dual measurement analysers offer a wide choice of measurement combination.
- ◆ Dual measurement reduces the cost per loop & panel space without loss of functionality.
- ◆ Ability to commission measurement in the field for added flexibility.

Analytical Sensors

Emerson's Rosemount Analytical offers the largest selection of liquid Analytical Sensors in the world to match the performance of its Advanced Analysers.

Trace Dissolved Oxygen Model 499

- ◆ Rapid Response Time
- ◆ High Sensor Accuracy (1ppb)
- ◆ Lack of flow sensitivity

Model 399 & 399 VP

- ◆ Annular ceramic junction
- ◆ Special low resistance glass electrode
- ◆ Double junction reference cell

ENDURANCE Conductivity Sensors

- ◆ Titanium electrodes for maximum stability and ruggedness without sacrificing accuracy
- ◆ Pre determined cell constant eliminates need for calibration

SMART Analysers Solucomp Model Xmt

- ◆ 2 wire transmitter with choice of HART® or FOUNDATION fieldbus®
- ◆ Option of Intrinsic Safety
- ◆ For more information refer to PDS-71-Xmt



Model 5081

- ◆ 2 wire transmitter with choice of HART® or FOUNDATION fieldbus®
- ◆ Explosion proof design.
- ◆ Intrinsic Safety Option.
- ◆ For more information refer to PDS 71-5081



Model 54c HART Analyser

- ◆ 4 wire Analyser with option of HART digital communicator
- ◆ Option of PID and TPC control.
- ◆ For more information refer to PDS-71-54e.

Silica Analyser

- ◆ One button operation
- ◆ Routine maintenance of five minutes every three months
- ◆ Self diagnostics - monitors critical functions & alerts user



Also from Emerson - Complete Solutions for the Power Industry

Rosemount Analytical has earned its leadership role by continually manufacturing products & designing solutions that set new standards in reliability and innovation. Rosemount Analytical can provide single point solutions for all your analytical needs.

COMBUSTION ANALYSIS

Emerson invented the first zirconium oxide oxygen analyser and remains the industry leader in combustion flue gas analysis. Emerson makes combustion analysers that will give your operators the confidence to run your combustion process at the most efficient fuel / air ratio.



Emission Analysis

We offer straight extractive Continuous Emission Monitoring System (CEMS) using X-stream or NGA Series of Analysers.

Rosemount Analytical CEMS goes beyond environment monitoring, enabling plant operators to optimize the process and increase uptime thereby increasing profits.



CO Analysis

Straight extractive technique for measuring CO for complete combustion.

Also available is Insitu CO Analyser model CCO 5500



CCO 5500

OCX 8800

The most dependable Oxygen / combustible transmitter in the market with world renowned zirconium oxide sensor for oxygen measurement & new patented combustible sensor.



OCX 8800A

Oxymitter 4000 SMART Insitu

Zirconium oxide based oxygen transmitter with advance sensor diagnostics; calibration recommended feature.



OXYMITTER 4000

OPM 3000 opacity /Dust density

monitor with double pass transmissometer for high performance & minimum maintenance.



OPM 3000

Our Esteemed Clients

- National Thermal Power Corporation
- Bharat Heavy Electricals Ltd.
- Torrent Power
- Siemens Ltd.
- Reliance Energy Ltd.
- Reliance Industries
- Rajasthan Vidyut Utpadan Nigam Ltd.
- Maharashtra State Electricity Board
- Thermax
- ISGEC John Thompson
- Larson & Toubro
- Toyo Engineering
- Cethar Vessel
- Thermal Systems
- RAS Gas, Qatar

Service and Support

Rosemount Analytical maintains a worldwide customer service presence. A network of highly qualified people are dedicated to meet and support your maintenance and repair needs.

APPLICATION DEVELOPMENT

Rosemount Analytical provides expert consultation to help you successfully apply our solutions to your particular application. We will take you through installation, startup, testing and documentation to help you solve your analysis problems and keep your process in compliance with applicable regulations.

MAINTENANCE PROGRAMS

Rosemount Analytical's maintenance programs provide both preventive and corrective

measures to assure continued performance / operation of your equipment. Certified Emerson Process Management field technicians can conduct these measures exclusively or in conjunction with your on - site personnel.

TRAINING

Training your in-house personnel is an integral part of our service. We offer a variety of high-quality technical training programs designed to meet your specific needs.

FIELD ASSISTANCE

Rosemount Analytical maintains a global customer service presence to provide operational assistance as needed. Our highly qualified field personnel are certified in accordance with applicable industry standards.



Regd. Office & HO :
Emerson Process Management (India) Pvt. Ltd.
D' wing, 2nd Floor, Modern Mills Compound,
Mahalaxmi, Mumbai - 400 011.
Tel: 022-66620566. Fax : 022 - 66620500
E-mail : Marcom@EmersonProcess.co.in
Corporate Website : www.EmersonProcess.com

www.raihome.com

Works :
Emerson Process Management (India) Pvt. Ltd.
82, Panchal Udyog Nagar, Bhimpore
Nani Daman, Daman - 396210
Tel.: (0260) 2220561/ 1562
Fax : (0260) 2220910, 2220713

ROSEMOUNT[®]
Analytical

EMERSON[™]
Process Management