Rosemount Analytical

**MODEL 755A
OXYGEN ANALYZER**

INSTRUCTION MANUAL

245364-U

NOTICE

The information contained in this document is subject to change without notice.

Teflon® is a registered trademark of E.I. duPont de Nemours and Co., Inc.
SNOOP® is a registered trademark of NUPRO Co.

Manual Part Number 245364-U
April 2000
Printed in U.S.A.

Rosemount Analytical Inc.
4125 East La Palma Avenue
Anaheim, California 92807-1802

CONTENTS

PREFACE

INTENDED USE STATEMENT	P-1
SAFETY SUMMARY	P-1
SPECIFICATIONS - GENERAL	P-3
SPECIFICATIONS - SAMPLE	P-3
SPECIFICATIONS - ELECTRICAL.....	P-4
SPECIFICATIONS - PHYSICAL.....	P-5
CUSTOMER SERVICE, TECHNICAL ASSISTANCE AND FIELD SERVICE	P-6
RETURNING PARTS TO THE FACTORY	P-6
TRAINING	P-6
DOCUMENTATION.....	P-6
COMPLIANCES	P-7

SECTION 1. INTRODUCTION

1.1 OVERVIEW	1-1
1.2 OXYGEN RANGE ON FRONT PANEL DIGITAL DISPLAY	1-2
1.3 OXYGEN RANGES FOR RECORDER READOUT.....	1-2
1.4 RECORDER VOLTAGE AND CURRENT OUTPUTS	1-3
1.5 AUTOMATIC PRESSURE COMPENSATION.....	1-3
1.6 ALARM (OPTION)	1-3
1.7 CASE MOUNTING OPTIONS	1-3
1.8 ELECTRICAL POWER OPTIONS.....	1-3

SECTION 2. UNPACKING AND INSTALLATION

2.1 UNPACKING	2-1
2.2 LOCATION	2-1

SECTION 2. (CONTINUED)

2.2.1	Location and Mounting	2-1
2.3	VOLTAGE REQUIREMENTS	2-1
2.4	ELECTRICAL CONNECTIONS.....	2-2
2.4.1	Line Power Connections.....	2-2
2.4.2	Recorder Connections.....	2-2
2.4.3	Output Connections for Dual Alarm Option	2-5
2.5	CALIBRATION	2-8
2.5.1	Zero Calibration Gas	2-8
2.5.2	Downscale Standard Gas.....	2-8
2.5.3	Upscale Standard Gas	2-8
2.6	SAMPLE HANDLING	2-8
2.6.1	Sample Temperature Requirements.....	2-8
2.6.2	Sample Pressure Requirements: General.....	2-9
2.6.3	Normal Operation at Positive Gauge Pressures.....	2-10
2.6.4	Operation at Negative Gauge Pressures.....	2-10
2.6.5	Sample Flow Rate	2-10
2.6.6	Corrosive Gases.....	2-11
2.7	LEAK TEST.....	2-11
2.8	PURGE KIT (OPTIONAL)	2-12

SECTION 3. INITIAL STARTUP AND CALIBRATION

3.1	SELECTION OF RECORDER OXYGEN RANGE	3-1
3.1.1	Recorder Oxygen Range Selection Procedure.....	3-1
3.1.2	Readout of Applied Zero-Suppression Voltage on Digital Display.....	3-5
3.2	STARTUP PROCEDURE.....	3-6
3.3	CALIBRATION	3-7
3.3.1	Calibration Using Digital Readout for Oxygen Readout.....	3-7
3.3.2	Calibration Using Recorder for Oxygen Readout	3-7
3.3.3	Calibration with Downscale and Upscale Standard Gases.....	3-8
3.3.4	Calibration of Automatic Pressure Compensation	3-9
3.4	COMPENSATION FOR COMPOSITION OF BACKGROUND GAS	3-10
3.4.1	Oxygen Equivalent Values of Gases	3-11
3.4.2	Computing Adjusted Settings for Zero and Span Controls	3-11
3.5	DUAL ALARM OPTION	3-13
3.5.1	Initial Calibration and Selection of Setpoints for Alarms.....	3-13
3.5.2	Selection of Deadband	3-14

SECTION 4. ROUTINE OPERATION

4.1	ROUTINE OPERATION	4-1
4.2	EFFECT OF BAROMETRIC PRESSURE CHANGES ON INSTRUMENT READOUT	4-1
4.3	CALIBRATION FREQUENCY	4-1

SECTION 5. THEORY

5.1	PRINCIPLES OF OPERATION	5-1
5.2	VARIABLES INFLUENCING PARAMAGNETIC OXYGEN MEASUREMENTS	5-5
5.2.1	Pressure Effects	5-5
5.2.2	Temperature Effects	5-5
5.2.3	Interferents	5-6
5.2.4	Vibration Effects	5-6
5.3	ELECTRONIC CIRCUITRY	5-6
5.3.1	Detector/Magnet Assembly	5-7
5.3.2	Control Board and Associated Circuitry	5-7
5.3.3	Case Board	5-9
5.3.4	Isolated Current Output Board (Optional)	5-10
5.3.5	Alarm Option	5-10

SECTION 6. ELECTRONIC CIRCUIT ANALYSIS

6.1	OVERVIEW	6-1
6.2	± 15 VDC POWER SUPPLY	6-1
6.3	CASE HEATER CONTROL CIRCUIT	6-1
6.4	DETECTOR HEATER CONTROL CIRCUIT	6-6
6.5	DETECTOR LIGHT SOURCE CONTROL CIRCUIT	6-7
6.6	DETECTOR WITH FIRST STAGE AMPLIFIER AND PRESSURE COMPENSATION CIRCUITS	6-8
6.7	BUFFER AMPLIFIERS U10 AND ASSOCIATED ANTICIPATION FUNCTION	6-12
6.8	DIGITAL OUTPUT CIRCUIT	6-12
6.9	ANALOG OUTPUT CIRCUITS FOR RECORDER AND ALARMS	6-13

SECTION 7. ROUTINE SERVICE AND MAINTENANCE

7.1	INITIAL CHECKOUT WITH STANDARD GASES.....	7-1
7.2	DETECTOR COMPONENT CHECKS	7-2
7.2.1	Detector	7-2
7.2.2	Source Lamp	7-2
7.2.3	Photocell.....	7-2
7.2.4	Suspension.....	7-3
7.3	DETECTOR COMPONENT REPLACEMENT	7-3
7.3.1	Detector Replacement.....	7-3
7.3.2	Source Lamp Replacement	7-5
7.3.3	Photocell Replacement and Adjustment.....	7-7
7.4	HEATING CIRCUITS	7-8
7.4.1	Case Heater Control Circuit.....	7-8
7.4.2	Detector/Magnet Heating Circuit	7-9

SECTION 8. REPLACEMENT PARTS

8.1	CIRCUIT BOARD REPLACEMENT POLICY	8-1
8.2	SELECTED REPLACEMENT PARTS	8-1

GENERAL PRECAUTIONS FOR STORING AND HANDLING HIGH PRESSURE GAS CYLINDERS

WARRANTY

FIELD SERVICE AND REPAIR FACILITIES

FIGURES

1-1 Model 755A Oxygen Analyzer 1-1

1-2 Analyzer Components and Adjustments Locations 1-4

2-1 Electrical Connections 2-3

2-2 Control Board 2-4

2-3 Connections for Potentiometric Recorder with Non-Standard Span 2-4

2-4 Analyzer Connected to Drive Several Current-Activated Output
Devices 2-5

2-5 Typical Alarm Settings 2-7

2-6 Relay Terminal Connections for Typical Fail-Safe Application 2-7

2-7 Connection of Typical Gas Selector Panel to Analyzer 2-9

2-8 Installation of Purge Kit (Optional) 2-13

3-1 Front Panel Controls 3-2

3-2 Internal Adjustments Locations 3-5

3-3 Calibration by Pressure Decrease Setup 3-9

3-4 Schematic Circuit of Alarm Relay Assembly 3-14

5-1 Spherical Body in Non-Uniform Magnetic Field 5-2

5-2 Functional Diagram of Paramagnetic Oxygen Measurement System 5-3

5-3 Detector/Magnet Assembly 5-4

6-1 Two-Comparator OR Circuit 6-2

6-2 Ramp Generator 6-3

6-3 Case Heater Control Circuit 6-4

6-4 Case Heater Circuit 6-5

6-5 Detector Heater Control Circuit 6-7

6-6 Detector Light Source Control Circuit 6-8

6-7 Detector with First Stage Amplifier and Pressure Compensation
Circuits 6-11

6-8 Pressure Signal and Reference Voltage Circuits 6-11

6-9 Buffer, Anticipation, and Digital Output Circuit 6-12

6-10 Simplified Analog Output Circuit for Recorder (Showing Three
Ranges) 6-15

7-1 Detector/Magnet Assembly 7-4

7-2 Detector/Magnet Assembly Wiring 7-5

7-3 Detector Adjustment 7-5

7-4 Modification of 633689 Connector Board for Compatibility with
Replacement Lamp 7-7

7-5 Lamp Alignment 7-7

TABLES

3-1 Internal Adjustments 3-4

3-2 Standard Gases Recommended for Calibration of Various Oxygen
Ranges on Analog Output 3-8

3-3 Oxygen Equivalents of Common Gases 3-12

DRAWINGS (LOCATED IN REAR OF MANUAL)

617186	Schematic Diagram, Master Board Assembly (Case)
617731	Pictorial Wiring Diagram, Model 755A
620434	Schematic Diagram, 0 to 20 mA or 4 to 20 mA Current Output
632349	Installation Drawing, Model 755A
652219	Schematic Diagram, Control Board
652222	Schematic Diagram, Transducer

PREFACE

INTENDED USE STATEMENT

The Model 755A is intended for use as an industrial process measurement device only. It is not intended for use in medical, diagnostic, or life support applications, and no independent agency certifications or approvals are to be implied as covering such applications.

SAFETY SUMMARY

To avoid explosion, loss of life, personal injury and damage to this equipment and on-site property, all personnel authorized to install, operate and service the Model 755A Oxygen Analyzer should be thoroughly familiar with and strictly follow the instructions in this manual. **Save these instructions.**

DANGER is used to indicate the presence of a hazard which **will** cause **severe** personal injury, death, or substantial property damage if the warning is ignored

WARNING is used to indicate the presence of a hazard which **can** cause **severe** personal injury, death, or substantial property damage if the warning is ignored.

CAUTION is used to indicate the presence of a hazard which **will** or **can** cause **minor** personal injury or property damage if the warning is ignored.

NOTE is used to indicate installation, operation, or maintenance information which is important but not hazard-related.



WARNING: ELECTRICAL SHOCK HAZARD

Do not operate without doors and covers secure. Servicing requires access to live parts which can cause death or serious injury. Refer servicing to qualified personnel.

For safety and proper performance this instrument must be connected to a properly grounded three-wire source of power.



WARNING: POSSIBLE EXPLOSION HAZARD

This analyzer is of a type capable of analysis of sample gases which may be flammable. If used for analysis of such gases, the instrument must be either in an explosion-proof enclosure suitable for the gas, or, protected by a continuous dilution purge system in accordance with Standard ANSI/NFPA-496-1086 (Chapter 8) or IEC Publication 79-2-1983 (Section Three).

If gases are introduced into this analyzer, the sample containment system must be carefully leak-checked upon installation and before initial start-up, during routine maintenance and any time the integrity of the sample containment system is broken, to ensure the system is in leak-proof condition. Leak-check instructions are provided in Section 2.7.

Internal leakage of sample resulting from failure to observe these precautions could result in an explosion causing death, personal injury, or property damage.



CAUTION: PARTS INTEGRITY

Tampering or unauthorized substitution of components may adversely affect safety of this product. Use only factory documented components for repair.



WARNING: HIGH PRESSURE GAS CYLINDERS

This analyzer requires periodic calibration with known zero and standard gases. Refer to Sections 2.5 and 2.6. See also General Precautions for Handling and Storing High Pressure Cylinders, in the rear of this manual.

SPECIFICATIONS - GENERAL

OPERATING RANGE

0.00% to 100.0% oxygen

RECORDER RANGE

Selectable for 0% to 100% oxygen or for any desired span of 1%, 2%, 5%, 10%, 20% or 100% oxygen within the overall range.

RESPONSE TIME

(90% of fullscale) recorder output factory set for 20 seconds; adjustable from 5 to 25 seconds.

REPRODUCIBILITY (DIGITAL DISPLAY)

$\pm 0.01\%$ Oxygen ± 2 counts.

AMBIENT TEMPERATURE LIMITS

Maximum: 49°C (120°F) EXCEPT 38°C (100°F) for 99% to 100% oxygen.

Minimum: -7°C (20°F) EXCEPT 4°C (40°F) for 99% to 100% oxygen.

ZERO AND SPAN DRIFT¹

Within $\pm 1\%$ of fullscale ($\pm 2\%$ of fullscale for 99% to 100% range) per 24 hours, provided that ambient temperature does not change by more than 11.1°C (20°F).

$\pm 2.5\%$ of fullscale per 24 hours with ambient temperature change over entire range.

BAROMETRIC PRESSURE COMPENSATION

Oxygen readout automatically corrected to within $\pm 1\%$ of fullscale for barometric pressure variations within $\pm 3\%$ of target value and within $\pm 2\%$ of fullscale for barometric pressure variations within $\pm 5\%$ of target value.

The target may be set anywhere within range of -2.7 to 3.3 psig ± 3 psig (-18.6 to 22.8 kPa ± 21 kPa).

Exhaust vented to atmosphere.

SPECIFICATIONS - SAMPLE

DRYNESS

Sample dewpoint below 43°C (110°F), sample free of entrained liquids.

TEMPERATURE LIMITS

Maximum: 66°C (150°F)

Minimum: 10°C (50°F)

¹ Zero and span drift specifications based on following conditions: Operating pressure constant; ambient temperature change from initial calibration temperature, less than 11.1 Celsius degrees (20 Fahrenheit degrees); deviation from set flow held to within $\pm 10\%$ or ± 20 cc/min, whichever is smaller.

SPECIFICATIONS - SAMPLE (CONTINUED)

OPERATING PRESSURE

Maximum: 69 kPa (10 psig).
Minimum: -13.1 kPa (-1.9 psig)

FLOW RATE²

Maximum: 500 cc/min
Minimum: 50 cc/min
Recommended: 250 ±20 cc/min

MATERIALS IN CONTACT WITH SAMPLE GAS

316 stainless steel, glass, titanium, Paliney No. 7, epoxy resin, Viton-A, platinum, nickel.

SPECIFICATIONS - ELECTRICAL

SUPPLY VOLTAGE AND FREQUENCY

Standard: 115 VAC ±10 VAC, 50/60 Hz
Optional: 230 VAC ±10 VAC, 50/60 Hz

POWER CONSUMPTION

Maximum: 300 watts
Nominal: 75 watts

OUTPUT

Standard: Field selectable voltage output of 0 to 10mV, 0 to 100mV, 0 to 1V, or 0 to 5VDC
Optional: Isolated current output of 0 to 20mA or 4 to 20mA (with Current Output Board)

ALARM OPTION

High-Low Alarm
Contact Ratings:
5 amperes, 240V AC, resistive load
5 amperes, 120V AC, resistive load
5 amperes, 28V DC, resistive load

SETPOINT

Adjustable from 1% to 20% of fullscale

DEADBAND

Adjustable from 1% to 20% of fullscale (Factory set at 10% of fullscale)

² Deviation from set flow would be held to within ±10% or ±20 cc/min, whichever is smaller. If so, zero and span drift will be within specifications, provided that operating temperature remains constant.

SPECIFICATIONS - PHYSICAL

MOUNTING

Standard: Panel mount

Optional: Surface or stanchion mount accessory available

ENCLOSURE CLASSIFICATION

Meets requirements for NEMA 3R

Air Purge Option³: NFPA 496 (1989) Type Z purge

WEIGHT

Approximately 32.5 lbs (14.74 Kg)

DIMENSIONS

Height: 13.5 (343 mm)

Width: 11.5 (294 mm)

Depth: 7.12 (181 mm)

³ When installed with user supplied components, meets requirements for Class I, Division 2 locations per National Electrical Code (ANSI/NFPA 70) for analyzers sampling nonflammable gases. Analyzers sampling flammable gases must be protected by a continuous dilution purge system in accordance with Standard ANSI/NFPA 496-1986, Chapter 8. Consult factory for recommendations.

CUSTOMER SERVICE, TECHNICAL ASSISTANCE AND FIELD SERVICE

For order administration, replacement Parts, application assistance, on-site or factory repair, service or maintenance contract information, contact:

**Rosemount Analytical Inc.
Process Analytical Division
Customer Service Center
1-800-433-6076**

RETURNING PARTS TO THE FACTORY

Before returning parts, contact the Customer Service Center and request a Returned Materials Authorization (RMA) number. Please have the following information when you call: *Model Number, Serial Number, and Purchase Order Number or Sales Order Number.*

Prior authorization by the factory must be obtained before returned materials will be accepted. Unauthorized returns will be returned to the sender, freight collect.

When returning any product or component that has been exposed to a toxic, corrosive or other hazardous material or used in such a hazardous environment, the user must attach an appropriate Material Safety Data Sheet (M.S.D.S.) or a written certification that the material has been decontaminated, disinfected and/or detoxified.

Return to:

**Rosemount Analytical Inc.
4125 East La Palma Avenue
Anaheim, California 92807-1802**

TRAINING

A comprehensive Factory Training Program of operator and service classes is available. For a copy of the *Current Operator and Service Training Schedule* contact the Technical Services Department at:

**Rosemount Analytical Inc.
Phone: 1-714-986-7600
FAX: 1-714-577-8006**

DOCUMENTATION

The following Model 755A Oxygen Analyzer instruction materials are available. Contact Customer Service or the local representative to order.

245364 Instruction Manual (this document)

COMPLIANCES

The Model 755A Oxygen Analyzer (General Purpose Enclosure) has been designed to meet the applicable requirements of the U.S. Occupational Safety and Health Act (OSHA) of 1970 if installed in accordance with the requirements of the National Electrical Code (NEC) of the United States in non-hazardous areas and operated and maintained in the recommended manner.

This product may carry approvals from a certifying agency or may be in compliance with EMC Directive. If so, the product will carry approval insignia, like those shown here, on the product name rating plate.



NOTES

1 INTRODUCTION

1.1 OVERVIEW

The Model 755A Oxygen Analyzer provides digital readout of the oxygen content of a flowing gas sample. Oxygen is strongly paramagnetic; other common gases, with only a few exceptions, are weakly diamagnetic.

A front panel liquid crystal display provides direct digital readout of oxygen concentration. In addition a field-selectable voltage output is provided as standard. An isolated current output of 0 to 20 mA or 4 to 20 mA is obtainable with the optional Current Output Board. Current and voltage output may be utilized simultaneously if desired.

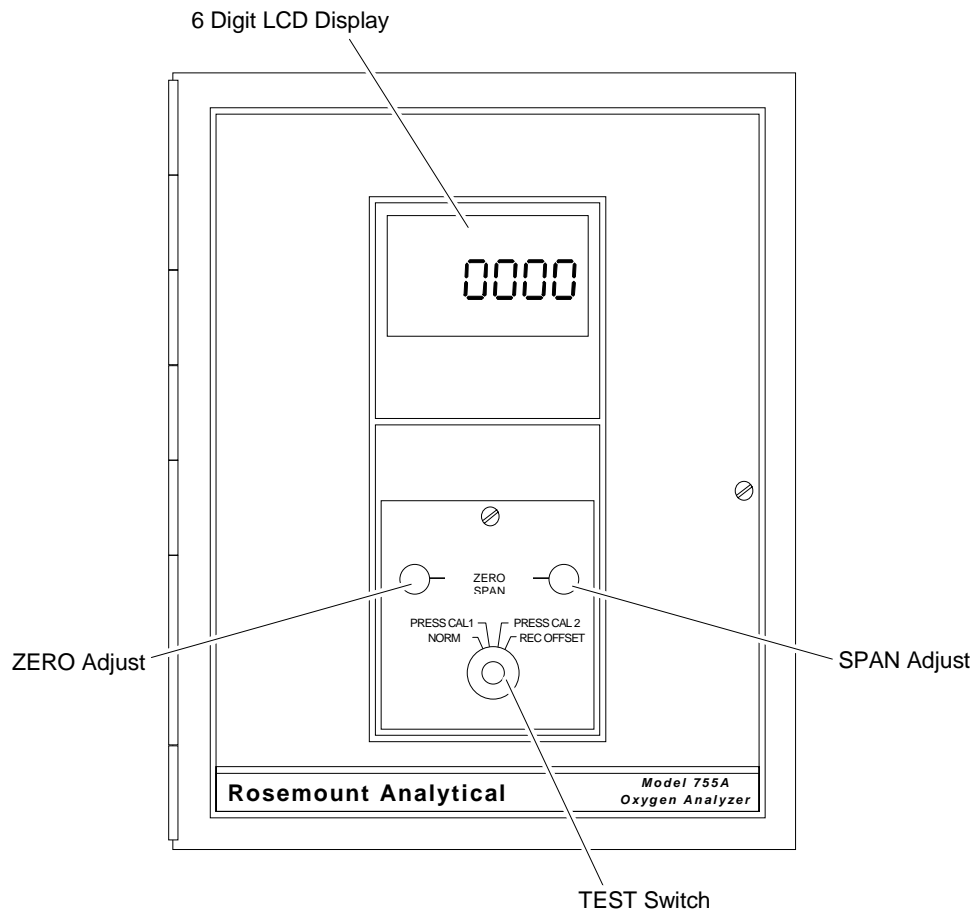

FIGURE 1-1. MODEL 755A OXYGEN ANALYZER

The basic electronic circuitry is incorporated into two master boards: The Control Board Assembly and the Case Circuit Board Assembly (see Figure 1-2). The Control Board has a receptacle which accepts optional circuit boards, thus permitting inclusion of such features as current output.

1.2 OXYGEN RANGE ON FRONT PANEL DIGITAL DISPLAY

The front panel LCD (liquid crystal display) provides direct readout of oxygen concentration from 0.00% to 100.00%.

1.3 OXYGEN RANGES FOR RECORDER READOUT

If desired, the recorder output may be set for a fullscale range of 0 to 100% oxygen. Alternatively, a desired portion of this overall range may be selected for fullscale presentation on the recorder. The selection is made by an appropriate combination of scale expansion and zero suppression.

SCALE EXPANSION

Fullscale oxygen span for the recorder is switch selectable for 1%, 2%, 5%, 10%, 20%, or 100% oxygen.

ZERO SUPPRESSION

The desired zero suppression is obtained as the sum of (a) a jumper selectable fixed value of 0%, 20%, 40%, 60% or 80% oxygen and (b) a continuously adjustable value of 0% to 25% oxygen. Thus the electronic circuitry provides the capability of setting the total zero suppression for any desired value from 0% up to a theoretical maximum of 105% oxygen.

However, the maximum usable zero suppression is 99%, which is used in establishing a range of 99% to 100%.

The effective zero suppression, in volts, may be read on the digital display by placing the front panel TEST Switch in position 4 and the Reorder Oxygen Span Selection Switch in 1 X gain position (i.e., 100% oxygen)

Example:

Desired oxygen range for recorder output: 99% to 100% oxygen.

Required span is 1% oxygen, obtained by jumper position.

Required zero suppression is 99% oxygen. Thus, fixed zero suppression of 80% oxygen is selected by jumper position, and adjustable zero suppression is set for 19% oxygen.

1.4 RECORDER VOLTAGE AND CURRENT OUTPUTS

VOLTAGE OUTPUTS (STANDARD)

Provided a standard is a jumper selectable voltage output of 0 to 10 mV, 0 to 100 mV, 0 to 1 V, or 0 to 5 V DC.

ISOLATED CURRENT OUTPUT (OPTION)

An isolated current output is obtainable with the optional Current Output Board, either included with the Model 755A or added at a later date in the field.

This option provides a current output of either 0 to 20mA or 4 to 20mA for a maximum of 850 ohms.

Refer to Section 8, Replacement Parts, for the part number of the Isolated Current Output option.

Note

Voltage and current outputs may be used simultaneously, if desired.

1.5 AUTOMATIC PRESSURE COMPENSATION

The oxygen readout is automatically corrected for pressure variations within 3% of the target value, which may be set anywhere within the range of -2.7 to 3.3 psig \pm 3 psig (-18.6 to 22.8 kPa \pm 21 kPa).

1.6 ALARM (OPTION)

The analyzer has an alarm relay assembly consisting of two single-pole, double-throw relays, one each for the ALARM 1 and ALARM 2 contacts. These relays may be used to drive external, customer-supplied alarm and/or control devices.

1.7 CASE MOUNTING OPTIONS

The analyzer is supplied, as ordered, with hardware for one of three mounting arrangements: Panel, wall, or pipe stanchion.

1.8 ELECTRICAL POWER OPTIONS

The analyzer is supplied, as ordered, for operation on either 120 VAC, 50/60 Hz, or 240 VAC, 50/60 Hz.

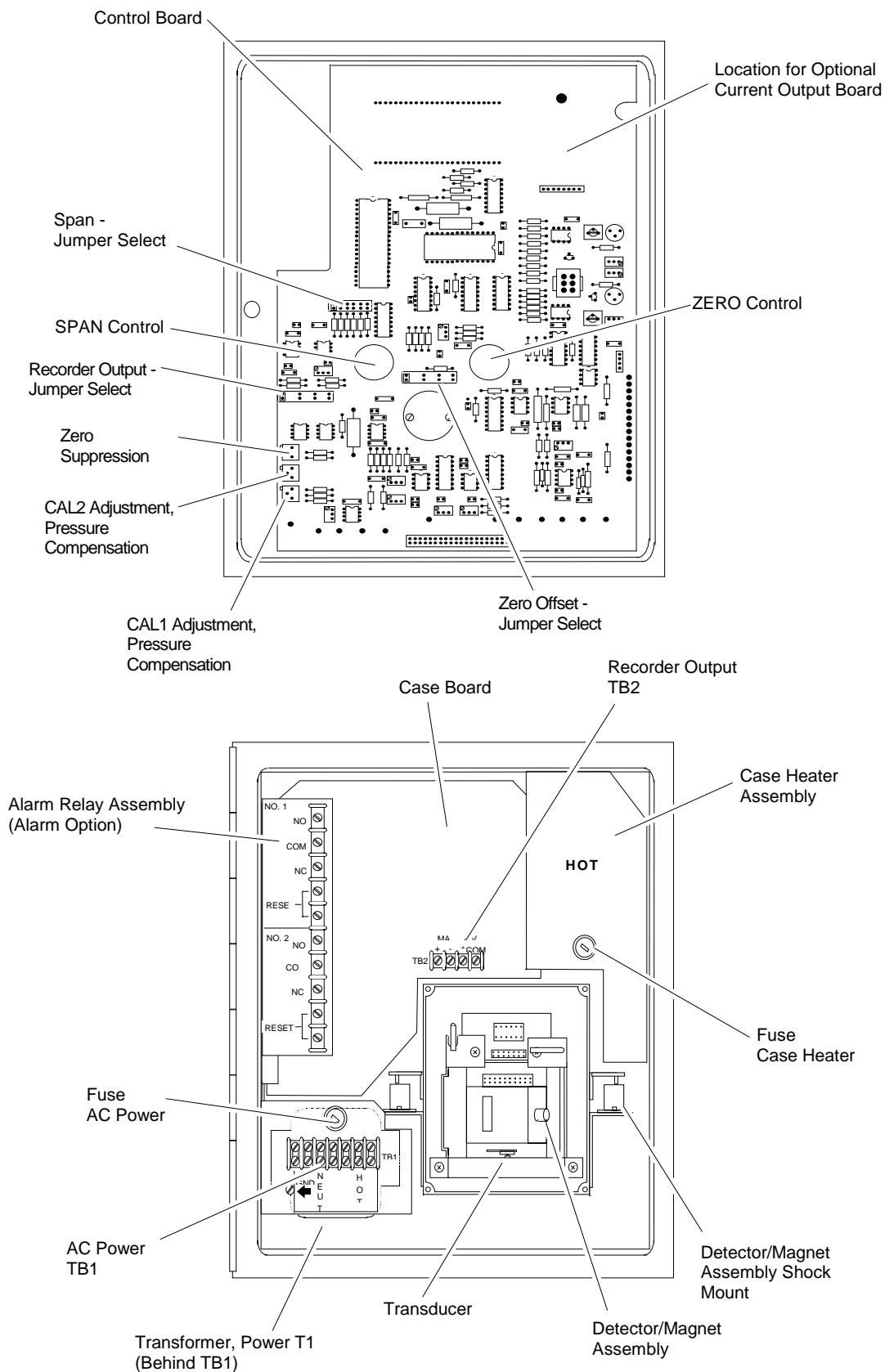

FIGURE 1-2. MODEL 755A COMPONENTS AND ADJUSTMENTS LOCATIONS

2 UNPACKING AND INSTALLATION

2.1 UNPACKING

Carefully examine the shipping carton and contents for signs of damage. Immediately notify the shipping carrier if the carton or its contents are damaged. Retain the carton and packing materials until the instrument is operational.

2.2 LOCATION

2.2.1 LOCATION AND MOUNTING

The analyzer is designed to meet NEMA 3R enclosure requirements and may be mounted outdoors. Permissible ambient temperature range is 20°F to 120°F (-7°C to 49°C).

Avoid mounting outside in direct sunlight, or inside in a closed building, where ambient temperature may exceed the allowable maximum.

Shock and mechanical motion can reduce instrument accuracy; therefore, mount the instrument in an area that is as vibration free as possible

2.3 VOLTAGE REQUIREMENTS



WARNING: ELECTRICAL SHOCK HAZARD

Do not operate without doors and covers secure. Servicing requires access to live parts which can cause death or serious injury. Refer servicing to qualified personnel.

For safety and proper performance this instrument must be connected to a properly grounded three-wire source of power.

Note

Refer to Installation Drawing 642349 at the rear of this manual for recommended cable conduit openings.



CAUTION: ENCLOSURE INTEGRITY

With reference to Installation Drawing 642349, any unused cable conduit openings must be securely sealed by permanent closures in order to provide enclosure integrity in compliance with personnel safety and environmental protection requirements. The plastic closures provided are for shipping protection only.

Note

For NEMA 3R service, all conduit must be connected through approved fittings.

This instrument was shipped from the factory configured to operate on 115 VAC or 240 VAC, 50/60 Hz electric power. Verify that the power source conforms to the requirements of the individual instrument, as noted on the name-rating plate.

2.4 ELECTRICAL CONNECTIONS

2.4.1 LINE POWER CONNECTIONS

Electrical power is supplied to the analyzer via a customer-supplied, three-conductor cable, type SJT, minimum wire size 18 AWG. Route power cable through conduit and into appropriate opening in the instrument case (see Installation Drawing 642349). Connect power leads to HOT, NEUT, AND GND terminals on TB1, see Figure 2-1. Connect analyzer to power source via an external fuse, in accordance with local codes.

Note

Do not draw power for associated equipment from the analyzer power cable.

2.4.2 RECORDER CONNECTIONS

Note

Route recorder cable through a separate conduit, not with power cable or alarm output cable.

If a recorder, controller, or other output device is used, connector it to the analyzer via a 24-22 AWG two-conductor shielded cable.

Route the cable through conduit to the analyzer and into the case through the appropriate opening shown in Installation Drawing 642349. Connect the shield only at the recorder or computer, if used.

Cable connections and output selection for potentiometric and current actuated

devices are explained in below.

POTENTIOMETRIC OUTPUT

Insert Recorder Output Selection Jumper, Figure 2-2, in position appropriate to the desired output; 10 mV, 100 mV, 1V or 5V.

On TB2, Figure 2-1, connect leads of shielded recorder cable to "MV+" AND "COM" terminals.

Connect free end of output cable to appropriate terminals of recorder or other potentiometric device.

For device with a span of 0 to 10mV, 0 to 100mV, 0 to 1V, or 0 to 5V, connect cable directly to input terminals of the device, making sure polarity is correct.

For device with intermediate span, i.e., between the specified values, connect cable to device via a suitable external voltage divider, as shown in Figure 2-3.

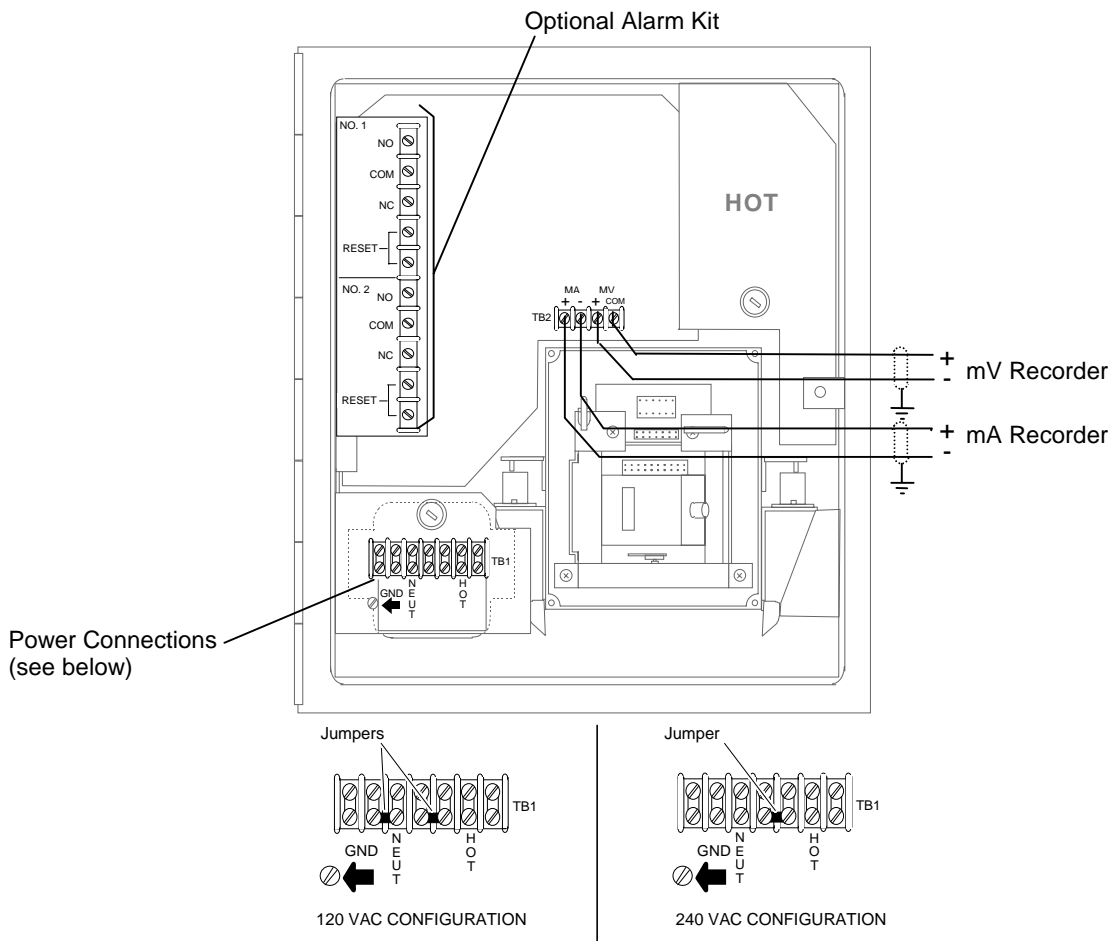

FIGURE 2-1. ELECTRICAL CONNECTIONS

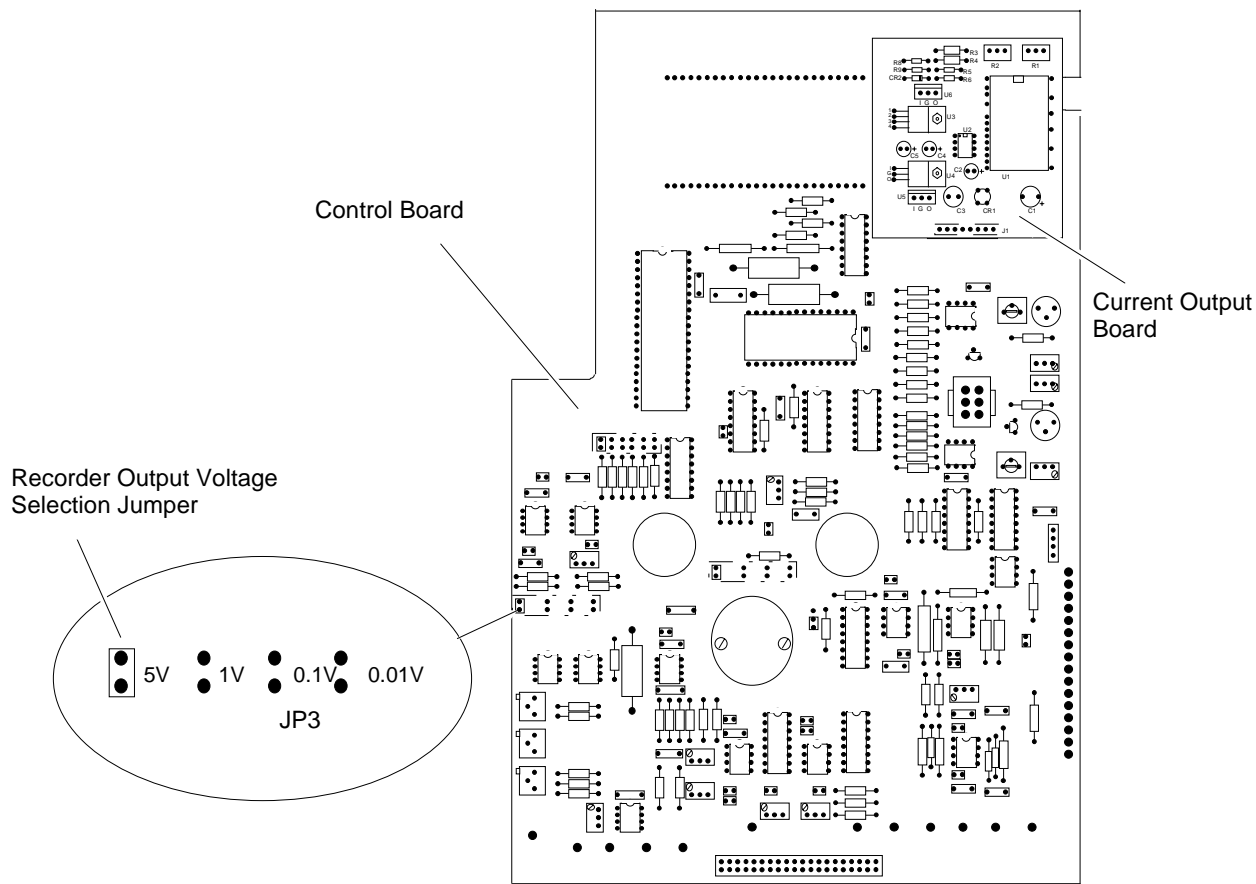
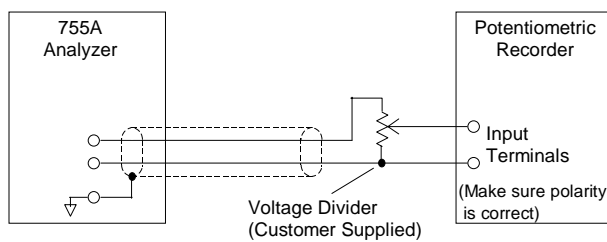

FIGURE 2-2. CONTROL BOARD



Position of Recorder Output Selector Plug	Minimum Permissible Resistance for R1 + R2
10 mV	1K Ohm
100 mV	10K Ohm
1 V	100K Ohm
5 V	2K Ohm

FIGURE 2-3. CONNECTIONS FOR POTENTIOMETRIC RECORDER WITH NON-STANDARD SPAN

ISOLATED CURRENT OUTPUT (OPTIONAL)

1. Verify that the Current Output Board appropriate to desired output is properly in place. See Figure 2-2. If originally ordered with analyzer, the board is factory installed.
2. On TB2, Figure 2-1, connect leads of shielded recorder cable to "MA+" and "-" terminals.
3. Connect free end of output cable to input terminals of recorder or other current actuated device, making sure that polarity is correct. If two or more current-actuated devices are to be used, they must be connected in series as shown in Figure 2-4.

Total resistance of all output devices and associated interconnection cable must not exceed 850 ohms.

Current and voltage outputs may be utilized simultaneously, if desired.

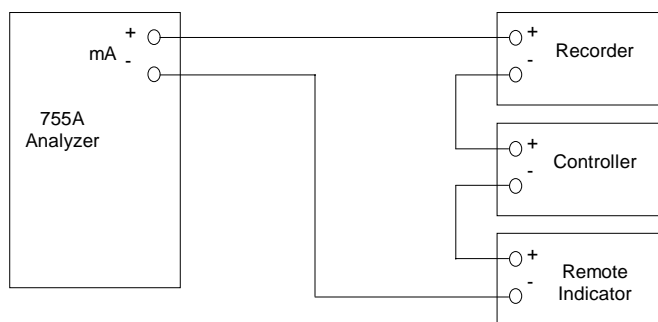

FIGURE 2-4. MODEL 755A CONNECTED TO DRIVE SEVERAL CURRENT-ACTIVATED OUTPUT DEVICES

2.4.3 OUTPUT CONNECTIONS FOR DUAL ALARM OPTION

If so ordered, the analyzer is factory-equipped with alarm output. Alternatively, the alarm feature is obtainable by subsequent installation of the 618083 Alarm Relay Kit.

ALARM OUTPUT CONNECTIONS

The alarm output provides two sets of relay contacts for actuation of alarm and/or process control functions. Leads from the (customer-supplied) external alarm system connect to terminals on the 638254 Alarm Relay Assembly (see Figure 2-1).

Note the following recommendations:

1. A line fuse should be installed in the line between the (customer-supplied) power supply and the alarm relay terminals on the Alarm Relay Assembly.
2. If the alarm contacts are connected to any device that produces radio frequency interference (RFI), it should be arc-suppressed. Rosemount Analytical Arc Suppression (PN 858728) is recommended.
3. If possible, the analyzer should operate on a different AC power source to avoid RFI.

4. Do not allow internal cable service loop to touch the detector assembly or associated inlet and outlet tubing. This precaution ensures against possible transmission of mechanical vibration through the cable to the detector, which can cause loss of accuracy.

ALARM RELAY CHARACTERISTICS

The ALARM 1 and ALARM 2. Outputs of the Alarm Relay Assembly are provided by two identical single-pole double-throw relays. Relay contacts are rated:

5 amperes	240	VAC resistive
1 ampere	240	VAC inductive
5 amperes	120	VAC resistive
3 amperes	120	VAC inductive
5 amperes	30	VDC resistive
3 amperes	30	VDC inductive

Removal of AC power from the analyzer, as in a power failure, de-energizes both relays, placing them in alarm condition. Switching characteristics of the ALARM 1 and ALARM 2 relays are as follows:

ALARM 1 Relay - The ALARM 1 relay coil is de-energized when the meter needle moves downscale through the value that corresponds to setpoint minus deadband. This relay coil is energized when the needle moves upscale through the value that corresponds to setpoint plus deadband. See Figure 2-5A.

ALARM 2 Relay - The ALARM 2 relay coil is de-energized when the meter needle moves upscale through the value that corresponds to the setpoint plus deadband. This relay coil is energized when needle moves downscale through the value that corresponds to setpoint minus deadband. See Figure 2-5B.

Alarm Reset - Normally both the ALARM 1 and ALARM 2 functions incorporate automatic reset. When the meter reading goes beyond the pre-selected limits, the corresponding relay is de-energized. When the meter reading returns within the acceptable range, the relay is automatically substituting an external pushbutton or other momentary-contact switch for the jumper that normally connects the RESET terminals on the Alarm Relay Assembly. If the corresponding relay is now de-energized, i.e., in alarm condition, the relay remains de-energized until the operator momentarily closes the switch.

Fail-Safe Applications - By appropriate connection to the double-throw relay contacts, it is possible to obtain either a contact closure or a contact opening for an energized relay. Also, either a contact closure or a contact opening may be obtained for a de-energized relay.

It is important that, for fail-safe applications, the user understand what circuit conditions are desired in the event of power failure and the resultant relay de-energization. Relay contacts should then be connected accordingly. Refer to Figure 2-6.

A. Typical ALARM 1 Setting

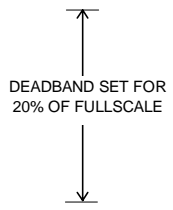

INPUT SIGNAL
Percent of Fullscale

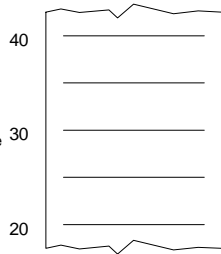

When input signal moves upscale through this point, the coil of ALARM 1 relay (K1) is energized, providing continuity between the common and normally-closed contacts of the relay.

← ALARM 1 Setpoint

When input signal moves downscale through this point, the coil of ALARM 1 relay (K1) is de-energized, providing continuity between the common and normally-open contacts of the relay.

B. Typical ALARM 2 Setting

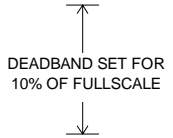

INPUT SIGNAL
Percent of Fullscale

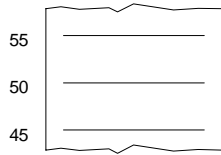

When input signal moves upscale through this point, the coil of ALARM 2 relay (K2) is de-energized, providing continuity between the common and normally-open contacts of the relay.

← ALARM 2 Setpoint

When input signal moves upscale through this point, the coil of ALARM 2 relay (K2) is energized, providing continuity between the common and normally-closed contacts of the relay.

FIGURE 2-5. TYPICAL ALARM SETTINGS

REQUIREMENT	TYPICAL CONNECTIONS	REQUIREMENT	TYPICAL CONNECTIONS
Low Alarm, Fail-Safe		Low Control Limit, Fail-Safe	
High Alarm, Fail-Safe		Lower Low Alarm Indicator, Fail-Safe	
Low Control Limit, Fail-Safe		Higher High Alarm Indicator, Fail-Safe	

FIGURE 2-6. RELAY TERMINAL CONNECTIONS FOR TYPICAL FAIL-SAFE APPLICATION

2.5 CALIBRATION GASES

2.5.1 ZERO CALIBRATION GAS

Zero-based range - Normally uses a oxygen-free gas, typically nitrogen.

Zero-suppressed range - Uses a blend consisting of a suitable percentage of oxygen contained in a background gas, typically nitrogen.

2.5.2 DOWNSCALE STANDARD GAS

Digital Display - Typically, although not necessarily, the downscale standard gas will be oxygen-free, such as nitrogen.

Recorder Readout - The downscale standard gas is selected to establish a calibration point at or near the lower range limit.

2.5.3 UPSCALE STANDARD GAS

Digital Display - Typically, the upscale standard gas will be a readily obtained gas such as dry air (20.93% oxygen) or 1005 oxygen.

Recorder Readout - A suitable upscale standard gas is required to establish a calibration point at or near the upper range limit. If this range limit is 21% or somewhat above 21%, the usual standard gas is dry air (20.93% oxygen).

2.6 SAMPLE HANDLING



CAUTION: PRESSURE LIMIT

Under no circumstances allow pressure to exceed 10 psig (69 kPa) as irreparable damage to the detector may result.

Many different sample handling systems are available, depending on the requirements of the individual user. Most sample handling systems have copper or brass components; however, stainless steel components are available for applications involving corrosive gases. With corrosive gases, complete drying of the sample is desirable, as most of these gases are practically inert when totally dry.

For specific corrosive applications, consult the factory.

2.6.1 SAMPLE TEMPERATURE REQUIREMENTS

Sample temperature at the analyzer inlet should be in the range of 50°F to 150°F (10°C to 66°C). With a thoroughly dry sample, entry temperature can be as high as 150°F (66°C) without affecting readout accuracy. Normally, a maximum entry temperature of 110°F (43°C) is recommended so that the sample temperature will rise

during passage of the sample through the analyzer. This precaution ensures against cooling of the sample and possible condensation of moisture. Such condensation should be avoided as it may damage the detector.

2.6.2. SAMPLE PRESSURE REQUIREMENTS: GENERAL

Operating pressure limits are the following: maximum, 10 psig (69 kPa gauge pressure); minimum, -1.9 psig (-13.1 kPa).



CAUTION: OPERATING LIMITS

Operation outside the specified limits may damage the detector and will void the warranty.

Oxygen readout is automatically corrected for atmospheric pressure variations within $\pm 3\%$ of the target value, which may be set anywhere within the range of -2.7 to 3.3 psig ± 3 psig (-18.6 to 22.8 kPa ± 21 kPa).

The basic rule for pressure of sample and standard gases supplied to the inlet is to calibrate the analyzer at the same pressure that will be used during subsequent operation and to maintain this pressure during operation. The arrangement required to obtain appropriate pressure control will depend on the application. Refer to special instructions included in Section 2.6.3, Normal Operation at Positive Gauge Pressures; or Section 2.6.4, Operation at Negative Gauge Pressures.

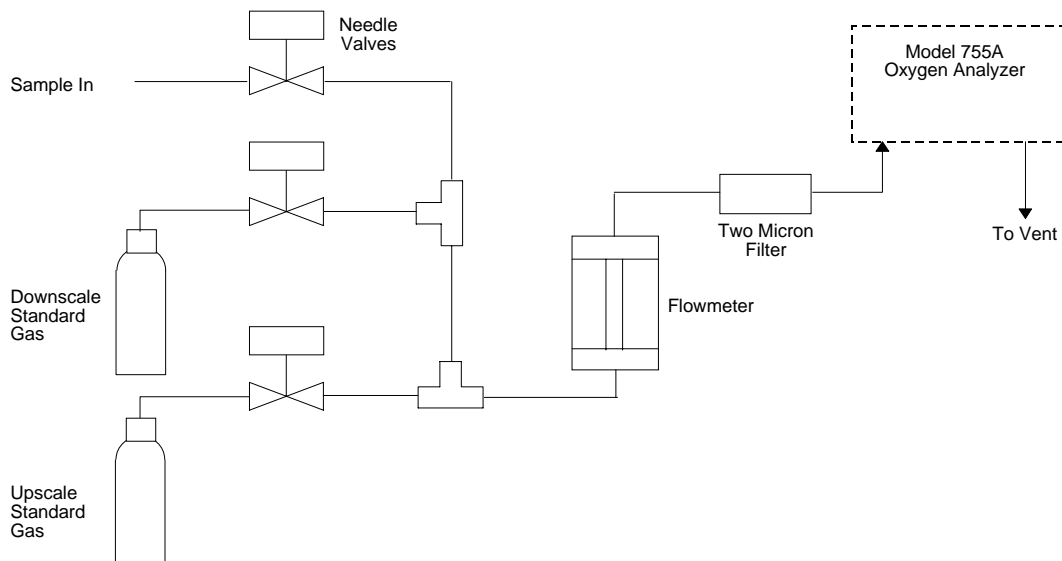

FIGURE 2-7. CONNECTION OF TYPICAL GAS SELECTOR PANEL TO MODEL 755A OXYGEN ANALYZER

2.6.3 NORMAL OPERATION AT POSITIVE GAUGE PRESSURES

Pressure at Sample Inlet (All Instruments) - Normally, the sample is supplied to the analyzer inlet at a positive gauge pressure in the range of 0 to 10 psig (0 to 69 kPa).



CAUTION: HIGH PRESSURE SURGES

High pressure surges during admission of sample or standard gases can damage the detector.

Sample Exhaust - The analyzer exhaust is vented directly to the atmosphere through an exhaust line with inner diameter sufficiently large as not to cause any back pressure. Internal circuitry automatically corrects the oxygen readout to within $\pm 1\%$ of fullscale for atmospheric pressure variations within $\pm 3\%$ of target value and within $\pm 2\%$ of fullscale for barometric pressure variations within $\pm 5\%$ of target value. The target value may be set anywhere within range of -2.7 to 3.3 psig ± 3 psig (-18.6 to 22.8 kPa ± 21 kPa).

2.6.4 OPERATION AT NEGATIVE GAUGE PRESSURES

Operation at negative gauge pressures is not recommended but may be used in certain special applications. A suction pump is connected to the analyzer exhaust port to draw sample into the inlet and through the analyzer. Such operation necessitates special precautions to ensure accurate readout. There is the basic consideration of supplying the standard gases to the analyzer at the same pressure that will be used for the sample during subsequent operation. In addition, any leakage will result in decreased readout accuracy as compared with operation at atmospheric pressure.

The minimum permissible operating pressure is -1.9 psig (-13.1 kPa). Operation below this limit may damage the detector and will void the warranty.

2.6.5 SAMPLE FLOW RATE

Operating limits for sample flow rate are the following: Minimum 50 cc/min.; maximum 500 cc/min. A flow rate of less than 50 cc/min. is too slow to sweep out the detector and associated flow system efficiently resulting in a slow system response. Too rapid a flow will cause a back pressure that will affect the reading. The optimum flow rate is between 200 and 300 cc/min.

Deviation from the set flow should be held to within $\pm 1\%$ or ± 2 cc/min, whichever is smaller. If so, zero and span drift will be within the limits given on the specifications page, provided that operating pressure remains constant.

Bypass Flow - Preferably the analyzer should be installed near the sample source to minimize transport time. Otherwise the time lag may be appreciable. For example, assume that sample is supplied to the analyzer via a 100 foot (30.5 m) length of 1/4

inch (6.35 mm) O.D. thin walled tubing. With a flow rate of 100 cc/min., sample transport time is approximately 6 minutes.

Sample transport time may be reduced by piping a greater flow than is required to the analyzer, then routing only the appropriate portion of the total flow through the analyzer. The unused portion of the sample may be returned to the stream or discarded.

2.6.6 CORROSIVE GASES

In applications where the sample stream contains corrosive gases, a complete drying of the sample is desirable, as most of these gases are practically inert when totally dry.

For corrosive applications, consult the factory.



WARNING: RADIOACTIVE SAMPLE GASES

Radioactive sample gases require the stainless steel tubing option.

2.7 LEAK TEST



WARNING: POSSIBLE EXPLOSION HAZARD

This analyzer is of the type capable of analysis of sample gases which may be flammable. If used for analysis of such gases, the instrument must be either in an explosion-proof enclosure suitable for the gas, or, protected by a continuous dilution purge system in accordance with Standard ANSI/NFPA-496 (Chapter 8) or IEC Publication 79-2-1983 (Section Three)

If explosive gases are introduced into this analyzer, the sample containment system must be carefully leak-checked upon installation and before initial start-up, during routine maintenance and any time the integrity of the sample containment system is broken, to ensure the system is in leak-proof condition.

Internal leaks resulting from failure to observe these precautions could result in an explosion causing death, personal injury and/or property damage.

Supply air or inert gas, such as nitrogen, at 10 psig (69 kPa) to analyzer via a flow indicator with range of 0 to 250 cc/min. Set flow at 125 cc/min. Plug sample outlet. Flow reading should drop to zero. If not, system is leaking.

Leaks must be corrected before introduction of flammable sample and/or application of electrical power. Liberally cover all fittings, seals, and other possible sources of

leakage with a suitable leak test liquid such as SNOOP (PN 837801). Bubbling or foaming indicates leakage. Checking for bubbles will locate most leaks but could miss some because some are inaccessible to application of SNOOP. For positive assurance that system is leak-free, use the flow stoppage test.

2.8 PURGE KIT (OPTIONAL)

The Purge Kit (PN 643108) is designed to equip the Model 755A with Type Z Air Purge per National Fire Protection Association Standard NFPA496-1986, Chapter 2¹.



WARNING: POSSIBLE EXPLOSION HAZARD

This analyzer is of the type capable of analysis of sample gases which may be flammable. If used for analysis of such gases, the instrument must be either in an explosion-proof enclosure suitable for the gas, or, protected by a continuous dilution purge system in accordance with Standard ANSI/NFPA-496 (Chapter 8) or IEC Publication 79-2-1983 (Section Three)

If explosive gases are introduced into this analyzer, the sample containment system must be carefully leak-checked upon installation and before initial start-up, during routine maintenance and any time the integrity of the sample containment system is broken, to ensure the system is in leak-proof condition.

Internal leaks resulting from failure to observe these precautions could result in an explosion causing death, personal injury and/or property damage.

The kit consists of the following:

PART NO.	DESCRIPTION
190697	Purge Inlet Fitting
645835	Purge outlet Fitting
082787	Warning Label
856156	Sealant (Duxseal)

Note:

To conform to NFPA Type Z requirements, the warning label must be applied to the analyzer front cover. If the analyzer is ordered factory equipped with the Purge Kit, this label is applied at the factory.

Installation options are shown in Figure 2-8. Use only clean dry air or suitable inert gas for the purge supply.

¹ These standards are not applicable to enclosures into which a flammable gas or vapor mixture is introduced, such as by a continuous sample containment system that is subject to accidental leakage.

Recommended supply pressure is 20 psig (138 kPa), which provides a flow of approximately 8 cubic feet per hour (4 liters per minute) and a case pressure of approximately 0.2 inch of water (50 Pa).

With a flow rate of 4 liters per minute, four case volumes of purge gas pass through the case in 10 minutes.

All conduit connections through the case must be sealed thoroughly with the sealant supplied in the kit. The sealant (applied from the interior of the case) must thoroughly cover all existing leads, as well as the conduit fitting.

A. Option with Flow Indicator

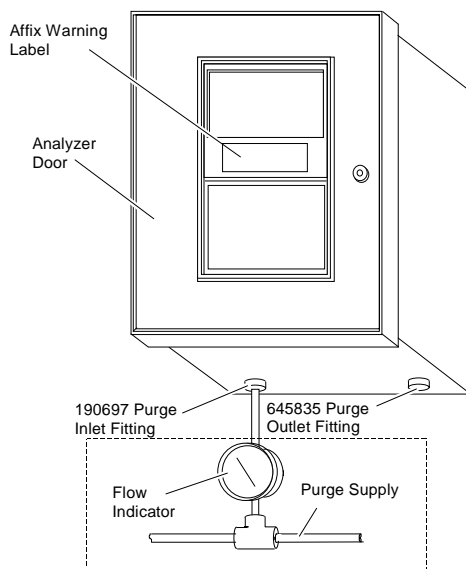

B. Option with Pressure Indicator or Alarm

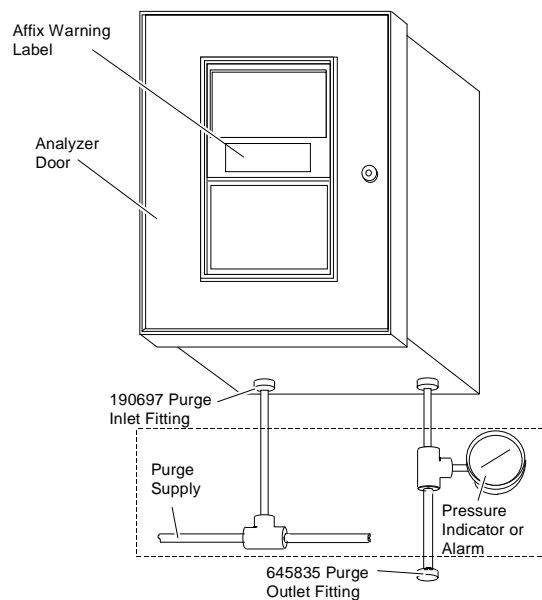

Components in dashed line are supplied by customer.

FIGURE 2-8. INSTALLATION OF PURGE KIT (OPTIONAL)

NOTES

3

INITIAL STARTUP AND CALIBRATION

Preparatory to startup and calibration, the operator should study Figures 3-1, 3-2, and Table 3-1. Together they give locations and summarized descriptions of operating controls and adjustments of the Model 755A.

3.1 SELECTION OF RECORDER OXYGEN RANGE

The digital display provides readout over the full range of 0.00% to 100.00% oxygen, eliminating the requirement for expanded-scale operation. With a recorder, however, resolution is normally limited to approximately 1% of fullscale. Thus, if the recorder output is to be the important display medium for the particular application, expanded-scale operation may be necessary to obtain the desired readout accuracy. Such operation is obtained by an appropriate combination of scale expansion and zero suppression.

3.1.1 RECORDER OXYGEN RANGE SELECTION PROCEDURE

Refer to Table 3-1 and Figure 3-2.

1. Verify that Recorder Voltage Output Jumper is in the position appropriate to the recorder: 10 mV, 100 mV, 1 V or 5 VDC.
2. Place the Recorder Oxygen Span Jumper in the position appropriate to the desired span. Note that on the circuit board switch positions are marked according to the *amplifier gain*.

Desired Oxygen Span for Recorder (%)	Amplifier Gain Marking on Board
100	1X
20	5X
10	10X
5	20X
2	50X
1	100X

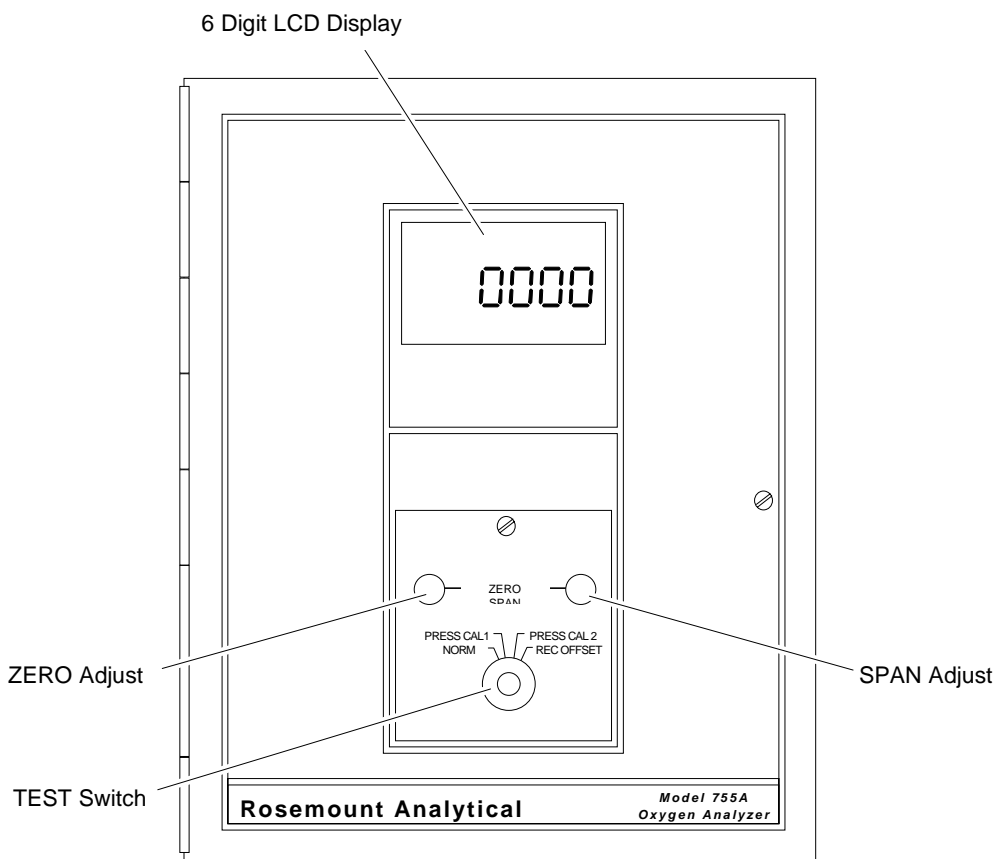

CONTROL	FUNCTION	
Digital Display (LCD)	Readout of sample oxygen content (0.00% to 100.00%) or selected test function, depending on position of TEST switch.	
TEST Switch (S1)	Selects variable desired for readout on digital display.	
	Switch Position	Designation
	1	NORM
	2	CAL 1
	3	CAL 2
	4	ZERO SUPPRESSION
ZERO Control (R13)	Used to establish downscale calibration point on digital display or recorder chart. With suitable downscale standard gas flowing through the analyzer, the ZERO Control is adjusted for appropriate reading on display.	
SPAN Control (R16)	Used to establish upscale calibration point on digital display or recorder chart. With suitable upscale standard gas flowing through the analyzer, the SPAN Control is adjusted for appropriate reading on display or recorder.	

FIGURE 3-1. MODEL 755A FRONT PANEL CONTROLS

3. Select the required zero suppression by appropriate settings of the following:
 - a. Set Recorder Zero Suppression Jumper for fixed value of 0%, 20%, 40%, 60% or 80% oxygen.
 - b. Set Recorder Zero Suppression Coarse Adjustment R41 for appropriate value in the range of 05 to 25% oxygen.

Note:

The actual applied zero suppression may be measured and established via readout on the digital display per the procedure of Section 3.1.2.

Example 1, Selection of a Zero-Based Recorder Output Range:

- Desired oxygen range for recorder output: 0 to 100%.
- Required span of 100% oxygen is selected when Recorder Oxygen Span Jumper is in the 1X position.
- Required Zero Suppression is 0%, thus Recorder Zero Suppression Jumper, is removed, and R41, Recorder Zero Suppression Coarse Adjustment, and R104, Recorder Zero Suppression Fine Adjustment, are adjusted for 0% oxygen.

Note:

The Zero and Span adjustments on the analyzer door are used only for the calibration of the digital readout for 0 to 100% oxygen.

The suppressed recorder ranges may only be set up after the digital readout has been calibrated. When setting up a suppressed recorder range, use only R41, R104 (setpoint) and R88 (Span) for adjustments. DO NOT RE-ADJUST THE ZERO AND SPAN CONTROLS ON THE ANALYZER DOOR.

Example 2, Selection of a Zero-Suppressed Recorder Oxygen Range.

- Desired oxygen range for recorder output: 90% to 100%.
- Required span of 10% oxygen (100% - 90%) is selected when Recorder Oxygen Span Jumper is placed in the 10X gain position.
- Required zero suppression is 90% oxygen, thus Recorder Zero Suppression Jumper, is placed in 80% position, the highest setting below the zero suppression level, and R41, Recorder Zero Suppression Coarse Adjustment, and R104, Recorder Zero Suppression Fine Adjustment, are adjusted for the additional 10% required to reach the desired zero suppression level (90% desired level - 80% zero suppression Jumper).

INITIAL STARTUP AND CALIBRATION

ITEM	CONTROL	DESCRIPTION
1	Recorder Oxygen Span Selection Jumper	Provides selectable span of 100%, 20%, 10%, 5%, 2%, or 1% oxygen for analog output to recorder and alarms. Note that on the circuit board the jumper positions are marked according to the amplifier gain.
2	Recorder Zero Suppression Selection Jumper	Used in combination with item 3 to establish required zero suppression to obtain desired range for analog output to recorder and alarms. Jumper provides selectable zero suppression of 20%, 40%, 60%, or 80%
3	Recorder Zero Suppression Coarse Adjustment R41	Continuously adjustable from 0% to 25% oxygen. Thus the total suppression range is 0% to 105% oxygen.
4	Recorder Zero Suppression Fine Adjustment R104	Adjustable range of 2%.
5	Recorder Voltage Output Selection Jumper	Provides selectable output of 10mV, 100mV, 1V or 5V for a voltage recorder.
6	Recorder Span Adjustment R88	Provides $\pm 5\%$ span adjustment of recorder output.
7	CAL 1 Potentiometer R98	Used in calibration of automatic pressure compensation.
8	CAL 2 Potentiometer R99	Used in calibration of automatic pressure compensation.
9	Detector Coarse Zero Adjustment R9	Provides coarse adjustment of detector zero by shifting the null position of the detector within the magnetic field. It is adjusted at the factory and does not require readjustment except after replacement of detector.
10	Response Time Adjustment R30	Provides adjustment range of 5 to 25 seconds for electronic response time (0 to 90% of fullscale). Adjusting clockwise decreases response time.
11	Response Ratio Timing Potentiometer R29	Permits compensation for slight gain changes that may result from adjustment of R20. At the factory, R29 is adjusted to establish the exact resistance ratio required and is then secured with locking compound.
12	ALARM 2 Calibration Adjustment R67	Used for initial calibration of ALARM 2 circuit.
13	ALARM 2 Setpoint Adjustment R68	Provides continuously variable adjustment of setpoint for ALARM 2 circuit on alarm accessory, for actuation of external, customer supplied alarm and/or control device(s). Adjustment range is 0 to 100% of fullscale span.
14	ALARM 2 Deadband Adjustment R78	Permits adjusting deadband of ALARM 2 circuit from 1% of fullscale (counterclockwise limit) to 20% of fullscale (clockwise limit). Deadband is essentially symmetrical with respect to setpoint.
15	ALARM 1 Calibration Adjustment R63	See item 12 above.
16	ALARM 1 Setpoint Adjustment R64	See item 13 above.
17	ALARM 1 Deadband Adjustment R73	See item 14 above.
8	Current Output Zero Adjustment R1	Use to set zero-level current output, i.e., 4mA for 4 to 20mA board, 0mA for 0 to 20mA board.
19	Current Output Span Adjustment R2	Use to set fullscale current output at 20mA for 4 to 20mA or 0 to 20mA board or at 50mA for 10 to 50mA board.

Refer to Figure 3-2 for component locations.

TABLE 3-1. MODEL 755A INTERNAL ADJUSTMENTS

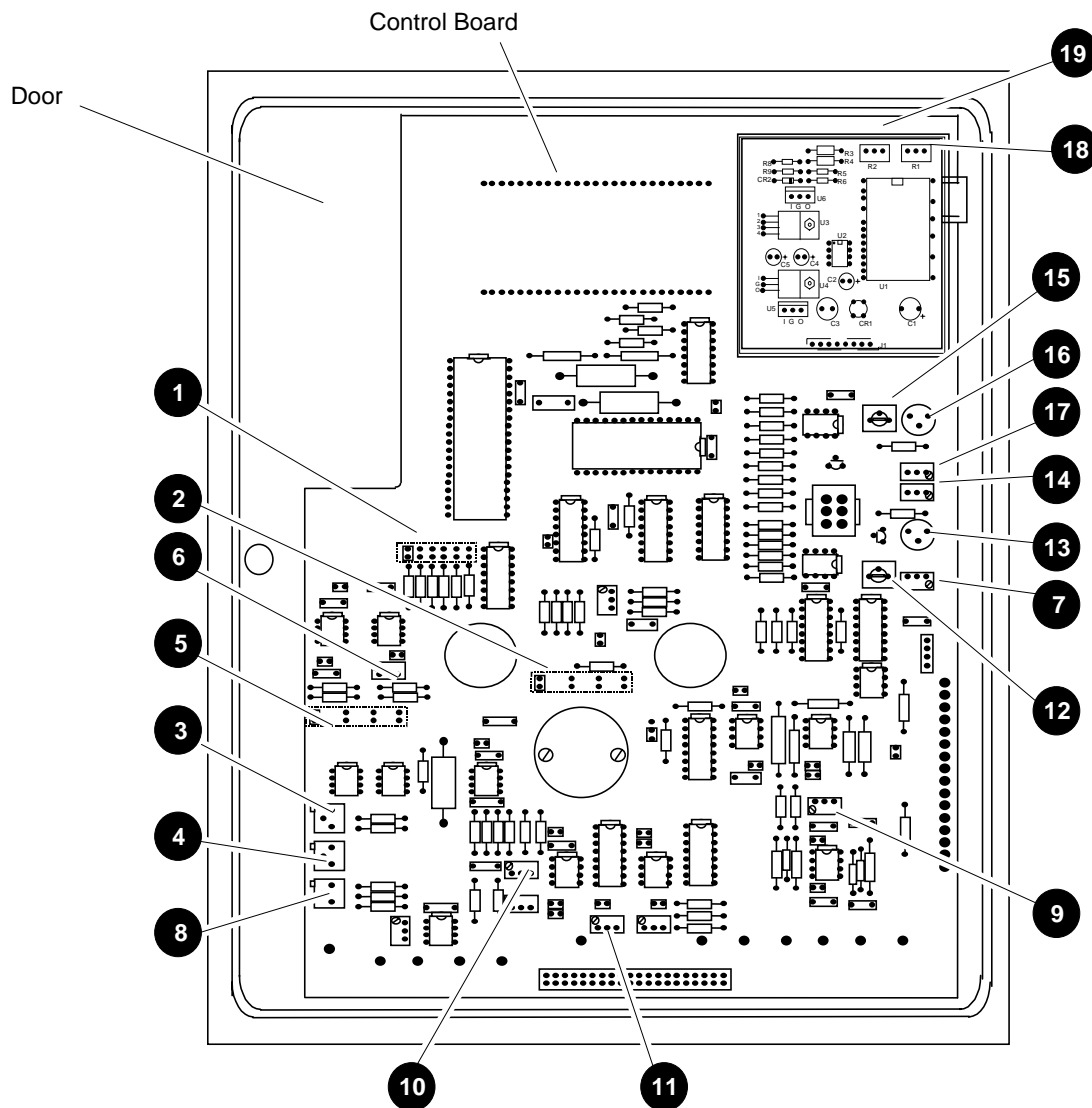

Refer to Table 3-1 for descriptions.

FIGURE 3-2. MODEL 755A INTERNAL ADJUSTMENTS LOCATIONS

3.1.2 READOUT OF APPLIED ZERO-SUPPRESSION VOLTAGE ON DIGITAL DISPLAY

In order to establish the precise zero suppression required for the desired recorder oxygen range, the actual applied zero suppression voltage may be read on the digital display.

PROCEDURE:

1. Verify that Recorder Voltage Output Jumper is in the position appropriate to the recorder: 10 mV, 100 mV, 1 V or 5 VDC.
2. Place the front panel TEST switch in position 4, thus disconnecting the signal input to permit display of the zero-suppression voltage only.
3. Temporarily place Recorder Oxygen Span Jumper in 100% oxygen (i.e., 1X gain) position. The digital display will now read the applied zero suppression voltage in

the range of 0.00 volt (equivalent to 0% oxygen) to 10.00 volts (equivalent to 100% oxygen).

4. Obtain the required zero suppression by appropriate combination of settings on the Recorder Zero Suppression Jumper and Recorder Zero Suppression Adjustments R41 and R104, as indicated by an exactly correct reading on the digital display.
5. Return the Recorder Oxygen Span Jumper to the normal operating position for the selected range.
6. Set the front panel TEST switch to position 1.

Example: With a highly expanded scale such as the 99% to 100% oxygen range of this example, a slight readjustment of R104 may be required to set the recorder pen at the precisely correct position on the chart.

- Desired oxygen range for recorder output: 99% to 100%.
- Front panel TEST switch is set to position 4, and Recorder Oxygen Span Jumper is placed in 100% oxygen (1X gain) position.
- Required zero suppression is 99% oxygen, thus Recorder Zero Suppression Jumper is set in 80% position, and Recorder Zero Suppression Adjustments R41 and R104 are set for a reading of 99.00 volts on the digital display.
- Recorder Oxygen Span Jumper is returned to 1% oxygen (100X gain) position, normal span setting for 99% to 100% oxygen range. R88 may be used for fine span adjustment.
- Set front panel TEST switch to position 1.

3.2 STARTUP PROCEDURE



WARNING: POSSIBLE EXPLOSION HAZARD

If gases are introduced into this analyzer, the sample containment system must be carefully leak-checked upon installation and before initial start-up, during routine maintenance and any time the integrity of the sample containment system is broken, to ensure the system is in leak-proof condition. Leak-check instructions are provided in Section 2.7.

Internal leakage of sample resulting from failure to observe these precautions could result in an explosion causing death, personal injury, or property damage.

Pass suitable on-scale gas (not actual sample) through the analyzer. Turn power ON. If digital display gives over-range indication, the probable cause is hang-up of the suspension within the detector assembly. To correct this condition, turn power OFF; tap detector compartment with fingers; wait 30 seconds; re-apply power.

When on-scale reading is obtained, allow analyzer to warm up for at least one hour with gas flowing. This warm-up is necessary because a reliable calibration is obtainable only after the analyzer reaches temperature stability. Moreover, the resultant elevated temperature will ensure against condensation within, and possible damage to the detector assembly.

After analyzer warm-up, the digital display or recorder should give stable, drift-free readout; if so, proceed to Section 3.3. Otherwise refer to Section 7, Routine Service and Maintenance.

3.3 CALIBRATION

Calibration for oxygen readout consists of establishing a downscale and upscale point.

3.3.1 CALIBRATION USING DIGITAL READOUT FOR OXYGEN READOUT

The digital display covers the full range of 0.00% to 100.005 oxygen and thus will normally be used as the readout device during calibration. If so, almost any downscale and upscale standards may be used. Typically the downscale standard will be an oxygen-free gas such as nitrogen, and the upscale standard will be some readily obtained gas such as dry air (20.93% oxygen) or 100% oxygen. Purity requirements will be dictated by the accuracy requirements of the application.

3.3.2 CALIBRATION USING RECORDER FOR OXYGEN READOUT

In some applications the recorder readout may be the important display and may thus be used during calibration. If so, the down-scale standard gas is selected to establish a calibration point at or near the lower range-limit of the selected range:

1. A zero-based range normally uses an oxygen-free gas, typically nitrogen.
2. A zero-suppressed range uses a blend consisting of a suitable percentage of oxygen contained in a background gas, typically nitrogen.

The upscale standard gas is required to establish a calibration point at or near the upper range limit. For example, if this range limit is 21% (or somewhat greater than 21%), the usual upscale standard gas is dry air (20.93% oxygen).

Typical examples of standard gases for recorder oxygen ranges are shown in Table 3-2.

A. TYPICAL ZERO-BASED RANGES

0 to 1	Nitrogen	0.9% O ₂	Balance N ₂
0 to 10	Nitrogen	9% O ₂	Balance N ₂
0 to 100	Nitrogen	100% O ₂	

B. TYPICAL ZERO-SUPPRESSED RANGES

RANGE % O ₂	RECOMMENDED STANDARD GAS	RECOMMENDED UPSCALE STANDARD GAS
20 to 21	20.2% ±0.2% O ₂	Air (20.93% O ₂)
11 to 21	11.2% ±0.2% O ₂ Balance N ₂	Air (20.93% O ₂)
99 to 100	High Purity O ₂ with 0.8% ±0.05% High Purity N ₂	High Purity O ₂
90 to 100	91% ±0.5% O ₂ Balance N ₂	High Purity O ₂

Note: Each standard gas used should have a composition within the specified limits and should have a certified analysis provided by the supplier.

TABLE 3-2. STANDARD GASES RECOMMENDED FOR CALIBRATION OF VARIOUS OXYGEN RANGES ON ANALOG OUTPUT

3.3.3 CALIBRATION WITH DOWNSCALE AND UPSCALE STANDARD GASES

1. Set downscale calibration point as follows:
 - a. Set TEST switch (on analyzer door) to NORM.
 - b. Pass downscale standard gas through analyzer at suitable flow rate, preferably 250 cc/min. Allow gas to purge analyzer for minimum of 3 minutes.

Note:

The Zero and Span adjustments on the analyzer door are used only for the calibration of the digital readout for 0 to 100% oxygen.

The suppressed recorder ranges may only be set up after the digital readout has been calibrated. When setting up a suppressed recorder range, use only R41, R104 (setpoint) and R88 (Span) for adjustments. DO NOT RE-ADJUST THE ZERO AND SPAN CONTROLS ON THE ANALYZER DOOR.

- c. Adjust ZERO Control so that the reading on the digital display or recorder is appropriate to the downscale standard gas. (The required reading may be the actual oxygen content of the downscale standard gas or may be an adjusted value, depending on the relative magnetic susceptibilities involved. Refer to Section 3.4.2). If proper reading is not obtained by an adjustment of the ZERO Control, refer to Section 6, Routine Servicing.
2. Set upscale calibration point as follows:
 - a. Verify that front panel TEST switch is set to NORM.

- b. Pass upscale standard gas through analyzer at same flow rate as was used for downscale standard gas. Allow gas to purge analyzer for minimum of 3 minutes.
- c. Adjust SPAN Control so that reading on digital display or recorder is appropriate to the upscale standard gas. (The required reading may be the actual oxygen content of the upscale standard gas or may be an adjusted value, depending on the relative magnetic susceptibilities involved. Refer to Section 3.4.2). If proper reading is unobtainable by adjustment of the SPAN control, refer to Section 6, Routine Servicing.

Repeat steps 1 and 2 to ensure no interaction has occurred.

3.3.4 CALIBRATION OF AUTOMATIC PRESSURE COMPENSATION

Oxygen readout is automatically corrected to within $\pm 1\%$ of fullscale for barometric pressure variations within $\pm 3\%$ of the target value and is corrected to within $\pm 2\%$ of fullscale for variations within $\pm 5\%$ of the target value. The target value may be set anywhere within the range of -2.7 to 3.3 psig ± 3 psig (-18.6 to 22.8 kPa ± 21 kPa). The factory setting is 0 psig (0 kPa). This setting is suitable for applications where (a) the analyzer exhaust port is vented directly to the atmosphere, and (b) the installation site is at or near sea level. If conditions are otherwise, the pressure compensation circuit must be re-calibrated by the following procedure:

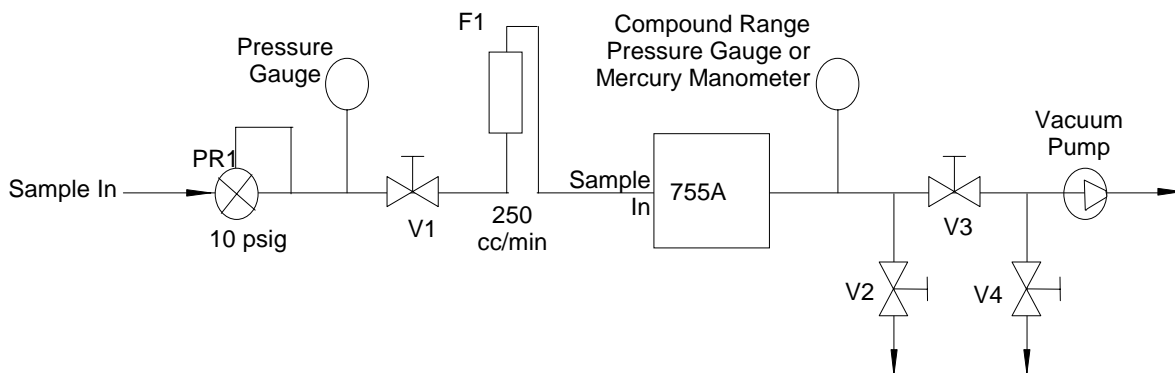

FIGURE 3-3. CALIBRATION BY PRESSURE DECREASE SETUP

STANDARD PROCEDURE: CALIBRATION BY PRESSURE DECREASE

1. Verify that the Pressure Compensation Option is selected, i.e., Jumper inserted between E1 and E3 on the Control Board.
2. Connect a compound range pressure gauge (or mercury manometer), pressure gauge, pressure regulator, flowmeter, needle valves and vacuum pump as shown in Figure 3-3.
3. Open V2, set PR1 to approximately 10 psig (69 kPa) and adjust V1 for a flow rate of 250 cc/min. into the sample inlet line. Compound range pressure gauge (or mercury manometer) should indicate close to atmospheric pressure (0.00).
4. Set TEST switch to PRESS CAL 1 and adjust CAL 1 potentiometer R98 (see Table 3-1, Figure 3-2) for a reading of 00.00 ± 5 counts on the display.
5. Set TEST switch to NORM and note display reading.
6. Start vacuum pump.
7. Close V2 and adjust V3 and V4 to decrease the pressure on the sample exhaust by about 3%. (-12.00 inches of water; -0.4 psi; -23 mm of mercury; -3 kPa).
8. Adjust CAL 2 potentiometer R99 (see Table 3-1, Figure 3-2) until reading on display is the same noted in step 5.
9. Repeat steps 3 through 7 as many times as necessary to ensure repeatability of compensation calibration.

Note

Although not mandatory, it is desirable, in order to obtain maximum accuracy, that the oxygen concentration of the gas used during calibration be close to that of the process stream which is to be analyzed.

3.4 COMPENSATION FOR COMPOSITION OF BACKGROUND GAS

Any gas having a compensation other than 100% oxygen contains background gas. The background gas comprises all non-oxygen constituents.

Although instrument response to most gases other than oxygen is comparatively slight, it is not in all cases negligible. Contribution of these components to instrument response can be computed for each individual case.

If the downscale and upscale standard gases contain the same background gas as the sample, the routine standardization procedure automatically compensates for the background components; therefore, they introduce no error. If the background gas in the sample is different from that in the downscale and/or upscale standard gas(es), however, background effects must be taken into consideration to ensure correct readout.

During adjustment of the ZERO and SPAN controls (on the analyzer door), the instrument is set to indicate, not the true oxygen content of the downscale and

upscale standard gases, but slightly different values calculated to provide correct readout during subsequent analysis of the sample gas. The calculations are explained in Section 3.4.2.

3.4.1 OXYGEN EQUIVALENT VALUES OF GASES

For computation of background corrections, the analyzer response to each component of the sample must be shown. Table 3-2 lists the percentage oxygen equivalent values for many common gases.

The percentage oxygen equivalent of a gas is the instrument response to the given gas compared to the response to oxygen, assuming that both gases are supplied at the same pressure .

In equation form: %O₂ Equivalent of Gas

$$\frac{\text{Analyzer Response to Gas}}{\text{Analyzer Response to O}_2} \times 100$$

To select a random example from Table 3-3, if analyzer response to oxygen is +100%, the response to xenon would be -1.34%.

OXYGEN EQUIVALENTS OF GAS MIXTURES

The oxygen equivalent of a gas mixture is the sum of the contribution of the individual gas components.

Example: At lower range limit, i.e., 0% oxygen, composition of sample is 80% CO₂, 20% N₂.

From Table 3-3, the % oxygen equivalents are CO₂, -0.623 and N₂, -0.358.

% oxygen equivalent of the mixture =

$$0.8 \times (-0.623) + 0.2 \times (-0.358) = (-0.4984) + (-0.0716) = -0.570$$

3.4.2 COMPUTING ADJUSTED SETTINGS FOR ZERO AND SPAN CONTROLS

During instrument calibration, Adjusted Values may be required in setting the ZERO and SPAN control to correct for the magnetic susceptibility of the background gas. Terms used in the equation are defined as:

1. Std. Oxygen equivalent of background gas in the standard. Refer to Table 3-3.
2. Spl. Oxygen equivalent of background gas in the sample. Refer to Table 3-3 for values.

Calibration and measurement must be made at the same pressure in the detector cell unless the user makes the compensation referred to in Section 4.2.

$$\text{Adjusted value} = \% \text{ O}_2 \text{ in Std} + \frac{\% \text{ O}_2 \text{ in Std}}{100} \frac{[100(\text{Spl-Std})]-100(\text{Spl-Std})}{100}$$

Example:

Sample is oxygen in a background of CO₂. (Oxygen equivalent of CO₂ is -0.623).

Standard is the following:

Pure nitrogen for ZERO gas.

21% oxygen, 79% nitrogen for SPAN gas. (Oxygen equivalent of nitrogen is -0.358).

With nitrogen ZERO gas flowing, Adjusted Value is the following:

$$0 + \frac{\frac{0}{100} [100((-0.623)-(-0.358))] - 100((-0.623)-(-0.358))}{100} = \frac{0 - 100(-0.265)}{100} = 0.265$$

Display should be made to read 0.265% oxygen with ZERO control.

With SPAN gas (21% oxygen, 79% nitrogen) flowing, Adjusted Value is the following:

$$21 + \frac{\frac{21}{100} [100((-0.623)-(-0.358))] - 100((-0.623)-(-0.358))}{100} = 21 + \frac{0 - 211(-26.5) - (-26.5)}{100} + \frac{-5.565 + 26.5}{100} = 21.21\%$$

Display should be made to read 21.21% oxygen with SPAN control.

In limiting cases the general equation reduces to simpler forms:

1. If the SPAN gas is 100% oxygen, there is no background gas and thus no correction.
2. If the ZERO gas is oxygen-free, the adjusted value for setting the ZERO control becomes -((-0.623)-(-0.358)). When the ZERO gas is more diamagnetic than the background gas in the sample, this difference is negative. Use a recorder with below-zero capability to set negative values.

GAS	EQUIV. % AS O ₂
Acetylene, C ₂ H ₂	-0.612
Allene, C ₃ H ₄	-0.744
Ammonia, NH ₃	-0.479
Argon, A	-0.569
Bromine, Br ₂	-1.83
1,2-Butadiene C ₄ H ₆	-1.047
1,3-Butadiene C ₄ H ₆	-1.944
n-Butane, C ₄ H ₁₀	-1.481
iso-Butane, C ₄ H ₁₀	-1.485
Butene-1, C ₄ H ₈	-1.205
cis Butene-2, C ₄ H ₈	-1.252
iso-Butene, C ₄ H ₈	-1.201
trans butene-2, C ₄ H ₈	-1.274
Carbon Dioxide CO ₂	-0.623
Carbon Monoxide, CO	-0.354
Ethane, C ₂ H ₆	-0.789
Ethylene, C ₂ H ₄	-0.553
Helium, He	-0.059
n-Heptane, C ₇ H ₁₆	-2.508
n-Hexane, C ₆ H ₁₂	-2.175
cyclo-Hexane, C ₆ H ₁₂	-1.915
Hydrogen, H ₂	-0.117
Hydrogen Bromide, Hbr	-0.968
Hydrogen Chloride, HC1	-0.651
Hydrogen Fluoride, HF	-0.253
Hydrogen Iodide, HI	-1.403
Hydrogen Sulphide, C ₂ S	-0.751
Krypton, Kr	-0.853
Methane, CH ₄	-0.512
Neon, Ne	-0.205
Nitric Oxide, NO	+44.2
Nitrogen, N ₂	-0.358
Nitrogen Dioxide, NO ₂	+28.7
n-Octane, C ₈ H ₁₈	-2.840
Oxygen, O ₂	+100.0
n-Pentane, C ₅ H ₁₂	-1.810
iso-Pentane, C ₅ H ₁₂	-1.853
neo-Pentane, C ₅ H ₁₂	-1.853
Propane, C ₃ H ₈	-1.135
Propylene, C ₃ H ₆	-0.903
Water, H ₂ O	-0.381
Xenon, Xe	-1.340

TABLE 3-3. OXYGEN EQUIVALENTS OF COMMON GASES

3.5 DUAL ALARM OPTION

3.5.1 INITIAL CALIBRATION AND SELECTION OF SETPOINTS FOR ALARMS

The ALARM 1 and ALARM 2 circuits have independent setpoint and deadband adjustments (Table 3-1, Figure 3-2). Initially the ALARM 1 and ALARM 2 setpoint adjustments must be calibrated by means of the ALARM 1 and ALARM 2 calibration adjustments.

1. Set TEST switch to NORM.
2. Pass upscale standard gas through the analyzer at a flow rate of 50 to 500 cc/min.
3. Verify that ALARM 1 and ALARM 2 deadband adjustments are fully counterclockwise to set deadband at minimum. Normally these potentiometers are factory-set for minimum deadband. Both potentiometers must remain at this setting throughout calibration of the alarm setpoints.

CALIBRATION OF ALARM 1, HIGH:

1. Rotate setpoint adjustment R64 full counterclockwise.
2. Adjust SPAN control to obtain a display or recorder reading exactly fullscale. If the fullscale setting cannot be reached, then set to a reading higher than the desired alarm setpoint.
3. Set ALARM 1 calibration adjustment, R63, to its clockwise limit. Turn R63 counterclockwise the minimum required to energize ALARM 1 (relay K1, Figure 3-4). Energization may be verified by connecting an ohmmeter to relay terminals on 638254 Alarm Relay Assembly (Figure 2-1).

CALIBRATION OF ALARM 2, LOW:

1. Rotate setpoint potentiometer R67 full counterclockwise.
2. Adjust SPAN control to obtain a display or recorder reading exactly fullscale. . If the fullscale setting cannot be reached, then set to a reading higher than the desired alarm setpoint.
3. Set ALARM 1 calibration adjustment, R67, to its clockwise limit. Turn R63 counterclockwise the minimum required to energize ALARM 1 (relay K1, Figure 3-4). Energization may be verified by connecting an ohmmeter to relay terminals on 638254 Alarm Relay Assembly (Figure 2-1).

SETPOINT OF ALARM 1, HIGH

1. With span gas flowing, adjust SPAN Control to read desired alarm setpoint on display or recorder.
2. Turn setpoint adjustment, R64, clockwise to energy relay.

3. Check this setting by adjusting the SPAN Control to lower the output below the setpoint. This will re-energize the relay. Turning R64 above the setpoint will energize the relay.

SETPOINT OF ALARM 2, LOW

1. With span gas flowing, adjust SPAN Control to read desired alarm setpoint on display or recorder.
2. Turn setpoint adjustment, R68, clockwise to energy relay.
3. Check this setting by adjusting the SPAN Control to lower the output below the setpoint. This will re-energize the relay. Turning R68 above the setpoint will energize the relay.

3.5.2 SELECTION OF DEADBAND

The desired deadband may be selected with the appropriate trimming potentiometer:

ALARM 1 = R73

ALARM 2 = R78

For any setpoint, deadband is adjustable from 1% of fullscale (counterclockwise limit) to 20% of fullscale (clockwise limit). Deadband is essentially symmetrical with respect to setpoint.

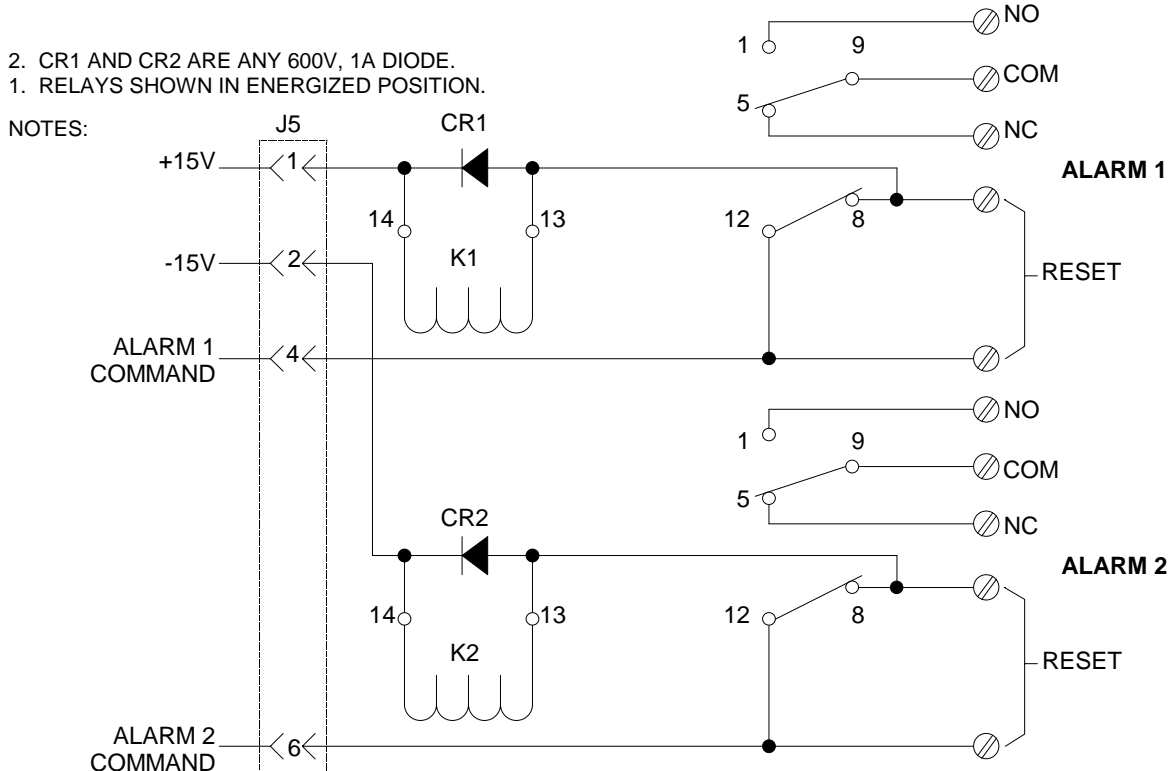

FIGURE 3-4. SCHEMATIC CIRCUIT OF ALARM RELAY ASSEMBLY

4 ROUTINE OPERATION

4.1 ROUTINE OPERATION

After the calibration procedure of Section 3.3, admit sample gas to the analyzer at the same pressure and the same flow rates used for the zero and span gases. The instrument will now continuously indicate the oxygen content of the sample gas.

At this time, an adjustment of electronic response time (R30 on the Control Board, see Table 3-1, Figure 3-2), may be desirable to obtain the optimum compromise between response speed and noise.

4.2 EFFECT OF BAROMETRIC PRESSURE CHANGES ON INSTRUMENT READOUT

If the analyzer exhaust port is vented through a suitable absolute backpressure regulator, and the installation site is at or near sea level, barometric pressure changes do not affect the percent oxygen readout. If conditions are otherwise, the pressure compensation circuit must be re-calibrated per Section 3.3.4.

4.3 CALIBRATION FREQUENCY

The appropriate calibration interval will depend on the accuracy required in the particular application, and is best determined by keeping a calibration log.

NOTES

5.1 PRINCIPLES OF OPERATION

Oxygen is strongly paramagnetic while most other common gases are weakly diamagnetic. The paramagnetism of oxygen may be regarded as the capability of an oxygen molecule to become a temporary magnet when placed in a magnetic field. This is analogous to the magnetization of a piece of soft iron. Diamagnetic gases are analogous to non-magnetic substances.

With the Model 755A, the volume magnetic susceptibility of the flowing gas sample is sensed in the detector/magnet assembly. As shown in the functional diagram of Figure 5-2, a dumbbell-shaped, nitrogen-filled, hollow glass test body is suspended on a platinum/nickel alloy ribbon in a non-uniform magnetic field.

Because of the “magnetic buoyancy” effect, the spheres of the test body are subjected to displacement forces, resulting in a displacement torque that is proportional to the volume magnetic susceptibility of the gas surrounding the test body.

Measurement is accomplished by a null-balance system, where the displacement torque is opposed by an equal, but opposite, restorative torque. The restorative torque is due to electromagnetic forces on the spheres, resulting from a feedback current routed through a titanium wire conductor wound lengthwise around the dumbbell.

In effect, each sphere is wound with a one-turn circular loop. The current required to restore the test body to null position is directly proportional to the original displacement torque, and is a linear function of the volume magnetic susceptibility of the sample gas.

The restoring current is automatically maintained at the correct level by an electro-optical feedback system. A beam of light from the source lamp is reflected off the square mirror attached to the test body, and onto the dual photocell.

The output current from the dual photocell is equal to the difference between the signals developed by the two halves of the photocell. This difference, which constitutes the error signal, is applied to the input of an amplifier circuit that provides the restoring current.

When the test body is in null position, both halves of the photocell are equally illuminated, the error signal is zero, and the amplifier is unequal. As soon as the test

body begins to rotate, the amounts of light becomes unequal, resulting in application of an error signal to the input of the amplifier circuit. The resultant amplifier output signal is routed through the current loop, thus creating the electromagnetic forces required to restore the test body to null position.

MAGNETIC DISPLACEMENT FORCE

Because the magnetic forces on the spherical ends of the test body are the basis of the oxygen measurement, it is worthwhile to consider the force acting on one of these spheres alone and to disregard, for the present, the remainder of the detector. A small sphere suspended in a strong non-uniform magnetic field, Figure 5-1, is subjected to a force proportional to the difference between the magnetic susceptibility of this sphere and that of the surrounding gas.

Magnitude of the force is expressed by the following (simplified) equation:

$$F_k = c (k - k_0)$$

Where:

c = A function of the magnetic field strength and gradient

k = Magnetic susceptibility of the surrounding gas

k_0 = Magnetic susceptibility of the sphere

The forces exerted on the two spheres of the test body are thus a measure of the magnetic susceptibility of the sample and, therefore, of its oxygen content.

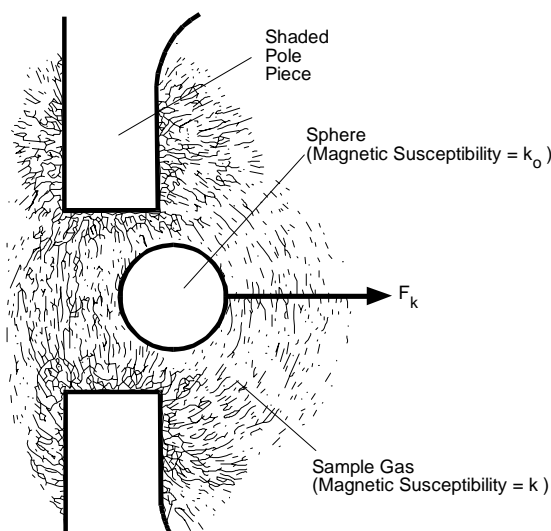

Note:
As percentage of oxygen in sample gas increases,
displacement force (F_k) increases.

FIGURE 5-1. SPHERICAL BODY IN NON-UNIFORM MAGNETIC FIELD

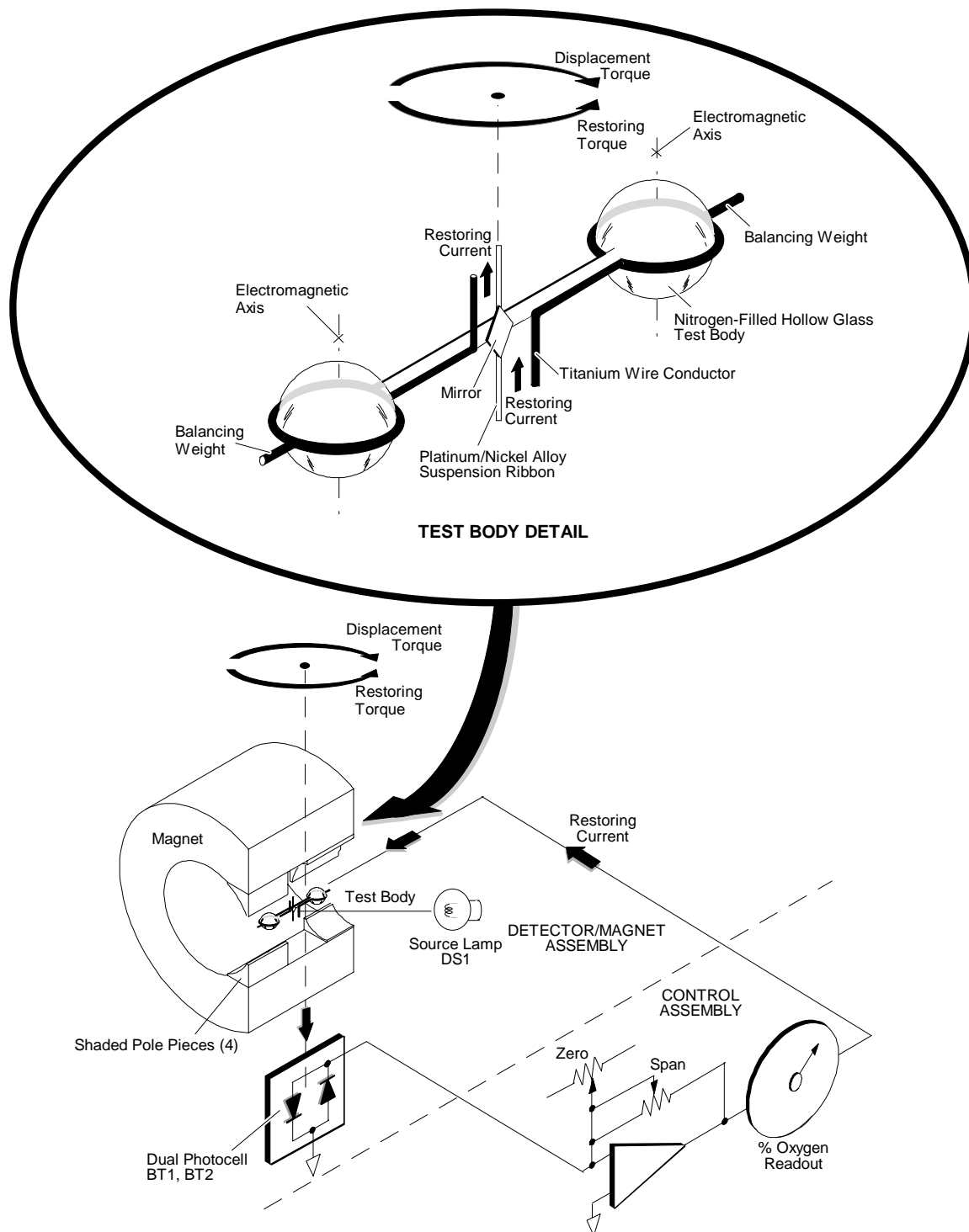
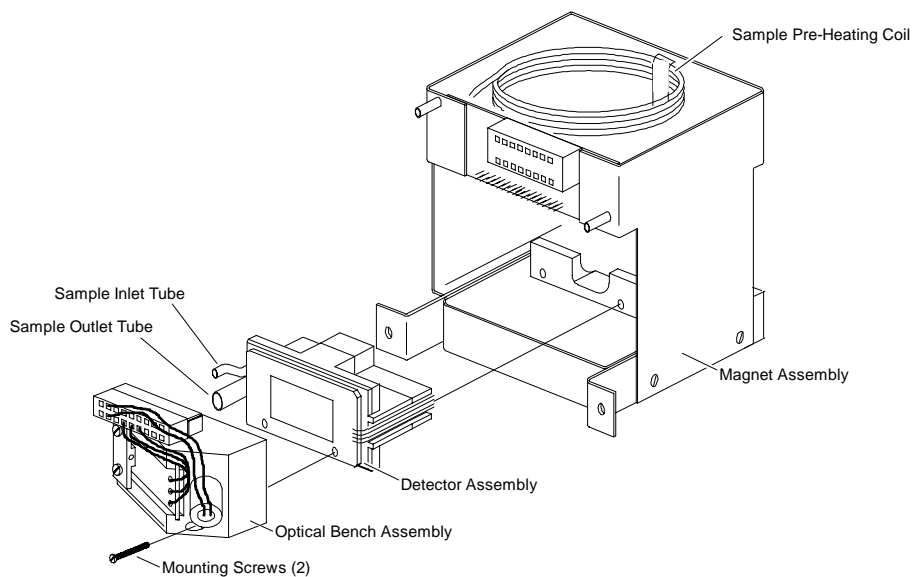
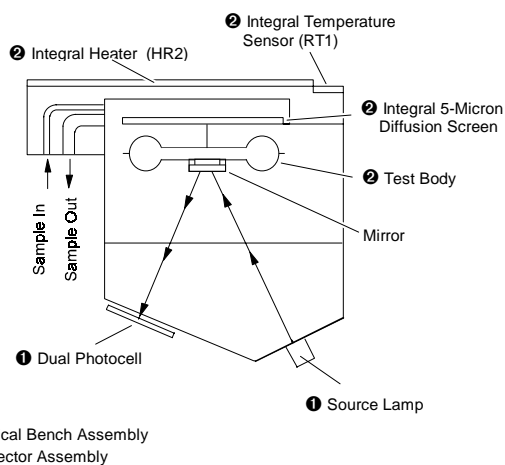

FIGURE 5-2. FUNCTIONAL DIAGRAM OF MODEL 755A PARAMAGNETIC OXYGEN MEASUREMENT SYSTEM



A. Exploded View of Detector/Magnet Assembly



B. Sectional Top View of Optical Bench and Detector Assemblies

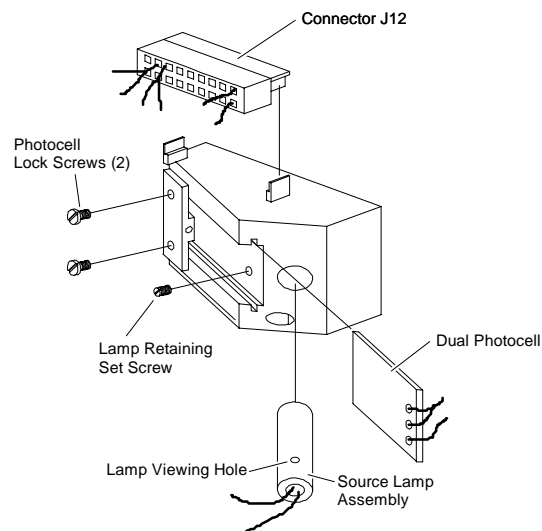

C. Exploded View of Optical Bench Assembly

FIGURE 5-3. DETECTOR/MAGNET ASSEMBLY

PHYSICAL CONFIGURATION OF DETECTOR/MAGNET ASSEMBLY

As shown in Figure 5-3A, the Detector/Magnet Assembly consists of three major components; the magnet assembly, the detector assembly and the optical bench assembly.

The magnet assembly includes a sample pre-heating coil. It is connected into the sample line upstream from the detector and is heated to approximately the same temperature as the detector assembly.

For convenience in servicing, the detector and the optical bench are self-aligning assemblies that utilize slip-on sample connections and plug-in electrical connections.

Within the detector assembly, Figure 5-3B, the incoming preheated sample passes through an integral 5 micron diffusion screen. It protects the test body by preventing entry of particulate matter and/or entrained liquid mist. Additionally, the screen isolates the test body from flow effects, ensuring that instrument readout is relatively independent of flow rate within the optimum range of 200 to 300 cc/min.

At the rear of the detector are an integral temperature sensor (RT1) and an integral heater (HR2). Another heater (HR1) is attached to the magnet. Sensor RT1 provides the input signal to the detector temperature control circuit of the Case Board assembly, Section 5.3.3. This circuit controls application of electrical power to both HR1 and Hr2.

On the optical bench assembly, Figure 5-3C, the source lamp and the photocell plate are externally accessible, permitting convenient replacement.

5.2 VARIABLES INFLUENCING PARAMAGNETIC OXYGEN MEASUREMENTS

Variables that influence paramagnetic oxygen measurements include: operating pressure, Section 5.2.1; sample temperature, Section 5.2.2; interfering sample components, Section 5.2.3; and vibration 5.2.4.

5.2.1 PRESSURE EFFECTS

Although normally calibrated for readout in percent oxygen, the Model 755A actually responds to oxygen partial pressure. The partial pressure of the oxygen component in a gas mixture is proportional to the total pressure of the mixture. Thus readout is affected by pressure variations. However, the instrument incorporates electronic circuitry that provides automatic pressure compensation for pressure variations within $\pm 3\%$ of the target value, which may be set anywhere in the range of -2.7 to 3.3 psig ± 3 psig (-18.6 to 22.8 kPa ± 21 kPa).



WARNING: POSSIBLE EXPLOSION HAZARD

Never subject the sensing unit to an absolute pressure of less than 500 mm Hg (66.7 kPa).

5.2.2 TEMPERATURE EFFECTS

Magnetic susceptibilities and partial pressures of gases vary with temperature. In the Model 755A, temperature-induced readout error is avoided by control of temperatures in the following areas:

1. Interior of the analyzer case is maintained at 140°F (60°C) by an electronically controlled heater and associated fan.
2. Immediately downstream from the inlet port, prior to entry into the detector, the sample is preheated by passing through a coil maintained at approximately the same temperature as the detector.
3. The detector is maintained at a controlled temperature of 150°F (66°C).

5.2.3 INTERFERENTS

Instrument response to most non-oxygen sample components is comparatively slight but is not, in all cases, negligible. Table 3-3 lists the readings that would be obtained with various gases on an instrument previously calibrated with 100% oxygen, assuming that all gases are admitted at the same pressure.

During initial installation of an instrument for a given application, effects of the background gas should be calculated to determine if correction is required. See Section 3.4.2.

5.2.4 VIBRATION EFFECTS

INSTRUMENT DESIGN

To minimize vibration effects, the detector/magnet assembly is contained in a shock-mounted compartment, Figure 1-2.

INSTALLATION

Avoid excessive vibration. In making electrical connections, do not allow any cable to touch the shock-mounted detector/magnet assembly or the associated internal sample inlet and outlet tubing. This precaution ensures against possible transmission of mechanical vibration through the cable to the detector, which would cause noisy readout.

ELECTRONIC RESPONSE TIME

If readout is noisy despite precautions mentioned above, obtain slower electronic response by counterclockwise adjustment of Response Time Adjust R30 (see Table 3-1, Figure 3-2).

5.3 ELECTRONIC CIRCUITRY

Electronic circuitry and internal interconnection wiring is shown in the schematic diagrams and wiring diagram in the rear of this manual. For detailed circuit analysis, refer to Section 6.

5.3.1 DETECTOR/MAGNET ASSEMBLY

A cross-sectional view of the optical bench and detector assemblies is shown in Figure 5-3B. Source lamp DS1, powered by a supply circuit on the Case Board

(Section 5.3.3), directs a light beam onto the mirror attached to the test body. The mirror reflects the beam onto dual photocell BT1, BT2.

The difference between the signals developed by the two halves of the photocell constitutes the error signal supplied to the input of amplifier U1 on the Control Board. Amplifier U1 drives U2 which, in turn, supplies the restoring current to the titanium wire loop on the test body (see Section 5.1).

ELEMENTS OF DETECTOR TEMPERATURE CONTROL CIRCUIT

Detector temperature is sensed by thermistor RT1, an integral part of the detector assembly (see Figure 5-3B). The thermistor provides the input signal to the detector temperature control circuit on the Case Board:

The output from this circuit is applied to the two heaters within the detector/magnet assembly; HR1, mounted on the top of the magnet, and HR2, mounted permanently on the rear of the detector assembly.

5.3.2 CONTROL BOARD AND ASSOCIATED CIRCUITRY

The Control Board contains signal conditioning and control circuitry. The Control Board is mounted on the inside of the analyzer door (see Figure 1-2).

The Control Board contains the following:

INPUT AMPLIFIER U1

This amplifier receives the error signal from the dual photocell of the detector assembly and drives amplifier U2.

AMPLIFIER U2 AND ASSOCIATED ZERO ADJUSTMENT

Amplifier U2 supplies the restoring current to the titanium wire loop of the test body within the detector assembly. Front panel ZERO Control R13 applies an adjustable zero biasing signal to the input of U2 to permit establishing a zero calibration point on the display or recorder. With downscale zero standard gas flowing through the analyzer, the ZERO control is adjusted for the appropriate reading.

AMPLIFIER U4 AND ASSOCIATED SPAN ADJUSTMENT

Amplifier U4 and associated feedback resistors provide a signal amplification of X4, resulting in a signal level suitable for analog divider circuit U6. Front panel SPAN adjustment R16 modifies the value of the input resistance and hence the signal amplification factor. Adjustment range is approximately $\pm 30\%$.

The SPAN adjustment permits establishing an upscale calibration point on the display

or recorder. With upscale standard gas flowing through the analyzer, the SPAN control is adjusted for the appropriate reading.

PRESSURE COMPENSATION CIRCUIT

The pressure compensation circuit consists of divider U6 and associated components. This circuit provides a pressure-corrected output signal conditioned to the range of 0 to 10 VDC. The circuit solves the follow equation:

$$V_o = k (V_x/V_z)$$

where

V_o = the corrected output signal

V_x = the amplified detector-output signal, which includes a pressure factor

V_z = the pressure signal derived from: (a) The pressure sensor and associated amplifiers, and (b) the positive reference voltage power supply

k = the constant that is characteristic of the circuit

AMPLIFIER U8

This amplifier works in conjunction with analog divider U6, providing conditioned output signal V_o as described in Pressure Compensation Circuit above.

AMPLIFIER U10

U10 is an non-inverting buffer amplifier that incorporates an anticipation arrangement in its input network, thus providing slightly faster response time (90% of fullscale on the readout device(s).

Potentiometer R30 provides a continuously variable adjustment of 5 to 25 seconds for the electronic anticipation time and is factory-set for 20 seconds.

Since the anticipation network attenuates the signal, a gain of 10 is provided in U10 to restore the signal to the desired fullscale range of 0 to 10 VDC.

The pressure-corrected signal from U10 is routed to two output circuit:

Digital Output Circuit. The signal from U10 passes through TEST switch SW1 and a filter circuit to an integrating analog-to-digital converter. The resulting digital signal drives the liquid crystal display.

Analog Output Circuit . The output from U10 is provided as an input to the recorder output amplifier. This circuitry provides zero suppression, scale expansion, and amplification preparatory to use for potentiometric recorder, voltage-to-current conversion for current recorder, and/or alarm functions.

Zero suppression is obtained as the sum of (1) a jumper selectable, fixed value of 0%, 20%, 40%, 60%, or 80% and (2) a continuously adjustable value of 0% to 25%.

The scale expansion factor is jumper selectable for 1, 10, or 100.

Potentiometric output is jumper selectable for 0 to 10mV, 0 to 100mV, 0 to 1V, or 0 to 5VDC.

5.3.3 CASE BOARD

The Case Board contains power supply and temperature control circuits. The board is mounted inside of the analyzer case (see Figure 1-2).

The various circuits operate on main power transformer T1. The two primary windings of T1 are configured (at the factory) for operation on either 120 VAC or 220 VAC.

The Case Board consists of the following:

SOURCE LAMP POWER SUPPLY

This circuit provides a regulated output of 2.30 VDC to operate incandescent source lamp DS1 within the optical bench assembly. One secondary of main power transformer T1 drives a fullwave rectifier consisting of CR7 and CR8. The output of DS1 is held constant by a voltage regulator circuit utilizing U7, Q4, and Q5.

±15V POWER SUPPLY

This circuit provides DC voltages required for various amplifiers and other circuits. Fullwave rectifier bridge CR5 provides both positive and negative outputs. Each is routed through an associated series-type integrated circuit voltage regulator, providing regulated outputs of +15V and -15V.

DETECTOR TEMPERATURE CONTROL

This circuit maintains the detector at a controlled temperature of 150°F (66°C). Temperature is sensed by RT1, a resistance element permanently attached to the detector assembly.

The signal from the sensors is applied to amplifier U6, which drives transistors Q2 and Q3, thus controlling application of DC power from fullwave rectifier bridge CR6 to the two heaters within the detector/magnet assembly; HR1, mounted on the top of the magnet, and HR2, mounted permanently on the rear of the detector assembly.

CASE TEMPERATURE CONTROL

This circuit maintains the interior of the analyzer case at a controlled temperature of 140°F (60°C). Temperature is sensed by a thermistor on the Control Board adjacent to critical electronic components. The circuit provides on-off control of heater element HR3 via TRIAC Q7. Heater HR3 is located in the heater/fan assembly.

5.3.4 ISOLATED CURRENT OUTPUT BOARD (OPTIONAL)

An isolated current output is obtainable by insertion of an optional plug-in circuit board into receptacle J1 on the Control Board assembly (See Figure 1-2). The current outputs available by this board are 0 to 20 mA or 4 to 20 mA.

5.3.5 ALARM OPTION

The alarm option provides two sets of relay contacts for actuation of (customer-supplied) alarm and/or process control device(s). The alarm relay assembly has two single-pole, double-throw relays, one each for the ALARM 1 and ALARM 2 contacts. Alarm output connections are on the terminal board shown in Figure 2-1.

ELECTRONIC CIRCUIT ANALYSIS

6

6.1 OVERVIEW

The electronic circuitry of the Model 755A Oxygen Analyzer consists of the following:

- A detector compartment heater circuit.
- A detector heater circuit.
- A $\pm 15\text{VDC}$ power supply.
- A voltage regulating circuit for a stable light source.
- A detector circuit with a first-stage amplifier to provide a feedback current for mechanical feedback to the detector and a scaling amplifier circuit to give an output change of 0 to +2.5V for a 0 to 100% change of the operating span.
- A digital output circuit for the digital read-out.
- An analog output circuit for recorder, optional alarms and current output.

6.2 $\pm 15\text{VDC}$ POWER SUPPLY

The components of the $\pm\text{VDC}$ power supply circuit are located in the lower left-hand corner of the Case Board. 19VAC should be measured with respect to ground at CR5 (WO4). +15VDC should be measured at the C27 (+) lead and -15VDC at the C28 (-) lead. If the specified voltage measurements are obtained, the power supply is working correctly.

6.3 CASE HEATER CONTROL CIRCUIT

The case heater control circuit utilizes four voltage-comparators (LM339 quad comparator). An understanding of how one of these comparators functions is necessary before any circuit analysis can be attempted.

In Figure 6-1, comparators 1 and 2 are depicted having a comparator within an overall comparator symbol. Also within this symbol, the base of the NPN transistor is connected to the output of the comparator. -15VDC is supplied to the emitter. The collector is illustrated as the overall output for the comparator package.

The use of a transistor, built into the output of the comparator, allows comparators to be placed together in an OR circuit. Comparators 1 and 2 (in Figure 6-1) illustrate this logic principle.

When the non-inverting terminal of comparator 2 is more positive than the inverting terminal, the transistor does not conduct and the collector of the transistor or comparator output is at whatever potential is then present on the collector.

When the non-inverting terminal of comparator 2 is less positive (more negative) than the inverting terminal, the transistor conducts and the output of the comparator is -15V. This value is the output of the OR circuit.

Comparator 2 is biased at 0 volts on the inverting terminal. Comparator 1 is biased at about 159 mV on the non-inverting terminal. Positive feedback or hysteresis is built into each comparator circuit for stability or positive action. This is achieved by the 20M ohm resistances, R70 and R73.

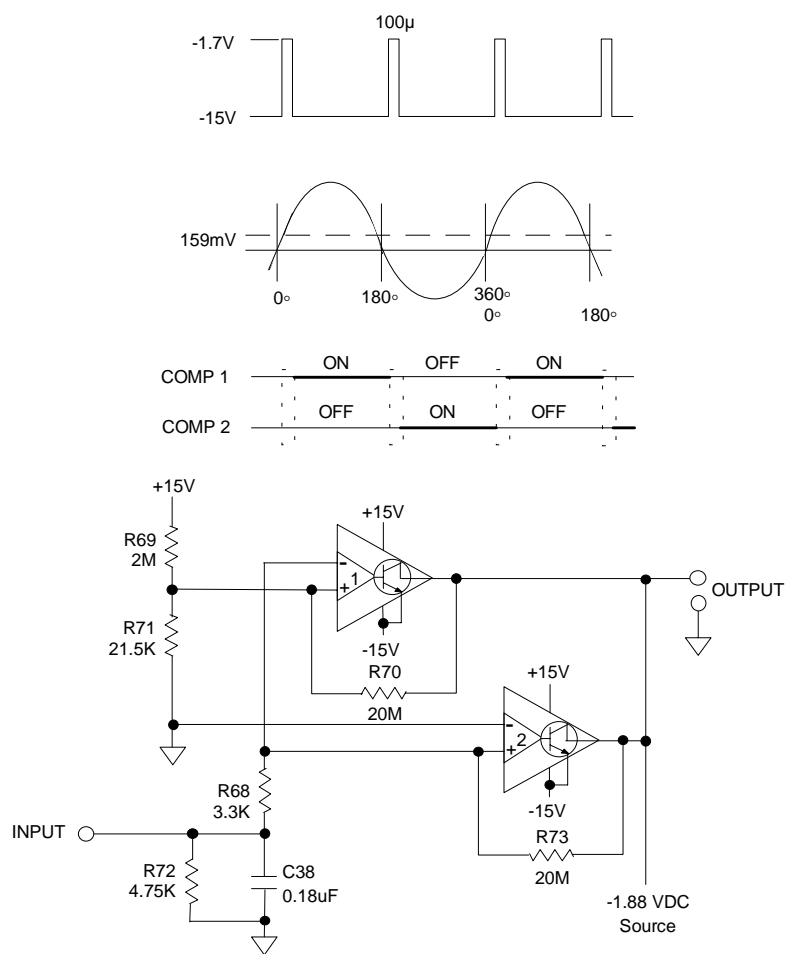

FIGURE 6-1. TWO-COMPARATOR OR CIRCUIT

An approximate 8V peak-to-peak AC signal is applied to comparators 1 and 2. As the signal starts going positive, comparator 2 transistor ceases conducting and comparator 1 transistor is off. When the signal exceeds the +159 mV on the non-inverting terminal, it turns on comparator 1 and the output is -15V.

Comparator 1 stays on until the signal drops below +159 mV, at which time the output will be the value of the OR bus. As the AC signal goes negative with respect to ground, the transistor of comparator 2 conducts and the output is again -15V. The output remains at -15VDC until the incoming signal crosses zero value and the positive signal causes the comparator 2 transistor to cease to conduct.

Summing the effects of the two comparators in the OR circuit results in no output from the comparators for about 4° of the sinewave, 2° after the signal goes positive (0 to 2°) and 2° before the positive signal reaches 180° (178° to 180°).

During the period that neither comparator is conducting, the value on the OR bus is the potential from the temperature-sensing bridge plus the effect of the ramp generator, probably $-1.88 \pm 0.03V$.

The on-off effect of the comparators to the OR circuit results in application of a positive-going pulse (from -15V to -1.89V) to the temperature bridge at the rate of 120 pulses per second.

Capacitor C36 is added to the input circuit to delay the incoming AC signal so that the pulses will occur at or just after the line frequency crossover point.

Circuits for a ramp generator (Figure 6-2) and a temperature-sensing bridge are part of the case heater control circuit (Figures 6-3 and 6-4).

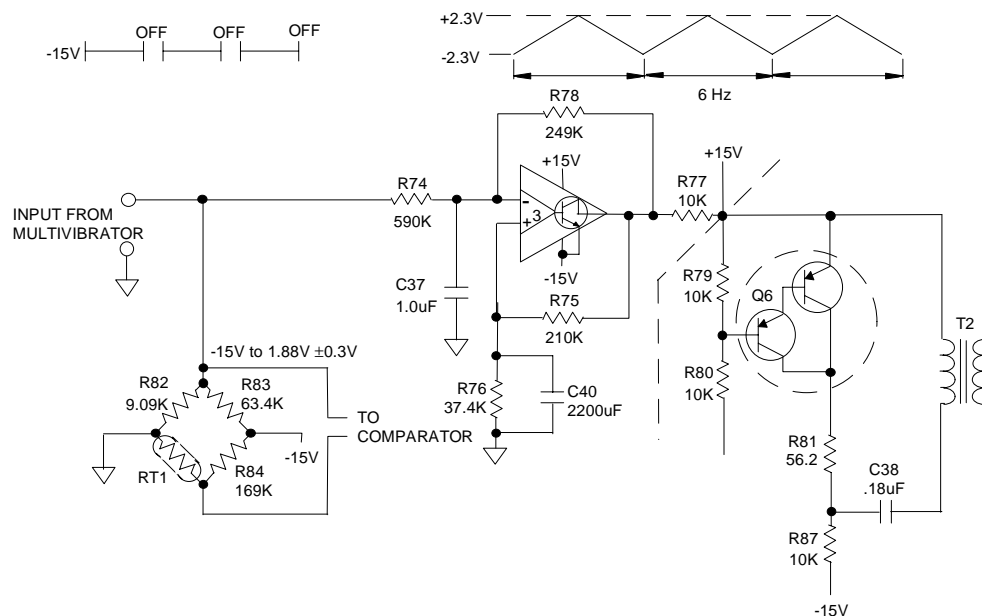

FIGURE 6-2. RAMP GENERATOR

Theoretically, at 135°F (57°C) the potential at the junction of RTR1 and R84 is -1.85VDC. This is equivalent to a resistance of 21.2 K. By substituting a decade box for the thermistor and placing 20.2 K into the bridge, the heater should be off. With 22.7 K, the heater should be full on.

Since the potential at the junction of R82 and R83 can vary between 1.85V and 1.92V according to the 6 Hz ramp, and the potential at the junction of RT1 and R84 may vary around or within these limits, depending on temperature, the error signal to comparator 4 may vary from 0 mV to some absolute value. The polarity of the error signal will depend on the deviation from the desired temperature and the ramp value at the function of R82 and R83.

The input from the OR circuit comparator (See Figure 6-1) is either -15VDC or the ramp effect on the bridge. When -15V, the junction of R82 and R83 is also this value. The error signal into comparator 4 is negatively large to the inverting terminal. Comparator 4 output transistor does not conduct. The base of Q6 is positive; therefore, Q6 does not conduct and a charge builds up on capacitor C38.

The input from the OR comparators 1 and 2, a form of multivibrator circuit, pulses 120 times a second. For about 100 microseconds the junction of R82 and R83 is some value between -1.85V and -1.92V, depending on the ramp generator. For this brief period of time (one pulse), comparator 4 compares the potential of junction R82, R83 with junction RT1, R84 of the bridge circuit. If the temperature at RT1 is low, the potential at the non-inverting terminal of comparator 4 is more negative and the output is -15V.

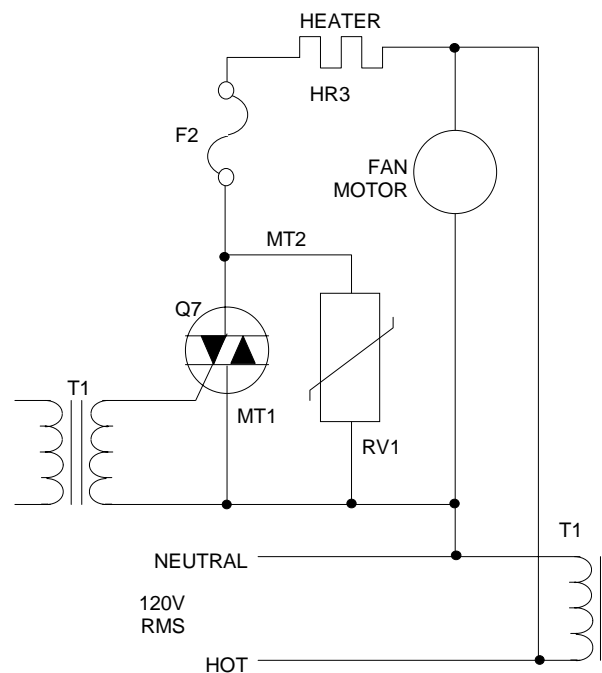

FIGURE 6-4. CASE HEATER CIRCUIT

The base of Q6 is zero, because of the voltage drops across R79 and R80; therefore, Q6 conducts. Energy, stored in C38, flows through Q6 as current and capacitor C38 discharges to zero potential. No current flows through the primary winding of transformer T2. At the end of the 100 microsecond pulse, the NPN transistor in the output of comparator 4 ceases to conduct, so the signal on the base of Q6 is +15V. Q6 ceases to conduct. C38 starts to charge, driving electrons (current) through the primary of T2. This induces a pulse into the secondary of T2 and to the gate of Triac Q7 (Figure 6-5) turning it on.

At the beginning of the next 100 microsecond pulse, comparator 4 output is again -15V, with zero volts on the base of Q6. Q6 again conducts, discharging C38. At the end of the 100 microsecond pulse, Q6 ceases to conduct. C38 charges and a pulse appears at the gate of Triac Q7, turning it on again. The charging time for C38 is about one-half a time constant (C38, R87) and ten time constants (R81, C38) are available for discharging C38.

The above action is repeated as long as the temperature is low, causing an error between R82, R83 junction and RT1, R84 junction. As the temperature approaches the desired case temperature of 135°F (57°C), differences between these two junctions will exist for only part of each ramp and the number of pulses operating Q7 will be proportional to the amount of error sensed by the 6 Hz ramp.

The pulses arrive at Q7 just as the supply AC line voltage is passing the zero-volt crossover point. The purpose of C36 (Figures 6-2, 6-4) is to delay the timing pulse, relative to line frequency, so that a pulse arrives at the gate of Triac Q7 as the line potential just passes the zero-volt crossover point (0° and 180° of line phase).

Varistor, RV1 is a temperature sensitive resistance device. When case temperature is low, such as ambient, the value of RV1 is low. Applying power at that temperature might cause a current surge to damage Triac Q7. RV1 with its low initial value of resistance acts as a bypass and most of the current is shunted through it.

As the temperature increases and approaches the desired case temperature, the resistance of RV1 increases to a large value. This limits the current through it and gives fine control of the heater to Triac Q7 and the temperature-sensing circuit.

6.4 DETECTOR HEATER CONTROL CIRCUIT

Figure 6-5 is a simplified heater control circuit drawing for the detector. Heaters 1 and 2 are actually connected in parallel and have a combined resistance of about 17 ohms.

The thermistor resistance (RT1) in the resistance bridge varies inversely with temperature. The bridge is designed to maintain the temperature of the detector at 150°F (65.5°C).

The junction point between R55 and R56 is maintained at a specific voltage since these resistances maintain a definite ratio. The thermistor resistance is 149 K at 150°F (65.5°C)

and increases rapidly as the temperature decreases. R59 in this bridge circuit represents the setpoint value for temperature. Suppose that, at temperature, resistance of the bridge (R55, R56, R59 and RT1) equals 149 K.

If the temperature goes down, RT1 increases in resistance and causes the junction of RT1 and R59 to go positive in voltage value. Since R55 and R56 are of equal resistance, their junction is at zero volts. Therefore, terminal 3 of AR6 is more positive than terminal 2 and the base of Q2 is positive. Q2 conducts, allowing alternating current to flow through heaters 1 and 2. The voltage drop across the heaters, when completely cold, would be about 20VAC and, when controlling, would be AC of very low amplitude.

As the temperature increases, the resistance of RT1 decreases and the junction point between RT1 and R59 becomes less positive. Terminal 3 of AR6 becomes less positive with respect to terminal 2. The output of AR causes Q2 and Q3 to conduct less. When terminal 3 equals terminal 2, or is less than terminal 2, the output of AR6 is zero or less. Q2 and Q3 do not conduct and the heater would not be supplying heat energy to the detector.

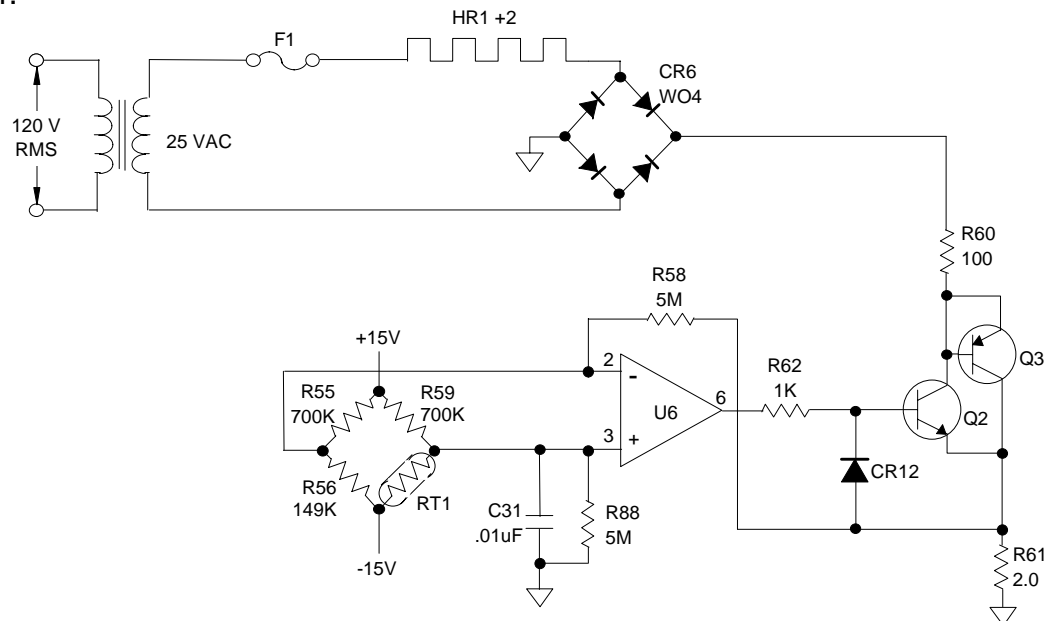

FIGURE 6-5. DETECTOR HEATER CONTROL CIRCUIT

6.5 DETECTOR LIGHT SOURCE CONTROL CIRCUIT

Refer to Figure 6-6. The detector light source control circuit maintains the light output from the bulb (DS1) as uniform as possible, regardless of voltage fluctuations or aging of the bulb.

The power source for the light bulb is a center-tapped secondary of transformer T1. This AC voltage is rectified by CR7 and CR8 and filtered (C32), presenting an approximate +8.5V bus to the current-limiting Darlington configuration of Q4. Q4 controls the basic amount of current through DS1.

Amplifier AR7 has a fixed value, approximately +2.2VDC on terminal 3. The output of AR7 is positive, causing Q4 to conduct. As Q4 conducts, electrons flow from the center-tap of T1 to ground and from ground through DS1 for an input voltage to terminal 2 of AR7, through R66 to develop a bias on the base of Q5, through Q4 to the +8.5V bus, and back to the secondary. As Q5 conducts, some of the current going through DS1 is shunted from the main current path, and goes through Q5, which acts as a variable feedback resistance, goes to the positive output potential of AR7.

As DS1 ages, its light emission decreases and its resistance increases. The current through DS1 tends to decrease, causing a decrease in the voltage drop across DS1 and the input potential to terminal 2 of AR7. Now the output AR7 will increase, causing Q4 to conduct more current through R66. As the potential across R66 increases, Q5 will conduct more current, causing a further increase in current flow through DS1. The net result is that the voltage across DS1 will remain uniform and the operation of Q4 and Q5 will adjust the gain of AR7 to maintain the light emission from DS1 uniform for a long period of time.

Voltage fluctuations in the 115VAC supply could cause some variation in the amount of current flowing through the bulb DS1. However, the voltage drop across DS1 would cause AR7 to adjust Q4 and the voltage drop across R66 to adjust Q5. The net result would still be uniform current flow through DS1 and uniform light emission.

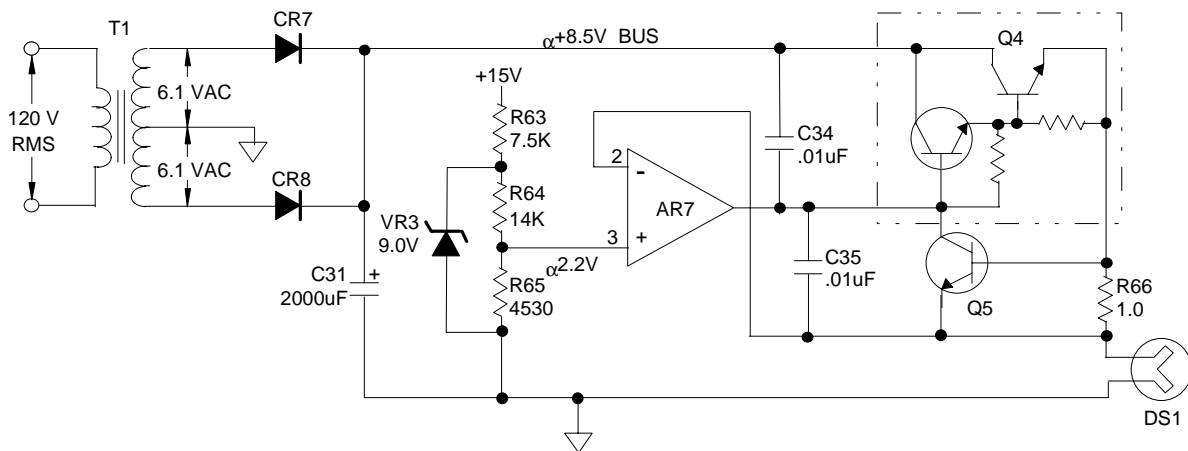

FIGURE 6-6. DETECTOR LIGHT SOURCE CONTROL CIRCUIT

6.6 DETECTOR WITH FIRST STAGE AMPLIFIER AND PRESSURE COMPENSATION CIRCUITS

Refer to Figure 6-7. The detector assembly consists of a test body suspended on a platinum wire and located in a non-uniform magnetic field.

The test body is constructed of two hollow glass spheres forming a dumbbell shape. They are filled and sealed with pure, dry nitrogen. Around the test body, a titanium wire is chemically etched in order to form a feedback loop that can create a

counteracting magnetic force to the test body displacement caused by oxygen concentration in the test assembly magnetic field.

Attached to the center arm of the test body dumbbell is a diamond-shaped mirror. Attached to the mirror are two separate platinum wires in tension with the supports for the test body. The supports are isolated from ground and are electrically connected to the feedback loop and the electronics for that loop. The platinum wires form a fulcrum around which the test body pivots.

The detector operates in the following fashion. If the sample gas contains oxygen, it collects in the non-uniform magnetic field around the test body. Oxygen, because of its paramagnetic qualities, gathers along the magnetic lines of flux and forces the dumbbell of the test body out of the magnetic field.

A light source is focused on the test body mirror. As the test body moves out of the magnetic field, the mirror distributes light unevenly on two photocells (BT1 and BT2). The photocells create a potential at comparator U1. The output of U1 goes to U2. The output of U2 causes current to flow through the feedback loop attached to the dumbbell and mirror into the test assembly magnetic field until the mirror reflects light almost uniformly on each photocell. A current proportional to the oxygen concentration in the magnetic field of the test assembly has to be flowing through the feedback loop in order to maintain balance and provide a reading of the oxygen content of the sample.

Resistances R5, R17 and the resistance of the wire in the feedback loop determine the gain of amplifier AR2. The mirror on the dumbbell is positioned by the amount of current in the feedback loop. The mirror reflects light from the source (DS1) to the photocells (BT1, BT2). This repositioning of the mirror is a form of mechanical feedback to the input of the amplifier U1. The net result is that the output of U1 could vary from 0 to -70 mV, or 0 to -7.0V, depending on the range of the instrument

On application of AC power, capacitor C6 has no charge. The current will have to flow through R18. Initially the full 30V drop (the difference between the ± 15 VDC power) will appear across R18. The cathode of CR2 will be initially at -15VDC. The anode of CR2 will be some value more positive than -15VDC. CR2 will conduct. The input terminal of U1 will be negative and the current through the feedback loop around U2 will cause the dumbbell and mirror to be positioned correctly in the test body.

As the charge on C6 increases, the cathode of CR2 becomes more positive. When it exceeds that on the anode, CR2 ceases to conduct and isolates the ± 15 VDC power supply from the input circuit.

Coarse Zero Adjust R9 and front panel ZERO potentiometer R13 permit adding an appropriate voltage to the input of U2 to counteract any electrical offset resulting from imbalance in the detector and/or photocells BT1 and BT2.

The output current that U2 must provide to restore the dumbbell is a measure of the

displacing force and thus is a function of both (a) the % oxygen concentration of the sample and (b) the sample pressure.

The output from U2 is further amplified by U4 to provide a 0 to 10VDC output that constitutes signal V_x for the pressure compensation circuit described in Section 6.61.

PRESSURE COMPENSATION CIRCUIT

This circuit provides a pressure-corrected output signal conditioned in the range of 0 to 10VDC. The circuit solves the following equation:

$$V_o = k (V_x/V_z)$$

where

V_o = the corrected output signal

V_x = the amplified detector-output signal, which includes a pressure factor

V_z = the pressure signal derived from: (a) The pressure sensor and associated amplifiers, and (b) the positive reference voltage power supply

k = the constant that is characteristic of the circuit

Circuit function is such that, assuming a constant % oxygen concentration in the sample stream, the output from the analog divider U6 (and thus also the conditioned output from amplifier U8) will remain constant regardless of pressure variations within the specified range.

PRESSURE SIGNAL CIRCUIT

Refer to Figure 6-8. The pressure signal circuit consists of the pressure sensor (transducer) and two associated amplifiers. The sensor provides a voltage output that is proportional to pressure. This signal is ratioed and combined with the negative voltage reference so as to provide a zero-based signal at the output of the first amplifier, where it is available for measurement and display for calibration and setup purposes.

The second amplifier adds the 10V reference back ;into the pressure signal. The output from the second amplifier is then appropriately attenuated to provide signal V_z for analog divider U6. Signal V_z is also made available to the display and measurement circuit, Section 6.9, for calibration purposes.

POSITIVE AND NEGATIVE REFERENCE VOLTAGE CIRCUITS

These circuits provide precisely controlled voltages that set overall system performance and accuracy for the oxygen measurement system. While the absolute accuracy is of importance, more important yet is the ability of these circuits to remain stable despite temperature variations that may occur during normal instrument usage.

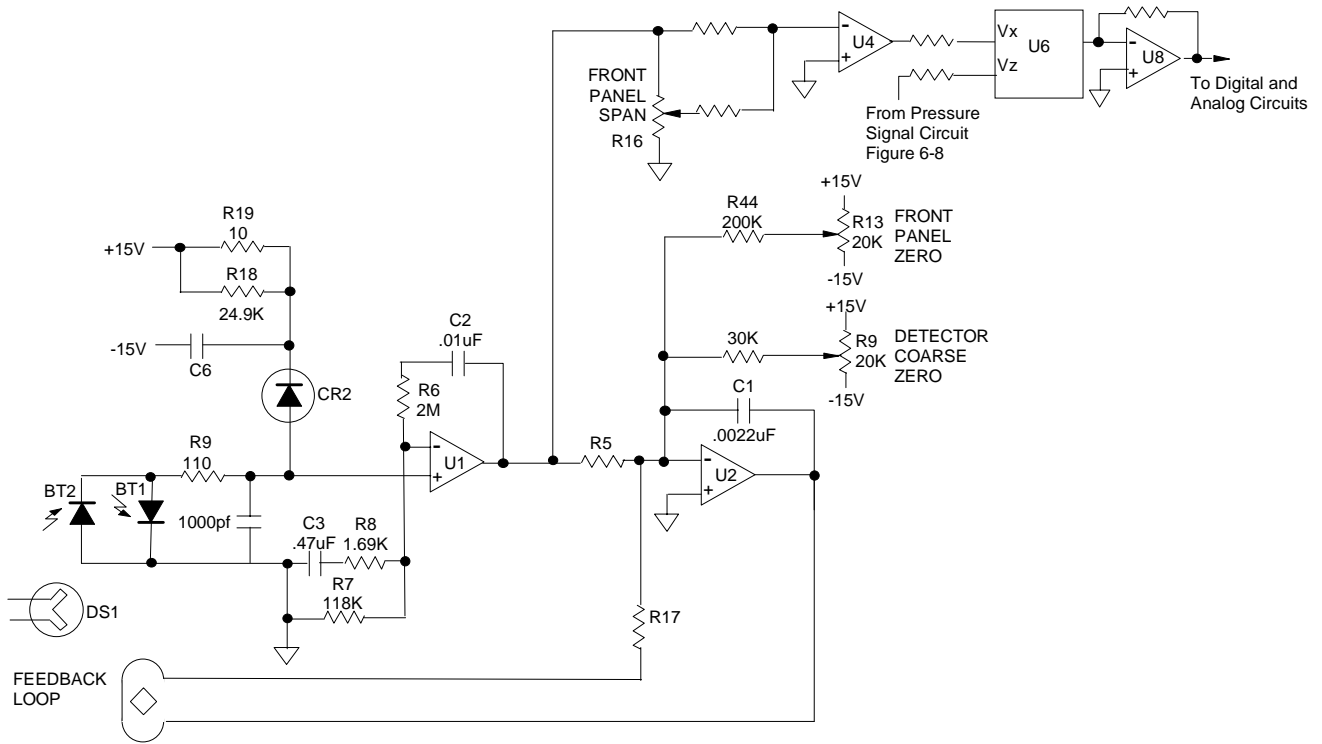

FIGURE 6-7. DETECTOR WITH FIRST STAGE AMPLIFIER AND PRESSURE COMPENSATION CIRCUITS

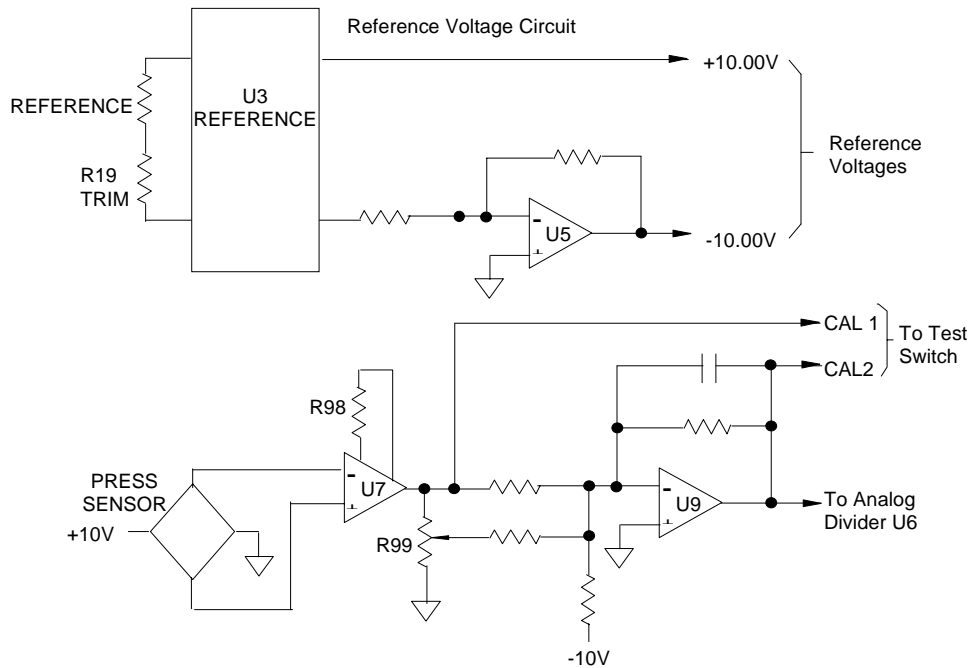

FIGURE 6-8. PRESSURE SIGNAL AND REFERENCE VOLTAGE CIRCUITS

6.7 BUFFER AMPLIFIERS U10 AND ASSOCIATED ANTICIPATION FUNCTION

Refer to Figure 6-9. U10 is a non-inverting buffer amplifier that incorporates an anticipation arrangement in its input network, thus providing slightly faster response on the readout device(s).

Potentiometer R30 provides a continuously variable adjustment of 5 to 25 seconds for the electronic response time (90% of fullscale) and is factory-set for 20 seconds.

Since the anticipation network attenuates the signal, a gain of 10 is provided by the feedback network associated with U10 to restore the signal to the desired fullscale range of 0 to 10VDC.

The pressure-corrected output signal from U10 is routed to two output circuits:

- Digital Output Circuit, Section 6.8
- Analog Output Circuits for Recorder and Alarms, Section 6.9

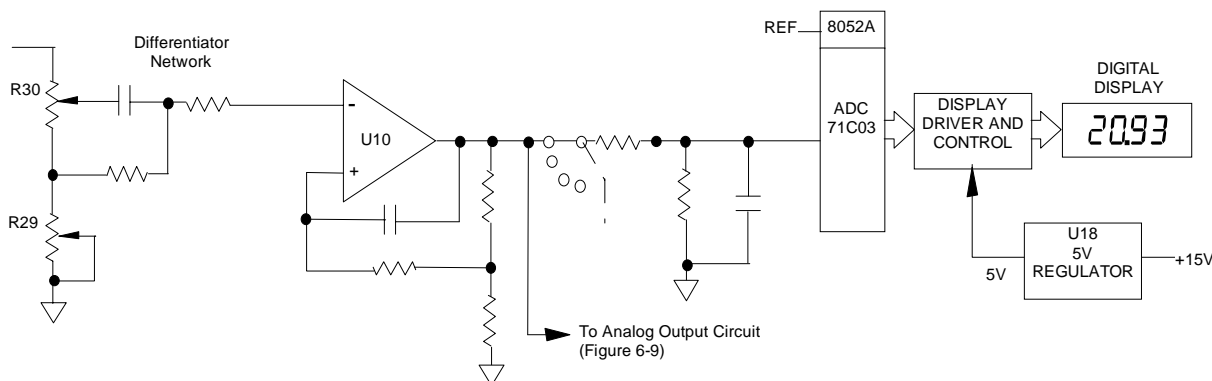

FIGURE 6-9. BUFFER, ANTICIPATION, AND DIGITAL OUTPUT CIRCUIT

6.8 DIGITAL OUTPUT CIRCUIT

Refer to Figure 6-10. With front panel TEST Switch in position 1, the output signal from buffer amplifier U10 is routed through an attenuator and filter network to an integrating analog-to-digital converter. It converts the signal into an equivalent digital value in the range of 0.00% to 99.99%. Any value above 99.99% will be preceded by an over-range bit, for example, 1.1123.

The output of the ADC consists of binary-coded decimal characters that are input to the liquid crystal controller and display chip characters sequentially in time. The BCD characters are converted into seven-line codes to drive the bar segments of the liquid crystal display.

A separate regulator circuit, which operates from the +15VDC supply, provides a regulated 5VDC for the digital functions associated with the display.

6.9 ANALOG OUTPUT CIRCUITS FOR RECORDER AND ALARMS

Refer to Figure 6-10. The analog output circuits utilize two amplifiers:

FIRST STAGE AMPLIFIER

This amplifier permits selecting the desired fullscale oxygen range for the recorder by an appropriate combination of scale expansion and zero suppression.

Scale expansion is accomplished by selecting the appropriate feedback resistor in a switch-selectable network, thus establishing one of six values for amplifier gain:

DESIRED OXYGEN SPAN FOR RECORDER	REQUIRED AMPLIFIER GAIN
100%	1X
20%	5X
10%	10X
5%	20X
2%	50X
1%	100X

The desired zero suppression is obtained as the sum of (a) a jumper-selectable fixed value of 0%, 20%, 40%, or 80% oxygen and (b) a continuously adjustable value of 0% to 25% oxygen. Thus the total zero suppression may be set for any desired valued from 0% to 105% oxygen.

In order to establish the precise zero suppression required for the recorder output, the actual applied zero suppression may be read on the digital display by placing the front panel TEST Switch in position 4 and the recorder scale-expansion jumper in the 100% (i.e., 1X gain) position.

Note that, in this mode the signal input is disconnected, allowing only the input offset current for the zero-suppression function to flow into the amplifier summing node.

Example 1, Selection of a Zero Based Recorder Oxygen Range:

Desired oxygen range for recorder output: 0% to 100%

Required span is 100% oxygen; thus a gain of 1 is selected with the jumper.

Required zero suppression is 0%; thus, the Zero Suppression Selection Jumper is removed, and the Zero Suppression Potentiometer is set for 0%.

Example 2, Selection of a Zero Suppression Recorder Oxygen Range:

Desired oxygen range for recorder output: 90% to 100%.

Required span is 10% oxygen; thus, a gain of 10 is selected with the jumper.

Required zero suppression is 90% oxygen; thus the Zero Suppression Selection Jumper is placed in the 80% position, and the Zero Suppression Potentiometer is set for 10% oxygen.

SECOND STAGE AMPLIFIER

This amplifier is an inverting configuration that provides a signal attenuation of 2X, thus reducing the 10-volt fullscale input signal to obtain a 5-volt fullscale output. This output is routed to:

Recorder Output Resistor Network. It provides a jumper-selectable output of 0 to 10 mV, 0 to 100 mV, 0 to 1V, or 0 to 5VDC for a potentiometric recorder.

Current Output Receptacle J1. This connector accepts the optional plug-in current-output board.

Dual Alarm Amplifier Circuit. This circuit drives the optional 638254 Alarm Relay Assembly.

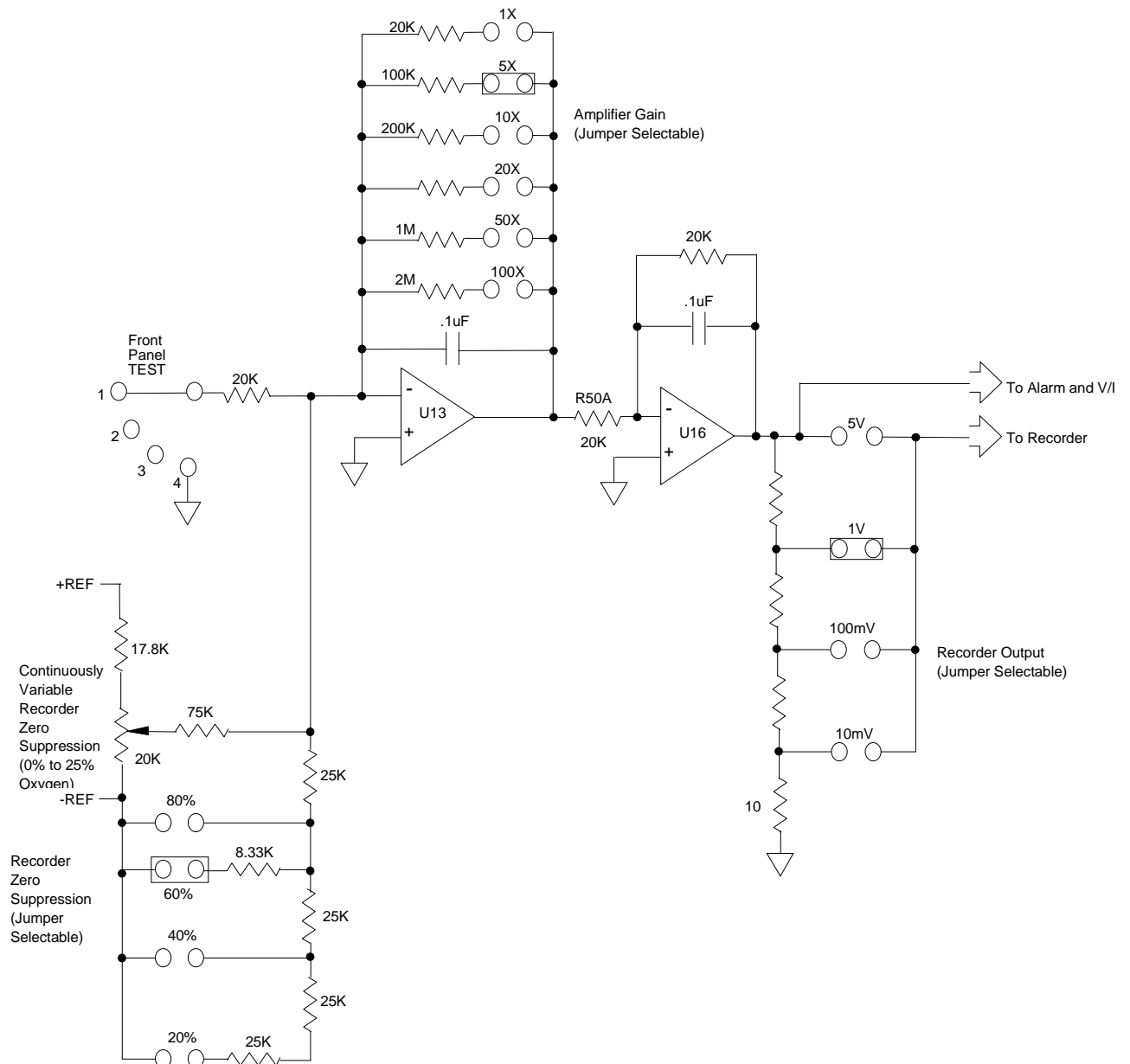

Resistor Values are in Ohms.

FIGURE 6-10. SIMPLIFIED ANALOG OUTPUT CIRCUIT FOR RECORDER (SHOWING THREE RANGES)

NOTES

7 ROUTINE SERVICE AND MAINTENANCE



WARNING: POSSIBLE EXPLOSION HAZARD

If gases are introduced into this analyzer, the sample containment system must be carefully leak-checked prior to initial start-up, during routine maintenance and any time the integrity of the sample containment system is broken, to ensure the system is in leak-proof condition. Leak-check instructions are provided in Section 2.3.8.



WARNING: ELECTRICAL SHOCK HAZARD

Do not operate without doors and covers secure. Servicing requires access to live parts which can cause death or serious injury. Refer servicing to qualified personnel.



CAUTION: PARTS INTEGRITY

Tampering or unauthorized substitution of components may adversely affect safety of this product. Use only factory documented components for repair.

The information provided in this section will aid in isolation of a malfunction to a particular assembly or circuit. No detailed procedures for component service and maintenance are provided, as they are beyond the scope of this manual. A few detailed checks are included, but only for location of the defective assembly. It is recommended that those familiar with circuit analysis refer to the circuit theory in Section 6 of this manual.

7.1 INITIAL CHECKOUT WITH STANDARD GASES

If instrument readings do not meet specifications, the first step in troubleshooting is to isolate the analyzer from the sample stream and the sample-handling system.

Admit downscale and upscale standard gases to the analyzer. Observe readout on digital display and on recorder (if used).

Digital display reads correctly with standard gases but not with sample gas, the sample and sample-handling systems are suspect. Check these areas.

Digital display reads correctly with standard gases, but the alarm or output devices do not, these devices must be checked individually.

Digital display reads overrange or erratic with standard gases as well as with sample gas, the problem is probably in the detector or the electronic circuitry.

- **Ovrerrange** - Turn power to analyzer OFF. Tap detector compartment with fingers. Wait 30 seconds, reapply power. If the suspension within the detector assembly is hung up, this procedure may correct the condition. If not, proceed with tests of the detector and electronics.
- **Erratic** - Problem probably in the detector or the temperature control circuits. Proceed with tests of the detector and electronics. Verification that all circuits are operating properly should be performed before replacing detector.

7.2 DETECTOR COMPONENT CHECKS

7.2.1 DETECTOR

Before concluding that the detector is defective and must be replaced, verify that all components and circuits that could cause erratic readings are operating properly.

To isolate the detector as a source of a problem, the source lamp, photocells and suspension should be checked for proper operation.

7.2.2 SOURCE LAMP

To verify that the source lamp is operating properly:

1. Verify that lamp is lit.
2. Voltage at U7 pin 2 should be 2.2 ± 0.2 VDC.

If lamp is not operating properly, replace per instructions in Section 7.3.2.

7.2.3 PHOTOCELL

To verify that photocell is operating properly, perform the following steps:

1. Keeping power source ON, disconnect the leads of the photocell from connector J12. See Figures 7-1, 7-2.
2. Note the current measurement between the gray and orange wires (between 300 to 450 mA).
3. Measure between the orange and red wires. The reading should be approximately the same as step 2.

If photocell readings not correct, replace photocell per Section 7.3.3.

7.2.4 SUSPENSION

If the suspension has been damaged, the cause may be improper operating conditions.

Maximum permissible operating pressure for the detector is 10 psig (69 kPa gauge pressure). To ensure against over-pressurization, a pressure relief valve may be inserted into the sample inlet line. In addition, a check valve should be inserted into the vent line, if connected to a manifold associated with a flare or other outlet that is not at atmospheric pressure. If the detector is over-pressurized, the suspension could break.

To verify correct operation:

1. Turn electrical power to analyzer OFF.
2. Remove optical bench assembly (see Section 7.3.2, steps 1 through 4.)
3. With 100% nitrogen flowing through the analyzer, note the position of the suspension.
4. Admit air and note response of suspension. It should rotate clockwise (as viewed from the top) and to the right (as viewed through the window).

Failure to rotate indicates that the suspension has been damaged and that the detector assembly must be replaced. See Section 7.3.1.

7.3 DETECTOR COMPONENT REPLACEMENT

7.3.1 DETECTOR REPLACEMENT

Prior to removal of the detector, remove power from instrument and stop flow of sample gas.

1. Remove the four screws securing the detector cover plate.
2. Disconnect cable from J12 on the detector assembly.

Note

Note how the rubber sample lines are looped into a "long coil". When reinstalling the sample lines they must be configured in the same way. This precaution isolates the detector from the effects of mechanical vibration. Otherwise vibration waves could travel upward along the tubing walls, resulting in noisy readout.

3. Refer to Figure 7-1. Using needle-nose pliers, squeeze the hose clamps to disconnect the rubber sample lines from the metal inlet and outlet tubes of the detector assembly.
4. Remove the two screws at the bottom of the detector assembly, slide detector out.
5. Install replacement detector assembly and connect cable to J12.

6. Seat the detector assembly firmly against the magnet pole pieces and tighten attaching screws.
7. Reconnect rubber sample lines to metal inlet and outlet tubes on detector assembly.
8. Apply power to instrument and allow to warm up approximately one hour.
9. Set the front panel ZERO control (R13) at mid-range (i.e., five turns from either end).

A. Detector/Magnet Assembly - Exploded View

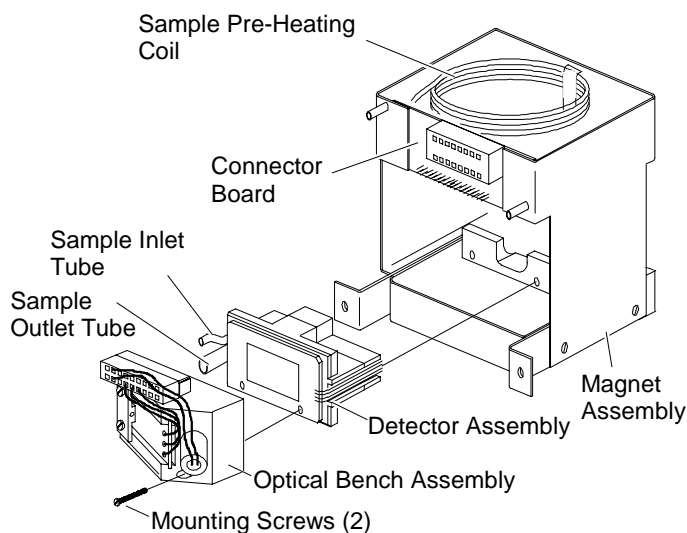

B. Optical Bench - Exploded View

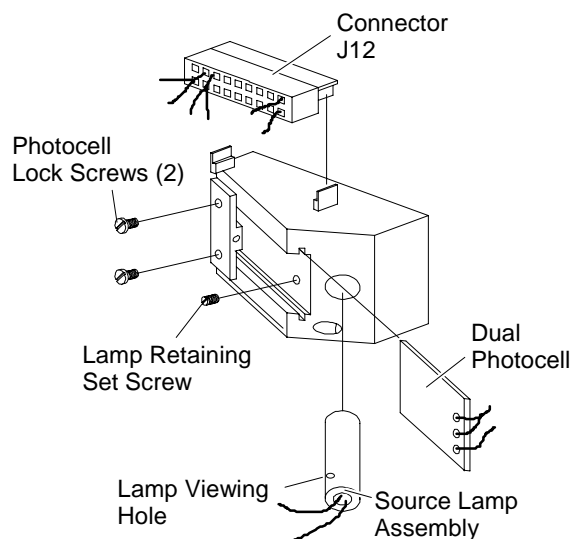
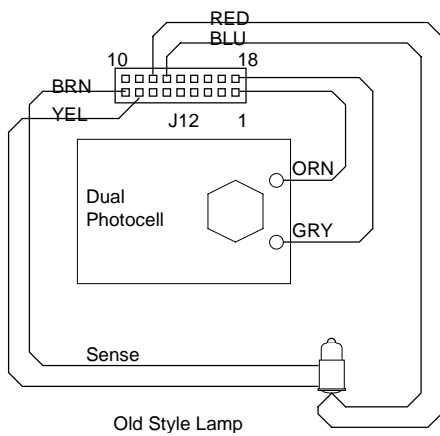

FIGURE 7-1. DETECTOR/MAGNET ASSEMBLY

10. Refer to Table 3-1, Figure 3-2 and Figure 7-3. Connect a digital voltmeter (four digit resolution) from the slider of Coarse Zero potentiometer (R9) to chassis ground. With a steady flow of 50 to 500 cc/min. of nitrogen gas passing through the instrument, adjust Coarse Zero (R9) for zero volts.
11. Connect the voltmeter between TP10 and circuit ground. Adjust front panel ZERO control (R13) for reading of exactly zero on voltmeter.

With all internal adjustments now properly set, the instrument may be calibrated in the normal manner.

A. Connections to Source Lamp and Photocell



B. Connections to Suspension and Heater Circuits

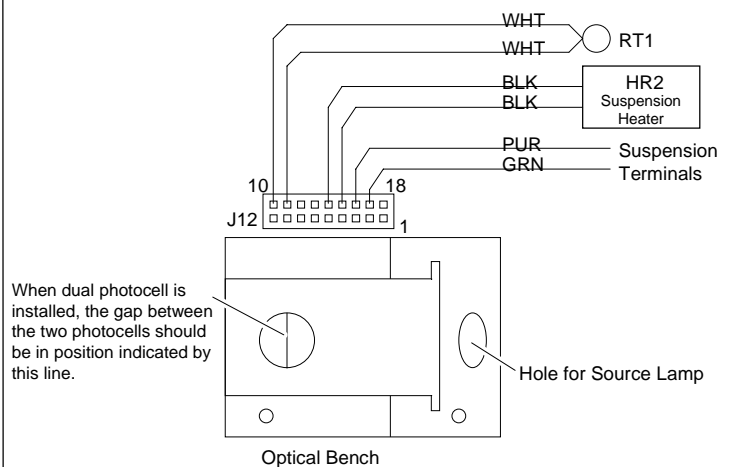

C. Removal and Insertion of Pin/Leads in Connector J12

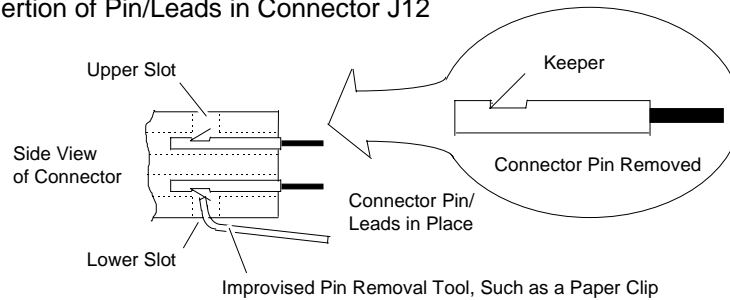

FIGURE 7-2. DETECTOR/MAGNET ASSEMBLY WIRING

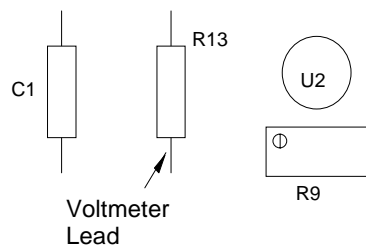

FIGURE 7-3. DETECTOR ADJUSTMENT

7.3.2 SOURCE LAMP REPLACEMENT

1. Remove the four screws securing the detector assembly cover plate.
2. Refer to Figure 7-1. Carefully remove the small rubber hose connected from the detector/magnet assembly to the detector.
3. If retaining set screw for lamp is accessible, proceed to step 6. If the set screw is not accessible continue to step 4.
4. Remove the two screws holding the optical bench assembly/detector assembly to

the magnet assembly. Carefully remove optical bench and detector assembly.

5. Remove the two lock screws (2-56 X 5/16 pan head) holding the photocell in the optical bench. Carefully remove photocell.
6. Loosen lamp retaining set screw, remove lamp.
7. Note location of lamp wires in connector J12. Disconnect leads of lamp assembly from connector J12, Figure 7-2A, using method shown in Figure 7-2C.

Depending on date of manufacture of the analyzer, the original lamp assembly may be either of two types:

- a. Old style lamp assembly with four color coded leads: Red, blue, brown and yellow.

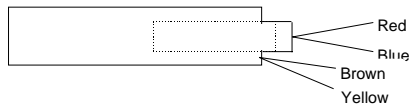

- a. New style lamp assembly with two leads color coded either both red or both black.

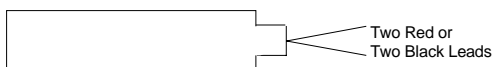

8. The replacement lamp assembly is the new style with two leads. On J12, insert one lead into the position formerly used for the brown lead to the old style lamp and the other lead into the position for the blue lead of the old lamp. See Figure 7-2A.
9. Insert the lamp into the assembly. After reassembly and application of power, the lamp will have to be rotated to place the lamp filaments in proper orientation.

If the lamp assembly removed from the instrument has *two* wires, proceed to step 13.

If the lamp assembly removed from the instrument has *four* wires, the 633689 Connector Board requires modification. Continue to step 10.

10. Refer to Figure 7-1. Remove the two screws holding the Connector Board to the magnet assembly. Carefully remove Connector Board.
11. Place Connector Board on a clean working surface, with solder side (no components) up.
12. Per Figure 7-4, add straps or solder bridges at the two points shown.

Note

If the Connector Board cannot be satisfactorily modified, a modified 633689 Connector Board may be ordered from the factory. See Section 8.

13. Reassemble detector, etc., in reverse order of disassembly.
14. Refer to Figure 7-5. The red line on the lamp must be aligned with the retaining set screw. Insert lamp into mounting hole until it extends 1/4 inch. Tighten set screw.

15. Realign the photocell per Section 7.3.3.

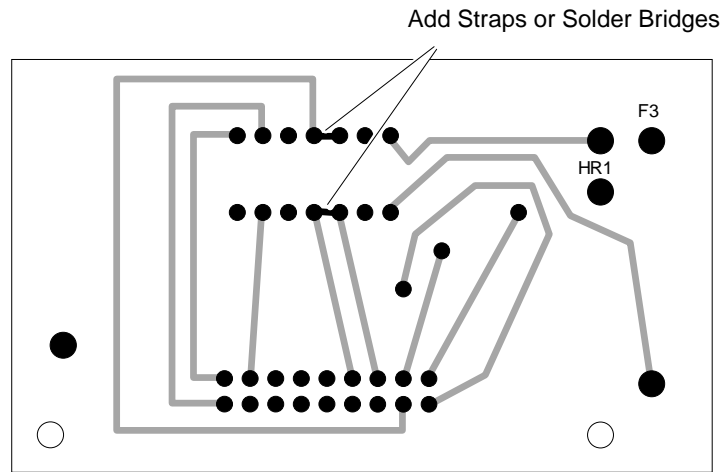

Solder Side of Board (Backside)

FIGURE 7-4. MODIFICATION OF 633689 CONNECTOR BOARD FOR COMPATIBILITY WITH REPLACEMENT LAMP

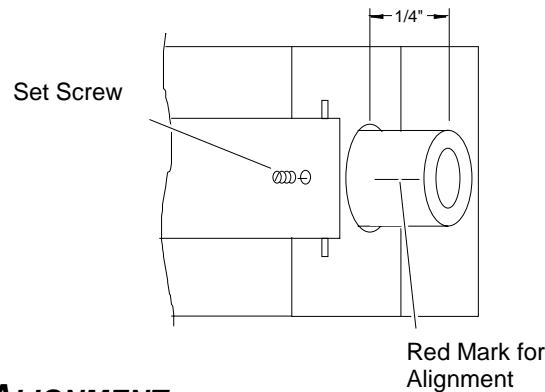

FIGURE 7-5. LAMP ALIGNMENT

7.3.3 PHOTOCELL REPLACEMENT AND ADJUSTMENT

1. To remove the photocell from the optical bench, perform steps 1 through 5 in Section 7.3.2.
2. Install replacement photocell by reversing removal procedure.
3. The photocell must now be adjusted. With zero gas flowing:
 - a. Place a digital voltmeter on the wiper of the front panel ZERO control (R13) and ground (TP7) ground on the Control Board. Adjust front panel ZERO control for 0.0 VDC.
 - b. Place the voltmeter from the bottom of R10 and TP7 (see Figure 7-5), adjust

R9 for 0 VDC.

- c. Place the voltmeter on TP8 and TP7, move the photocell to obtain a DC voltage as close to 0mV as possible but not more than $\pm 750\text{mV}$.

4. Perform steps 8 through 11 in Section 7.3.1.

With all internal adjustments now properly set, the instrument may be calibrated in the normal manner.

7.4 HEATING CIRCUITS

To ensure against damage from overheating in the event of malfunction, the heating circuits are protected by thermal fuses F2 and F3. If temperature of a heated area exceeds the permissible maximum, the associated fuse melts, opening the circuit.

Note

Thermal fuses F2 and F3 are to be plugged in, never soldered. If soldered, the fuse element may melt and open the circuit.

7.4.1 CASE HEATER CONTROL CIRCUIT

The case heater control circuit receives power via thermal fuse F2 (76°C). This fuse, located on the Case Board, can be checked for continuity.

Case heater element HR3, located on the heater/fan assembly, has a normal resistance of 20 ohms.

To verify heater operation, place a hand beside the right-hand side of the detector housing. Heated air should be felt. If it is not, check the case heating circuit.

Temperature sensor RT1 has a cold resistance of 22.7K ohms and a normal operating resistance of 20.2K ohms, indicating normal operating temperature of 140°F (60°C). Until thyristor RV1 reaches operating temperature, it bypasses most of the current that would otherwise flow through Triac Q7.

As a further check, disconnect connector plug P8 on the Control Board, thus disconnecting temperature sensor RT1. Substitute a decade resistor box to simulate the resistance of RT1. Also, connect an AC voltmeter from the hot side of the line to the neutral side of F2.

Set the decade box for 20.2K ohms to simulate RT1 resistance at controlling temperature. The voltmeter should now show pulses of 1 VAC.

**CAUTION: OVERHEATING HAZARD**

Avoid prolonged operation with the decade box set at 22.2K ohms. Overheating may result.

Set the decade box for 22.2K ohms to simulate RT1 resistance at ambient temperature. The voltmeter should now show pulses of 120 VAC.

7.4.2 DETECTOR/MAGNET HEATING CIRCUIT

Heater HR1 is attached to the magnet. Heater HR2 is attached to the rear of the detector. Combined resistance of these two parallel connected heaters, as measured at pins 15 and 16 of detector connector J12, should be approximately 17 ohms. If not, remove pin/leads 14 and 15 from the connector to measure the resistance of HR2 alone. This resistance should be approximately 89 ohms.

If resistance the resistance of HR2 is correct, and yet the combined resistance is incorrect, heater HR1 may be open.

To reach the leads of HR1, remove the printed circuit board on the heater assembly. Resistance of HR1 should be approximately 21 ohms.

To check operation of the heater circuit, connect a voltmeter across R61 on the Case Board. Normally, the voltage will be 4 VDC when cold and will drop to approximately 0.4 VDC at control temperature. Temperature sensor RT1 is mounted in the detector, with leads accessible at pins 10 and 11 of detector connector J12. The sensor resistance, as measured at these pins, should be 1M ohm at 25°C and approximately 149K ohms at operating temperature of 65°C.

NOTES

8 REPLACEMENT PARTS

The following parts are recommended for routine maintenance and troubleshooting of the Model 755A Oxygen Analyzer. If the troubleshooting procedures in Section 5 do not resolve the problem, contact your local Rosemount Analytical service office. A list of Rosemount Analytical Service Centers is located in the back of this manual.



CAUTION: PARTS INTEGRITY

Tampering or unauthorized substitution of components may adversely affect safety of this product. Use only factory documented components for repair.

8.1 CIRCUIT BOARD REPLACEMENT POLICY

In most situations involving a malfunction of a circuit board, it is more practical to replace the board than to attempt isolation and replacement of the individual component. The cost of test and replacement will exceed the cost of a rebuilt assembly. As standard policy, rebuilt boards are available on an exchange basis.

Because of the exchange policy covering circuit boards, the following list does not include individual, circuit board mounted components. If circumstances necessitate replacement of an individual component, which can be identified by inspection or from the schematic diagrams, obtain the replacement component from a local source of supply.

8.2 SELECTED REPLACEMENT PARTS

809374	Fuse, Power Transformer 3/4A (120VAC)
092114	Fuse, Power Transformer 1/2A (240VAC)
777362	Fuse, Heater 3A (120VAC) Pkg of 15
777361	Fuse, Heater 1.5A (240VAC) Pkg of 15
861469	Thermal Fuse (F2,F3)
656189	Detector/Optical Bench Assembly (0 to 1%)
656190	Detector/Optical Bench Assembly (Corrosion Resistant (0 to 1%)
616418	Source Lamp Kit
622350	Photocell

REPLACEMENT PARTS

652225	Transducer Assembly
621023	Current Output Board (0 to 20mA, 4 to 20mA)
631773	Case Board
652220	Control Board

GENERAL PRECAUTIONS FOR HANDLING AND STORING HIGH PRESSURE GAS CYLINDERS

*Edited from selected paragraphs of the Compressed
Gas Association's "Handbook of Compressed Gases"
published in 1981*

*Compressed Gas Association
1235 Jefferson Davis Highway
Arlington, Virginia 22202
Used by Permission*

1. Never drop cylinders or permit them to strike each other violently.
2. Cylinders may be stored in the open, but in such cases, should be protected against extremes of weather and, to prevent rusting, from the dampness of the ground. Cylinders should be stored in the shade when located in areas where extreme temperatures are prevalent.
3. The valve protection cap should be left on each cylinder until it has been secured against a wall or bench, or placed in a cylinder stand, and is ready to be used.
4. Avoid dragging, rolling, or sliding cylinders, even for a short distance; they should be moved by using a suitable hand-truck.
5. Never tamper with safety devices in valves or cylinders.
6. Do not store full and empty cylinders together. Serious suckback can occur when an empty cylinder is attached to a pressurized system.
7. No part of cylinder should be subjected to a temperature higher than 125°F (52°C). A flame should never be permitted to come in contact with any part of a compressed gas cylinder.
8. Do not place cylinders where they may become part of an electric circuit. When electric arc welding, precautions must be taken to prevent striking an arc against the cylinder.

(blank)

WARRANTY

Goods and part(s) (excluding consumables) manufactured by Seller are warranted to be free from defects in workmanship and material under normal use and service for a period of twelve (12) months from the date of shipment by Seller. Consumables, glass electrodes, membranes, liquid junctions, electrolyte, o-rings, etc., are warranted to be free from defects in workmanship and material under normal use and service for a period of ninety (90) days from date of shipment by Seller. Goods, part(s) and consumables proven by Seller to be defective in workmanship and/or material shall be replaced or repaired, free of charge, F.O.B. Seller's factory provided that the goods, part(s) or consumables are returned to Seller's designated factory, transportation charges prepaid, within the twelve (12) month period of warranty in the case of goods and part(s), and in the case of consumables, within the ninety (90) day period of warranty. This warranty shall be in effect for replacement or repaired goods, part(s) and the remaining portion of the ninety (90) day warranty in the case of consumables. A defect in goods, part(s) and consumables of the commercial unit shall not operate to condemn such commercial unit when such goods, part(s) and consumables are capable of being renewed, repaired or replaced.

The Seller shall not be liable to the Buyer, or to any other person, for the loss or damage directly or indirectly, arising from the use of the equipment or goods, from breach of any warranty, or from any other cause. All other warranties, expressed or implied are hereby excluded.

IN CONSIDERATION OF THE HEREIN STATED PURCHASE PRICE OF THE GOODS, SELLER GRANTS ONLY THE ABOVE STATED EXPRESS WARRANTY. NO OTHER WARRANTIES ARE GRANTED INCLUDING, BUT NOT LIMITED TO, EXPRESS AND IMPLIED WARRANTIES OR MERCHANTABILITY AND FITNESS FOR A PARTICULAR PURPOSE.

Limitations of Remedy. SELLER SHALL NOT BE LIABLE FOR DAMAGES CAUSED BY DELAY IN PERFORMANCE. THE SOLE AND EXCLUSIVE REMEDY FOR BREACH OF WARRANTY SHALL BE LIMITED TO REPAIR OR REPLACEMENT UNDER THE STANDARD WARRANTY CLAUSE. IN NO CASE, REGARDLESS OF THE FORM OF THE CAUSE OF ACTION, SHALL SELLER'S LIABILITY EXCEED THE PRICE TO BUYER OF THE SPECIFIC GOODS MANUFACTURED BY SELLER GIVING RISE TO THE CAUSE OF ACTION. BUYER AGREES THAT IN NO EVENT SHALL SELLER'S LIABILITY EXTEND TO INCLUDE INCIDENTAL OR CONSEQUENTIAL DAMAGES. CONSEQUENTIAL DAMAGES SHALL INCLUDE, BUT ARE NOT LIMITED TO, LOSS OF ANTICIPATED PROFITS, LOSS OF USE, LOSS OF REVENUE, COST OF CAPITAL AND DAMAGE OR LOSS OF OTHER PROPERTY OR EQUIPMENT. IN NO EVENT SHALL SELLER BE OBLIGATED TO INDEMNIFY BUYER IN ANY MANNER NOR SHALL SELLER BE LIABLE FOR PROPERTY DAMAGE AND/OR THIRD PARTY CLAIMS COVERED BY UMBRELLA INSURANCE AND/OR INDEMNITY COVERAGE PROVIDED TO BUYER, ITS ASSIGNS, AND EACH SUCCESSOR INTEREST TO THE GOODS PROVIDED HEREUNDER.

Force Majeure. Seller shall not be liable for failure to perform due to labor strikes or acts beyond Seller's direct control.

Rosemount Analytical

Rosemount Analytical Inc.

4125 EAST LA PALMA AVENUE • ANAHEIM, CALIFORNIA 92807-1802 • 714-986-7600 • FAX 714-577-8006
FEBRUARY 1997 • 7485189-C • PRINTED IN USA

(blank)

FIELD SERVICE AND REPAIR FACILITIES

Field service and repair facilities are located worldwide.

U.S.A.

To obtain field service on-site or assistance with a service problem, contact (24 hours, 7 days a week):

**National Response Center
1-800-654-7768**

INTERNATIONAL

Contact your local Rosemount Sales and Service office for service support.

FACTORY

For order administration, replacement Parts, application assistance, on-site or factory repair, service or maintenance contract information, contact:

**Rosemount Analytical Inc.
Process Analytical Division
Customer Service Center
1-800-433-6076**

RETURNING PARTS TO THE FACTORY

Before returning parts, contact the Customer Service Center and request a Returned Materials Authorization (RMA) number. Please have the following information when you call: *Model Number, Serial Number, and Purchase Order Number or Sales Order Number.*

Prior authorization by the factory must be obtained before returned materials will be accepted. Unauthorized returns will be returned to the sender, freight collect.

When returning any product or component that has been exposed to a toxic, corrosive or other hazardous material or used in such a hazardous environment, the user must attach an appropriate Material Safety Data Sheet (M.S.D.S.) or a written certification that the material has been decontaminated, disinfected and/or detoxified.

Return to:

**Rosemount Analytical Inc.
4125 East La Palma Avenue
Anaheim, California 92807-1802**

(blank)