Rosemount Analytical

ROX GT

ROX GP

OXYGEN ANALYZERS

INSTRUCTION MANUAL

748375-B

NOTICE

The information contained in this document is subject to change without notice.

Swagelok® is a registered trademark of Crawford Fitting Co.

Manual Part Number 748375-B
July 1998
Printed in U.S.A.

Rosemount Analytical Inc.
4125 East La Palma Avenue
Anaheim, California 92807-1802

CONTENTS

PREFACE

PURPOSE/SAFETY SUMMARY	P-1
SPECIFICATIONS - ROX GT TRACE OXYGEN ANALYZER.....	P-3
SPECIFICATIONS - ROX GP PERCENT OXYGEN ANALYZER	P-4
CUSTOMER SERVICE, TECHNICAL ASSISTANCE AND FIELD SERVICE	P-5
RETURNING PARTS TO THE FACTORY	P-5
TRAINING	P-5
DOCUMENTATION	P-5
COMPLIANCES	P-6

SECTION 1. INTRODUCTION

1.1 OVERVIEW	1-1
1.2 TYPICAL APPLICATIONS	1-1
1.3 THEORY OF TECHNOLOGY.....	1-2

SECTION 2. INSTALLATION

2.1 UNPACKING	2-1
2.2 ASSEMBLY	2-1
2.3 LOCATION	2-2
2.4 GASES	2-2
2.4.1 Connections.....	2-2
2.4.2 Gas Specifications	2-3
2.5 ELECTRICAL CONNECTIONS.....	2-5
2.5.1 Line Power Connection.....	2-5
2.5.2 Interconnections	2-5
2.5.3 Signal Output Connections	2-6
2.5.4 Alarm Connections.....	2-6
2.6 INSTALLATION GUIDELINES	2-6

SECTION 3. STARTUP AND OPERATION

3.1	STARTUP	3-1
3.2	CALIBRATION	3-1
3.3	OPERATION.....	3-2
3.4	ALARM SETPOINTS	3-2

SECTION 4. MAINTENANCE AND TROUBLESHOOTING

4.1	MAINTENANCE OVERVIEW	4-1
4.2	OXYGEN SENSOR REPLACEMENT.....	4-1
4.3	POWER FUSE REPLACEMENT	4-4
4.4	PRINTED CIRCUIT BOARDS.....	4-4
4.5	ALARM CONFIGURATION.....	4-4
4-6	TROUBLESHOOTING.....	4-6

SECTION 5. REPLACEMENT PARTS

5.1	ROX REPLACEMENT PARTS	5-1
5.1.1	Replacement Sensors	5-1
5.1.2	Replacement Parts List	5-1

APPENDIX A. MATERIAL SAFETY DATA SHEETS

- MATERIAL SAFETY DATA SHEET (PN 748378)
- MATERIAL SAFETY DATA SHEET (PN 748380)
- MATERIAL SAFETY DATA SHEET (PN 748381)

GENERAL PRECAUTIONS FOR HANDLING AND STORING HIGH PRESSURE GAS CYLINDERS

WARRANTY

FIELD SERVICE AND REPAIR FACILITIES

FIGURES

1-1 Electrochemical Sensor Technology 1-2
 1-2 ROX GT Front View..... 1-3
 1-3 ROX GP Front View 1-3
 2-1 ROX Top View (cover removed)..... 2-1
 2-2 Back Panel Connections 2-3
 2-3 Recommended Sample Handling Diagram - Positive Pressure Sample ... 2-4
 2-4 Recommended Sample Handling Diagram - Insufficient Pressure
 or Flow 2-4
 4-1 Sensor Installation..... 4-3
 4-2 Power Entry Module 4-4
 4-3 Alarm Switch Location 4-5

TABLES

4-1 Alarm Setting Configuration..... 4-6
 A-1 Sensor Reference Guide A-1

NOTES

PREFACE

PURPOSE/SAFETY SUMMARY

The purpose of this manual is to provide the procedures for the installation, operation and maintenance of the ROX GT trace oxygen analyzer and ROX GP percent oxygen analyzer..

Some sections may describe equipment not used in your configuration. The user should become thoroughly familiar with the operation of this analyzer before operating it. ***READ THIS INSTRUCTION MANUAL COMPLETELY.***

To avoid explosion, loss of life, personal injury and damage to this equipment and on-site property, all personnel authorized to install, operate and service this equipment should be thoroughly familiar with and strictly follow the instructions in this manual. SAVE THESE INSTRUCTIONS.

If this equipment is used in a manner not specified in these instructions, protective systems may be impaired.

DANGER is used to indicate the presence of a hazard which **will** cause **severe** personal injury, death, or substantial property damage if the warning is ignored

WARNING is used to indicate the presence of a hazard which **can** cause **severe** personal injury, death, or substantial property damage if the warning is ignored.

CAUTION is used to indicate the presence of a hazard which **will** or **can** cause **minor** personal injury or property damage if the warning is ignored.

NOTE is used to indicate installation, operation, or maintenance information which is important but not hazard-related.



WARNING: ELECTRICAL SHOCK HAZARD

Do not operate without doors and covers secure. Servicing requires access to live parts which can cause death or serious injury. Refer servicing to qualified personnel.

For safety and proper performance this instrument must be connected to a properly grounded three-wire source of power.



WARNING: ELECTRICAL SHOCK HAZARD

The output connection is for use only with equipment which has no live parts which are accessible.

The connecting cable and the equipment to which the output is connected must have insulation rated for at least 150 VAC, since under fault condition the output may be connected to the relay contacts which themselves may be connected to 150 VAC.

The connection used at the remote end of the output circuit must be such as to be suitable for 150 VAC and must have no accessible live parts.

The equipment connected to the output must either be approved to IEC 1010-1 or equivalent or must be suitable for use with an input that may potentially be connected to 150 VAC, and must not catch fire in this circumstance.



WARNING: POSSIBLE EXPLOSION HAZARD

This equipment is not designed for analysis of flammable samples. Introduction of flammable samples into this equipment could result in explosion causing injury, death, or property damage.



WARNING: PARTS INTEGRITY

Tampering or unauthorized substitution of components may adversely affect safety of this product. Use only factory documented components for repair



CAUTION: CAUSTIC MATERIAL

Tampering with the oxygen sensor may result in leakage of the internal liquid electrolyte. The electrolyte is caustic and can cause severe burns to skin. Do not ingest contents of sensor. Read and understand the Material Safety Data Sheets in the rear of this manual before handling the sensor.

ROX GT TRACE OXYGEN ANALYZER

SPECIFICATIONS - GENERAL

RANGES:	0 - 5, 10, 100, 1000 ppm, 0 - 25% Oxygen
SIGNAL OUTPUT:	0-1VDC (10K min) and 4-20 mA DC Isolated (600 ohm max)
ALARMS:	2 Form "C" contact relays, 1 amp @ 30 VDC 1 amp @ 115 VAC
DISPLAY:	3 1/2 Digit Reflective LCD
MIN. DETECTABLE LEVEL:	0.01 ppm
REPEATABILITY:	± 1% of fullscale or .1 ppm whichever is greater
NOISE:	± 1%
LINEARITY:	± 1%
RESPONSE TIME:	90% of fullscale in less than 10 seconds for ranges greater than 0-10 ppm. 90% of fullscale in less than 30 seconds for 0-10 ppm. 90% of fullscale in less than 60 seconds for ranges less than 0-10 ppm.
RECOVERY TIME:	Typically less than 1 hour (air to less than 10 ppm)
ZERO DRIFT:	Less than 1% per week at constant temperature
SPAN DRIFT:	Less than 1% per week at constant temperature
POWER REQUIREMENTS:	115/230 VAC ± 10%, 50/60 Hz, less than 5 W

SPECIFICATIONS - ENVIRONMENTAL

TEMPERATURE RELATED DRIFT:	± 2% of fullscale for temperatures between 15 - 35° C; ± 5% off fullscale over the entire operating temperature range
AMBIENT OPERATING TEMPERATURE:	5 to 45°C
SAMPLE TEMPERATURE:	5 to 45°C
SAMPLE HUMIDITY:	0 to 95% relative humidity non-condensing

SPECIFICATIONS - PHYSICAL

AREA CLASSIFICATION:	General Purpose
GAS CONNECTIONS:	1/4" Swagelok
MOUNTING CONFIGURATION:	1/2 19" or panel mount
PANEL CUTOUT DIMENSIONS:	3.625 X 7.625 inches (92 X 194 mm)
CASE DIMENSIONS:	5.06 X 8.38 X 5.0 inches (129 X 213 X 127 mm) HxWxD
WEIGHT:	Approximately 5 lbs (2.27 Kg)

ROX GP PERCENT OXYGEN ANALYZER

SPECIFICATIONS - GENERAL

RANGES:	0 - 5, 10, 25% Oxygen
SIGNAL OUTPUT:	0-1VDC (10K min) and 4-20 mADC Isolated (600 ohm max)
ALARMS:	2 Form "C" contact relays, 1amp @ 30 VDC 1 amp @ 115 VAC
DISPLAY:	3 1/2 Digit Reflective LCD
MINIMUM DETECTABLE LEVEL:	0.01 % Oxygen
REPEATABILITY:	± 1% of fullscale
NOISE:	± 1%
LINEARITY:	± 1%
RESPONSE TIME:	90% of fullscale in less than 7 seconds (GP1 sensor)
ZERO DRIFT:	Less than 1% per week at constant temperature
SPAN DRIFT:	Less than 1% per week at constant temperature
POWER REQUIREMENTS:	115/230 VAC ± 10%, 50/60 Hz, less than 5 W

SPECIFICATIONS - ENVIRONMENTAL

TEMPERATURE RELATED DRIFT:	± 2% of fullscale for temperatures between 15 - 35°C; ± 5% off fullscale over the entire operating temperature range
AMBIENT OPERATING TEMPERATURE:	5 to 45°C
SAMPLE TEMPERATURE:	5 to 45°C
SAMPLE HUMIDITY:	0 to 95% relative humidity non-condensing

SPECIFICATIONS - PHYSICAL

AREA CLASSIFICATION:	General Purpose
GAS CONNECTIONS:	1/8" Female NPT
MOUNTING CONFIGURATION:	1/2 19" or panel mount
PANEL CUTOUT DIMENSIONS:	3.625 X 7.5 inches (92 X 190 mm)
CASE DIMENSIONS:	5.06 X 8.38 X 5.0 inches (129 X 213 X 127 mm) HxWxD
WEIGHT:	Approximately 5 lbs (2.27 Kg)

CUSTOMER SERVICE, TECHNICAL ASSISTANCE AND FIELD SERVICE

For order administration, replacement Parts, application assistance, on-site or factory repair, service or maintenance contract information, contact:

**Rosemount Analytical Inc.
Process Analytical Division
Customer Service Center
1-800-433-6076**

RETURNING PARTS TO THE FACTORY

Before returning parts, contact the Customer Service Center and request a Returned Materials Authorization (RMA) number. Please have the following information when you call: *Model Number, Serial Number, and Purchase Order Number or Sales Order Number.*

Prior authorization by the factory must be obtained before returned materials will be accepted. Unauthorized returns will be returned to the sender, freight collect.

When returning any product or component that has been exposed to a toxic, corrosive or other hazardous material or used in such a hazardous environment, the user must attach an appropriate Material Safety Data Sheet (M.S.D.S.) or a written certification that the material has been decontaminated, disinfected and/or detoxified.

Return to:

**Rosemount Analytical Inc.
4125 East La Palma Avenue
Anaheim, California 92807-1802**

TRAINING

A comprehensive Factory Training Program of operator and service classes is available. For a copy of the *Current Operator and Service Training Schedule* contact the Technical Services Department at:

**Rosemount Analytical Inc.
Phone: 1-714-986-7600
FAX: 1-714-577-8006**

DOCUMENTATION

The following ROX GT/ROX GP Oxygen Analyzers instruction materials are available. Contact Customer Service or the local representative to order.

748375 Instruction Manual (this document)

COMPLIANCES

This product is approved by the Canadian Standards Association (which is also an OSHA accredited, Nationally Recognized Testing Laboratory), for use in non-hazardous, indoor locations



Rosemount Analytical Inc. has satisfied all obligations from the European Legislation to harmonize the product requirements in Europe.



This product complies with the standard level of NAMUR EMC Recommendation (May 1993).

NAMUR

This product satisfies all obligations of all relevant standards of the EMC framework in Australia and New Zealand.



1 INTRODUCTION

1.1 OVERVIEW

This manual describes the ROX GT trace oxygen analyzer and the ROX GP percent oxygen analyzer of the ROX Series of oxygen analysis instruments.

The ROX GT is designed to determine continuously the concentration of trace oxygen in a flowing gaseous mixture. The concentration is expressed in parts-per-million by volume. The ROX GP is designed to measure continuously the concentration of percent oxygen in a flowing gaseous mixture.

The ROX GT / GP is designed for panel mount or 1/2 19" rack mount, with gas connections made from the rear. All electronic connections are also made from the rear including the AC power input.

1.2 TYPICAL APPLICATIONS

Typical applications for the ROX GT include:

- Monitoring trace oxygen contamination in pure nitrogen or argon streams from air separation facilities.
- Determination of trace oxygen content of inerting atmospheres in heat treat furnaces.
- Monitoring inert atmosphere glove boxes for oxygen impurity

Typical applications for the ROX GP include:

- Measuring percent impurities in pure gases
- Controlling inerting atmospheres in heat treat applications
- Monitoring oxygen enriching or deficient operations

1.3 THEORY OF TECHNOLOGY

The ROX GT / GP uses an electrochemical sensor technology to achieve the measurement of oxygen. See Figure 1-1. The sensor is a self contained disposable unit which requires no maintenance. The sensor utilizes the principle of electrochemical reaction to generate a signal proportional to the oxygen concentration in the sample.

The sensor consists of a cathode and anode which are in contact via a suitable electrolyte. The sensor has a gas permeable membrane which covers the cathode allowing gas to pass into the sensor while preventing liquid electrolyte from leaking out.

As the sample diffuses into the sensor, any oxygen present will dissolve in the electrolyte solution and migrate to the surface of the cathode. The oxygen is reduced at the cathode. Simultaneously, an oxidation reaction is occurring at the anode generating four electrons. These electrons flow to the cathode to reduce the oxygen.

The representative half cell reactions are:

Cathode:

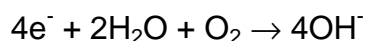

Anode:



The resultant overall cell reaction is:

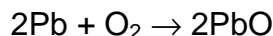

This flow of electrons constitutes an electric current which is directly proportional to the concentration of oxygen present in the sample. In the absence of oxygen, no oxidation / reduction reaction occurs and therefore no current is generated. This allows the sensor to have an absolute zero.

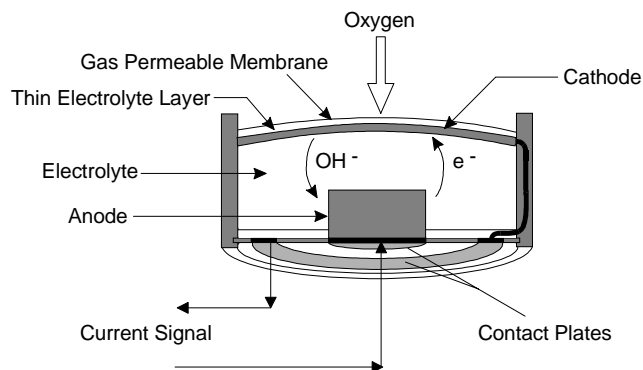

FIGURE 1-1. ELECTROCHEMICAL SENSOR TECHNOLOGY

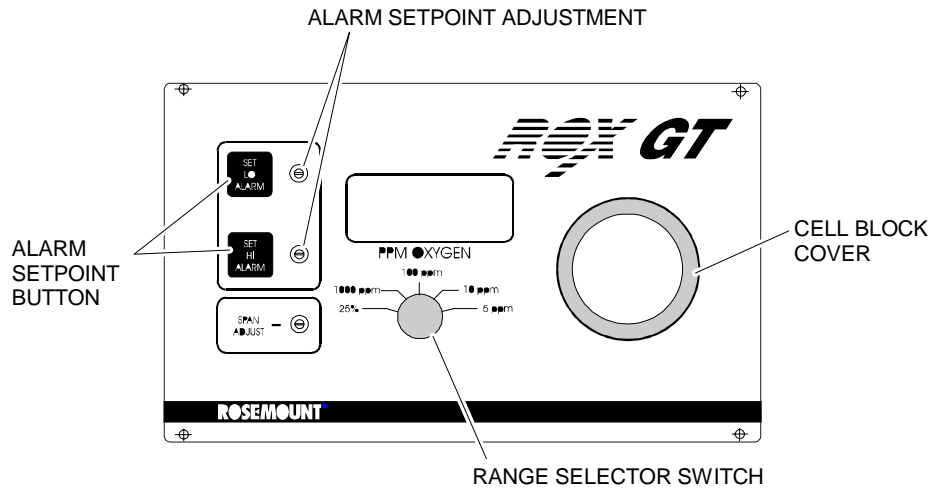

FIGURE 1-2. ROX GT FRONT VIEW

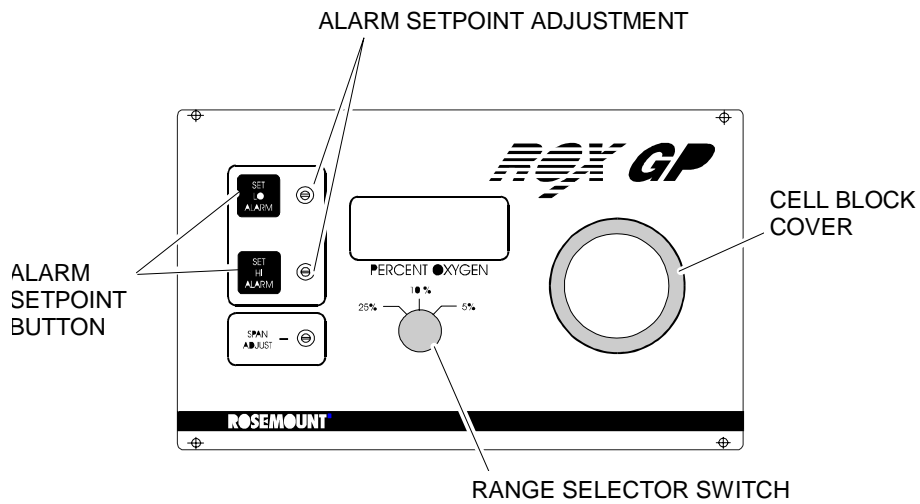

FIGURE 1-3. ROX GP FRONT VIEW

NOTES

2 INSTALLATION

2.1 UNPACKING

Carefully examine the shipping carton and contents for signs of damage. Immediately notify the shipping carrier if the carton or contents is damaged. Retain the carton and packing material until all components associated with the instrument are operational.

2.2 ASSEMBLY

The ROX GT comes fully assembled with sensor installed. Please note that the gas inlet and outlet connections are sealed to prevent exposure of the sensor to air. Prolonged exposure of the sensor to air can cause extended start up time, reduction of performance or damage to the sensor. ***Do not remove the sealing caps until all associated sample handling components are installed and the instrument is fully ready for installation.***

The ROX GP requires that the sensor be installed after the analyzer has been installed and gas connections made.

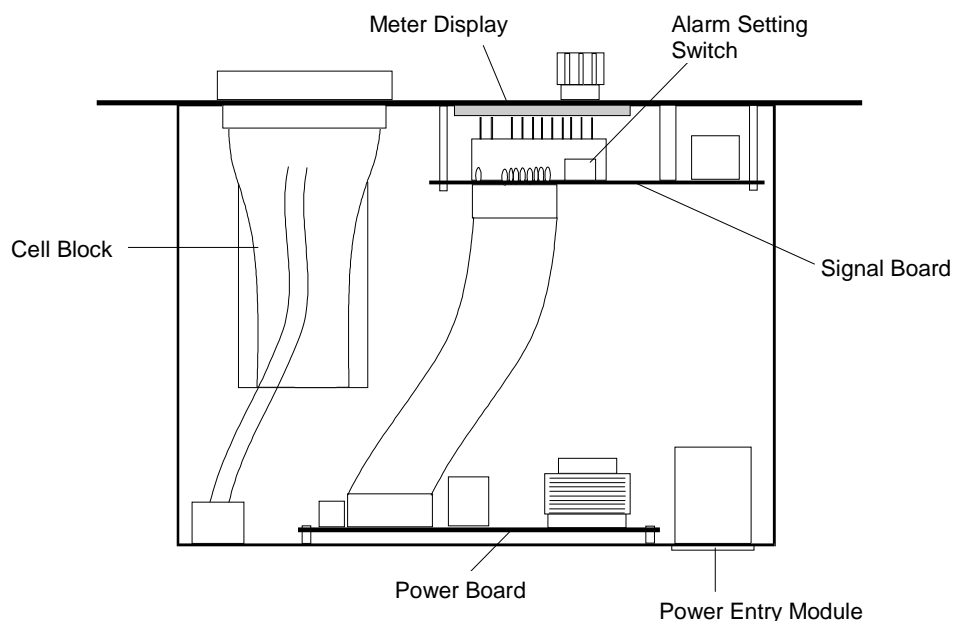

FIGURE 2-1. ROX TOP VIEW (COVER REMOVED)

2.3 LOCATION

Install the ROX GT/GP in a clean, weather-protected, non-hazardous, vibration-free location free from extreme temperature variations. For best results, install the analyzer near the sample take off point to minimize sample transport time.

Operating ambient temperature is 5 °C to 45 °C, limited to temperature changes of less than 10 °C/hr. Acceptable dew point range is less than 95% relative humidity, but not in excess of 45 °C wet bulb temperature.

2.4 GASES

During normal operation, the analyzer requires no support gases. Calibration gases of air or an appropriate mixture of oxygen in nitrogen are recommended (ppm level for ROX GT, % level for ROX GP).

After initial startup or startup following a prolonged shutdown, the analyzer may require extended time to recover to the range of measurement. Commonly, this is caused by the introduction of ambient air into the sample and/or vent lines to the sensor. The presence of higher than normal levels of oxygen at the sensor will cause the sensor electrolyte to become saturated with dissolved oxygen. When the

instrument is placed in operation, the sensor must now consume all excess dissolved oxygen above the desired measuring level. This recovery period is required only for the ROX GT.

All new external gas tubing is strongly recommended, preferably pre-cleaned, stainless steel or copper tubing.

Note

Do not use plastic tubing for trace oxygen measurements as it can permeate oxygen from the ambient air and cause higher than expected oxygen readings.

ROX GT gas line connections are compression fittings. Do not use pipe thread tape. ROX GP gas line connections are female NPT and the use of pipe thread tape is recommended.

2.4.1 CONNECTIONS

See Figure 2-2. Connect sample inlet and outlet lines to appropriately labeled fittings on the rear panel. All connections are 1/4-inch ferrule-type compression fittings on the ROX GT. The ROX GP has 1/8-inch female NPT connections.

If sample is available at positive pressure and flow between .1 and 2 SCFH we recommend following the sample handling configuration shown in Figure 2.3.

If sample is available at ambient pressure or flow is insufficient to meet minimum flow requirements, we recommend following the sample handling configuration shown in Figure 2.4. The inclusion of fast loop bypass, particulate filtration and moisture removal are not shown in these drawings and are the responsibility of the customer to include as required.

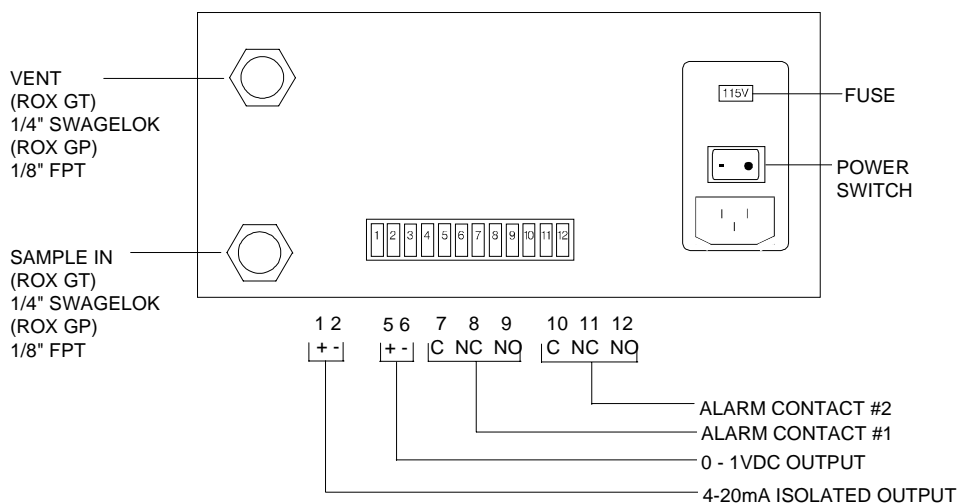

FIGURE 2-2. BACK PANEL CONNECTIONS

2.4.2 GAS SPECIFICATIONS

CALIBRATION GASES

Calibration method and gases depends on the desired operating range, and speed of calibration recovery. Due to the characteristics of the sensor, no zero gas is required. In the absence of oxygen, the sensor has an absolute zero.

Span gas can be either air or a certified blend of known ppm concentration of oxygen in nitrogen. All calibration gases are introduced through the sample inlet at the rear of the module

SAMPLE GAS

Sample gas should be nonflammable (below 100% of the sample's LEL) and inert. Consult factory if sample gas contains CO₂, CO, acid gases, or halogen gases. These samples may not be suitable for use with this analyzer.

FLOW RATE

The sample flow rate can set be between .1 SCFH and 2.0 SCFH (50 - 1000 cc/min) without effecting the accuracy of the sensor. Sample flow should be set at a constant value within these limits which provides the desired response time and sample conservation.

PRESSURE/FILTRATION

Sample pressure at the inlet should be within the range of 0 to 15 psig (1013 to 2048 hPa).

The analyzer does not contain any integral sample filtration. Sample should be filtered for particulates down to five microns to reduce the risk of internal sample line blockage.

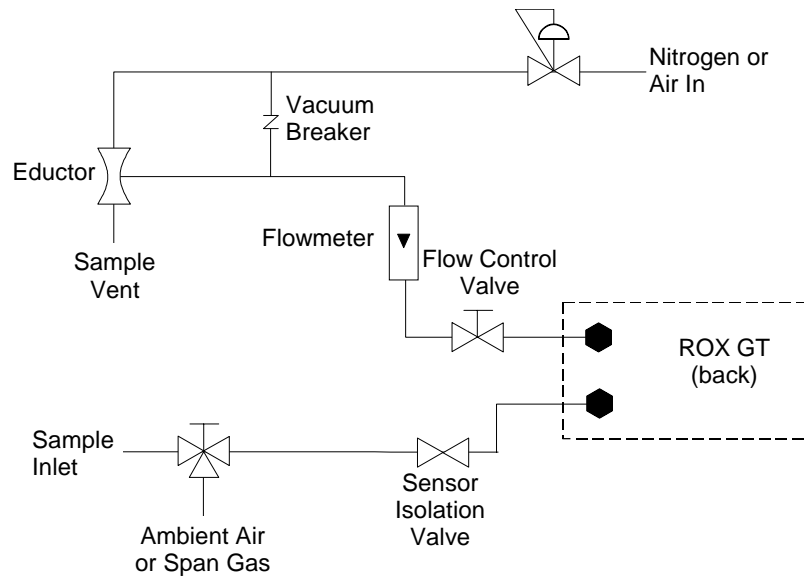

FIGURE 2-3. RECOMMENDED SAMPLE HANDLING DIAGRAM - POSITIVE PRESSURE SAMPLE

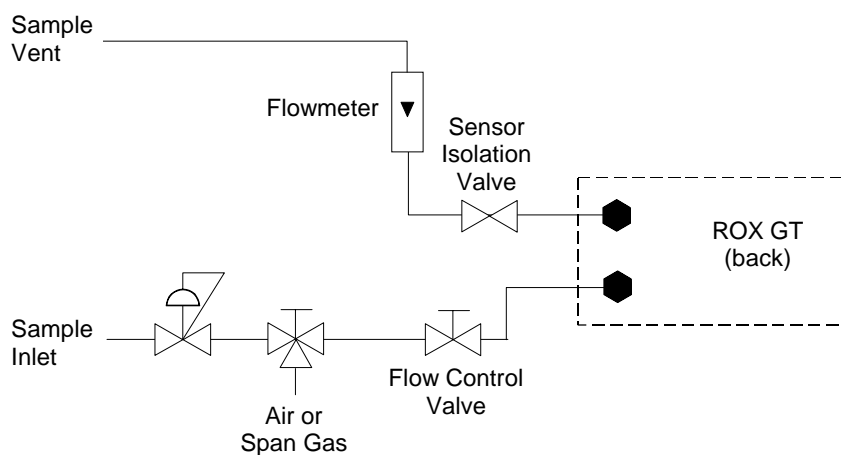

FIGURE 2-4. RECOMMENDED SAMPLE HANDLING DIAGRAM - INSUFFICIENT PRESSURE OR FLOW

2.5 ELECTRICAL CONNECTIONS

All electrical connections can be found on the back of the analyzer (Refer to Figure 2.2).

2.5.1 LINE POWER CONNECTION

The ROX GT/GP is designed to operate on 115 or 230 VAC 50/60 Hz power. The power entry module is located on the right rear panel of the instrument. The power entry module utilizes a standard IEC 320 connector allowing universal connection in all countries by selecting the appropriate line cord at installation. A standard North American power cord is provided with the analyzer.

The analyzer comes configured from the factory for operation on 115 VAC power. If you need to operate the unit on 230 VAC, check to make sure that the unit is disconnected from line power, open the cover door on the power entry module and extract the fuse-block as explained in Section 4.3. Turn the fuse-block over and reinstall so that the "230V" is now visible through the window in the cover door. Close the cover door prior to connecting power.

2.5.2 INTERCONNECTIONS

The analyzer has two kinds of output connections, a signal output and a set of relay contacts. The contacts are rated at 115 VAC, but with the following provisos:

There is only "basic insulation (within the meaning of IEC 1010-1) provided between the contacts and the rest of the circuitry. This means that in the event of a single fault, it is possible that 115 VAC connected to the relay contacts would be connected to the output connections as well. Any equipment connected to the analyzer output may potentially see this 115 VAC.



WARNING: ELECTRICAL SHOCK HAZARD

The output connection is for use only with equipment which has no live parts which are accessible.

The connecting cable and the equipment to which the output is connected must have insulation rated for at least 150 VAC, since under fault condition the output may be connected to the relay contacts witch themselves may be connected to 150 VAC.

The connection used at the remote end of the output circuit must be such as to be suitable for 150 VAC and must have no accessible live parts.

The equipment connected to the output must either be approved to IEC 1010-1 or equivalent or must be suitable for use with an input that may potentially be connected to 150 VAC, and must not catch fire in this circumstance.

Note

The interconnection terminal strip on the rear of the analyzer is designed to be unplugged for easier connection. It is polarized so that you cannot plug it in backwards. Make the connections with plenty of service loop and then plug it in. Double check that you have used the correct terminals, and do not apply a high voltage (e.g. 115 V) to the relay contacts before you have verified that the output connections are correct - putting AC on the signal output will destroy the analyzer.

2.5.3 SIGNAL OUTPUT CONNECTIONS

The analyzer comes standard with both 4-20 mA DC isolated and 0-1 VDC outputs. For ease of installation, the signal output connections are made via a removable terminal strip connector which is shared with the alarm connections (Refer to Figure 2.2).

**WARNING: POSSIBLE EXPLOSION HAZARD**

Check all wiring connections prior to reconnection of the terminal strip. The application of AC power to the signal output terminals will damage the analyzer.

2.5.4 ALARM CONNECTIONS

The analyzer comes standard with two alarms both configured high and normally energized. For ease of installation, the alarm connections are made via a removable terminal strip connector which is shared with the signal output connections (Refer to Figure 2.2). Each set of alarm connections are labeled for easy identification to the associated alarm. The connections labeled NO (normally open), NC (normally closed), and C (common) refer to relay positions with the power removed (de-energized) .

Both alarms are configured from the factory for fail-safe mode (normally energized, and loss of power will cause a change in relay status) and high oxygen setpoint (relay status change above setpoint). To change the alarm configuration, refer to Section 4.5.

2.6 INSTALLATION GUIDELINES

- Is the analyzer's location clean, weather-proofed, non-hazardous, vibration-free, and with a stable ambient temperature?
- Are gas supply cylinders equipped with a clean, metal diaphragm, hydrocarbon free, two stage regulator with shut off valve?

- Are external tubing, regulators, valves, pumps, fittings etc. clean?
- Is the oxygen content of the supply gases compatible with the analysis range?
- Is the sample non-flammable?
- Have all the external gas connections been leaked checked?
- Has clean stainless steel or other appropriate metal tubing been used for sample lines?
- Are all electrical connections secure and correct?
- Has the sensor been installed in the ROX GP?
- Is the proper line input power displayed on the power entry module?

NOTES

3 STARTUP AND OPERATION

3.1 STARTUP

After completion of the installation procedure in Section Two, proceed as follows:

1. Set range switch to the 25% position (full counterclockwise)
2. Turn on power by placing the switch on the power entry module to the “-” position.

3.2 CALIBRATION

See Section 2.4.2 for a description of the method for choosing calibration zero and span gases.

To calibrate the ROX GT/GP, introduce air or span gas into the SAMPLE INLET, and do the following:

1. Set range switch to the 25% range setting (full counterclockwise) or the appropriate range for the span gas used. It is recommended to use the highest concentration span gas which provides you with the best fit for your requirements. The use of air for calibration provides the least chance of span gas error, but does require extended recovery time down to low ppm level measurement.
2. If you have followed the recommended sample handling diagram in Section 2.4.1, open the sensor isolation valve first to avoid exposing the sensor to excessive sample pressure or vacuum. Flow span gas or air at a flow rate between 0.1 and 1.0 L/min. Be careful to not obstruct the outlet as this will cause an increase in sample pressure and a consequent increase in oxygen reading.

Note

Alarm setpoints are not defeated during calibration. Take appropriate precautions during calibration.

3. Wait for reading to stabilize. This should only take a few minutes.
4. Locate the SPAN ADJUST potentiometer on the front panel and adjust appropriately to make the display correspond with the span gas concentration. Turning the potentiometer clockwise will increase the display reading while counterclockwise will decrease the reading.

5. If you have used air to span the instrument, switch to zero gas or sample as soon as possible to avoid prolonged exposure of the sensor to high concentrations of oxygen. The longer the sensor is exposed to air, the longer it will take for the sensor to recover to low ppm levels. When installing a new sensor or starting the instrument for the first time, it may take as long as eight hours for the analyzer to purge down to the lowest operating range.
6. Allow the unit to stabilize at the final reading on zero gas or sample. The unit is now ready for operation.

Unit should be calibrated once a week until familiarity is achieved in required calibration frequency. Calibration intervals as long as once a month are possible on stable installations. Processes which have large changes in environmental conditions and sample composition may require more frequent calibrations.

3.3 OPERATION

After calibration, proceed as follows:

Supply sample gas to the SAMPLE INLET. Adjust external flow controller or throttle valve so that flow discharged from the outlet is between 0.1 and 1.0 L/min.

Note

Flow indication is not provided with the instrument and must be provided external to the analyzer. Refer to installation section for proper location.

When shutting down the instrument, always close the sensor isolation valve last to avoid exposing the sensor to excessive pressure or vacuum.

3.4 ALARM SETPOINTS

The ROX GT/GP come standard with two fully adjustable alarms with relay contacts. These alarm setpoints are designed to operate as percent of range as opposed to discrete concentration value. The alarms are configured from the factory as high and failsafe.

To view the alarm setpoints, turn the range switch to the desired measuring range and press the "SET LO ALARM" or "SET HI ALARM" button. The alarm setpoint will be displayed in actual concentration units. Since the alarms are configured as percent of scale, changing ranges will also change the value of the alarm setpoint. For example, if the LO alarm is set for 5 ppm on the 10 ppm range (50% of range), it will read 50 ppm on the 100 ppm range (50% of range).

To adjust the alarm setpoint, press the appropriate alarm setpoint button, then locate and adjust the associated alarm setpoint adjustment potentiometer as indicated in Figure 1-1. Turning the potentiometer clockwise will increase the setpoint while turning the potentiometer counterclockwise will decrease the setpoint. You must keep the alarm setpoint button depressed during the adjustment procedure to continuously view the alarm setpoint value. Always adjust the "LO" alarm for the lowest setpoint value and the "HI" alarm for the higher value.

4 MAINTENANCE AND TROUBLESHOOTING



CAUTION: QUALIFIED PERSONNEL

This equipment should not be adjusted or repaired by anyone except properly qualified personnel.



WARNING: PARTS INTEGRITY

Tampering with or unauthorized substitution of components may adversely affect the safety and performance of this product. Use only factory approved components for repair.

4.1. MAINTENANCE OVERVIEW

The ROX GT/GP analyzer components which may require replacement include:

- Oxygen sensor
- Power fuse
- Printed circuit boards

4.2 OXYGEN SENSOR REPLACEMENT



CAUTION: CAUSTIC MATERIAL

The sensor contains electrolyte which is caustic and can cause serious burns to skin. Do not ingest contents of sensor. Read and understand the Material Safety Data Sheet in the rear of this manual before handling sensor.

The oxygen sensor used in the ROX GT/GP analyzers is a consumable item and does require replacement periodically. To determine if the sensor requires replacement, see the troubleshooting portion of this section.

SENSOR INSTALLATION

To install a new sensor follow the procedures exactly in the order listed below. Failure to follow the procedure in order may result in extended exposure of the sensor to air causing greater delays in returning to on-line monitoring:

1. Turn off power to unit and turn off sample flow to analyzer.
2. Locate cellblock cover and remove using the key tool provided with instrument. Rotate cover counterclockwise to remove.
3. Inspect cellblock cavity for signs of liquid. If liquid is present, use protective equipment as described in the material safety data sheet in the rear of this manual before proceeding. Extreme care should be used and the liquid should be treated as a corrosive substance.
4. Remove existing sensor and dispose of in accordance with national, federal, state, and local regulations. Use the existing pull-tab on the sensor to remove from the cellblock.
5. Inspect inside of cellblock for signs of residual liquid or deposits on the contact pins. If liquid is present, use appropriate protective equipment and follow the cleanup procedure as described in the material safety data sheet in the rear of this manual. Deposits on the contact pins can be removed by wiping with a damp cloth or using the eraser from a pencil. Do not use abrasives (i.e. sandpaper) as this will damage the contact pins.
6. If sample is inert (e.g., nitrogen) a low flow of sample (50 cc/min) can be introduced to the analyzer to purge out the internal volume of the cellblock prior to installation of the new sensor. This procedure is not required and is recommended as a step to reduce the purge down time of the new sensor.



CAUTION: MAXIMUM FLOW

Do not flow a volume in excess of 50 cc/min. Exceeding this level may produce an oxygen deficient breathing environment to the technician conducting sensor replacement. Do not flow sample if it is flammable or toxic. Do not use this procedure if the sample handling configuration is for insufficient pressure or flow.

7. Inspect the package containing the replacement sensor. ***Do not open the bag.*** Make sure that it is the correct model type and that there is not visible liquid in the bag. If the bag contains liquid, do not open and contact the factory for a replacement.

8. Locate the shorting tab on the back of the sensor. The tab is designed to maintain contact between the two contact plates of the sensor while it is stored in the bag. This contact allows the sensor to continuously consume dissolved oxygen inside the sensor. This clip will need to be removed prior to installing the sensor in the analyzer.
9. Locate the pull-tab portion of the sensor label. When installing the sensor in the cellblock, make sure that this tab faces forward for easy sensor removal later.
10. Cut open the bag being careful not to damage the sensing face of the sensor. Quickly remove the sensor from the bag, remove the shorting clip and install in the cellblock with the contact plates on top and the sensing face on the bottom. Make sure that the pull-tab is facing forward and the writing on the label is right side up (see Figure 4-1).
11. Reinstall the cellblock cover turning clockwise until the O-ring just makes contact. Turn no more than 1/8 turn additional.

Note

Do not overtighten. Doing so may damage the cover.

12. Turn on power and check reading.
13. Calibrate as described in Section 3.2

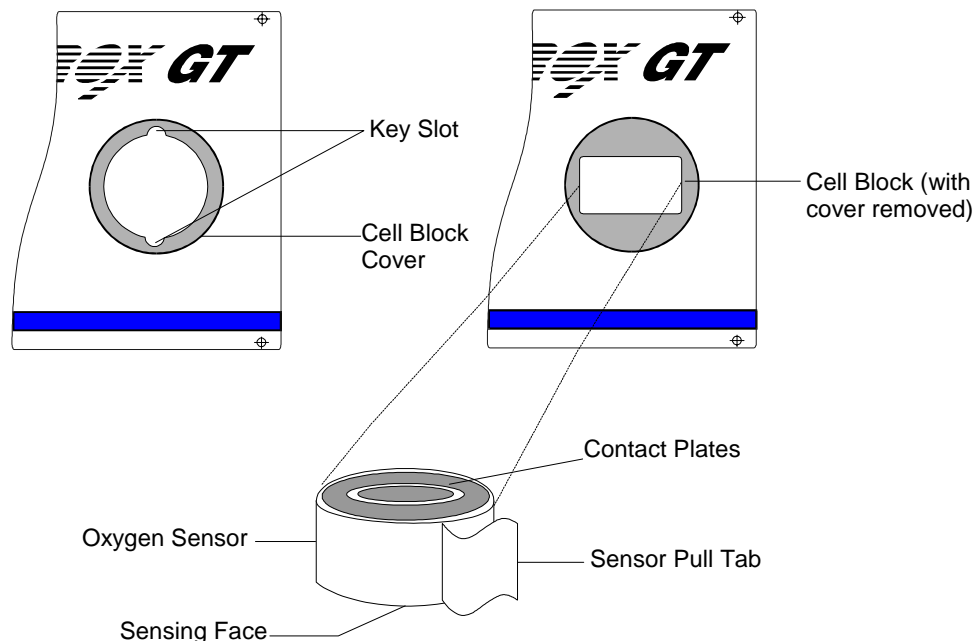

FIGURE 4-1 SENSOR INSTALLATION

4.3 POWER FUSE REPLACEMENT

The ROX GT/GP has the main power fuses located in the power entry module. No other fuses are located inside the instrument.

Before replacing the main power fuse, turn off the analyzer and disconnect the power cord from the power entry module.

Using a small blade slotted screwdriver, carefully pry open the front door of the power entry module. There is a access slot on the top of the module and the door opens downward (see Figure 4-2). Once the door is opened, you can remove the red power selector / fuseholder by inserting the screwdriver into the slot on top of the fuseholder and carefully prying the fuseholder out. The fuseholder contains two 1A fuses. Replace as required.

Reinstall the fuseholder so that the correct voltage is visible through the small window in the door of the power entry module.

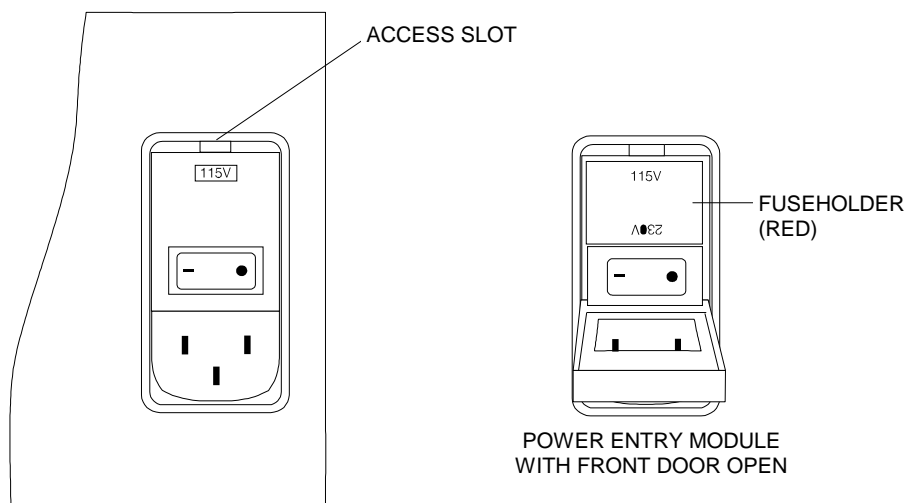

FIGURE 4-2. POWER ENTRY MODULE

4.4 PRINTED CIRCUIT BOARDS

Both printed circuit boards can be replaced if necessary. Refer to Figure 2-1 for the location of the power and signal boards.

4.5 ALARM CONFIGURATION

The alarm setpoints are factory set for high normally energized. If you wish to change the configuration of the alarm setpoints you can do so by the following procedure.

1. Verify that the power module is off and the power cord is disconnected from the analyzer

2. Remove the top cover from the analyzer
3. Locate the signal board as indicated in Figure 2-1
4. Locate the alarm setting dip switches on the signal board
5. To change the alarm setting refer to Figure 4-3 and Table 4-1 for desired configuration

In all cases, "LO ALARM" should be adjusted for the lowest setpoint value and "HI ALARM" should be adjusted for the higher setpoint value.

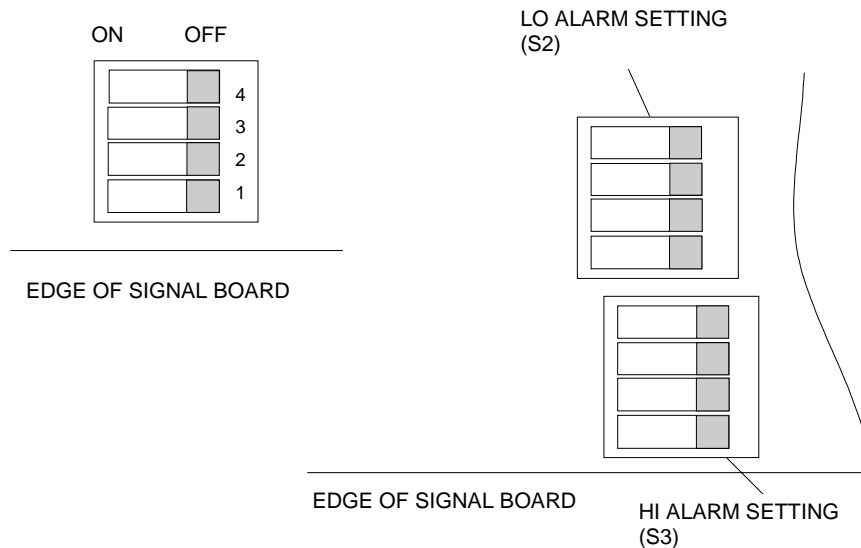

FIGURE 4-3. ALARM SWITCH LOCATION

TRIP POINT - FS/NFS (RELAY STATUS)	SWITCH #			
	1	2	3	4
HIGH - FAILSAFE (NORMALLY ENERGIZED)	OFF	ON	ON	OFF
HIGH - NON FAILSAFE (NORMALLY DE-ENERGIZED)	ON	OFF	OFF	ON
LOW - FAILSAFE (NORMALLY ENERGIZED)	ON	OFF	OFF	ON
LOW - NON FAILSAFE (NORMALLY DE-ENERGIZED)	OFF	ON	ON	OFF

TABLE 4-1. ALARM SETTING CONFIGURATION

4.6 TROUBLESHOOTING

The following provides a short list of common troubleshooting tips.

ANALYZER DOES NOT POWER UP

Check to make sure that the power cord is properly installed and the voltage is correctly selected. The voltage configuration of the analyzer is visible through the window of the power entry module. Make sure that the power switch is in the on position (“-”).

If the unit does not power up, turn off power switch, remove power cord and open door on power entry module as described in Section 4.4 above. Inspect fuses and replace as required.

ANALYZER FAILS TO PURGE DOWN TO PPM LEVELS

The number one problem associated with trace oxygen analyzer installation is the occurrence of leaks in the sample line plumbing. If the oxygen reading will not come down to ppm levels or is reading higher than expected, the sample plumbing prior to the instrument may have a leak. A quick check can be conducted by observing the oxygen reading at two different flow levels; 0.2 and 2.0 SCFH. If the oxygen reading drops significantly when the flow is increased from 0.2 to 2.0 SCFH, this is a good indication that a leak exists.

To check for leaks prior to the sensor, disconnect the analyzer and cap the inlet and outlet fittings on the analyzer to reduce the amount of oxygen exposure to the sensor. Cap the inlet line and pressurize the inlet line to 5 - 10 psig and check all connections with a soapy solution to identify leaks.

**WARNING: POSSIBLE SENSOR DAMAGE**

Do not pressure check the sample line with the sensor/analyzer connected. Over-pressurization of the sensor can result in damage.

If the reading increases with an increase in flow, the vent line may be obstructed causing back pressure on the sensor. Inspect your vent line and remove any devices which may be causing backpressure.

If the reading slowly decreases over time, the sensor may have been exposed to high levels of oxygen for extended periods of time. The sensor must consume all of the dissolved oxygen in the sensor electrolyte before it will accurately measure ppm levels of oxygen. In some cases it is not possible for the sensor to recover to low ppm levels and the sensor must be replaced.

ANALYZER IS READING TOO LOW

Check to make sure that the sensor has been calibrated properly. Flow an appropriate span gas through the instrument and follow the calibration procedure in Section 3.2. If you are unable to achieve span calibration, the sensor has reached the end of its useful life and needs to be replaced (see Section 4.2).

If calibration is possible, but the reading still appears too low, conduct a span check on the 25% range with air. Adjust reading as necessary. If the reading requires adjustment, your bottled span gas may be incorrect or corrupted.

If sensor life seems too short, you may have compounds present in your sample which are poisoning the sensor. Acid gases, CO₂, SO₂, or H₂S can reduce the life of the sensor and should be removed from the sample prior to measuring.

ANALYZER ALWAYS READS ZERO

Check to make sure that the sensor has been installed correctly with the contact plates on top and the gas permeable membrane facing downward. If the sensor has been installed incorrectly, carefully remove and check to make sure that the membrane has not been damaged. If the sensor is leaking, or shows signs of distress to the membrane, replace with a new sensor. If the sensor is okay quickly reinstall in the correct position.

Verify that the cellblock contact pins are making good contact with the metal surfaces of the sensor. If the pins are not making contact, carefully bend the wire down to reestablish contact. Check that the contact pins are clean and do not show signs of deposits or oxidation. Clean as necessary.

A good sensor will have an output of 150 to 500 micro amps in air. You can check this by connecting a DVM across the contact plates of the sensor while it is removed from the instrument and measuring the current. If the sensor does not produce sufficient output, replace the sensor with a new one.

THE READINGS ARE ERRATIC AND DRIFT NOISILY

This is normally an indication that the sensor has reached the end of its useful life. If the analyzer cannot be spanned on a cal gas or air, the sensor must be replaced. If the sensor spans okay and appears stable at high oxygen concentrations, there may be a sample line leak or obstruction of the vent line. Follow the procedure described above in “**Analyzer fails to purge down to ppm levels**”.

If no sample line problems are found, open the cellblock and inspect the sensor for signs of damage or leakage. Follow the procedure in Section 4.2. for correct method of opening cellblock and precautions for handling a leaking sensor.

5 REPLACEMENT PARTS

5.1 ROX REPLACEMENT PARTS



WARNING: PARTS INTEGRITY

Tampering with or unauthorized substitution of components may adversely affect the safety and performance of this product. Use only factory approved components for repair.

5.1.1 REPLACEMENT SENSORS

Refer to Table A-1 in Appendix A for easy cross reference of the correct oxygen sensor for your specific instrument.

658303	Oxygen Sensor GT1
658304	Oxygen Sensor GT3
658310	Oxygen Sensor GP1
658311	Oxygen Sensor GP3
658312	Oxygen Sensor GP4

5.1.2 REPLACEMENT PARTS LIST

904699	Connector Rear Output
658281	Power Cord
904759	Power Supply Board
904760	Cap. Cell Block
904761	O-Ring, Cell Block Cap
904762	Ribbon Cable
904763	Power Entry Module
099393	Fuse 1A 250V
748375	Instruction Manual

ROX GT ONLY

- 904768 Cell Block Assembly
- 904769 Amplifier Board (658301) (658302)

ROX GP ONLY

- 904764 Cell Block Assembly
- 904765 Amplifier Board (658307)
- 904766 Amplifier Board (658308)
- 904767 Amplifier Board (658309)

APPENDIX A. MATERIAL SAFETY DATA SHEETS



The following section contains important information regarding the characteristics of the oxygen sensor used in the ROX GT/GP analyzers. Read and understand all information before attempting any replacement or installation of the oxygen sensor. The following sensor reference guide will provide a quick reference of the specific oxygen sensor type used in your specific analyzer model and part number.

MODEL	INSTRUMENT PART NUMBER	OXYGEN SENSOR MODEL	OXYGEN SENSOR PART NUMBER
ROX GT	658301	GT1	658303
ROX GT	658302	GT3	658304
ROX GP	658307	GP1	658310
ROX GP	658308	GP3	658311
ROX GP	658309	GP4	658312

TABLE A-1. SENSOR REFERENCE GUIDE

NOTES

Material Safety Data Sheet

PRODUCT: OXYGEN SENSOR
PART NUMBER: 658303, 658310, 658312

**24 HOUR EMERGENCY TELEPHONE NUMBER:
 CHEMTREC (800) 424-9300**

SECTION I - GENERAL

Distributor: Rosemount Analytical Inc.
 4125 East La Palma Avenue, CA 92807-1802
 714-986-7600

Chemical name and synonyms	Lead	Potassium Hydroxide
Trade name and synonyms	Lead	Caustic Potash
Chemical family	Inorganic base	Inorganic base
Formula	Pb	KOH
CAS Number	749-92-1	1310-58-3

SECTION II – HAZARDOUS INGREDIENTS

Quantity	3-20 gms	1-5 ml
OSHA PEL	0.05 mg/m ³	None
ACGIH	0.15 mg/m ³	2 mg/m

SECTION III – PHYSICAL DATA

Boiling point	1744°C	1320°C
Melting point	328°C	360°C
Vapor pressure	NA	NA
Vapor density (air=1)	NA	NA
Specific gravity (H ₂ O=1)	11.34	2.04
% Volatile by volume	NA	NA
Evaporation rate (H ₂ O=1)	NA	NA
Solubility in water	Insoluble	Complete
Appearance and odor	Solid, silver gray, odorless	White or slightly yellow, odorless

SECTION IV – FIRE AND EXPLOSION HAZARD DATA

Flash point	NA
Extinguishing media	Appropriate to surrounding fire conditions. No specific agents recommended.
Special fire fighting procedures	Wear NIOSH/OSHA approved self-contained breathing apparatus and protective clothing to prevent contact with skin and eyes.
Unusual fire and explosion hazards	Emits toxic fumes under fire conditions.

SECTION V – REACTIVITY DATA

Stability	Stable
Conditions to avoid	Avoid contact with acids and hydrogen peroxide >52%
Incompatibility (material to avoid)	Aluminum, organic materials, acid chlorides, acid anhydrides, magnesium, copper.
Hazardous decomposition or byproducts	Toxic fumes
Hazardous polymerization	Will not occur

SECTION VI – HEALTH HAZARD DATA

	Lead	Potassium Hydroxide
Threshold limit value	NA	NA
Routes of entry	Inhalation, skin, ingestion	Inhalation, skin, ingestion
Effects of overexposure	<i>Chronic</i> exposure to lead may cause disease of the blood and blood forming organs, kidneys and liver, damage to the reproductive systems and decrease in fertility in men and women, and damage to the fetus of a pregnant woman. <i>Chronic exposure from the lead contained in this product is extremely unlikely.</i>	<i>Acute Effects:</i> Corrosive to tissue. May cause irritation or chemical burns to skin and eyes. Harmful if swallowed, inhaled or absorbed through the skin. <i>Chronic Effects:</i> Prolonged exposure has a destructive effect on tissue.
Emergency & first aid procedures	<i>Eyes and skin</i> - immediately flush with water for at least fifteen minutes. Remove contaminated clothing. Call a physician. ORAL INGESTION - DO NOT INDUCE VOMITING. If person is conscious, give quantities of milk or water. Call a physician immediately and take patient to hospital emergency room.	

SECTION VII – SPILL OR LEAK PROCEDURE

NOTE: The oxygen sensors are sealed, and under normal circumstances, the contents of the sensors do not present a health hazard. The following information is given as a guide in the event that a cell leaks.

Steps to be taken in case material is released or spilled	Wipe down the area several times, each time with a fresh, wet paper towel. Contaminated paper towels are considered hazardous waste.
Waste disposal method	Both lead and potassium hydroxide are considered poisonous substances and are regulated under TSCA and SARA Title III. EPA Waste Number: D008 California Waste Number: 181 DOT Information: RQ Hazardous Waste Solid N.O.S. (Lead), 9, UN3077, PG III. Follow all Federal, State and Local regulations.

SECTION VIII – SPECIAL PROTECTION INFORMATION

Respiratory protection	NA
Ventilation	NA
Protective gloves	Rubber gloves.
Eye protection	Chemical splash goggles.
Other protective equipment	Apron, face shield

SECTION IX – SPECIAL PRECAUTIONS

Precautions to be taken in handling and storing	Protective measures during cell replacement: Before opening the bag containing the sensor cell, check the sensor cell for leakage. If sensor cell leaks, do not open the bag. If liquid is present around cell while in the instrument, wear eye and hand protection.
Other precautions	none

SECTION X – TRANSPORTATION

Must be compliance with federal, state and local regulations

NOTICE: WHILE ROSEMOUNT ANALYTICAL BELIEVES THE INFORMATION CONTAINED HEREIN IS VALID AND ACCURATE, ROSEMOUNT ANALYTICAL MAKES NO WARRANTY OR REPRESENTATION AS TO ITS VALIDITY, ACCURACY, OR CURRENCY. ROSEMOUNT ANALYTICAL SHALL NOT BE LIABLE OR OTHERWISE RESPONSIBLE IN ANY WAY FOR USE OF EITHER THIS INFORMATION OR THE MATERIAL TO WHICH IT APPLIES. DISPOSAL OF HAZARDOUS MATERIAL MAY BE SUBJECT TO FEDERAL, STATE, OR LOCAL LAWS AND/OR REGULATIONS.

Material Safety Data Sheet

PRODUCT: OXYGEN SENSOR, MODEL GT3
PART NUMBER: 658304

**24 HOUR EMERGENCY TELEPHONE NUMBER:
 CHEMTREC (800) 424-9300**

SECTION I - GENERAL

Distributor: Rosemount Analytical Inc.
 4125 East La Palma Avenue, CA 92807-1802
 714-986-7600

Chemical name and synonyms	acetic acid (5% v/v)	potassium acetate (5% w/v)	lead (pure)
Trade name and synonyms	acetic acid	potassium acetate	lead
Chemical family	inorganic acid	inorganic base	inorganic base
Formula	HC ₂ H ₃ O ₂	KC ₂ H ₃ O ₂	Pb
CAS Number	64-19-7	127-08-2	7439-92-1

SECTION II – HAZARDOUS INGREDIENTS

Hazardous mixtures of other liquids, solids or gases none

SECTION III – PHYSICAL DATA

Boiling point	118°C	NA	1744°C
Melting point	16.6°C	292°C	328°C
Vapor pressure	NA	NA	NA
Vapor density (air=1)	NA	NA	NA
Specific gravity (H ₂ O=1)	1.05	1.57	11.34
% Volatile by volume	NA	NA	NA
Evaporation rate (H ₂ O=1)	NA	NA	NA
Solubility in water	Infinite	72%	Insoluble
Appearance and odor	Clear, odorless solution w/strong vinegar-like odor	White, odorless crystal	Grey, odorless

SECTION IV – FIRE AND EXPLOSION HAZARD DATA¹

Flash point	NA	NA	NA
Extinguishing media	NA	NA	NA
Special fire fighting procedures	NA	NA	NA
Unusual fire and explosion hazards	NA	NA	NA

SECTION V – REACTIVITY DATA

Stability	In sensor, stable under normal conditions of use.
Conditions to avoid	Avoid contact between sensor electrolyte and strong acids and oxidizing agents.
Incompatibility (material to avoid)	NA
Hazardous decomposition or byproducts	NA
Hazardous polymerization	will not occur

¹ The electrolyte in the Model GT3 Oxygen Sensor is not flammable. There are not fire or explosion hazards associated with this sensor.

SECTION VI – HEALTH HAZARD DATA

Threshold limit value	10 ppm (TWA) 15 ppm (STEL)	NA	0.15 mg/cu.m
Routes of entry	Skin, eyes, ingestion. Liquid inhalation highly unlikely.		
Effects of overexposure	<p><i>Eyes</i> - The electrolyte is corrosive; eye contact could result in permanent loss of vision.</p> <p><i>Skin</i> - The electrolyte is corrosive; skin contact could result in a chemical burn.</p> <p><i>Ingestion</i> - The electrolyte could be harmful or fatal if swallowed.</p>		
Emergency & first aid procedures	<p><i>Eyes</i> - Flush eyes with water for at least 15 minutes and get immediate medical attention.</p> <p><i>Skin</i> - Wash affected area with plenty of water and remove contaminated clothing. If burning persists, seek medical attention.</p> <p><i>Ingestion</i> - Give plenty of cold water. DO NOT INDUCE VOMITING. Seek medical attention.</p>		

SECTION VII – SPILL OR LEAK PROCEDURE

NOTE: THE OXYGEN SENSORS ARE SEALED, AND UNDER NORMAL CIRCUMSTANCES, THE CONTENTS OF THE SENSORS DO NOT PRESENT A HEALTH HAZARD. THE FOLLOWING INFORMATION IS GIVEN AS A GUIDE IN THE EVENT THAT A CELL LEAKS.

Steps to be taken in case material is released or spilled	Wipe down the area several times with a wet paper towel. Use a fresh towel each time.
Waste disposal method	Should be in accordance with all applicable state, local and federal regulations.

SECTION VIII – SPECIAL PROTECTION INFORMATION

Respiratory protection	NA
Ventilation	NA
Protective gloves	Rubber gloves
Eye protection	Chemical splash goggles
Other protective equipment	approved working clothes

SECTION IX – SPECIAL PRECAUTIONS

Precautions to be taken in handling and storing	During cell replacement, before opening the bag containing the sensor cell, check the sensor cell for leakage. If the sensor cell leaks, do not open the bag. If there is liquid around the cell while in the instrument, put on gloves and eye protection before removing the cell.
Other precautions	none

SECTION X – TRANSPORTATION

Must be compliance with federal, state and local regulations

NOTICE: WHILE ROSEMOUNT ANALYTICAL BELIEVES THE INFORMATION CONTAINED HEREIN IS VALID AND ACCURATE, ROSEMOUNT ANALYTICAL MAKES NO WARRANTY OR REPRESENTATION AS TO ITS VALIDITY, ACCURACY, OR CURRENCY. ROSEMOUNT ANALYTICAL SHALL NOT BE LIABLE OR OTHERWISE RESPONSIBLE IN ANY WAY FOR USE OF EITHER THIS INFORMATION OR THE MATERIAL TO WHICH IT APPLIES. DISPOSAL OF HAZARDOUS MATERIAL MAY BE SUBJECT TO FEDERAL, STATE, OR LOCAL LAWS AND/OR REGULATIONS.

Material Safety Data Sheet

PRODUCT: OXYGEN SENSOR, MODEL GP3
PART NUMBER: 658311

**24 HOUR EMERGENCY TELEPHONE NUMBER:
 CHEMTREC (800) 424-9300**

SECTION I - GENERAL

Distributor: Rosemount Analytical Inc.
 4125 East La Palma Avenue, CA 92807-1802
 714-986-7600

Chemical name and synonyms	potassium dibasic phosphate (1.78% w/v)	potassium bicarbonate (5.11% w/v)	lead (pure)
Trade name and synonyms	potassium dibasic phosphate	potassium bicarbonate	lead
Chemical family	inorganic base	inorganic base	inorganic base
Formula	K ₂ HPO ₄ • 3H ₂ O	KHCO ₃	Pb
CAS Number	16788-57-1	198-14-6	7439-92-1

SECTION II – HAZARDOUS INGREDIENTS

Hazardous mixtures of other liquids, solids or gases none

SECTION III – PHYSICAL DATA

Boiling point	118°C	NA	1744°C
Melting point	16.6°C	292°C	328°C
Vapor pressure	NA	NA	NA
Vapor density (air=1)	NA	NA	NA
Specific gravity (H ₂ O=1)	1.05	1.57	11.34
% Volatile by volume	NA	NA	NA
Evaporation rate (H ₂ O=1)	NA	NA	NA
Solubility in water	Infinite	72%	Insoluble
Appearance and odor	Clear, odorless solution w/strong vinegar-like odor	White, odorless crystal	Grey, odorless

SECTION IV – FIRE AND EXPLOSION HAZARD DATA¹

Flash point	NA
Extinguishing media	NA
Special fire fighting procedures	NA
Unusual fire and explosion hazards	NA

SECTION V – REACTIVITY DATA

Stability	In sensor, stable under normal conditions of use.
Conditions to avoid	Avoid contact between sensor electrolyte and strong acids and oxidizing agents.
Incompatibility (material to avoid)	NA
Hazardous decomposition or byproducts	NA
Hazardous polymerization	will not occur

¹ The electrolyte in the Model GP3 Oxygen Sensor is not flammable. There are not fire or explosion hazards associated with this sensor.

SECTION VI – HEALTH HAZARD DATA

Threshold limit value	NA
Routes of entry	Skin, eyes, ingestion. Liquid inhalation highly unlikely.
Effects of overexposure	<i>Eyes</i> - The electrolyte is corrosive; eye contact could result in permanent loss of vision. <i>Skin</i> - The electrolyte is corrosive; skin contact could result in a chemical burn. <i>Ingestion</i> - The electrolyte could be harmful or fatal if swallowed.
Emergency & first aid procedures	<i>Eyes</i> - Flush eyes with water for at least 15 minutes and get immediate medical attention. <i>Skin</i> - Wash affected area with plenty of water and remove contaminated clothing. If burning persists, seek medical attention. <i>Ingestion</i> - Give plenty of cold water. DO NOT INDUCE VOMITING. Seek medical attention.

SECTION VII – SPILL OR LEAK PROCEDURE

NOTE: THE OXYGEN SENSORS ARE SEALED, AND UNDER NORMAL CIRCUMSTANCES, THE CONTENTS OF THE SENSORS DO NOT PRESENT A HEALTH HAZARD. THE FOLLOWING INFORMATION IS GIVEN AS A GUIDE IN THE EVENT THAT A CELL LEAKS.

Steps to be taken in case material is released or spilled	Wipe down the area several times with a wet paper towel. Use a fresh towel each time.
Waste disposal method	Should be in accordance with all applicable state, local and federal regulations.

SECTION VIII – SPECIAL PROTECTION INFORMATION

Respiratory protection	NA
Ventilation	NA
Protective gloves	Rubber gloves
Eye protection	Chemical splash goggles
Other protective equipment	approved working clothes

SECTION IX – SPECIAL PRECAUTIONS

Precautions to be taken in handling and storing	During cell replacement, before opening the bag containing the sensor cell, check the sensor cell for leakage. If the sensor cell leaks, do not open the bag. If there is liquid around the cell while in the instrument, put on gloves and eye protection before removing the cell.
Other precautions	none

SECTION X – TRANSPORTATION

Must be compliance with federal, state and local regulations

NOTICE: WHILE ROSEMOUNT ANALYTICAL BELIEVES THE INFORMATION CONTAINED HEREIN IS VALID AND ACCURATE, ROSEMOUNT ANALYTICAL MAKES NO WARRANTY OR REPRESENTATION AS TO ITS VALIDITY, ACCURACY, OR CURRENCY. ROSEMOUNT ANALYTICAL SHALL NOT BE LIABLE OR OTHERWISE RESPONSIBLE IN ANY WAY FOR USE OF EITHER THIS INFORMATION OR THE MATERIAL TO WHICH IT APPLIES. DISPOSAL OF HAZARDOUS MATERIAL MAY BE SUBJECT TO FEDERAL, STATE, OR LOCAL LAWS AND/OR REGULATIONS.

GENERAL PRECAUTIONS FOR HANDLING AND STORING HIGH PRESSURE GAS CYLINDERS

*Edited from selected paragraphs of the Compressed
Gas Association's "Handbook of Compressed Gases"
published in 1981*

*Compressed Gas Association
1235 Jefferson Davis Highway
Arlington, Virginia 22202
Used by Permission*

1. Never drop cylinders or permit them to strike each other violently.
2. Cylinders may be stored in the open, but in such cases, should be protected against extremes of weather and, to prevent rusting, from the dampness of the ground. Cylinders should be stored in the shade when located in areas where extreme temperatures are prevalent.
3. The valve protection cap should be left on each cylinder until it has been secured against a wall or bench, or placed in a cylinder stand, and is ready to be used.
4. Avoid dragging, rolling, or sliding cylinders, even for a short distance; they should be moved by using a suitable hand-truck.
5. Never tamper with safety devices in valves or cylinders.
6. Do not store full and empty cylinders together. Serious suckback can occur when an empty cylinder is attached to a pressurized system.
7. No part of cylinder should be subjected to a temperature higher than 125°F (52°C). A flame should never be permitted to come in contact with any part of a compressed gas cylinder.
8. Do not place cylinders where they may become part of an electric circuit. When electric arc welding, precautions must be taken to prevent striking an arc against the cylinder.

(blank)

WARRANTY

Goods and part(s) (excluding consumables) manufactured by Seller are warranted to be free from defects in workmanship and material under normal use and service for a period of twelve (12) months from the date of shipment by Seller. Consumables, glass electrodes, membranes, liquid junctions, electrolyte, o-rings, etc., are warranted to be free from defects in workmanship and material under normal use and service for a period of ninety (90) days from date of shipment by Seller. Goods, part(s) and consumables proven by Seller to be defective in workmanship and/or material shall be replaced or repaired, free of charge, F.O.B. Seller's factory provided that the goods, part(s) or consumables are returned to Seller's designated factory, transportation charges prepaid, within the twelve (12) month period of warranty in the case of goods and part(s), and in the case of consumables, within the ninety (90) day period of warranty. This warranty shall be in effect for replacement or repaired goods, part(s) and the remaining portion of the ninety (90) day warranty in the case of consumables. A defect in goods, part(s) and consumables of the commercial unit shall not operate to condemn such commercial unit when such goods, part(s) and consumables are capable of being renewed, repaired or replaced.

The Seller shall not be liable to the Buyer, or to any other person, for the loss or damage directly or indirectly, arising from the use of the equipment or goods, from breach of any warranty, or from any other cause. All other warranties, expressed or implied are hereby excluded.

IN CONSIDERATION OF THE HEREIN STATED PURCHASE PRICE OF THE GOODS, SELLER GRANTS ONLY THE ABOVE STATED EXPRESS WARRANTY. NO OTHER WARRANTIES ARE GRANTED INCLUDING, BUT NOT LIMITED TO, EXPRESS AND IMPLIED WARRANTIES OR MERCHANTABILITY AND FITNESS FOR A PARTICULAR PURPOSE.

Limitations of Remedy. SELLER SHALL NOT BE LIABLE FOR DAMAGES CAUSED BY DELAY IN PERFORMANCE. THE SOLE AND EXCLUSIVE REMEDY FOR BREACH OF WARRANTY SHALL BE LIMITED TO REPAIR OR REPLACEMENT UNDER THE STANDARD WARRANTY CLAUSE. IN NO CASE, REGARDLESS OF THE FORM OF THE CAUSE OF ACTION, SHALL SELLER'S LIABILITY EXCEED THE PRICE TO BUYER OF THE SPECIFIC GOODS MANUFACTURED BY SELLER GIVING RISE TO THE CAUSE OF ACTION. BUYER AGREES THAT IN NO EVENT SHALL SELLER'S LIABILITY EXTEND TO INCLUDE INCIDENTAL OR CONSEQUENTIAL DAMAGES. CONSEQUENTIAL DAMAGES SHALL INCLUDE, BUT ARE NOT LIMITED TO, LOSS OF ANTICIPATED PROFITS, LOSS OF USE, LOSS OF REVENUE, COST OF CAPITAL AND DAMAGE OR LOSS OF OTHER PROPERTY OR EQUIPMENT. IN NO EVENT SHALL SELLER BE OBLIGATED TO INDEMNIFY BUYER IN ANY MANNER NOR SHALL SELLER BE LIABLE FOR PROPERTY DAMAGE AND/OR THIRD PARTY CLAIMS COVERED BY UMBRELLA INSURANCE AND/OR INDEMNITY COVERAGE PROVIDED TO BUYER, ITS ASSIGNS, AND EACH SUCCESSOR INTEREST TO THE GOODS PROVIDED HEREUNDER.

Force Majeure. Seller shall not be liable for failure to perform due to labor strikes or acts beyond Seller's direct control.

Rosemount Analytical

Rosemount Analytical Inc.

4125 EAST LA PALMA AVENUE • ANAHEIM, CALIFORNIA 92807-1802 • 714-986-7600 • FAX 714-577-8006
FEBRUARY 1997 • 7485189-C • PRINTED IN USA

(blank)

FIELD SERVICE AND REPAIR FACILITIES

Field service and repair facilities are located worldwide.

U.S.A.

To obtain field service on-site or assistance with a service problem, contact (24 hours, 7 days a week):

**National Response Center
1-800-654-7768**

INTERNATIONAL

Contact your local Rosemount Sales and Service office for service support.

FACTORY

For order administration, replacement Parts, application assistance, on-site or factory repair, service or maintenance contract information, contact:

**Rosemount Analytical Inc.
Process Analytical Division
Customer Service Center
1-800-433-6076**

RETURNING PARTS TO THE FACTORY

Before returning parts, contact the Customer Service Center and request a Returned Materials Authorization (RMA) number. Please have the following information when you call: *Model Number, Serial Number, and Purchase Order Number or Sales Order Number.*

Prior authorization by the factory must be obtained before returned materials will be accepted. Unauthorized returns will be returned to the sender, freight collect.

When returning any product or component that has been exposed to a toxic, corrosive or other hazardous material or used in such a hazardous environment, the user must attach an appropriate Material Safety Data Sheet (M.S.D.S.) or a written certification that the material has been decontaminated, disinfected and/or detoxified.

Return to:

**Rosemount Analytical Inc.
4125 East La Palma Avenue
Anaheim, California 92807-1802**

(blank)

Rosemount Analytical

ADDENDUM

MODELS ROX GT, ROX GP OXYGEN ANALYZERS INSTRUCTION MANUAL 748375

1.0 OVERVIEW

This addendum serves as an amendment to the Models ROX GT and ROX GP Oxygen Analyzers instruction manual (PN 748375).

The following information should be considered part of the manual, and supersedes any conflicting information in the body of the manual.

READ THIS INFORMATION AND NOTE THE CONFLICTS

2.0 24 VDC ELECTRICAL CONNECTIONS

The ROX GT 24 VDC Analyzer (PN 658301-24) is designed to operate on 24 VDC input.

Prior to making electrical connections to the analyzer, verify that the power rating on the instrument name-rating label is correct.

The 24 VDC electrical connection is located on the right rear panel of the instrument. The terminal strip is labeled: (Refer to Figure 1.)

+	+24 VDC
-	-24 VDC
⊥	Ground



WARNING: POSSIBLE ELECTRICAL DAMAGE

Connection of AC voltage to the power input connections will result in serious damage to the analyzer. Verify all electrical input connections for correct voltage and power before powering up analyzer.

Rosemount Analytical Inc.

4125 EAST LA PALMA AVENUE • ANAHEIM, CALIFORNIA 92807-1802 • TEL 714-986-7600 • FAX 714-577-8006

JULY 1998 • 748399-A • PRINTED IN USA

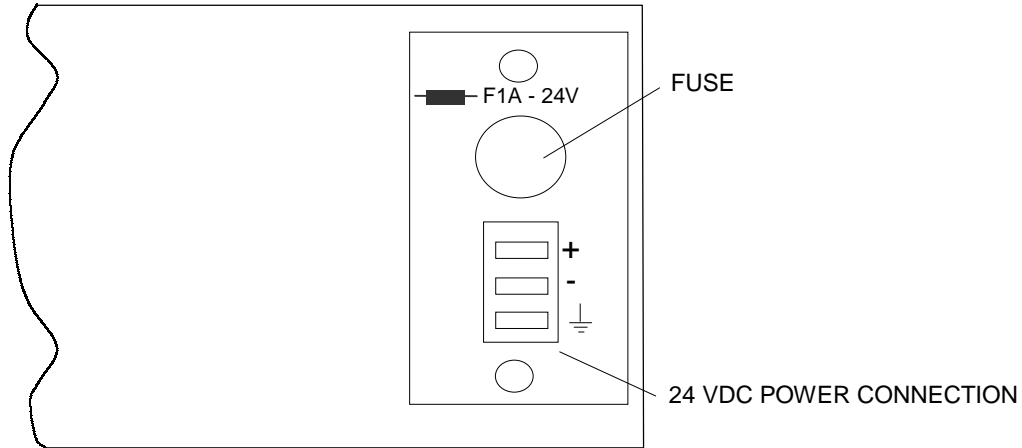

FIGURE 1. REAR PANEL ELECTRICAL INPUT CONNECTION

3.0 POWER FUSE REPLACEMENT

The ROX GT 24 VDC Analyzer has the main power fuse located directly above the electrical power input terminal strip on the rear panel. No other fuses are located in the analyzer.

Before replacing the main power fuse, turn off and disconnect electrical power to the analyzer.

The fuseholder utilizes a standard twist-off cap. To replace the fuse, rotate the fuseholder cap counterclockwise until the cap is free from the body. The fuse will come out with the cap. Replace fuse and re-install cap onto fuseholder.