

Power source wiring

Follow these precautions when installing power source wiring:

1. All wiring, as well as circuit breaker or power-disconnect switch locations, must conform to the CEC or NEC; all local, state, or other jurisdictions; and company standards and practices.
2. **Provide single-phase, three-wire power at 120 or 240 VAC, 50-60 Hertz.**

Note: You cannot use a three-phase AC power source with the 1500XA; the transformer cannot support the current load.

Note: If you do not have a single phase, three-wire AC power source, you must purchase an isolation transformer. See the schematic on the following page for more information.

3. Locate in a safe area.
4. Provide the 700XA and any optionally installed devices with one 15-amp circuit breaker for protection.

CAUTION

15 amps is the maximum current for 14 AWG (wire).

5. Ensure that the 24 VDC input power is compliant with the Separated Extra-Low Voltage (SELV) standard by ensuring suitable electrical separation from other circuits.

6. Use multi-stranded copper conductor wire according to the following recommendations:
 - For power feed distances up to 250 feet (76 meters), use 14 AWG (American Wire Gauge) (18 Metric Wire Gauge), stranded.
 - For power feed distances 250 to 500 feet (76 to 152 meters), use 12 AWG (25 Metric Wire Gauge), stranded.
 - For power feed distances 500 to 1000 feet (152 to 305 meters), use 10 AWG (30 Metric Wire Gauge), stranded.
 - Cable entries are M32 in accordance with ISO 965.

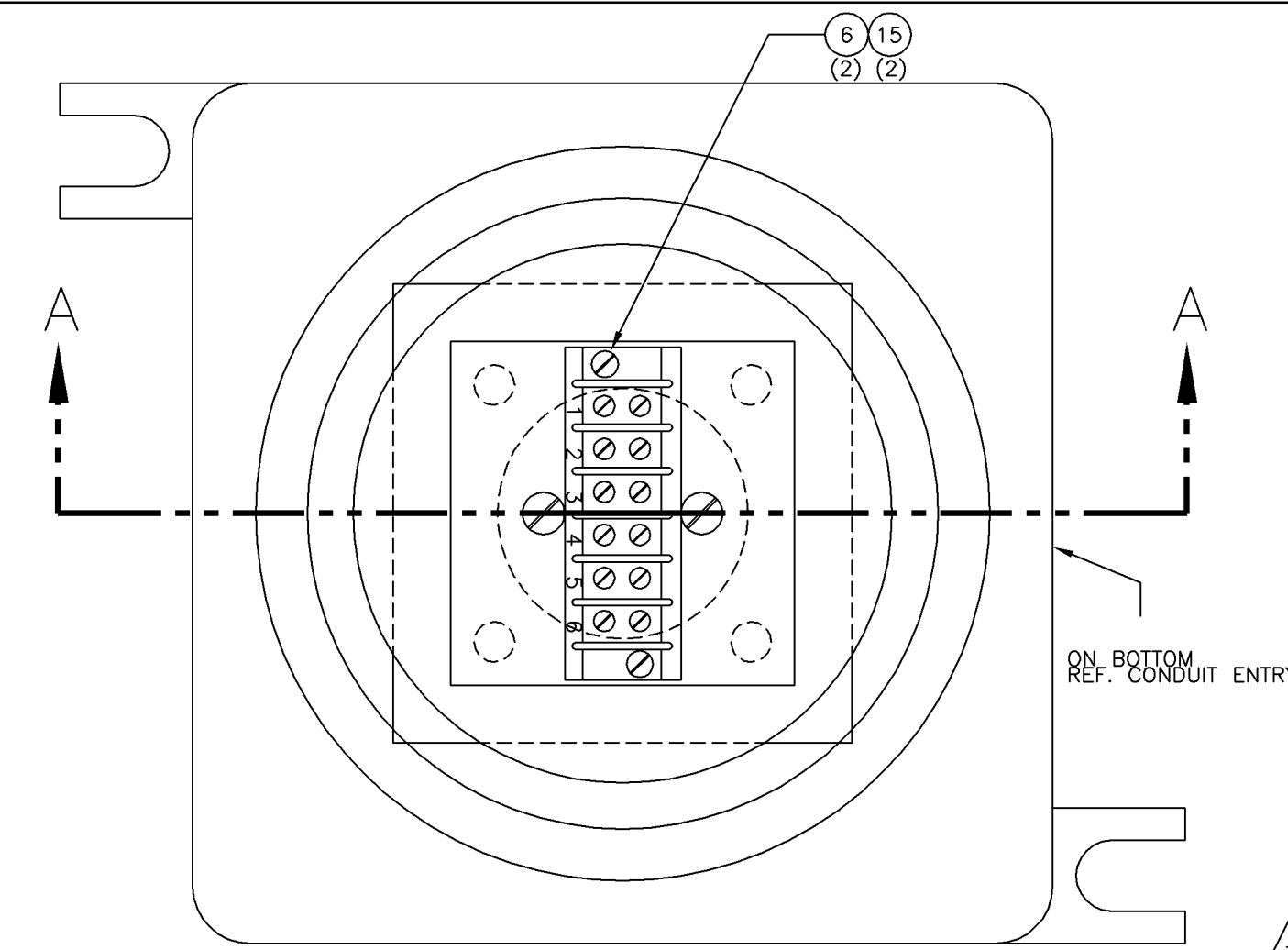

- NOTES:
1. THE FIRST STEP IN THE ASSEMBLY REQUIRES THAT THE STANDOFFS (ITEM 10) BE MOUNTED ON LOWER PLATE (ITEM 4) AND THEN THE PLATE IS TO BE MOUNTED IN THE ENCLOSURE BEFORE THE REMAINING ITEMS ARE TO BE ASSEMBLED.
 2. WIRE TRANSFORMER TO TERMINAL STRIP PER WIRING DIAGRAM USING TERMINAL LUGS (ITEM 14). JUMPER FOR 230 VAC PER TABLE. USE TERMINAL LUGS (ITEM 18) FOR JUMPERS AND INPUT/OUTPUT WIRING. PUT EXTRA (6) TERMINAL LUGS (ITEM 18) IN BAG AND TAPE TO INSIDE OF ENCLOSURE LID.
 3. INSTALL SHRINK TUBING (ITEM 16) ON THE ENTIRE LENGTH OF (2) STANDOFFS (ITEM 10).

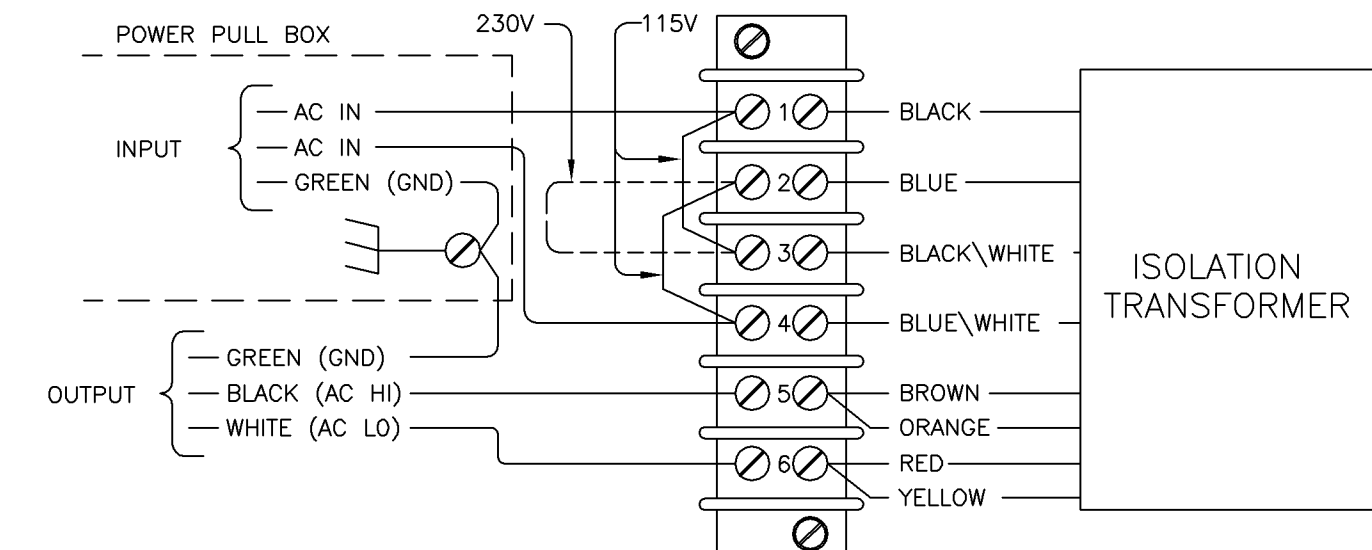
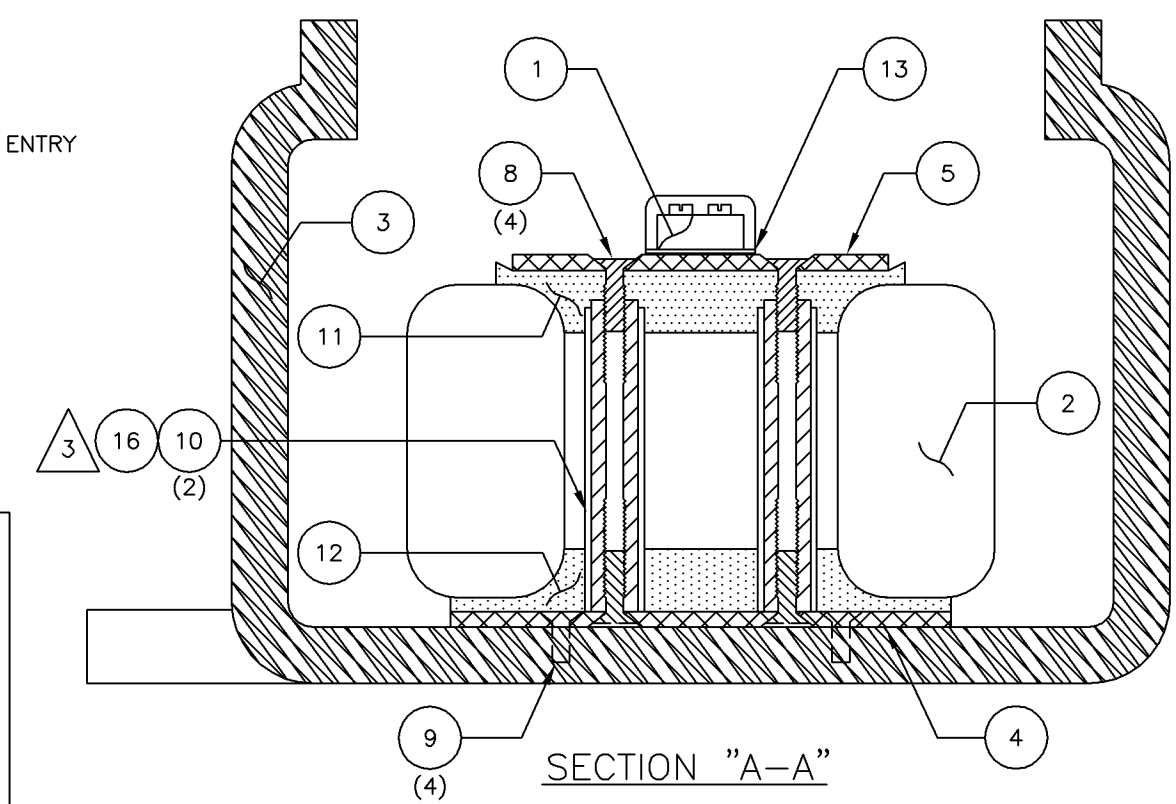

CONNECT JUMPERS PER CHART

INPUT	OUTPUT	JUMPER #1	JUMPER #2
230V	115V	2-3	NONE
115V	115V	1-3	2-4

SI METRIC						
THIRD ANGLE PROJECTION						
MATERIAL SEE ORDER	E	11-09-07	CC	ECO-XX-5003273	EM	HS
	D	3-05-03	HM	ECO-XX-166401	EM	DLT
	C	4/3/98	RD	ECO-9433	EM	DLT
	B	6/97	RD	ECO-9194	EM	DLT
	A	3/20/97	RD	ECO-9092	EM	DLT
FINISH SEE ORDER	REV	DATE	DRN	DESCRIPTION	CHKD	APPD
PROJ. FILE NO. - NONE	FILENAME: CE19492E1.dwg, DATE: 11-09-07, TIME: 2:05 P.M.					

THIS DRAWING IN DESIGN AND DETAIL IS OUR PROPERTY AND MUST NOT BE USED EXCEPT IN CONNECTION WITH OUR WORK. IT SHALL NOT BE REPRODUCED AND SHALL BE RETURNED TO US ON DEMAND. ALL RIGHTS ARE RESERVED.

GEOMETRIC TOLERANCES & DIMENSIONS PER ANSI Y14.5 LATEST REVISION

UNLESS OTHERWISE NOTED ALL DIMENSIONS IN INCHES
 X.XX ±.015
 X.XXX ±.005
 ANGULAR 30° 30'
 FINISH 200 RA MAX

BREAK ALL SHARP CORNERS TO .003-.015 RADIUS AND REMOVE ALL BURRS

EMERSON
Process Management

TITLE
TRANSFORMER ASSEMBLY

DRN RD	DATE 1/7/92	DWG NO.	REV
CHKD EM	DATE 2/11/97	CE-19492	E
ENG DLT	DATE 3/20/97	SCALE NTS	P/N SEE ORDER

SHT 1 OF 1