

Multipurpose test lamp kit



Important Instructions

Net Safety Monitoring, Inc (Net Safety) designs, manufactures and tests products to function within specific conditions. Because these products are sophisticated technical instruments, it is important that the owner and operation personnel must strictly adhere both to the information printed on the product nameplate and to all instructions provided in this manual prior to installation, operation, and maintenance.

WARNING

Installing, operating or maintaining a Net Safety Product improperly could lead to serious injury or death from explosion or exposure to dangerous substances. Comply with all information on the product, in this manual, and in any local and national codes that apply to the product. Do not allow untrained personnel to work with this product. Use Net Safety parts and work procedures specified in this manual.

Notice

The contents of this publication are presented for informational purposes only, and while every effort has been made to ensure their accuracy, they are not to be construed as warranties or guarantees, expressed or implied, regarding the products or services described herein or their use or applicability. All sales are governed by Net Safety's terms and conditions, which are available upon request. We reserve the right to modify or improve the designs or specifications of such products at any time.

Net Safety does not assume responsibility for the selection, use or maintenance of any product. Responsibility for proper selection, use and maintenance of any Net Safety products remains solely with the purchaser and end-user.

To the best of Net Safety's knowledge the information herein is complete and accurate. Net Safety makes no warranties, expressed or implied, including implied warranties of merchantability and fitness for a particular purpose with respect to this manual and, in no event, shall Net Safety be liable for any incidental, punitive, special or consequential damages including, but not limited to, loss of production, loss of profits, loss of revenue or use and costs incurred including without limitation for capital, fuel and power, and claims of third parties.

Product names used herein are for manufacturer or supplier identification only and may be trademarks/registered trademarks of these companies.

Net Safety and the Net Safety logo are registered trademarks of Net Safety Monitoring, Inc. The Emerson logo is a trademark and service mark of the Emerson Electric Company.

Copyright © 2012 by Net Safety Monitoring, Inc., Calgary, Alberta, Canada

All rights reserved. No part of this work may be reproduced or copied in any form or by any means - graphic, electronic, or mechanical without first receiving written permission of Net Safety Monitoring, Inc, Calgary, Alberta, Canada.

Warranty

- Limited Warranty.** Subject to the limitations contained in Section 10 (Limitation of Remedy and Liability) herein, Seller warrants that (a) the licensed firmware embodied in the Goods will execute the programming instructions provided by Seller; (b) that the Goods manufactured by Seller will be free from defects in materials or workmanship under normal use and care; and (c) Services will be performed by trained personnel using proper equipment and instrumentation for the particular Service provided. The foregoing warranties will apply until the expiration of the applicable warranty period. Sensors and detectors are warranted against defective parts and workmanship for 24 months from the date of purchase and other electronic assemblies for 36 months from the date of purchase. Products purchased by Seller from a third party for resale to Buyer (**Resale Products**) shall carry only the warranty extended by the original manufacturer. Buyer agrees that Seller has no liability for Resale Products beyond making a reasonable commercial effort to arrange for procurement and shipping of the Resale Products. If Buyer discovers any warranty defects and notifies Seller thereof in writing during the applicable warranty period, Seller shall, at its option, (i) correct any errors that are found by Seller in the firmware or Services; (ii) repair or replace FOB point of manufacture that portion of the Goods found by Seller to be defective; or (iii) refund the purchase price of the defective portion of the Goods/Services. All replacements or repairs necessitated by inadequate maintenance; normal wear and usage; unsuitable power sources or environmental conditions; accident; misuse; improper installation; modification; repair; use of unauthorized replacement parts; storage or handling; or any other cause not the fault of Seller, are not covered by this limited warranty and shall be replaced or repaired at Buyer's sole expense and Seller shall not be obligated to pay any costs or charges incurred by Buyer or any other party except as may be agreed upon in writing in advance by Seller. All costs of dismantling, reinstallation, freight and the time and expenses of Seller's personnel and representatives for site travel and diagnosis under this limited warranty clause shall be borne by Buyer unless accepted in writing by Seller. Goods repaired and parts replaced by Seller during the warranty period shall be in warranty for the remainder of the original warranty period or 90 days, whichever is longer. This limited warranty is the only warranty made by Seller and can be amended only in a writing signed by an authorized representative of Seller. The limited warranty herein ceases to be effective if Buyer fails to operate and use the Goods sold hereunder in a safe and reasonable manner and in accordance with any written instructions from the manufacturers. THE WARRANTIES AND REMEDIES SET FORTH ABOVE ARE EXCLUSIVE. THERE ARE NO REPRESENTATIONS OR WARRANTIES OF ANY KIND, EXPRESS OR IMPLIED, AS TO MERCHANTABILITY, FITNESS FOR PARTICULAR PURPOSE OR ANY OTHER MATTER WITH RESPECT TO ANY OF THE GOODS OR SERVICES.
- Limitation of Remedy and Liability.** SELLER SHALL NOT BE LIABLE FOR DAMAGES CAUSED BY DELAY IN PERFORMANCE. THE REMEDIES OF BUYER SET FORTH IN THE AGREEMENT ARE EXCLUSIVE. IN NO EVENT, REGARDLESS OF THE FORM OF THE CLAIM OR CAUSE OF ACTION (WHETHER BASED IN CONTRACT, INFRINGEMENT, NEGLIGENCE, STRICT LIABILITY, OTHER TORT OR OTHERWISE), SHALL SELLER'S LIABILITY TO BUYER AND/OR BUYER'S CUSTOMERS EXCEED THE PRICE TO BUYER OF THE SPECIFIC GOODS MANUFACTURED OR SERVICES PROVIDED BY SELLER GIVING RISE TO THE CLAIM OR CAUSE OF ACTION.

BUYER AGREES THAT IN NO EVENT SHALL SELLER'S LIABILITY TO BUYER AND/OR BUYER'S CUSTOMERS EXTEND TO INCLUDE INCIDENTAL, CONSEQUENTIAL OR PUNITIVE DAMAGES. THE TERM "CONSEQUENTIAL DAMAGES" SHALL INCLUDE, BUT NOT BE LIMITED TO, LOSS OF ANTICIPATED PROFITS, REVENUE OR USE AND COSTS INCURRED INCLUDING WITHOUT LIMITATION FOR CAPITAL, FUEL AND POWER, AND CLAIMS OF BUYER'S CUSTOMERS.

Contents

Section 1 : Introduction.....	1
1.1 Models covered	1
1.2 Safety instructions	1
1.3 Service support	1
1.4 Return of material.....	3
1.5 Product recycling/disposal	3
Section 2 : Installation	4
2.1 Unpacking and inspection	4
2.2 Dimensions	4
2.3 Kit contents.....	5
2.3.1 Multipurpose test lamp.....	5
2.3.2 Battery charger	7
2.3.3 Battery pack.....	8
Section 3 : Operation.....	9
3.1 Response test for IR3S flame detectors	9
3.2 Response test for UV/IRS flame detectors.....	10
3.3 Response test for UVS flame detectors	11
3.4 System Response Test	13
Section 4 : Maintenance	14
4.1 Troubleshooting.....	14
4.2 Storage	14
4.3 Spare Parts/Accessories.....	14
4.4 Battery pack replacement and positioning	16
4.5 Electronic module replacement	17
Section 5 Electrostatic sensitive device.....	18
Section 6 : Specifications	19
6.1 Electrical.....	19
6.1.1 Power consumption	19
6.1.2 Laser optical power & wavelength.....	19
6.2 Environmental.....	19
6.2.1 UV radiation	19
6.2.2 Storage temperature	19
6.2.3 Operating temperature	19
6.3 Performance.....	19
6.3.1 Maximum operating distance.....	19
6.3.2 Operating time	19
6.3.3 Battery recharging time	19
6.4 Mechanical	21
6.4.1 Ingress protection	21

6.4.2 Weight 21

Section 7 : Certifications22

7.1 North American22
7.2 ATEX (-X Version)22
7.3 IECEx (-X Version)22

Section 1 Introduction

1.1 Models covered

The multipurpose test lamp is Net Safety's latest design in test lamps and addresses the need to simulate a fire condition when testing any Net Safety flame detector series (UVS, UV/IRS and IR3S Flame Detectors). The multipurpose test lamp allows simulation in classified and hazardous locations. It consists of an electronic module and battery pack mounted inside an ATEX approved and CSA certified enclosure.

The models available are:

- TL-MP-KIT - Multipurpose test lamp kit, CSA approved
- TL-MP-KIT-X - Multipurpose test lamp kit, ATEX approved

1.2 Safety instructions

CAUTION



The test lamp generates UVC and visible radiation which can be harmful to the eyes. Proper protective eye wear should always be worn when using the multipurpose test lamp. Unprotected eyes are extremely sensitive to direct or indirect (reflected) radiation.

WARNING

Failure to follow these installation guidelines could result in death or serious injury. Ensure that only qualified personnel perform the installation.

Electrical shock could cause death or serious injury. Use extreme caution when making contact with the leads and terminals.

Do not open the test lamp enclosure when in a classified area or when an explosive atmosphere may be present.

1.3 Service support

Technical support for this product can be provided by contacting your local Emerson Process Management/Net Safety representative or by contacting the Net Safety Technical Support department at +1 866 347 3427 or safety.csc@emerson.com.

1.4 Return of material

To expedite the repair and return of this product, proper communication between the customer and the factory is important. Before returning a product for repair, call +1 866 347 3427 or email safety.csc@emerson.com for a Material Return Authorization (MRA) number.

On the return of the equipment, include the following information:

1. MRA number provided to you by Net Safety
2. Company name and contact information
3. Purchase order, from your company, authorizing repairs or request for quote
4. Ship all equipment, prepaid to:
Emerson Process Management
6021 Innovation Blvd
Shakopee, MN 55379
5. Mark all packages with as **Return for Repair** and include MRA number

Pack items to protect them from damage and use anti-static bags or aluminum-backed cardboard as protection from electrostatic damage.

All equipment must be shipped prepaid. Collect shipments will not be accepted.

1.5 Product recycling/disposal

Recycling of equipment and packaging should be taken into consideration and disposed of in accordance with local and national legislations/regulations.

Section 2 Installation

2.1 Unpacking and inspection

Carefully remove all of the components from the packaging and verify them against the enclosed packing list. Inspect all components for any obvious damage such as broken or loose parts. If you find any components missing or damaged, notify your local Net Safety representative or the factory immediately.

2.2 Dimensions

Figure 2-1 outlines the dimensions of the multipurpose test lamp.

Figure 2-1 – Multipurpose test lamp dimensions

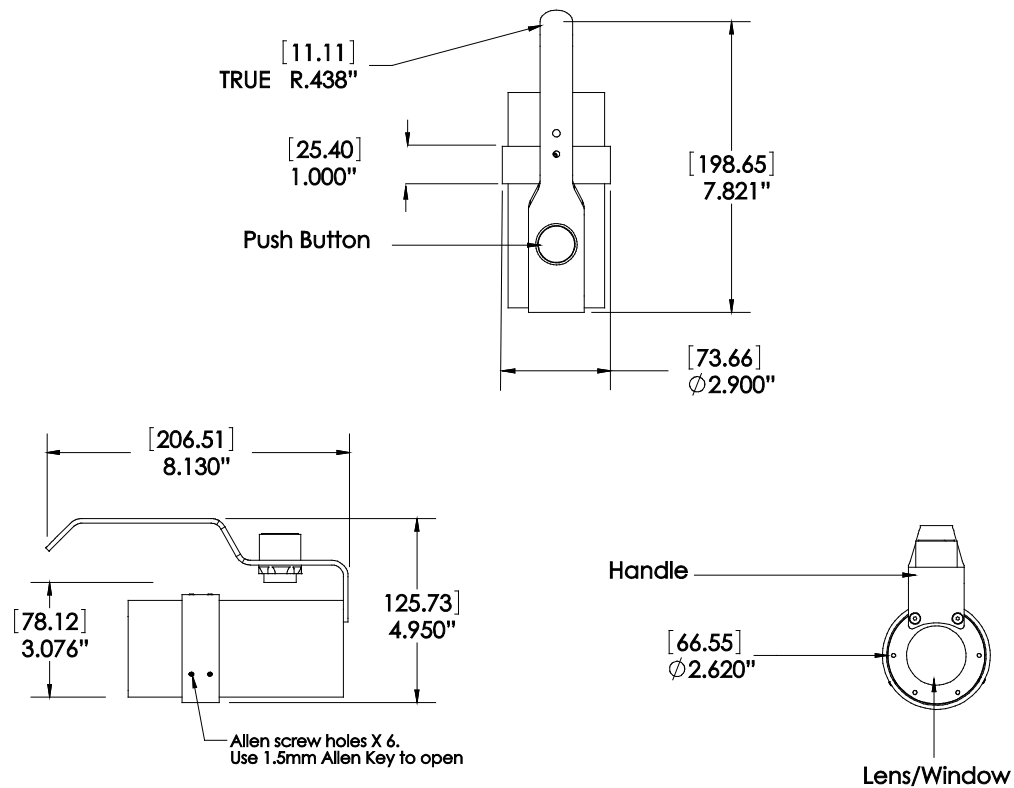

Note: ATEX Model (TL-MP-EX-X) test lamp shown

2.3 Kit contents

- Multipurpose test lamp
- Battery charger
- Accessory case
- 7.2 Volt (dc) battery pack
- Window Cleaning Kit (cloth and cleaning solution)

Note: Spare battery pack, window cleaning kit, and test lamp manual are inside accessory case.

2.3.1 Multipurpose test lamp

Figure 2-2: Test Lamp Enclosure Description

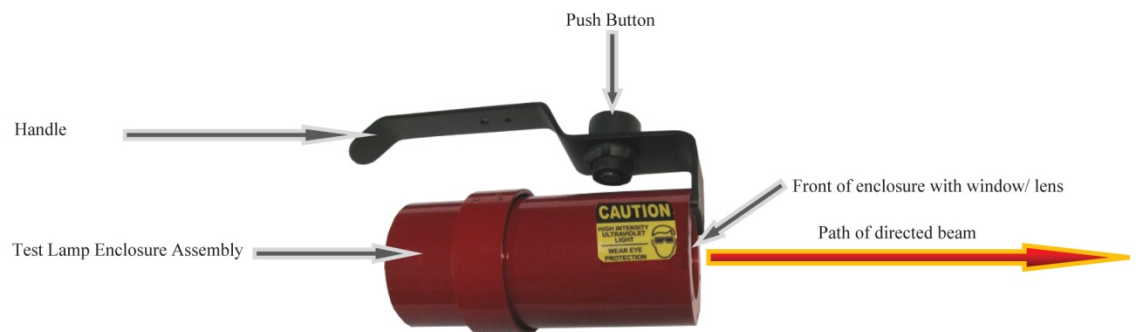

Note: ATEX model (TL-MP-EX-X) test lamp shown. CSA model does not have a locking collar.

Figure 2-3 Test lamp components

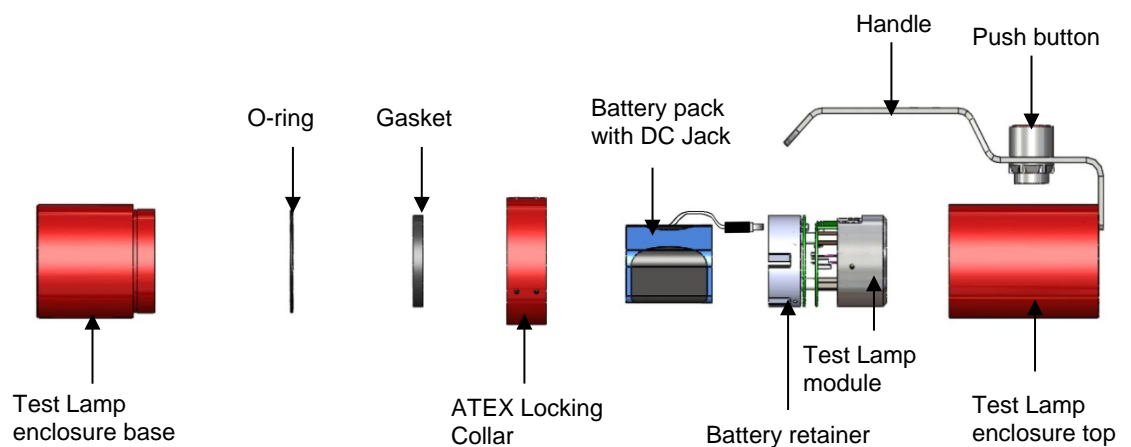

2.3.2 Battery charger

⚠ WARNING

Do not plug the charger into a DC voltage system. Disconnect battery pack from test lamp electronics module prior to charging.

Do not use the charger in a classified area.

The battery charger should always be used indoors and should be kept away from water and dust. To prevent overheating of the charger keep it away from temperatures in excess of 60 degrees Celsius. When the charger is plugged into a 100 to 240Vac outlet, the charger indicator LED will be illuminated orange within 7 seconds to indicate a connection being made to the outlet. The LED will change to red when charging of the battery pack begins. Green with intermittent orange flashes will indicate that charging is almost complete. Green LED indicates charging is complete. If a battery needs replacing or the battery pack voltage is far below normal, the LED will alternate red and green flashes to indicate error mode. When this occurs unplug the charger from the outlet then re-plug to restart charging process. If the results are the same, replace the battery pack.

The charger is provided with three (3) plug adapters. Install the plug adapter to match your local AC plug standards.

Figure 2-4: Battery Charger

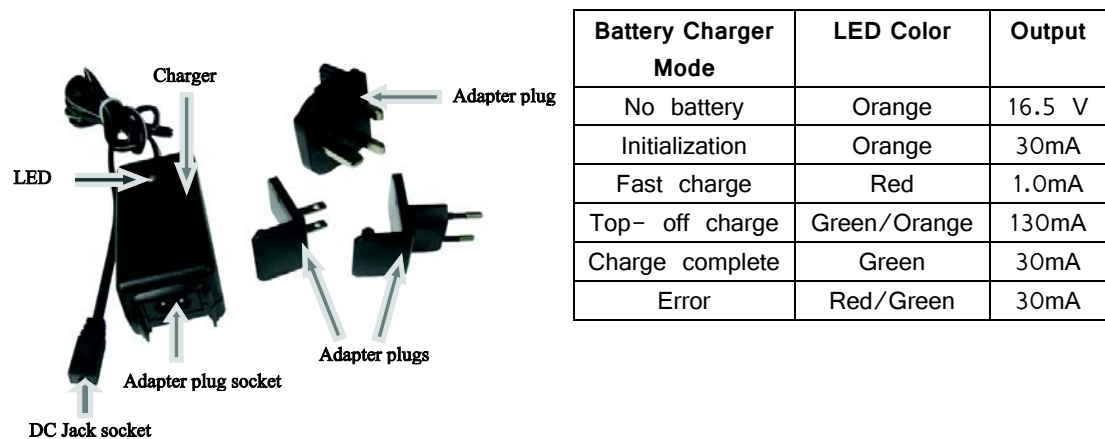

2.3.3 Battery pack

CAUTION

Dropping, damaging, or puncturing the battery pack may result in injury to personnel or cause damage to the equipment.

Important

The spare battery pack should be stored in the case to reduce the risk of any potential damage.

The required 7.2Vdc battery pack is located inside the test lamp enclosure. A spare battery pack is also included in the test lamp kit. Battery packs are rechargeable Nickel-Metal hydride (NiMH) types and they may be recharged using the charger included. To maintain the batteries in optimum working condition, the batteries should not be charged until they will no longer power the test lamp properly. The time for recharging battery pack is four (4) hours.

When batteries are no longer useable, they should be properly disposed of. Consult with local safety and environmental personnel on proper methods of disposal.

Figure 2-5 Battery pack

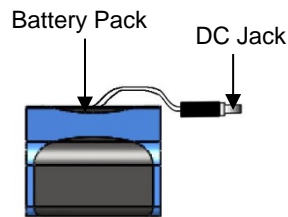

NOTICE

Only use BAT-0009 supplied by Net Safety with the test lamp.

Section 3 Operation

⚠ CAUTION

Never point the test lamp at eyes. UV light is invisible and will cause damage with repeated exposure.

When the test lamp push button is held down, ultraviolet and infrared beams will be produced. Beams should be directed at the flame detector window/lens. The location of the infrared component beam will be indicated by a red dot. During fire simulation test, the red dot should be directed at the IR target sensor of the IR3S and UV/IRS Flame Detectors. It is recommended that two persons perform the test procedure; one person should operate the test lamp, while the other observes outputs and responses at controllers and/or fire detector.

NOTICE

External systems should be placed in bypass mode to prevent system alarms and shutdowns while fire simulated tests are being performed.

Figure 3-1: Positioning Test Lamp and Flame Detector

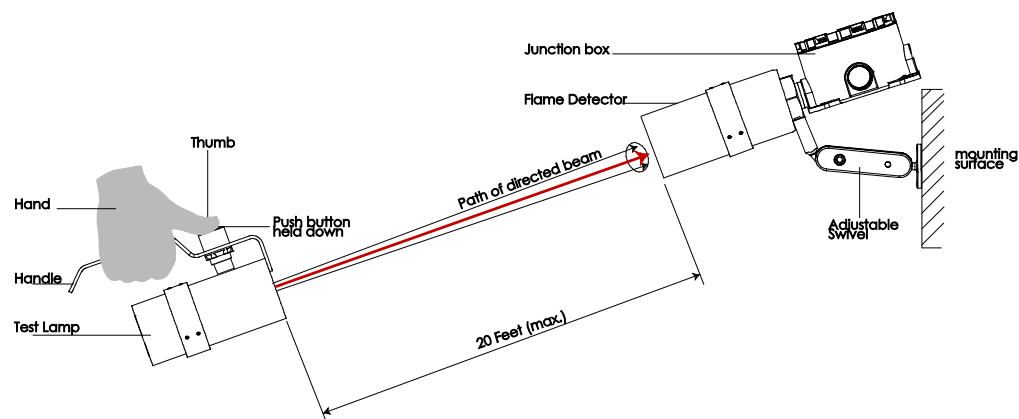

3.1 Response test for IR3S flame detectors

Follow the steps below to ensure accurate testing and fire simulation using the test lamp.

Important

When completing a fire simulation, ensure that the external system is in bypass or erroneous activation of the safety system may occur.

- Point the test lamp at the detector window, no greater than 20 feet (6.06 meters) from the detector, as shown in Figure 3-1, then press and hold the test lamp pushbutton.

- With the pushbutton held down, direct the IR laser (red dot) at the detector's target sensor as shown in Figure 3-2. The location of the target sensor will depend on the mounting orientation of the detector. After the detector time delay has elapsed, the detectors blue LED's will flash after which the red LED will be lit (solid). Refer to the detector manual (MAN-0044 or MAN-0072) for time delay settings.
- For analog and analog-HART model detectors, the signal output in alarm (20mA), can be measured using a current measuring device placed in the analog loop or across the meter test jacks inside the junction box.
- For relay model detectors, changes in fire alarm relay status may be monitored at the detector relay terminals or panel.
- For digital model detectors, digital responses may be monitored at a PLC/panel.
- After successful fire simulation, release the test lamp pushbutton and discontinue external system bypass (return external system to normal operating mode).

Figure 3-2: IR3S Flame Detector Orientations and Target Sensor Location

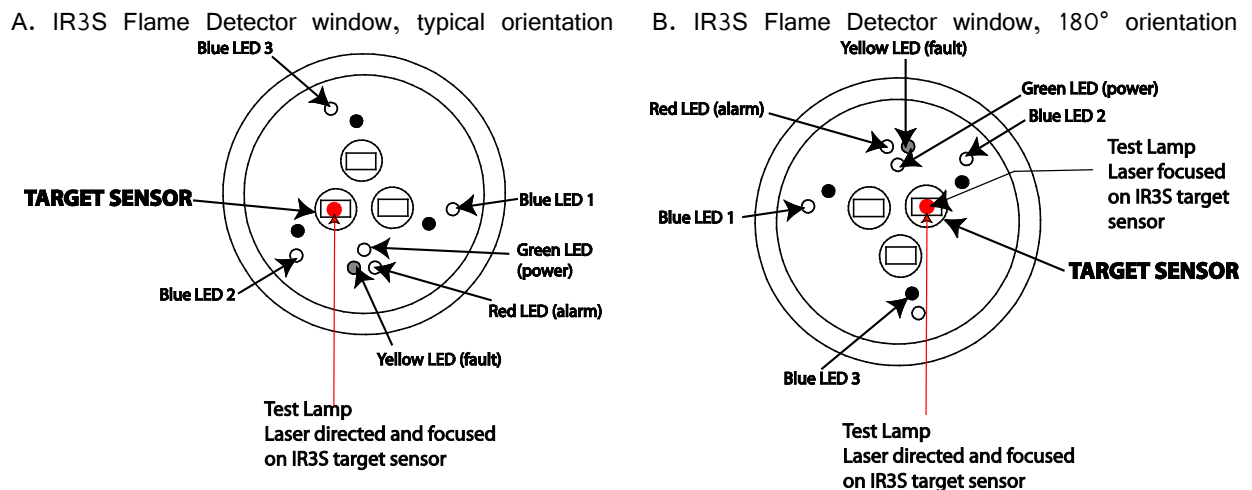

3.2 Response test for UV/IRS flame detectors

Follow the steps below to ensure accurate testing and fire simulation using the test lamp.

Important

When completing a fire simulation, ensure that the external system is in bypass or erroneous activation of the safety system may occur.

- Point the test lamp at the detector window, no greater than 20 feet (6.06 meters) from the detector, as shown in Figure 3-1, then press and hold the test lamp pushbutton.
- To simulate a fire condition, press and hold the test lamp pushbutton while directing the IR laser (red dot) at the detector's IR sensor as shown in Figure 3-3. After the detector

time delay has elapsed, the detectors red LED will flash to indicate a fire condition. Refer to the detector manual (MAN-0015 or MAN-0075) for time delay settings.

- For analog and analog-HART model detectors, the alarm signal output (20mA) can be measured using a current measuring device placed in the analog loop or across the meter test jacks inside the junction box.
- For relay model detectors, changes in fire alarm relay status may be monitored at the detector relay terminals or panel.
- After a successful fire simulation, release the test lamp pushbutton and discontinue external system bypass (return external system to normal operating mode).

Figure 3-3: UV/IRS Flame Detector Window

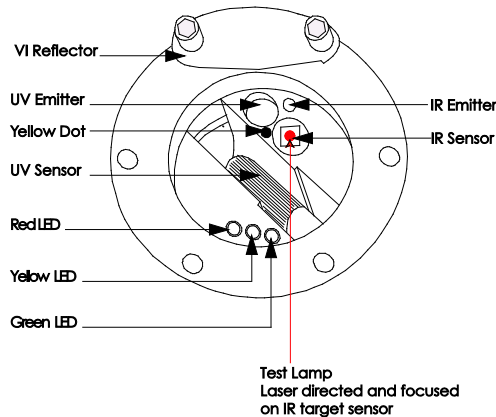

3.3 Response test for UVS flame detectors

Follow the steps below to ensure accurate testing and fire simulation using the test lamp.

Important

When completing a fire simulation, ensure that the external system is in bypass or erroneous activation of the safety system may occur.

- Point the test lamp at the detector window, no greater than 20 feet (6.06 meters) from the detector, as shown in Figure 3-1, then press and hold the test lamp pushbutton.
- To simulate a fire condition, press and hold test lamp push button beyond the duration of the detector time delay. The detector Red LED will flash after time delay duration is passed, to indicate a fire condition. See detector manual (MAN-0039 or MAN-0086) for time delay settings
- For analog and analog-Hart model detectors, the signal output (20mA) can be measured using a current measuring device placed in the analog loop or across the meter test jacks inside the junction box.

- For relay model detectors, changes in fire alarm relay status may be monitored at the detector relay terminals or panel.
- After a successful fire simulation, release the test lamp pushbutton and discontinue external system bypass (return external system to normal operating mode).

3.4 System Response Test

It is important to verify system response to a fire. System response includes relay, analog and digital output activation. This test is performed with the controller/PLC online; therefore it is important to disable all active external response devices and shut-downs. Utilize the test lamp as described above and verify that the controller outputs become active as programmed. Carefully verify analog, relay and digital output response. Remember to enable external response devices after test.

If test does not produce desired results (20 mA output current, change in the state of the alarm relay or digital output) from detector, there may be a problem with wiring or the battery pack inside the test lamp enclosure may be depleted. Check detector and system wiring, clean all optical surfaces, recharge the battery pack if necessary and repeat the test. Contact the manufacturer immediately, if the flame detector still does not respond.

NOTICE

External systems should be placed in bypass mode to prevent system alarms and shutdowns while fire simulated tests are being performed.

Section 4 Maintenance

4.1 Troubleshooting

If the flame detector does not respond to the test lamp as described in this manual, verify that the test lamp is receiving power by pointing the test lamp at a flat surface, engaging the pushbutton, and noting a red light blinking on the flat surface. If the red light is not present, conduct a visual inspection on the battery pack and wires to see if there is any damage. If damage is seen, replace the battery pack. If no physical damage is seen verify that the battery pack is charged and replace as necessary.

⚠ CAUTION

Never point the test lamp at eyes. UV light is invisible and will cause damage with repeated exposure.

If the problem remains, check all wiring to the flame detector and refer to the specific flame detector manual for troubleshooting instructions.

If the problem persists please contact our service department to try and resolve the issue over the phone as outlined in 1.3. If the issue cannot be resolved over the phone, the Net Safety representative may advise to proceed to replace either the electronic module or battery pack. For instructions on replacing the electronic module, refer to 4.4.

4.2 Storage

The test lamp and component parts should be stored in a location free from dust and moisture. The device should be stored well within the range: -40°C to $+55^{\circ}\text{C}$ (-40°F to $+140^{\circ}\text{F}$).

The test lamp uses rechargeable Nickel-Metal hydride (NiMH) batteries. When batteries are no longer used, they should be carefully disposed of. Consult with local safety and environmental personnel on methods of disposal.

4.3 Spare Parts/Accessories

Net Safety Part Number	Description
TL-MP-EX	Multipurpose test lamp - CSA approved
TL-MP-EX-X	Multipurpose test lamp - ATEX approved
TLS-MP-EMOD	TL-MP-EX electronics module
BAT-0009	7.2 V rechargeable NiMH battery pack with DC connector

TLS-MP-CHGR	90-265VAC 4-8 cell, NiCd, NiMH battery charger
WINDOW CLEANER	130ml spray bottle of anti-reflective cleaning solution

4.4 Battery pack replacement and positioning

The following procedure outlines the steps required to replace used or uncharged battery pack inside the test lamp.

⚠ WARNING

Electrical shock could cause death or serious injury. Use extreme caution when making contact with the leads and terminals.

Do not open the test lamp enclosure when in a classified area or when an explosive atmosphere may be present.

1. Remove the end cap (test lamp enclosure base) from the test lamp assembly. (Loosen the set screws on the locking collar for ATEX (TL-MP-EX-X) model test lamps using a 1.5mm Allen key and then remove end the cap). **Note:** There is no need to fully remove the locking collar.
2. Disconnect the uncharged or used battery pack from the electronics module by first unplugging the DC Jack attached to the battery pack from the DC Jack fitting at the lamp module
3. Set the uncharged or used battery pack aside. **Note:** Prior to discarding used battery packs follow all local and national procedures on proper disposal.
4. Inspect the replacement or charged battery pack and then position and fit inside the battery retainer seated in the test lamp top enclosure. See [Figure 4-1](#).
5. Connect the DC Jack on the replacement or charged battery pack to the DC Jack fitting at the test lamp module. See [Figure 4-1](#).
6. Conduct a final inspection on the battery pack wires and wire connections.
7. Replace the end cap by tightening with your hands (tighten the set screws of the locking collar if you have the ATEX model test lamp) and verify operation/power as indicated in [section 4.1](#)

Figure 4-1 Battery pack positioning

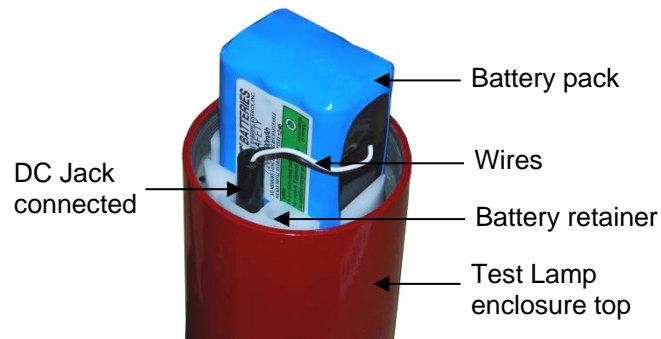

4.5 Electronic module replacement

If it is confirmed that there is a problem with the test lamp after troubleshooting checks a replacement test lamp module (TLS-MP-EMOD) may be ordered from factory and fitted on site. When replacing test lamp modules observe all safety procedures and guideline pertaining to equipment and location and refer to the test lamp module installation guide (MAN-0144) for instructions prior to fitting.

Section 5 Electrostatic sensitive device

Definition: Electrostatic discharge (ESD) is the transfer, between bodies, of an electrostatic charge caused by direct contact or induced by an electrostatic field.

The most common cause of ESD is physical contact. Touching an object can cause a discharge of electrostatic energy—ESD! If the charge is sufficient and occurs near electronic components, it can damage or destroy those components. In some cases, damage is instantaneous and an immediate malfunction occurs. However, symptoms are not always immediate—performance may be marginal or seemingly normal for an indefinite period of time, followed by a sudden failure.

To eliminate potential ESD damage, review the following guidelines:

- Handle boards by metal shields—taking care not to touch electronic components.
- Wear grounded wrist or foot straps, ESD shoes or heel grounders to dissipate unwanted static energy.
- Prior to handling boards, dispel any charge in your body or equipment.
- Ensure all components are transported and stored in static safe packaging
- When returning boards, carefully package in the original carton and static protective wrapping
- Ensure ALL personnel are educated and trained in ESD Control Procedures

In general, exercise accepted and proven precautions normally observed when handling electrostatic sensitive devices. A warning label is placed on the packaging, identifying product using electrostatic sensitive semiconductor devices.



Section 6 Specifications

6.1 Electrical

6.1.1 Power consumption

200mA @ 8Vdc, 1.6W

6.1.2 Laser optical power & wavelength

Class IIIA, 5mW CW, visible wavelengths (650nm)

6.2 Environmental

6.2.1 UV radiation

UVC (185–260 nm)

6.2.2 Storage temperature

-40°C to +55°C (-40°F to +140°F)

6.2.3 Operating temperature

-40°C to +55°C (-40°F to +140°F)

6.3 Performance

6.3.1 Maximum operating distance

20 feet (6 meters)

6.3.2 Operating time

8 hours constant use at +20°C (68°F)

6.3.3 Battery recharging time

4 hours

6.4 Mechanical

6.4.1 Ingress protection

IP66/67
Type 4X

6.4.2 Weight

Kit: 4.4lbs (2Kg)
Test lamp: 2.1lbs (1Kg)

Section 7 Certifications

7.1 North American



Class I, Division 1, Groups B, C, and D T6

Class I, Zone 1, Groups IIB+H₂ T6

Type 4X/IP66/67

-40°C \leq \leq +55°C

7.2 ATEX (-X Version)

CE 0575  II 2 G Ex d [op is] IIB+H₂ T6 Gb

-40°C \leq \leq +55°C

IP66/67

DNV10 ATEX 69831

7.3 IECEx (-X Version)

Ex d [op is] IIB+H₂ T6 Gb

-40°C \leq \leq +55°C

IP66/67

IECEx DNV 13.0005

Notes:

Notes:

Notes:

EmersonProcess.com/FlameGasDetection



AnalyticExpert.com



youtube.com/user/RosemountAnalytical



twitter.com/Rosemount_News



facebook.com/Rosemount

AMERICAS

Emerson Process Management Rosemount

6021 Innovation Blvd
Shakopee, MN 55379
U.S.A.

Toll Free +1 866 347 3427

F +1 952 949 7001

SAFETY.CSC@Emerson.com

EUROPE

Emerson Process Management AG

Neuhofstrasse 19a P.O. Box 1046

CH-6340 Baar

Switzerland

T + 41 (0) 41 768 6111

F +41 (0) 41 768 6300

SAFETY.CSC@Emerson.com

MIDDLE EAST AND AFRICA

Emerson Process Management

Emerson FZE

Jebel Ali Free Zone

Dubai, UAE

P.O. Box 17033

T +971 4 811 8100

F + 971 4 886 5465

SAFETY.CSC@Emerson.com

ASIA PACIFIC

Emerson Process Management

Asia Pacific Private Limited

1 Pandan Crescent

Singapore 128461

Republic of Singapore

T + 65 6 777 8211

F + 65 6 777 0947

SAFETY.CSC@Emerson.com

©2016 Emerson Process Management. All rights reserved.

The Emerson logo is a trademark and service mark of Emerson Electric Co. Rosemount is a mark of one of the Emerson Process Management family of companies. All other marks are property of their respective owners.

The contents of this publication are presented for information purposes only, and, while effort has been made to ensure their accuracy, they are not to be construed as warranties or guarantees, express or implied, regarding the products or services described herein or their use or applicability. All sales are governed by our terms and conditions, which are available on request. We reserve the right to modify or improve the designs or specifications of our products at any time without notice.