

Rosemount™ 5300 Level Transmitter

High Level Supervision

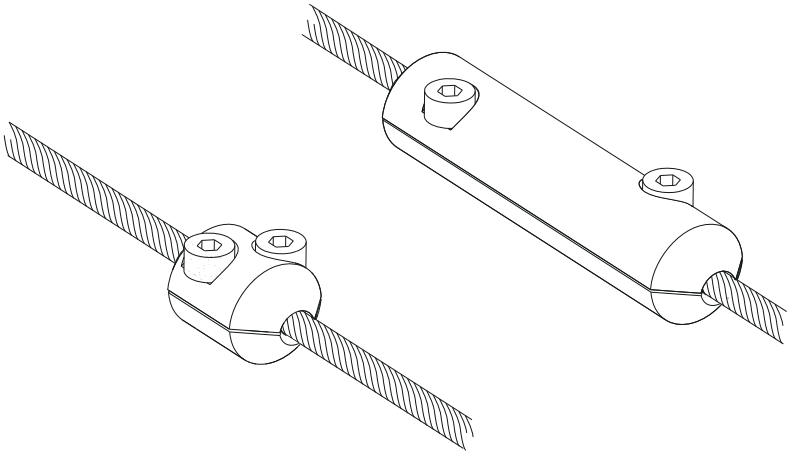

HART
COMMUNICATION PROTOCOL

Contents

Safety messages.....	3
Introduction.....	4
Installation.....	7
Configure the High Level Supervision function.....	14
Perform High Level Supervision test.....	22
Perform proof test for SIS applications.....	24
Preventive maintenance.....	33
Service and troubleshooting.....	35
Product Data Sheet for High Level Supervision.....	38

1 Safety messages

⚠ WARNING

Failure to follow safe installation and servicing guidelines could result in death or serious injury.

- Only qualified personnel should install the equipment.
- Use the equipment only as specified in this guide and the Reference Manual. Refer to the Rosemount 5300 Level Transmitter [Reference Manual](#) for more instruction.

Explosions could result in death or serious injury.

- Installation of device in an explosive environment must be in accordance with appropriate local, national, and international standards, codes, and practices.
- Ensure device is installed in accordance with intrinsically safe or non-incendive field practices.

Electrical shock could cause death or serious injury.

- Avoid contact with the leads and terminals. High voltage that may be present on leads can cause electrical shock.
- Make sure the mains power to the transmitter is off and the lines to any other external power source are disconnected or not powered while wiring the transmitter.

Process leaks could result in death or serious injury.

- Handle the transmitter carefully.
 - If the process seal is damaged, gas could escape from the tank when removing the transmitter head from the probe.
-

2 Introduction

The High Level Supervision (HLS) function in the Rosemount 5300 Level Transmitter is used to monitor a high level alarm limit. A reference reflector is mounted on the probe at the position of the alarm limit. The HLS function is also included in several Proof tests for Safety Instrumented System (SIS) applications.

The test function

A test function is available where the device will output the level corresponding to the reference reflector echo. This test proves that the device is properly monitoring the reference reflector echo and can be used to test the high level alarm in the host system.

The test function is useful to verify several conditions:

- Output from device corresponds to alarm limit configured in the host system.
- Primary Variable, Upper Range Value, and Lower Range Value have been properly configured in the device by performing a two point verification of the output. The test function enables test of the second point (reference reflector) without raising level.
- Reference reflector is found at the calibrated distance
 - Device is capable of performing a successful measurement.
 - High Level Supervision function has been activated and properly calibrated.

(The High Level Supervision Test function supplements the Loop Test function. You may still use a Loop Test to set a fixed analog out current and check loop between device and host system.)

Proof tests for Safety Instrumented System (SIS) applications

Regular proof testing is an essential requirement for SIS in liquid level measurement applications, as it ensures that they are operating to the necessary safety integrity level. The High Level Supervision test function can be used for proof testing; see [Perform proof test for SIS applications](#).

For additional SIS and proof test information refer to the Rosemount 5300 [Reference Manual](#) section: Safety Instrumented Systems.)

Continuous monitoring

In addition, the device continuously monitors the echo corresponding to the reference reflector and evaluates its position. The echo will be affected when the product surface level is above the alarm limit.

This information is used by the device to determine if the product surface level is at or above the high level alarm limit. The device will output the level

corresponding to the surface level, but if the reference reflector echo is not found and no valid surface echo is detected at or above the reference reflector, then the device will alert this condition.

2.1 High Level Supervision kit

Figure 2-1: Kit for Model Code HL1 and HL2

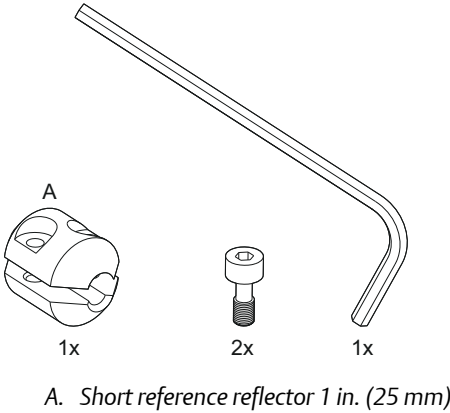

Figure 2-2: Kit for model code HL3

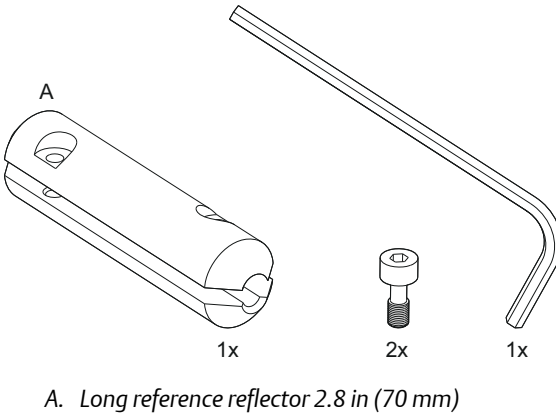

Table 2-1: High Level Supervision Kits

Article number	Description
05300-7200-0001	Kit for model code HL1 and HL2
05300-7200-0002	Kit for model code HL3

2.2 Required equipment



Measuring tape



Marker pen



Standard tools, e.g. screwdriver, wrench, pliers



Rosemount Radar Master

- Version 3.G0 or later



Rosemount 5300 firmware

- Version 2.H0 or later
- High Level Supervision software option enabled

3 Installation

Note

Make sure to follow the instructions carefully for successful installation.

3.1 Verify reference reflector in kit matches application

Different reference reflectors are used depending on the installation environment.

Procedure

Select reference reflector according to [Table 3-1](#).

Table 3-1: Application Categories

Device mounting type	Reference reflector type	Model code
3-in. to 8-in. pipe/chamber (inner diameter)	Short 1 in. (25 mm) 	HL1, HL2
10-in. pipe/chamber or bigger (inner diameter) or Open tank (tank without pipe)	Long 2.8 in. (70 mm) 	HL3

Figure 3-1: Mounting Types



- A. Pipe/chamber
- B. Open tank
- C. Inner diameter

3.2 Mounting considerations for the reference reflector

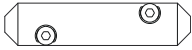
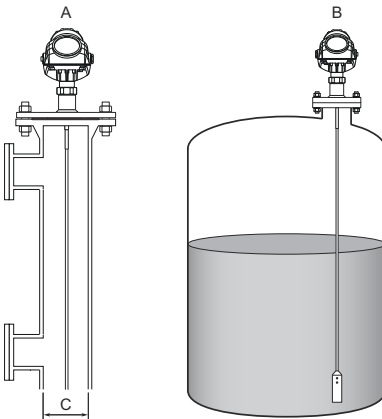
Figure 3-2: Mounting Range

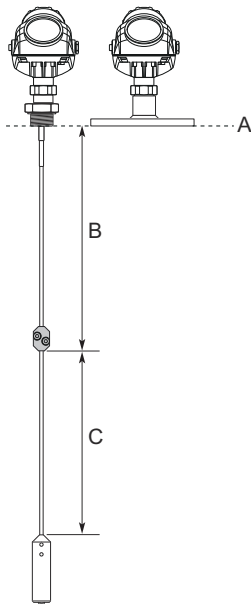

- A. Upper Reference Point
 - B. 20 in. (500 mm) to 157.5 in. (4000 mm)
 - C. Minimum 20 in. (500 mm)
-

Figure 3-3: Interfering Objects

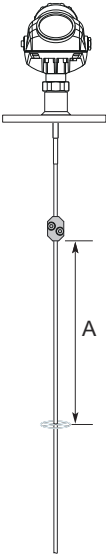

A. Minimum 20 in. (500 mm)

Figure 3-4: Process Inlets

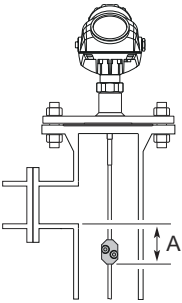

A. Minimum 2 in. (50 mm)

Figure 3-5: Nozzle Installation

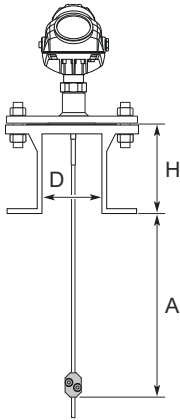

A. Minimum 20 in. (500 mm)

Table 3-2: Nozzle Considerations

Description	Recommendation
Minimum Nozzle Diameter (D):	3 in. (75 mm)
Recommended maximum Nozzle Diameter (D):	8 in. (200 mm)
Recommended maximum Nozzle Height (H):	4 in. (100 mm) + Nozzle Diameter (D) (e.g. max 10 in. for a 6 in. nozzle)

Figure 3-6: Nozzle Extended into Tank

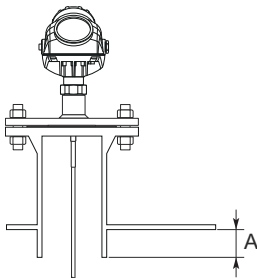

A. Maximum 1 in. (25 mm)

3.3 Calculate where to position the reference reflector

Procedure

1. Determine the distance X, High Level Alarm Limit.
(Distance from Upper Reference Point to High Level Alarm Limit.)

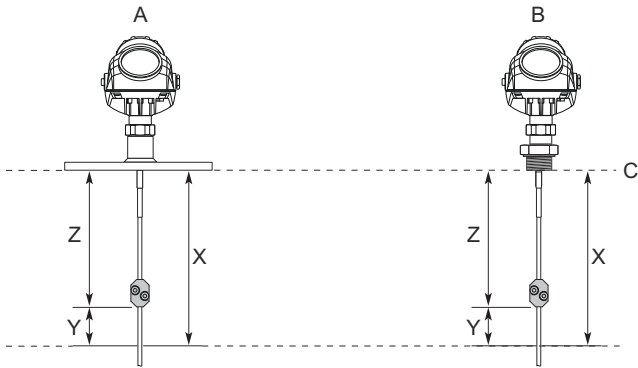

X, High Level Alarm Limit:

Figure 3-7: Positioning the Reference Reflector



- A. Flanged connection
- B. Threaded connection
- C. Upper Reference Point

Table 3-3: Distance to Subtract

Reference reflector type	Y, distance to subtract
Short 	4.3 in. (110 mm)
Long 	2.4 in. (60 mm)

2. Calculate distance Z, Reference Reflector Physical Distance.
(Subtract distance Y according to [Table 3-3](#) from distance X High Level Alarm Limit.)

Z, Reference Reflector Physical Distance:
 $Z = X - Y =$

3.4 Mount the reference reflector

Procedure

1. Place the device with the probe on the ground or a work bench.
2. Mark where to place the reference reflector.

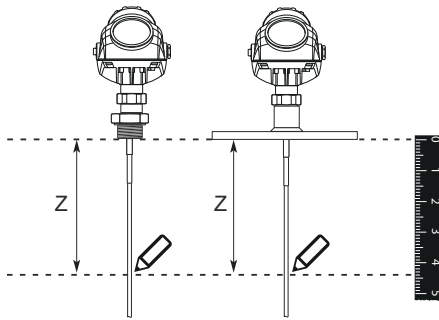

3. Place the reference reflector on the probe.

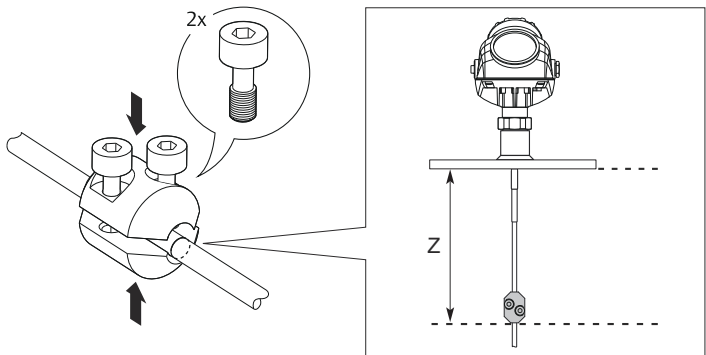

4. Fasten the screws.
 - a) Tighten both screws loosely first.
 - b) Then tighten both screws to 2 Nm, using the hex key.

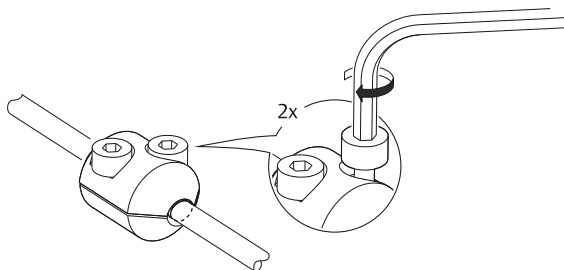

5. Mount the device on the tank.

Note

It is recommended to continue with configuration of High Level Supervision before tightening the bolts to avoid re-work.

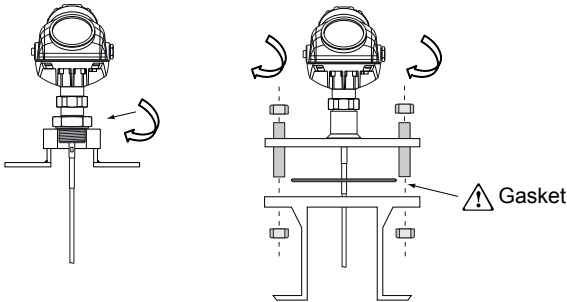

For further instruction, see the Rosemount 5300 [Reference Manual](#).

3.5 Wiring diagram

Figure 3-8: Wiring Diagram for 4-20 mA/HART®

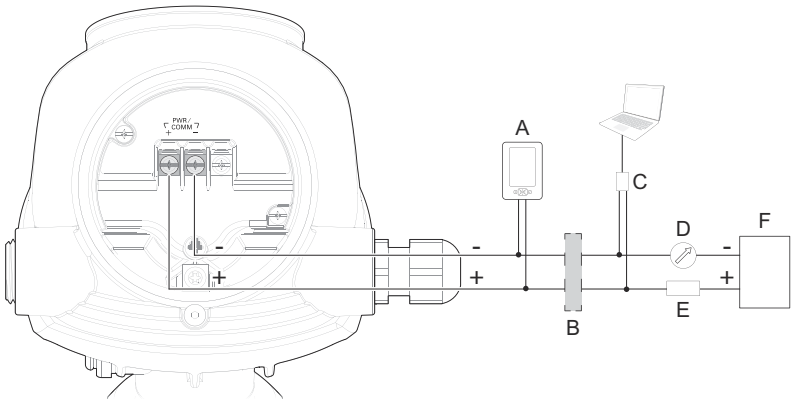

- A. Handheld communicator
- B. Approved IS barrier (for Intrinsically Safe installations only)
- C. HART modem
- D. Current meter
- E. Load resistance ($\geq 250 \Omega$)
- F. Power supply

Note

Rosemount 5300 Level Transmitters with flameproof/explosion-proof output have a built-in barrier; no external barrier needed.

4 Configure the High Level Supervision function

Prerequisites

Rosemount Radar Master must be used to configure the High Level Supervision function.

Procedure

1. Connect to device.
 - a) Start Rosemount Radar Master.
 - b) Connect to device (see [Figure 3-8](#)).

For further instructions, see the Rosemount 5300 [Reference Manual](#).

2. Before calibrating the High Level Supervision, perform the basic device configuration.
 - a) Select **Setup** → **Guided Setup**.
 - b) Click the **Run Wizard for guided setup** button, and follow the instructions.
3. Prepare for calibration of High Level Supervision.
 - a) Make sure that the product level is at least 20 in. (500 mm) below the lower side of the reference reflector (or that the vessel is empty).

Figure 4-1: Product Level

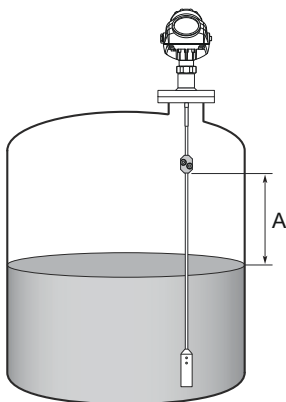

A. Minimum 20 in. (500 mm)

Note

The device may lock on the reference reflector and report this as surface level before the function has been calibrated.

- b) Make sure the ambient temperature is within applicable range during calibration:

Device mounting type	Ambient temperature
3-in. to 6-in. pipe/chamber (inner diameter)	32 °F to 104 °F (0 °C to 40 °C)
8-in. pipe/chamber or bigger (inner diameter) or Open tank (tank without pipe)	-4 °F to 122 °F (-20 °C to 50 °C)

4. Calibrate High Level Supervision.

- a) Select **Setup** → **Advanced**, and then click the **Level Supervision** tab.

Note

If the Level Supervision tab is missing, it indicates the device does not support High Level Supervision. You may upgrade device to enable the functionality. Contact your local Emerson representative for more information.

- b) Select the **Use High Level Supervision** checkbox and click **Store**.
- c) Click **Calibrate High Level Supervision** to let transmitter identify the reference reflector.
- d) Select the Search from top of the tank option and click **Calibrate**.
The distance to the reference reflector echo is reported by the device when calibration succeeds.

Calibrated Reflector Echo Distance
(reported by device):

Note

The reference reflector echo appears slightly below the physical reference reflector. See [Figure 4-2](#) for more information.

Need help?

See section [Service and troubleshooting](#) if calibration fails.

5. Verify Calibrated Reflector Echo Distance.

Compare the Reference Reflector Physical Distance (Z) with the Calibrated Reflector Echo Distance reported by device.

The calibration is correct if the reference reflector echo appears 0.4 in. (10 mm) to 3.5 in. (90 mm) below the lower side of the physical reflector.

Figure 4-2: Reference Reflector Echo

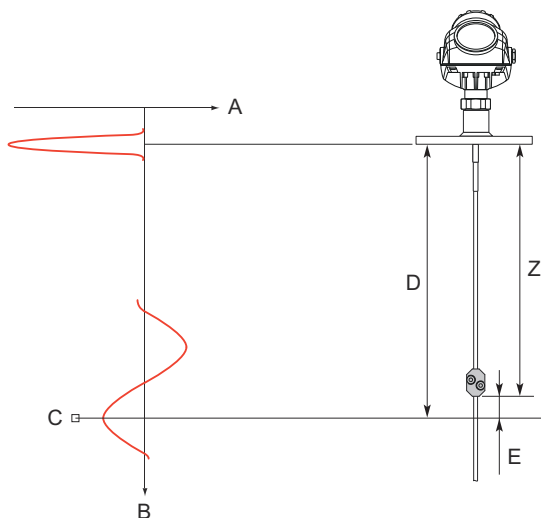

- A. Amplitude
- B. Distance
- C. Reference Reflector Echo
- D. Calibrated Reflector Echo Distance
- E. 0.4 in. (10 mm) to 3.5 in. (90 mm) range for correct calibration

Need help?

If the Calibrated Reflector Echo Distance is incorrect, then execute the Calibrate method again. You may enter an approximate distance to the reference reflector. For further troubleshooting, see section [Service and troubleshooting](#).

6. Verify High Level Alarm Limit (X) compared to Calibrated Reflector Echo Distance.

Compare the High Level Alarm Limit in your host system with the Calibrated Reflector Echo Distance reported by device.

The High Level Alarm Limit in the host system should be between 1.2 in. (30 mm) to 2.4 in. (60 mm) below the Calibrated Reflector Echo Distance.

Figure 4-3: High Level Alarm Limit

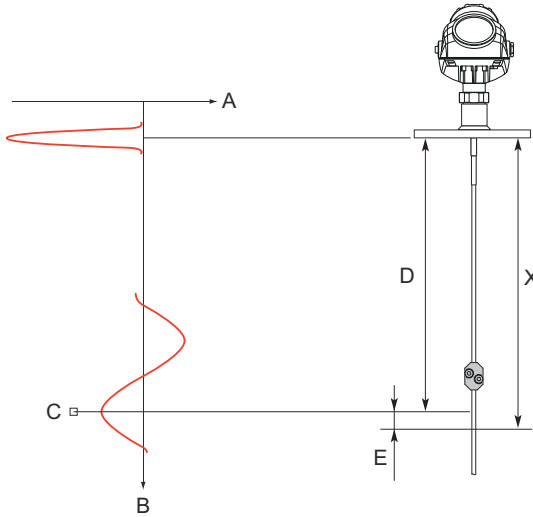

- A. Amplitude
- B. Distance
- C. Reference Reflector Echo
- D. Calibrated Reflector Echo Distance
- E. 0.4 in. (10 mm) to 3.5 in. (90 mm) range for correct calibration

Need help?

If the High Level Alarm Limit is out of range, then reposition the reference reflector and calibrate High Level Supervision again.

7. Verify Calibrated Reflector Echo Amplitude.
 - a) In the **Reflector Measurement Details** section, review Calibrated Reflector Echo Amplitude.
 - b) Verify that Calibrated Reflector Echo Amplitude is within applicable range depending on application:

Device mounting type	Calibrated Reflector Echo Amplitude
3-in. to 6-in. pipe/chamber (inner diameter)	Between -700 mV and -2200 mV
8-in. pipe/chamber or bigger (inner diameter) or Open tank (tank without pipe)	Between -700 mV and -1800 mV

Need help?

See section [Service and troubleshooting](#) if echo amplitude is out of range.

8. Verify that surface threshold is correct for the application.
 - a) Select **Setup** → **Echo Curve** to read the echo curve.
 - b) Verify that Surface Threshold is configured correctly in interval around reference reflector for the application:

Device mounting type	Surface Threshold
3-in. to 6-in. pipe/chamber (inner diameter)	1500 mV
8-in. pipe/chamber or bigger (inner diameter) or Open tank (tank without pipe)	900 mV

Figure 4-4: Surface Threshold

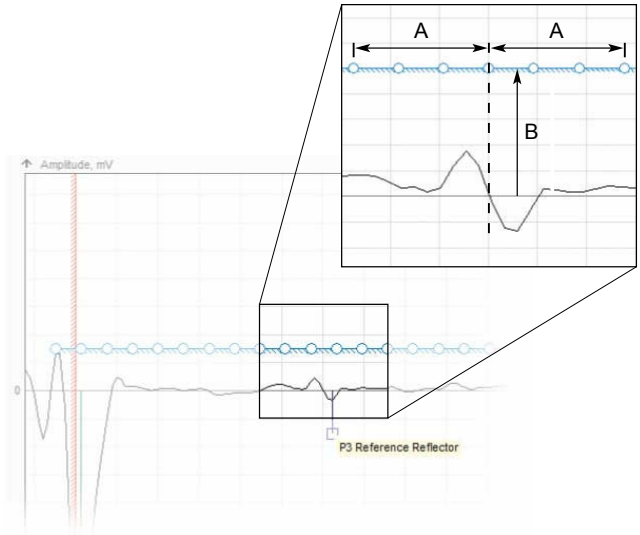

- A. 10 in. (250 mm)
- B. 900 mV or 1500 mV

Need help?

See section [Set surface threshold manually around reference reflector](#) if threshold deviates from required value.

9. Continue with configuration of device using Guided Setup.
 - a) Select **Setup** → **Guided Setup**.
 - b) Click the **Device specific setup** button, and follow the instructions.
 - c) Click the **Restart the Device** button, and follow the instructions.
 - d) Click the **Archive Device** button, and follow the instructions.

Note

Do not use Verify Level in Guided Setup to adjust level measurement. Modify the Tank Height parameter if level measurement needs to be adjusted.

10. Verify High Level Supervision is operational.

Perform a High Level Supervision Test following the procedure in section [Perform High Level Supervision test](#).

11. Make sure process connection on tank is securely closed.

For further instruction, see the Rosemount 5300 [Reference Manual](#).

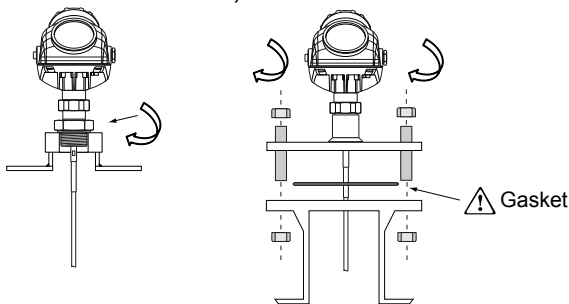

4.1 Configuration parameters

4.1.1 Alarm behavior

This parameter defines the measurement output to use if the reference reflector cannot be found as expected. A digital alert is always set in case of a High Level Supervision alarm condition (independent of this setting).

Table 4-1: Alarm Behavior

Alarm Behavior	Description
Tank is Full (default)	Device output will correspond to full tank (Distance = 0).
Alarm	Analog output goes to configured alarm mode (high or low).
No Action	Device continues to output surface level from the normal measurement logic even if there is a mismatch.
<p>⚠ WARNING</p> <p>When using this option the alarm condition will not be detectable on the 4-20 mA loop. Make sure the digital alert is polled and used in the host system or use the test function more often to detect this condition.</p>	

Related information

[High Level Supervision Alarming](#)

4.1.2 Test Mode Timeout

Defines how long the device will wait until it automatically exits the test mode.

5 Perform High Level Supervision test

5.1 Perform High Level Supervision test using Rosemount Radar Master

Prerequisites

The product surface level should be at least 20 in. (500 mm) below the reference reflector during the test.

The product surface level cannot be within 6 in. (150 mm) of the reference reflector. The device will exit the test mode if the level rises within this area during test, and instead output the current level measurement reading. It will not enter the test mode if the surface already is within this distance.

⚠ WARNING

During the test the device will not output measurement values corresponding to the product surface level. Make sure systems and people relying on measurement values from the device are made aware of the changed conditions.

Procedure

1. Start Test Mode.
 - a) Select **Setup** → **Advanced**.
 - b) Click the **Level Supervision** tab.
 - c) Click **Start/Stop Test Mode**.

Device will now output the level corresponding to the position of the reference reflector echo. The text `HLS Test OK` will appear on the device display if test is successful.

2. Verify that the output from the device corresponds to the alarm limit in the host system.
3. End test mode by clicking **Start/Stop Test Mode** again.
(The device will automatically exit the test mode after 30 minutes [default]).

5.2 Perform High Level Supervision test using AMS Device Manager and handheld communicator

Prerequisites

The product surface level should be at least 20 in. (500 mm) below the reference reflector during the test.

The product surface level cannot be within 6 in. (150 mm) of the reference reflector. The device will exit the test mode if the level rises within this area during test, and instead output the current level measurement reading. It will not enter the test mode if the surface already is within this distance.

⚠ WARNING

During the test the device will not output measurement values corresponding to the product surface level. Make sure systems and people relying on measurement values from the device are made aware of the changed conditions.

Procedure

1. Start Test Mode.
 - a) Select **Configure** → **Alert Setup** → **Level Supervision**.
 - b) Click **Start/Stop Test Mode**.

Device will now output the level corresponding to the position of the reference reflector echo. The text `HLS Test OK` will appear on the device display if test is successful.

2. Verify that the output from the device corresponds to the alarm limit in the host system.
3. End test mode by clicking **Start/Stop Test Mode** again.
(The device will automatically exit the test mode after 30 minutes [default]).

6 Perform proof test for SIS applications

6.1 Overview

The following proof tests are recommended. If an error is found in the safety function, the measuring system must be switched out of service and the process held in a safe state by means of other measures.

Note

For a valid result, always perform the proof test on the product that will be stored in the tank while the device is in operation.

Note

Before every test, make sure you are connected to the correct transmitter by verifying QT/QS in the model code on the label and your software version. Also verify that the serial number on the label matches the one in your configuration tool. Make sure to enable write protection as soon as you are finished.

Tools required

- HART host/communicator
- Current meter

6.2 Prepare for proof-testing

6.2.1 Prepare for proof-testing using Rosemount Radar Master

Note that prior to these tests, inspect the echo curve to ensure that no disturbing echoes affecting the measurement performance are present.

Procedure

Select **Setup** → **Echo Curve**.

6.2.2 Prepare for proof-testing using AMS Device Manager and handheld communicator

Note that prior to these tests, inspect the echo curve to ensure that no disturbing echoes affecting the measurement performance are present.

Procedure

Select **Service Tools** → **Echo Tuning** → **Echo Curve**.

6.3 Suggested comprehensive proof-test using reference reflector (High Level Supervision)

6.3.1 Suggested comprehensive proof-test using reference reflector (High Level Supervision) with Rosemount Radar Master

The suggested proof-test described below will detect 94 percent of possible DU failures in the Rosemount 5300 Level Transmitters.

Procedure

1. Bypass the safety function and take appropriate action to avoid a false trip.
2. Disable write protection in device (if enabled).
 - a) Select **Tools** → **Lock/Unlock Configuration Area**.
 - b) Enter password to unlock.
3. Using Loop Test, enter current value (mA) representing high alarm current. Verify that analog output current is correct using the reference meter.
 - a) Select **Setup** → **Output** → **Analog Out 1** and click **Loop test**.
 - b) Enter current value representing high alarm current.
 - c) Click **Start** to output current.
 - d) Verify that analog output current is correct.
 - e) Click **Stop** to end loop test.
4. Using Loop Test, enter current value (mA) representing low alarm current. Verify that analog output current is correct using the reference meter.
 - a) Select **Setup** → **Output** → **Analog Out 1** and click **Loop test**.
 - b) Enter current value representing low alarm current.
 - c) Click **Start** to output current.
 - d) Verify that analog output current is correct.
 - e) Click **Stop** to end loop test.
5. Enable write protection.
 - a) Select **Tools** → **Lock/Unlock Configuration Area**.
 - b) Enter password to lock.
6. Perform High Level Supervision test.

- a) Select **Setup** → **Advanced**.
 - b) Select the **Level Supervision** tab.
 - c) Select **Start/Stop Test Mode**.
 - d) Verify that the output from the device corresponds to the alarm limit in the host system.
 - e) End test mode by clicking **Start/Stop Test Mode**.
The device will automatically exit the test mode after 30 minutes (default).
7. Inspect the transmitter for any leaks, visible damage, or contamination.
 8. Remove the bypass and otherwise restore normal operation.

6.3.2 Suggested comprehensive proof-test using reference reflector (High Level Supervision) with AMS Device Manager and handheld communicator

The suggested proof-test described below will detect 94 percent of possible DU failures in the Rosemount 5300 Level Transmitters.

Procedure

1. Bypass the safety function and take appropriate action to avoid a false trip.
2. Disable write protection in device (if enabled).
 - a) Select **Configure** → **Manual Setup** → **Device Setup** → **Security**.
 - b) Click **Write Protect** and follow the instructions.
3. Using Loop Test, enter current value (mA) representing high alarm current. Verify that analog output current is correct using the reference meter.
 - a) Select **Configure** → **Manual Setup** → **Device Setup** → **Analog Output**.
 - b) Click **Loop Test** and select **Other**.
 - c) Enter current value representing high alarm current.
 - d) Verify that analog output current is correct.
 - e) Click **Abort** to end loop test.

4. Using Loop Test, enter current value (mA) representing low alarm current. Verify that analog output current is correct using the reference meter.
 - a) Select **Configure** → **Manual Setup** → **Device Setup** → **Analog Output**.
 - b) Click **Loop Test** and select **Other**.
 - c) Enter current value representing low alarm current.
 - d) Verify that analog output current is correct.
 - e) Click **Abort** to end loop test.
5. Enable write protection.
 - a) Select **Configure** → **Manual Setup** → **Device Setup** → **Security**.
 - b) Click **Write Protect** and follow the instructions.
6. Perform High Level Supervision test.
 - a) Select **Configure** → **Alert Setup** → **Level Supervision**.
 - b) Select **Start/Stop Test Mode**.
 - c) Verify that the output from the device corresponds to the alarm limit in the host system.
 - d) End test mode by clicking **Start/Stop Test Mode**.
The device will automatically exit the test mode after 30 minutes (default).
7. Inspect the transmitter for any leaks, visible damage, or contamination.
8. Remove the bypass and otherwise restore normal operation.

6.4 Suggested comprehensive, fully remote proof-test using reference reflector (High Level Supervision)

6.4.1 Suggested comprehensive, fully remote proof-test using reference reflector (High Level Supervision) with Rosemount Radar Master

The suggested proof-test described below will detect 86 percent of possible DU failures in the Rosemount 5300 Level Transmitters.

Procedure

1. Bypass the safety function and take appropriate action to avoid a false trip.
2. Disable write protection in device (if enabled).

- a) Select **Tools** → **Lock/Unlock Configuration Area**.
 - b) Enter password to unlock.
3. Using Loop Test, enter current value (mA) representing high alarm current. Verify that analog output current is correct using the reference meter.
 - a) Select **Setup** → **Output** → **Analog Out 1** and click **Loop test**.
 - b) Enter current value representing high alarm current.
 - c) Click **Start** to output current.
 - d) Verify that analog output current is correct.
 - e) Click **Stop** to end loop test.
 4. Using Loop Test, enter current value (mA) representing low alarm current. Verify that analog output current is correct using the reference meter.
 - a) Select **Setup** → **Output** → **Analog Out 1** and click **Loop test**.
 - b) Enter current value representing low alarm current.
 - c) Click **Start** to output current.
 - d) Verify that analog output current is correct.
 - e) Click **Stop** to end loop test.
 5. Enable write protection.
 - a) Select **Tools** → **Lock/Unlock Configuration Area**.
 - b) Enter password to lock.
 6. Perform High Level Supervision test.
 - a) Select **Setup** → **Advanced**.
 - b) Select the **Level Supervision** tab.
 - c) Select **Start/Stop Test Mode**.
 - d) Verify that the output from the device corresponds to the alarm limit in the host system.
 - e) End test mode by clicking **Start/Stop Test Mode**.
The device will automatically exit the test mode after 30 minutes [default].
 7. Remove the bypass and otherwise restore normal operation.

6.4.2 Suggested comprehensive, fully remote proof-test using reference reflector (High Level Supervision) with AMS Device Manager and handheld communicator

The suggested proof-test described below will detect 86 percent of possible DU failures in the Rosemount 5300 Level Transmitters.

Procedure

1. Bypass the safety function and take appropriate action to avoid a false trip.
2. Disable write protection in device (if enabled).
 - a) Select **Configure** → **Manual Setup** → **Device Setup** → **Security**.
 - b) Click **Write Protect** and follow the instructions.
3. Using Loop Test, enter current value (mA) representing high alarm current. Verify that analog output current is correct using the reference meter.
 - a) Select **Configure** → **Manual Setup** → **Device Setup** → **Analog Output**.
 - b) Click **Loop Test** and select **Other**.
 - c) Enter current value representing high alarm current.
 - d) Verify that analog output current is correct.
 - e) Click **Abort** to end loop test.
4. Using Loop Test, enter current value (mA) representing low alarm current. Verify that analog output current is correct using the reference meter.
 - a) Select **Configure** → **Manual Setup** → **Device Setup** → **Analog Output**.
 - b) Click **Loop Test** and select **Other**.
 - c) Enter current value representing low alarm current.
 - d) Verify that analog output current is correct.
 - e) Click **Abort** to end loop test.
5. Enable write protection.
 - a) Select **Configure** → **Manual Setup** → **Device Setup** → **Security**.

- b) Click **Write Protect** and follow the instructions.
6. Perform High Level Supervision test.
 - a) Select **Configure** → **Alert Setup** → **Level Supervision**.
 - b) Select **Start/Stop Test Mode**.
 - c) Verify that the output from the device corresponds to the alarm limit in the host system.
 - d) End test mode by clicking **Start/Stop Test Mode**.
The device will automatically exit the test mode after 30 minutes [default].
7. Remove the bypass and otherwise restore normal operation.

6.5 Suggested proof-test using reference reflector (High Level Supervision)

6.5.1 Suggested proof-test using reference reflector (High Level Supervision) with Rosemount Radar Master

The suggested proof-test described below will detect 82 percent of possible DU failures in the Rosemount 5300 Level Transmitters.

Procedure

1. Bypass the safety function and take appropriate action to avoid a false trip.
2. Perform High Level Supervision test.
 - a) Select **Setup** → **Advanced**.
 - b) Select the **Level Supervision** tab.
 - c) Select **Start/Stop Test Mode**.
 - d) Verify that the output from the device corresponds to the alarm limit in the host system.
 - e) End test mode by clicking **Start/Stop Test Mode**.
The device will automatically exit the test mode after 30 minutes [default].
3. Inspect the transmitter for any leaks, visible damage, or contamination.
4. Remove the bypass and otherwise restore normal operation.

6.5.2 Suggested proof-test using reference reflector (High Level Supervision) with AMS Device Manager and handheld communicator

The suggested proof-test described below will detect 82 percent of possible DU failures in the Rosemount 5300 Level Transmitters.

Procedure

1. Bypass the safety function and take appropriate action to avoid a false trip.
2. Perform High Level Supervision test.
 - a) Select **Configure** → **Alert Setup** → **Level Supervision**.
 - b) Select **Start/Stop Test Mode**.
 - c) Verify that the output from the device corresponds to the alarm limit in the host system.
 - d) End test mode by clicking **Start/Stop Test Mode**.
The device will automatically exit the test mode after 30 minutes [default].
3. Inspect the transmitter for any leaks, visible damage, or contamination.
4. Remove the bypass and otherwise restore normal operation.

6.6 Suggested fully remote proof-test using reference reflector (High Level Supervision)

6.6.1 Suggested fully remote proof-test using reference reflector (High Level Supervision) with Rosemount Radar Master

The suggested proof-test described below will detect 74 percent of possible DU failures in the Rosemount 5300 Level Transmitters.

Procedure

1. Bypass the safety function and take appropriate action to avoid a false trip.
2. Perform High Level Supervision test.
 - a) Select **Setup** → **Advanced**.
 - b) Select the **Level Supervision** tab.
 - c) Select **Start/Stop Test Mode**.
 - d) Verify that the output from the device corresponds to the alarm limit in the host system.
 - e) End test mode by clicking **Start/Stop Test Mode**.

The device will automatically exit the test mode after 30 minutes [default].

3. Remove the bypass and otherwise restore normal operation.

6.6.2 Suggested fully remote proof-test using reference reflector (High Level Supervision) with AMS Device Manager and handheld communicator

The suggested proof-test described below will detect 74 percent of possible DU failures in the Rosemount 5300 Level Transmitters.

Procedure

1. Bypass the safety function and take appropriate action to avoid a false trip.
2. Perform High Level Supervision test.
 - a) Select **Configure** → **Alert Setup** → **Level Supervision**.
 - b) Select **Start/Stop Test Mode**.
 - c) Verify that the output from the device corresponds to the alarm limit in the host system.
 - d) End test mode by clicking **Start/Stop Test Mode**.
The device will automatically exit the test mode after 30 minutes [default].
3. Remove the bypass and otherwise restore normal operation.

7 Preventive maintenance

7.1 Review the reference reflector echo properties

The reference reflector echo may be affected by the environment in the vessel over time. If there is buildup on the probe, this may affect the reference reflector echo. You can review the reference reflector echo properties to make sure they are not deviating from the time of calibration.

Procedure

1. In Rosemount Radar Master, select **Setup** → **Advanced** → **Level Supervision**.
2. In the **Reflector Measurement Details** section, review echo properties.

Variable	Description
Reflector Echo Distance	Distance to reference reflector echo.
Reflector Echo Amplitude	Amplitude of reference reflector echo.
Calibrated Reflector Echo Distance	Distance to reference reflector echo at time of calibration.
Calibrated Reflector Echo Amplitude	Amplitude of reference reflector echo at time of calibration.
Difference Calibrated/Actual Distance	Difference between the calibrated and actual distance to the reference reflector.

Note

The product surface level should be at least 500 mm below the reference reflector when reviewing the echo information.

3. Verify that Reflector Echo Amplitude is within applicable range depending on application:

Device mounting type	Reflector Echo Amplitude
3-in. to 6-in. pipe/chamber (inner diameter)	Between -700 mV and -2200 mV.
8-in. pipe/chamber or bigger (inner diameter) or Open tank (tank without pipe)	Between -700 mV and -1800 mV

- a) Inspect the reference reflector if the value is close to boundaries and deviating from Calibrated Reflector Echo Amplitude.
- b) Clean the reference reflector in case of buildup.

8 Service and troubleshooting

8.1 Calibration fails

Cause

The device is not able to identify the reference reflector.

Recommended actions

1. In Rosemount Radar Master, select **Setup** → **Echo Curve**.
2. Read the echo curve and locate the negative peak from the reference reflector (at the proximity of the physical distance to the lower side of the reference reflector). The negative peak will follow immediately after a positive peak of about the same amplitude.
3. Hover with the mouse pointer at the negative peak and record the distance and amplitude of this peak.

Figure 8-1: Negative Peak

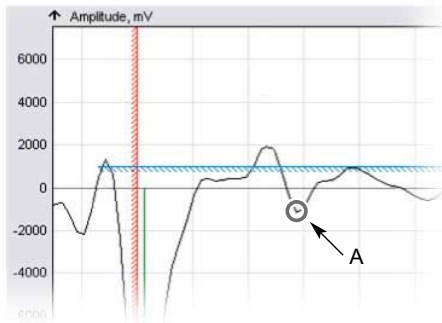

A. Hover with mouse pointer here

4. Verify that the amplitude is within applicable range depending on application:

Device mounting type	Reflector Echo Amplitude
3-in. to 6-in. pipe/chamber (inner diameter)	Between -700 mV and -2200 mV
8-in. pipe/chamber or bigger (inner diameter) or Open tank (tank without pipe)	Between -700 mV and -1800 mV

- Disturbing echoes from process connections, nozzles, etc., may interfere with the reference reflector echo. Move the reference reflector (see section [Change reference reflector position](#)) if there are disturbances affecting the reference reflector echo.
- Use the short reference reflector if the amplitude is too strong.
- Use the long reference reflector if the amplitude is too weak.

Contact your local Emerson representative if the other reference reflector type is required for your application.

8.2 Change reference reflector position

In case the alarm limit in the host system must be moved outside the high level alarm limit interval given by the reference reflector at the current position, then it is necessary to move the reference reflector to a new position to make full use of the High Level Supervision functionality.

Procedure

1. In Rosemount Radar Master, select **Setup** → **Advanced** and then click the **Level Supervision** tab.
2. Clear the **Use High Level Supervision** checkbox and click **Store** to turn off the High Level Supervision function.
3. Physically slide the reference reflector to the new position.
4. Tighten the screws on the reference reflector.

Postrequisites

Follow the instructions in the [Configure the High Level Supervision function](#) section to re-configure the High Level Supervision function.

8.3 Set surface threshold manually around reference reflector

The Surface Threshold is pre-configured at factory for transmitters with High Level Supervision option and it is typically not necessary to make manual adjustments to the threshold. Manual adjustments are necessary in the following cases:

- High Level Supervision is retrofitted on existing transmitter
- Configuration in transmitter has been reset to factory settings
- Threshold around reference reflector has been overwritten by other actions

Procedure

1. In Rosemount Radar Master, select **Setup** → **Echo Curve**.

2. Drag and drop the Amplitude Threshold Curve (ATC) points to adjust the Surface Threshold in an interval around the reflector. Adjust ATC points depending on application:

Device mounting type	Surface Threshold
3-in. to 6-in. pipe/chamber (inner diameter)	1500 mV
8-in. pipe/chamber or bigger (inner diameter) or Open tank (tank without pipe)	900 mV

Tip

You may zoom in by left clicking and dragging in the echo curve to increase resolution of the ATC.

Figure 8-2: Surface Threshold

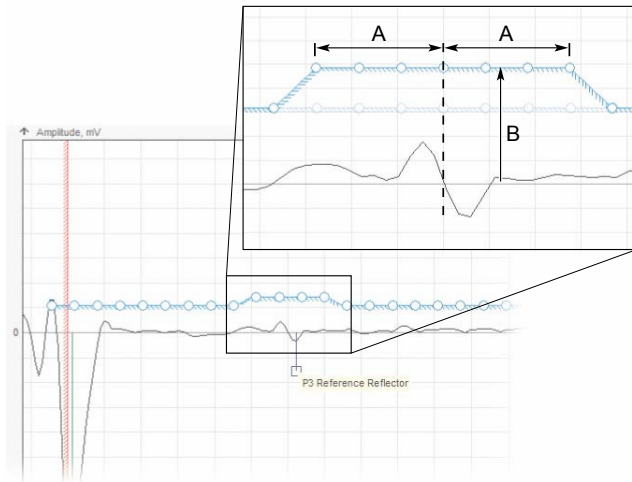

- A. 10 in. (250 mm)
- B. 900 mV or 1500 mV

3. Click **Store** to save ATC to device.

9 Product Data Sheet for High Level Supervision

9.1 Ordering information

- ✓ For models 5301 and 5302
- ✓ Only available with HART 4-20 mA output (code H)
- ✓ Only available with standard operating temperature and pressure (code S)
- ✓ Only available with 316L SST (EN 1.4404) material of construction (material model code 1)
- ✓ Only available with flexible single lead probes, 4 mm (probe type 5A, 5B)
- ✗ Not available with remote housing mounting (code B1, B2, B3)

See the Rosemount 5300 Level Transmitter [Product Data Sheet](#) for complete ordering information.

9.2 Performance specification

Measurement Performance	
Reference accuracy close to reference reflector ⁽¹⁾	Measurement accuracy depends on the dielectric constant of the product. <ul style="list-style-type: none"> • Water (dielectric constant = 80): +/- 1 in. (25 mm) • Oil (dielectric constant = 2): +/- 1.8 in. (45 mm)
Reference accuracy in other regions	See Rosemount 5300 Product Data Sheet for accuracy in other regions
Offset error	< 0.2 in. (5 mm)
Interface Measurement	Interface level reported by device can in some cases be incorrect when product level is above the reference reflector Interface measurement is unaffected when product level is below the reference reflector
Probe end projection	Not available
Environment	
Ambient temperature range during operation	-40 °F to 158 °F (-40 °C to +70 °C)
Ambient temperature range during calibration	For 3-in. to 6-in. pipe installations: 32 °F to 104 °F (0 °C to +40 °C)
	For 8-in. or bigger pipe installations or Open tank: -4 °F to 122 °F (-20 °C to +50 °C)
Product dielectric constant	For 3-in. to 6-in. pipe installations: greater than 2.4
	For 8-in. or bigger pipe installations or Open tank: greater than 2.0
Tank material	Recommended for installation in metallic tanks

(1) From 9.8 in. (250 mm) above upper side of reference reflector until 9.8 in. (250 mm) below lower side of reference reflector.

9.3 High Level Supervision Alarming

The High Level Supervision function will monitor the reference reflector echo and determine if the level is at or above the reference reflector. At the same time, the normal measurement logic will identify the product level. The device will signal an alarm in case of a mismatch between the High Level Supervision logic and the normal measurement logic (the output for this alarm is configurable).

Table 9-1: Different Measurement Scenarios and Resulting Output



Measurement condition ⁽¹⁾	Analog Output	Digital alert (HART® command 48)	HLS Alarm indicated on device display
RR not verified and product surface identified below RR	Alarm (configurable)	Set	Yes
RR not verified and no product surface found	Alarm (configurable)	Set	Yes
RR verified and product surface identified below RR	Output corresponding to level measurement	Cleared	No
RR verified and no product surface found	Output corresponding to empty tank	Cleared	No
RR not verified and product surface identified at or above RR	Output corresponding to level measurement	Cleared	No

(1) Reference reflector abbreviated as RR in table. RR verified means that reference reflector has been found at the calibrated distance.

The reaction time from when the alarm condition is detected to when it is reported by the device is less than 15 seconds.



Global Headquarters

Emerson Automation Solutions
6021 Innovation Blvd.
Shakopee, MN 55379, USA
 +1 800 999 9307 or +1 952 906 8888
 +1 952 949 7001
 RFQ.RMD-RCC@Emerson.com

North America Regional Office

Emerson Automation Solutions
8200 Market Blvd.
Chanhassen, MN 55317, USA
 +1 800 999 9307 or +1 952 906 8888
 +1 952 949 7001
 RMT-NA.RCCRF@Emerson.com



Latin America Regional Office

Emerson Automation Solutions
1300 Concord Terrace, Suite 400
Sunrise, FL 33323, USA
 +1 954 846 5030
 +1 954 846 5121
 RFQ.RMD-RCC@Emerson.com

Europe Regional Office

Emerson Automation Solutions Europe
GmbH
Neuhofstrasse 19a P.O. Box 1046
CH 6340 Baar
Switzerland
 +41 (0) 41 768 6111
 +41 (0) 41 768 6300
 RFQ.RMD-RCC@Emerson.com

Asia Pacific Regional Office

Emerson Automation Solutions
1 Pandan Crescent
Singapore 128461
 +65 6777 8211
 +65 6777 0947
 Enquiries@AP.Emerson.com

Middle East and Africa Regional Office

Emerson Automation Solutions
Emerson FZE P.O. Box 17033
Jebel Ali Free Zone - South 2
Dubai, United Arab Emirates
 +971 4 8118100
 +971 4 8865465
 RFQ.RMTMEA@Emerson.com

 [Linkedin.com/company/Emerson-Automation-Solutions](https://www.linkedin.com/company/Emerson-Automation-Solutions)

 [Twitter.com/Rosemount_News](https://twitter.com/Rosemount_News)

 [Facebook.com/Rosemount](https://www.facebook.com/Rosemount)

 [Youtube.com/user/RosemountMeasurement](https://www.youtube.com/user/RosemountMeasurement)

©2019 Emerson. All rights reserved.

Emerson Terms and Conditions of Sale are available upon request. The Emerson logo is a trademark and service mark of Emerson Electric Co. Rosemount is mark of one of the Emerson family of companies. All other marks are the property of their respective owners.