

MODEL NO.

TVL-E22GNMM

PRODUCT LINE

Discrete Valve Monitor

SPECIFICATIONS

Model	TVL, Tropicalized aluminum base & lid
Bus/Sensor	(2) P&F NJ2-V3-N
Area Classification	Class 1, Div. 2, Groups A,B,C&D; Class II, Div. 2, Groups F&G; Type 4, 4X, Ex nA nC IIC T4/T3 Gc, Ex tc IIIC T70°C/T115°C Dc IP64
Visual Display	90° Green Open / Red Closed
Shaft	NAMUR, 304 Stainless Steel
Conduit Entries	(2) M20
O-rings	Silicone
Temperature Rating	-50°C to 60°C

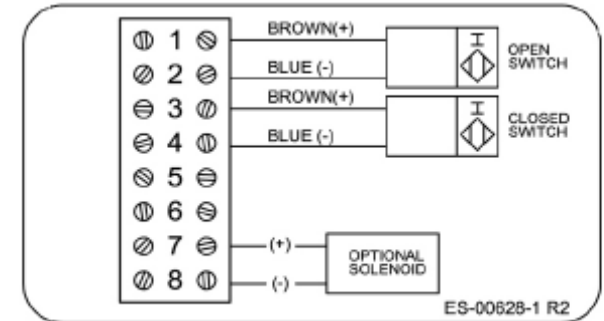

Current as of Jan 9, 2015 - subject to change without notice

TOPWORX

TopWorx, Inc.
3300 Fern Valley Rd.
Louisville, KY 40213

(502) 969-8000 ph.
(502) 969-5911 fax
www.topworx.com