

Installation Operation & Maintenance Instructions

MAC050515 EN Rev. C
May 2016

Hytork XL



Table 1 Applicable Models:

XL 26	XL 281	XL 2586
XL 71	XL 426	XL 4581
XL 131	XL 681	
XL 186	XL 1127	
XL 221	XL 1372	

1 Important Safety Procedures

Installation, adjustment, putting into service, use, assembly, disassembly and maintenance of the Actuator is strictly reserved to qualified personnel.

Before installation, operation and maintenance, read the relevant sections of:

- This manual
- Quick Reference Guide: DOC.QRG.XL

Caution: Always disconnect the Air and Electrical supplies before carrying out any form of maintenance on an Actuator.

Caution: When removing any ball valve or plug valve assemblies from a pipe system, isolate the piping system on which the Actuator is installed and relieve any media pressure that may be trapped in the valve cavities before removing the Actuator for maintenance.

Caution: Always contain the Spring tension with HYTORK Retractor Rods as explained in Section 9 (Disassembly procedure). Follow instructions for using the Retractor Rod carefully. Only HYTORK manufactured or approved Retractor Rods are to be used for Spring removal. As with any threaded tool that is frequently used Retractor Rods should be checked to ensure that the threads are not worn or damaged in any way and greased regularly. Any damaged or worn Rods must not be used and must be destroyed.

Never attempt to 'BLOW OUT' the Pistons or the End caps from the Actuator Body by using air pressure.

Never turn the stop screws completely out when the actuator is under pressure

Numbers in brackets (#) refer to parts on the exploded view drawing (Fig. 5).

All HYTORK XL Spares Kits are supplied with SAFEKEY assemblies (13/14) cut to an exact length which will fit the circumference of the End Cap (21) when fully assembled into the Actuator. Any shortened SAFEKEY must not be used. If in doubt contact Emerson Process Management or your local HYTORK Stocking Distributor.

Read the relevant sections carefully before continuing.

1.1 Warehouse storage

HYTORK Actuators should be stored in a clean, dry warehouse, free from excessive vibration and rapid temperature changes.

Actuators should not be stored on any floor surface.

1.2 On site storage

HYTORK actuators should be stored in a clean, dry warehouse, free from excessive vibration and rapid temperature changes.

Prevent moisture or dirt entering the actuator. Plug or seal both air connection ports.

Important! Failure to follow proper storage guidelines will void warranty

1.3 Lifting instructions

- Use lifting equipment as required by national or local legislation.
- Use lifting straps to lift the assembly of actuator and valve.
- Do not attach lifting straps to only the actuator, to lift the assembly of actuator and valve.

Table 2 Weight of Actuators

Model	Double Acting		Spring Return with S80 Springs	
	Kg	Lbs	Kg	Lbs
XL26	1.39	3.06	1.53	3.37
XL71	2.39	5.27	2.78	6.13
XL131	3.90	8.60	4.76	10.49
XL186	4.77	10.52	5.45	12.02
XL221	6.19	13.65	7.76	17.11
XL281	7.02	15.47	9.90	21.83
XL426	7.30	16.10	12.50	27.56
XL681	8.80	19.40	22.50	49.60
XL1127	22.00	48.50	36.00	79.37
XL1372	27.00	59.52	46.60	102.73
XL2586	46.00	101.41	79.00	174.16
XL4581	83.00	182.98	142.00	313.05

2 ATEX instructions for use in (potential) explosive areas

2.1 Intended use

The Hytork XL series pneumatic actuators are a Group II category 2 equipment and intended for use in areas in which explosive atmospheres caused by mixtures of air and gases, vapours, mists or by air/dusts are likely to occur. Therefore it may be used in (ATEX) classified Zones 1, 2 (Gasses) and/or 21, 22 (Dust).

2.2 Safety instructions

- a Assembly, disassembly and maintenance, is only allowed at the actuator, when, at the time of the activity, there is not an explosive mixture.
- b Prevent entry of explosive mixtures into the actuator. We suggest utilizing a solenoid with a "breather" function on spring return actuators when used in potentially explosive atmospheres.
- c The plastic position indicator caps are approved for ATEX gas group IIB areas. In areas where ATEX gas group IIC requirements apply, do not use the plastic position indicator cap of sizes XL426 up to XL4581, to avoid build up of static electricity.
- d In order to avoid increasing dust explosion risk, periodically clean dust deposits from all equipment.
- e When equipment is installed in a hazardous area location (potentially explosive atmosphere), prevent sparks by proper tool selection and avoiding other types of impact energy.
- f Proper care must be taken to avoid generation of static electricity on the non-conductive external surfaces of the equipment (e.g. rubbing of surfaces, etc.).
- g HYTORK XL actuators do not have an inherent ignition source due to electro-static discharge, but explosion hazard may be present due to the discharge of static electricity from other valve assembly components.
 - To avoid personal injury or property damage, make sure that the valve is grounded to the pipeline before placing the valve assembly into service.
 - Use and maintain alternate shaft-to-valve body bonding, such as a shaft-to-body bonding strap assembly.

2.3 Maximum temperatures

Temperature			Valid for actuator model
Ambient range	ATEX class	TX (ATEX surface temperature)	
-20..75°C	T6	T85°C (185°F)	Standard Temperature models
-20..80°C	T5	T90°C (194°F)	
-20..80°C	T1...T4	T90°C (194°F)	
-20..75°C	T6	T85°C (185°F)	High Temperature models
-20..90°C	T5	T100°C (212°F)	
-20..120°C	T1...T4	T130°C (266°F)	
-40..75°C	T6	T85°C (185°F)	Low Temperature models
-40..80°C	T5	T90°C (194°F)	
-40..80°C	T1...T4	T90°C (194°F)	
-20..250°C for 2 hours	T2	T260°C 500°F)	Tunnel application models

Note:

- a The actual maximum surface temperature depends not on the equipment itself, but mainly on operating conditions like e.g. the temperature of the supply media.
- b The specified values are valid with the following conditions:
 - Maximum working frequency of the actuator is 1Hz at a maximum of 50 cycles per hour and at maximum load.

3 Operating Media, Pressures and Temperatures

3.1 Operating media

- a Use clean, dry or lubricated air or inert gas.
- b Maximum pressure : 8 barg / 116PSI

Note:

On applications where the spring stroke of single acting actuators is pneumatically operated, the maximum pressure is 6.5 bar / 95PSI

- c Dew point 10 K below operating temperature.
- d For subzero applications take appropriate measures.

3.2 Operating Temperature range

- a Using standard seals and greases the operating temperature range is -20°C to + 100°C (-4°F to +212°F) as is indicated on the product label.
- b Other medias and temperatures may be used but consult your local Hytork supplier for confirmation as to suitability.

4 Actuator to Valve Installation

The Pinion drive, coupling device and Valve Stem should be centered and concentric to prevent any side loading to the Pinion Radial Bearing and Valve Stem Seat area. Ensure that the coupling shaft to be operated is a tight but free sliding fit into the female drive in the Actuator Pinion (19).

4.1 Bi-directional Travel Stops

Hytork XL actuators have two travel stops (22, 23 and 24) for setting accurately the travel and the open and closed positions. XL2586 and XL4581 can be fitted with the optional Bottom Stop Block for setting the travel.

The actuator has a factory set stroke of 90°. The adjustable stroke range of the actuator is :

- at closed (0°) position : -3° to +7°
- at open (90°) position : -83° to +93°

REMARK:

- If the actuator is assembled for reverse operation, instead of standard operation, Stop "1" will adjust the "open" position and stop "2" the "closed" position.

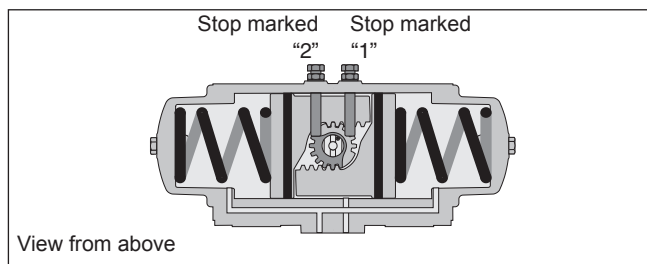

View from above

Fig. 1 Travel stops

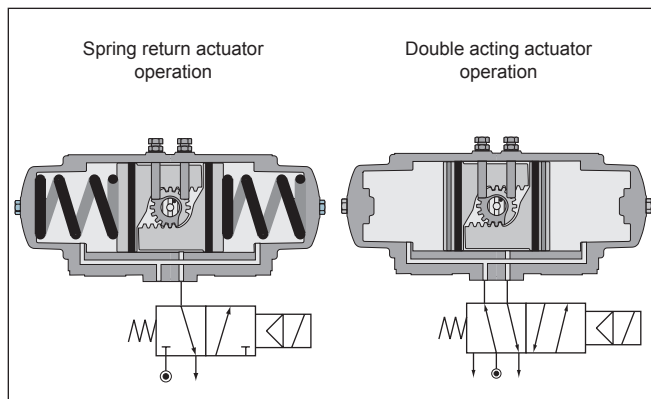

Fig. 2 Solenoid operation

4.2 Travel Stop Adjustments

- 1 Operate valve/actuator assembly to the open position.
- 2 Remove air supply.
- 3 Slacken locknut (24) on the “closed” stop (marked “2”).
- 4 Turn the “closed” stop clockwise to reduce or counter clockwise to increase the travel.
- 5 Tighten the lock nut.
- 6 Connect air and check that the position is correct. If not repeat from 2.
- 7 Operate valve/actuator assembly to the “closed” position.
- 8 Remove air supply.
- 9 Adjust “open” travel stop (marked “1”) as from step 3 to 6.

5 Piping Instructions

(See Fig. 2) All Actuators can be either piped with solid or flexible tubing with the solenoid valve mounted remotely from the actuator or by mounting a NAMUR designed solenoid valve DIRECTLY onto the NAMUR mounting pad on the side of the actuator.

6 Solenoid Valves on Spring Return Actuators

(See Fig. 3) It is recommended that on Spring Return Actuators, the HYTORK “CATS” Solenoid Valves are used. These Valves are specially designed to prevent contamination of the internals of the Actuator by dirt from the atmosphere. This increases the working life of the Actuator which reduces down time and maintenance periods.

7 Position feedback

All position feedback or positioning accessories, that comply to the VDI/VDE 3845 (NAMUR) standard, can be mounted easily on top of Hytork XL actuators. To access the pinion top, remove the position indicator.

8 Spares Recommendations

When disassembling and carrying out maintenance work on the XL Actuator, a HYTORK Spares Kit must be used to replace all ‘O’ Rings, DURASTRIP Bearings, Washers etc. This Kit is available from Emerson Process Management or its Stocking Distributors.

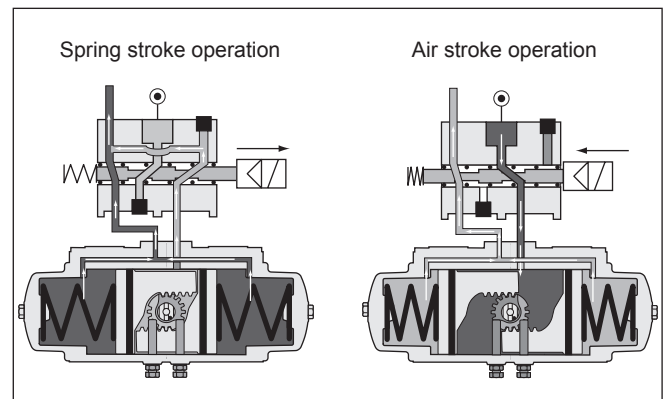

Fig. 3 HYTORK “CATS” Solenoid Valve

9 Disassembly procedure

9.1 End cap and springs dis-assembly on Spring Return actuators

- 1 Release Locking Nuts (24) and remove both Travel Stops (22) and Thread Seals (23) or ‘O’-rings (23a).
- 2 Remove the Indicator (7) from the top of the Pinion (19) For XL26 to XL221 use an Allen key size 4mm. For the larger sizes the Indicator can be pulled from the pinion top.
- 3 Remove both Sealing Bolts (28) and seals (29) from the End Caps (21).
- 4 Place both the HYTORK Retractor Rods through the hole in the End Caps and screw the Rods into :
 - For XL 26 to XL 681 the Pistons (20)
 - For XL 1127 to XL4581 the Retractor plate (20a, see also Fig 5) until travel is stopped (DO NOT OVERTIGHTEN) and take care the nut and washer being free of the End Cap face.
- 5 Turn back the Rod 1/2 turn.
- 6 Screw the adjusting nut and washer by hand clockwise down the Retractor Rod until they come up against the face of the End Cap.
- 7 Prevent the “hold-nuts “ to rotate by one wrench. Use another wrench, to screw both adjusting nuts half turn at a time (see Fig. 5) clockwise down the Rods until the end cap loosens (Maximum; approximately two complete turns). This draws the;
 - For XL 26 to XL681 the Pistons (20)
 - For XL 1127 to XL4581 the Retractor plate (see also Fig 5) to the end caps (21) and compresses the springs. This Spring-compression, releases the Spring force and un-locks the SAFEKEY for removal.
- 8 Rotate the Caps to ensure that the Springs are retracted; if the Cap will not turn easily, a gentle tapping with a plastic hammer against the endcap will loosen the end cap.
- 9 Unscrew the two slotted SAFEKEYS (13/14), and gently pull each SAFEKEY from the Body. If the SAFEKEY resists removal, gently tap the End Cap with a soft hammer to assist release.
- 10 When both SAFEKEYS have been removed, use a wrench to rotate the Pinion, driving the pistons (20) apart until they partially push the End Caps from the Body.
 - For XL 26 to XL681 the Pistons (20), springs and end cap will come out
 - For XL 1127 to XL4581 the Retractor plate, springs and end cap will come out.

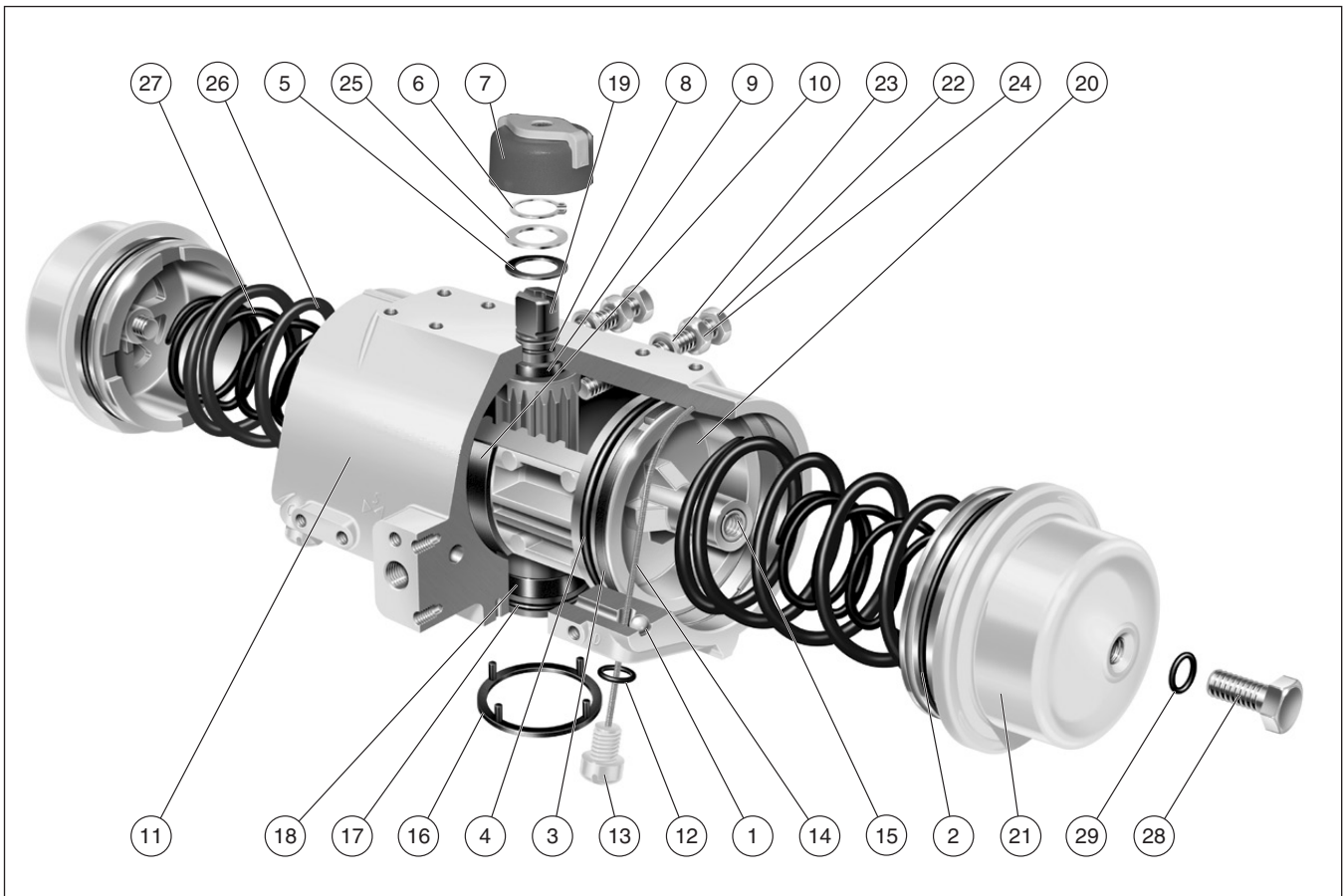

Fig. 4 Hytork XL Actuator Parts

Table 3 Parts and materials

Pos.	Description	Material	Qty	Note:	Pos.	Description	Material	Qty	Note:
1	Ball Bearing	Chromium Steel	2	-	17	'O' Ring (Pinion bottom)	Nitrile	1	-
2	'O' Ring (End Cap)	Nitrile	2	-	18	Bearing (Pinion bottom)	Acetal M90	1	-
3	Wear Ring (Piston)	Acetal M90	2	-	19	Pinion	Steel	1	-
4	'O' Ring (Piston)	Nitrile	2	-	20	Piston	Aluminum alloy	2	-
5	Thrust Bearing (Circlip)	Acetal M90	1	-	20a	Retractor plate	Aluminum alloy	2	1
6	Circlip	Spring Steel	1	-	21	End Cap (DA & SR)	Aluminum alloy	2	2
7	Indicator	Nylon	1	-	21a	End Cap DA	Aluminum alloy	2	1
7a	Indicator screw	Stainless steel	1	3	22	Travel Stop	Stainless Steel	2	5
8	'O' Ring (Pinion top)	Nitrile	1	-	23	Thread Seal	Steel/Rubber	2	3/6
9	Bearing (Pinion top)	Acetal M90	1	-	23a	'O' Ring (Travel Stop)	Nitrile	2	4
10	Bearing block (Piston)	Acetal M90	2	-	23b	Washer (Travel Stop)	Stainless Steel	2	4
11	Body	Aluminum alloy	1	-	24	Locking Nut	Stainless Steel	2	5
12	'O' Ring (SAFEKEY)	Nitrile	2	-	25	Thrust Washer (Circlip)	Stainless Steel	1	-
13	SAFEKEY Head	Grivory	2	-	26	Spring Outer	Spring Steel	2	-
14	SAFEKEY Wire	Stainless steel	2	-	27	Spring Inner	Spring Steel	2	-
15	Thread Insert	Steel	2	-	28	Sealing Bolt (End Cap)	Steel	2	-
16	Location Ring	Acetal	1	-	29	'O' Ring (Sealing Bolt)	Nitrile	2	-

Notes:

- 1 on XL 1127 to 4851
- 2 on XL 26 to XL 681
- 3 on XL 26 to XL 221
- 4 on XL 281 to XL 1372
- 5 on XL 26 to XL 1372
- 6 on XL 26/71 equipped with extra nylon washer

11 To keep the Spring Pack Assembly intact (see Fig. 5), leave the Retractor Rod in place. To disassemble the Spring Pack, unscrew the adjusting nut on the Retractor Rod relieving the Spring force, while preventing the rod from turning with a wrench on the hold nuts.

9.2 Changing spring sets on XL26 to XL681

12 If only the springs set of the actuator has to be changed, perform steps 1 to 9. These steps can be performed at both end caps simultaneously or at one end cap only.

After step 9 unscrew the adjusting nut on the Retractor Rod relieving the Spring force, while preventing the rod from turning with a wrench on the hold nuts.

9.3 End cap disassembly on double acting actuators

13 Remove the SAFEKEY as described previously. The Retractor Rod is not required for Double Acting Actuators. Remove the End Caps by pulling them free from the Body keeping them square to the end face of the Body.

9.4 Piston disassembly

14 Rotate the Pinion using a wrench to drive the Pistons apart and remove from the Body by pulling the Pistons.

9.5 Pinion disassembly

15 Remove the snap ring (Circlip) (6), Thrust Washer (25) and DURASTRIP Thrust Bearing (5) from the top of the Pinion and CAREFULLY push the Pinion from the Body through the bottom. Take care that the Pinion does not damage the pinion bores on removal. If necessary, remove any burrs, etc. from the top of the Pinion before removal.

16 Carefully remove Pinion Top Bearing (9) from the Body.

9.6 Inspection

17 Clean and examine all parts for damage and wear. Emerson Process Management recommends 'O' Rings, DURASTRIP Bearings, SAFEKEYS, Washers, etc. are replaced using a HYTORK XL Spares Kit.

10 Assembly Instructions

Note: The grease used in ALL HYTORK Standard Model Actuators is a Lithium Based Grease. Check with EMERSON PROCESS MANAGEMENT for high and low temperature applications.

10.1 Pinion assembly

- 1 Lightly grease all 'O' Rings, 'O' Ring grooves, bearing grooves and Pinion.
- 2 Assemble the Top Pinion Bearing (9) to the Pinion, ensuring that the recess openings are facing away from the gear form, then assemble items (8), (17) and (18).
- 3 Lightly grease the Pinion bores in the Body (11) and insert the Pinion being careful not to damage the 'O' Rings.
- 4 When the Pinion is in place, install the DURASTRIP Thrust Bearing (5), Thrust Washer (25) and the snap ring (Circlip) (6) into the narrow groove at the top of the Pinion (ensuring the snap ring fits properly into the groove).
- 5 Only open the snap ring (Circlip) enough to just clear the Pinion diameter as opening too far will damage the snap ring. If damage occurs replace with a new part.

IMPORTANT: The snap ring (Circlip) has one side with bevelled edges which must go DOWN onto the Thrust Washer (25); the square edge side must face UPWARDS.

10.2 Alignment of pinion for correct piston assembly.

Standard rotation is clockwise with the Pistons moving towards each other (When viewed from above the slot at the top of the Pinion, see Fig. 6).

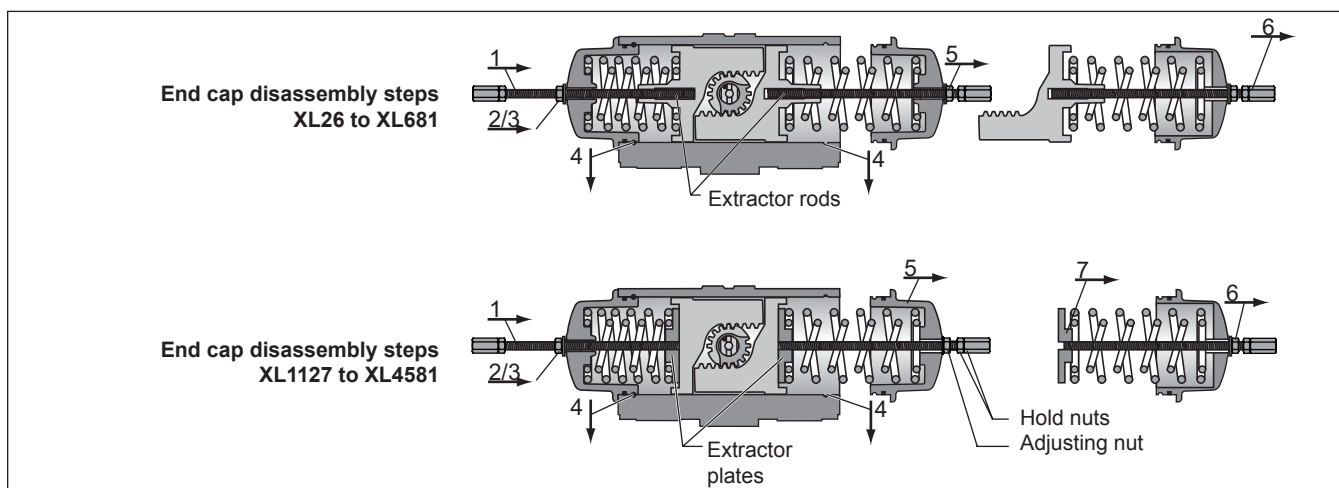

Fig. 5 End Cap Disassembly

10.3 Piston assembly

10.3.1 Clockwise rotation

(Pistons moving inwards, Fig. 6).

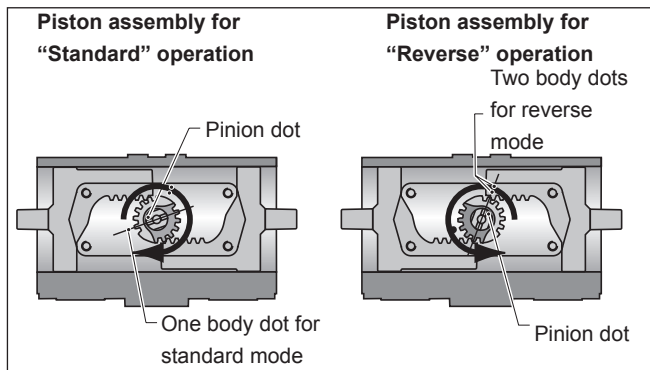

Fig. 6 Pinion alignment

- 6 Align the Pinion by lining up the center of the NAMUR slot in the top of the Pinion with the single dot on the Body. The top of the Pinion is marked with a single identification dot to indicate the correct orientation of the stop faces.
- 7 Lightly grease all Piston grooves, gear form and Piston 'O' Rings (4) and fit the 'O' Ring (4) and Wear Ring (3) to the Piston.
- 8 Fit the Bearing Block (10) to the back of the Piston.
- 9 Grease the Actuator body bore.
- 10 Insert the Pistons into the bore, ensuring the piston racks line up with the pinion gear. (The part number in the front face of the Piston must be lined up parallel to the Pinion).
- 11 Push both Pistons together until they are both in contact with the Pinion, so that when the Pinion is rotated clockwise the Pistons are drawn together. When the Pistons are together and the racks are correctly engaged with the Pinion, the top Pinion drive flats should be at right angles to the axis of the Body.

10.3.2 Counter-Clockwise rotation (Pistons moving inwards, Fig. 7).

- 12 Align the NAMUR slot in the top of the Pinion with the two dots on the Body and assemble the pistons so that the Pinion rotates anti-clockwise as the Pistons are drawn together.

10.4 Travel stop assembly (See Fig. 1).

- 13 With the Pistons together, screw in the CLOSING (cast identity number 2) Travel Stop (22), complete with Locking Nut (24) and Thread Seal (23), until it comes into contact with the Pinion stop face.
- 14 Rotate the Pinion through 90° only, driving the Pistons apart and screw in the OPENING (cast identity number 1) Travel Stop (22), complete with Locking Nut and Thread Seal, until it comes into contact with the pinion stop face.
For individual position requirements see chapter 4.

10.5 End cap assembly on double acting actuators.

- 15 Install the SAFEKEY 'O' Ring seals (12) to the SAFEKEY heads (13).
- 16 Lightly grease the End Cap 'O' rings (2), the End Cap grooves and the ends of the Body bore.
- 17 Taking one of the End Caps install its 'O' Ring and insert it into the Body.

- 18 Holding the SAFEKEY close to the entry hole (cast identity letter C or D) to prevent kinking, insert the SAFEKEY into the hole and gently push into place.
- 19 With the SAFEKEY Head in contact with the Body, tighten with a screw driver to gently compress the 'O' Ring and create a pressure seal.
- 20 Repeat the operation for the other End Cap. With the Pistons together, mount the Position Indicator (7) to the top of the Pinion.

10.6 Spring Return Actuators

10.6.1 Spring set adjustments

The actual selection of the correct spring set can be done by either referring to the torque charts given in the literature on Spring Return Actuators or by consulting your local HYTORK representative. After selecting the appropriate spring set arrange the springs as indicated below.

Table 4 Spring Rating Chart

Spring set	Side of actuator	Outer	Inner
S40	Left	S20	
	Right	S20	
S50	Left	S30	
	Right	S20	
S60	Left	S30	
	Right	S30	
S70	Left	S20	S20
	Right	S30	
S80	Left	S20	S20
	Right	S20	S20
S90	Left	S30	S20
	Right	S20	S20
S1C	Left	S30	S20
	Right	S30	S20

Spring Colour Coding

- S20 Inner = Green
- S20 Outer = Pink
- S30 Outer = Brown

10.6.2 Installing the Springs.

- 1 - For XL 1127 to XL4581 place the Retractor plate on top of the piston.
- 2 Insert the Springs (26/27) into the face of the Piston and then the End Cap onto the Springs.
- 3 Pass the correct HYTORK Retractor Rod through the End Cap (Fig.6) and screw it into
 - For XL 26 to XL681 the Pistons (20)
 - For XL 1127 to XL4581 the Retractor plate.
- 4 Line up the End Cap so that the safety symbol is correctly positioned for easy reading.
- 5 Prevent the "hold-nuts" to rotate by one wrench. Use another wrench, to screw the adjusting nut on the HYTORK Retractor Rod in until the End Cap is completely engaged in the Body.
- 6 It will be necessary to push the End Cap into the Body to overcome the 'O' Ring compression.
- 7 When the End Caps are in place and the SAFEKEYS fitted correctly, remove the HYTORK Retractor Rods and replace the Sealing Bolts (28) and seals (29).

11 Testing the HYTORK Actuator

Using compressed air at 80-100 psi (5.5 - 7 bar) check the seal areas with soapy water, ensuring there are no leaks and that the Pinion rotates smoothly over its full travel.

11.1 Testing and Cycling of Infrequently Used or Stored Actuators

Actuators not in current use (i.e. Actuators in storage or stock and/or not operated for at least a 3 month period), should be cycled a minimum of ten times and tested against the possible 'pre-set' of the seals. This is a safety precaution recommended by the Seal manufacturers.

12 Retractor Rods

12.1 Spring Removal System Board.

HYTORK'S "SPRING REMOVAL SYSTEM BOARD" contains a full set of Retractor Rods so that any size of Actuator can be disassembled on site.

Standard spare parts kits for XL26 to 221 contain the required Retractor Rods. For XL281 to XL4581 separate Retractor Rod kits are available. These Rods are not included in the spare parts kits but are separately available.

Ask your local HYTORK representative or Stocking Distributor of HYTORK Products for details.

⚠ IMPORTANT:

- The HYTORK Retractor Rod tools are specially designed for the safe removal of the Spring Return End Cap modules. Only HYTORK manufactured or approved rods are to be used for Spring End Cap removal.
- As with any threaded tool that is used frequently, Retractor Rods should be checked to ensure that the threads are not worn or damaged in any way and greased regularly. Any damaged or worn Rods must not be used and must be destroyed.
- Retractor Rods must be made to the design specification for safety reasons. EMERSON PROCESS MANAGEMENT can not take any responsibility for any other design.

13 Service

It is the policy of Emerson Process Management to give the best possible service to our customers. We are happy to assist you in any way we can and if you have any questions about HYTORK Actuators or other HYTORK Products please do not hesitate to contact any Valve Automation Center of Emerson Process Management or your local HYTORK Stocking Distributor.

Table 5 SAFEKEY Dimensions

Model	(in mm)		(in inches)		Thread	Length	
	Length	Diam.	Length	Diam.		mm.	inch)
XL26	157	3.175	6.18	0.125	1/4-20 UNC	215	8.46
XL71	217	3.175	8.54	0.125	1/4-20 UNC	215	8.46
XL131	267	3.175	10.51	0.125	1/4-20 UNC	215	8.46
XL186	282	3.175	11.1	0.125	1/4-20 UNC	215	8.46
XL221	317	3.175	12.48	0.125	5/16-18UNC	225	8.86
XL281	367	3.175	14.45	0.125	M10	210	8.27
XL426	377	3.175	14.84	0.125	M8	278	10.94
XL681	437	3.175	17.2	0.125	M12	363	14.29
XL1127	517	3.175	20.35	0.125	M12	416	16.38
XL1372	572	3.175	22.52	0.125	M12	416	16.38
XL2856	707	3.175	27.83	0.125	M20	500	19.69
XL4581	937	4.978	36.89	0.196	M20	600	23.62

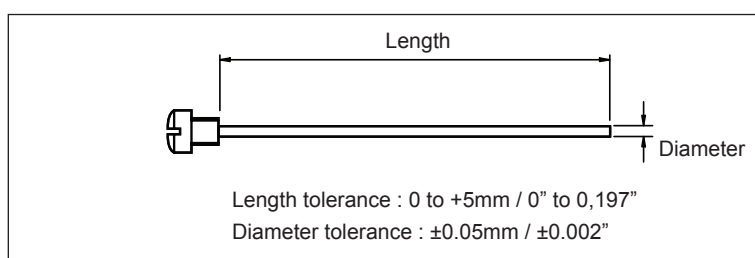

Figure 7 SAFEKEY Dimensions

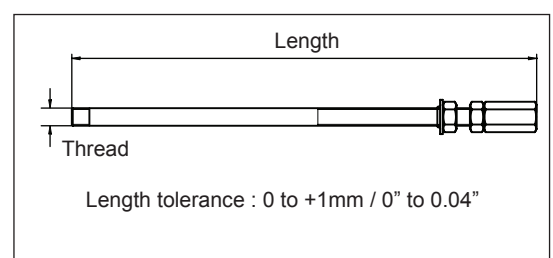

Figure 8 Retractor Rod Dimensions

Contact Us: Emerson Process Management, Valve Automation facilities at your nearest location:

North & South America

19200 Northwest Freeway
Houston, TX 77065, USA
T +1 281 477 4100
F +1 281 477 2809

2500 Park Avenue West
Mansfield, OH 44906
USA
T +1 419 529 4311
F +1 419 529 3688

13840 Pike Road
Missouri City, Texas 77489
USA
T +1 281 499 1561
F +1 281 499 8445

Av. Hollingsworth,
325, Iporanga Sorocaba,
SP 18087-105
Brazil
T +55 15 3238 3788
F +55 15 3228 3300

Middle East & Africa

P. O. Box 17033
Dubai
United Arab Emirates
T +971 4 811 8100
F +971 4 886 5465

P. O. Box 105958
Abu Dhabi
United Arab Emirates
T +971 2 697 2000
F +971 2 555 0364

P. O. Box 3911
Al Khobar 31952
Saudi Arabia
T +966 3 814 7560
F +966 3 814 7570

P. O. Box 10305
Jubail 31961
Saudi Arabia
T +966 3 340 8650
F +966 3 340 8790

P. O. Box 32281
Doha
Qatar
T +974 4 576777
F +974 4 315448

24 Angus Crescent
Longmeadow Business Estate
East P.O. Box 6908; Greenstone;
1616 Modderfontein, Extension 5
South Africa
T +27 11 451 3700
F +27 11 451 3800

Europe

Berenyi u. 72- 100
Videoton Industry Park,
Building #230
Székesfehérvár 8000
Hungary
T +36 22 530 950
F +36 22 543 700

Siemensring 112
47877 Willich
Germany
T +49 2154 499 660
F +49 2154 499 6613

25, Rue de Villeneuve
Silic – BP 40434
94583 Rungis
France
T +33 1 49 79 73 00
F +33 1 49 79 73 99

Via Montello 71/73
20038 Seregno (Milan)
Italy
T +39 0362 2285 207
F +39 0362 2436 55

6 Bracken Hill
South West Industrial Estate
Peterlee SR8 2LS
United Kingdom
T +44 191 518 0020
F +44 191 518 0032

2A Szturmowa Str
02-678 Warsaw
Poland
T +48 22 4589 237
F +48 22 4589 231

C/ Francisco Gervás, 1
28108 Alcobendas – Madrid
Spain
T +34 0913 586 000
F +34 0913 589 145

Letnikovskaya Str. 10-2
115114 Moscow
Russia and FSU
T +7 495 981 98 11
F +7 495 981 98 10

Asia Pacific

No. 9 Gul Road
#01-02 Singapore 629361
T +65 6501 4600
F +65 6268 0028

9/F Gateway Building
No. 10 Ya Bao Road
Chaoyang District
Beijing 100020
P.R.China
T +86 10 8572 6666
F +86 10 8572 6888

No.1 Lai Yuan Road
Wuqing Development Area
Tianjin 301700
P.R.China
T +86 22 8212 3300
F +86 22 8212 3308

Lot 13112, Mukim Labu
Kawasan Perindustrian Nilai
71807 Nilai, Negeri Sembilan
Malaysia
T +60 6 799 2323
F +60 6 799 9942

471 Mountain Highway
Bayswater, Victoria 3153
Australia
T +61 3 9721 0200
F +61 3 9720 0588

Delphi B Wing, 601 & 602
6th Floor, Central Avenue
Powai, Mumbai – 400 076
India
T +91 22 6662 0566
F +91 22 6662 0500

NOF, Shinagawa Konan Bldg
1-2-5, Higashi-shinagawa
Shinagawa-ku, Tokyo
140-0002 Japan
T +81 3 5769 6873
F +81 3 5769 6902

Please visit our website for up to date product data: www.Hytork.com

All rights reserved.

No part of this publication may be copied or published by means of printing, photocopying, microfilm or otherwise without prior written consent of Emerson Process Management. This restriction also applies to the corresponding drawings and diagrams.

Emerson Process Management has the right to change parts of the machine at any time without prior or direct notice to the client. The contents of this publication are subject to change without notice.

This publication is to be used for the standard version of the machine only. Thus Emerson Process Management cannot be held responsible for any damage resulting from the application of this publication to the version actually delivered to you.

For extra information as to adjustments, maintenance and repair, contact the technical department of your supplier.

This publication has been written with great care. However, Emerson Process Management cannot be held responsible, either for any errors occurring in this publication or for their consequences.

©2016 Emerson Electric Co.

HYTORK 

www.Hytork.com



EMERSON
Process Management