

# Data sheet

Sheet No.: A5.206 Rev.A  
Date: November 2009

## EL ACTUATOR WITH MODULATING POSITIONER - (Kit option)

MOD

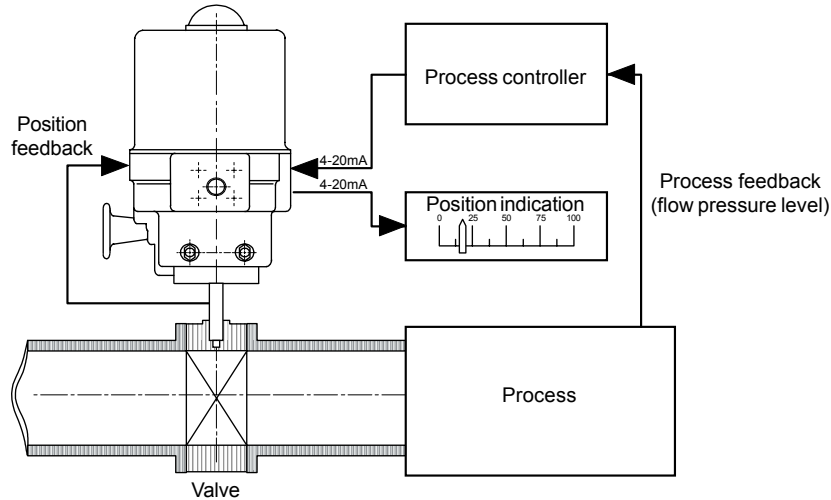

### Description

This electric actuator variation provides a modulating position control from an incoming 4 to 20 milli-Amp signal.

A very advanced solid-state circuit control board works on the comparator principle, where the incoming control signal is continuously compared to the actual position of the output shaft and signals are sent to the motor to "Open more" or "Close more", until the balanced or null position is achieved.

The valve is held in this position until a variation in signal causes a proportional movement of the output shaft.

The circuit board includes trimmers for zero, span adjustment sensitivity adjustment and provision is made for split ranging. LED's are fitted for simplified setting.

A speed control feature reduces the motor speed, by pulsing the motor, as the null position is approached. This allows greater accuracy without "Overshoot" or "Hunting".

Other standard features include a 4-20 mA position transmitter and "Lock on last position" on signal failure.

### Wiring diagram for EL100-EL1600 + MOD

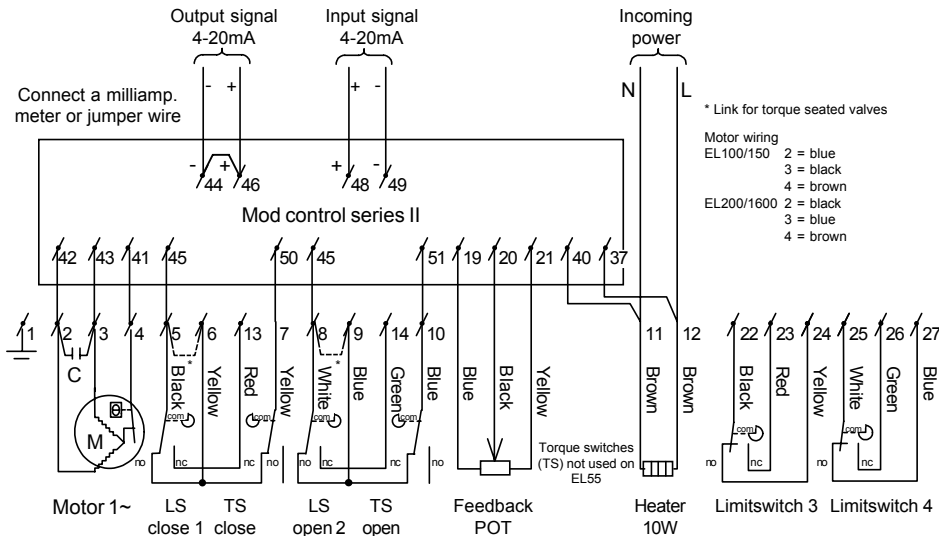

### Specification

Input Power	:	Dual 220/240 - 120 50/60 Hz
	:	Control 4 to 20 mA, adjustable
	:	0.1 to 35 mA
	:	and 0.1 to 12 mA
	:	or 12 to 35 (for split ranging)
Performance	:	Linearity 3%
	:	Hysteresis 1%
	:	Min. resolution 1%
Adjustment	:	Zero, span, sensitivity
Position indication	:	4 to 20 mA output
Temperature	:	-20°F to +158°F

### Identification

Factory Option	:	Add "MOD" to the basic actuator size
	:	eg. EL100 120/60 + MOD
Kit options	:	Actuator size is added to: "Kit, MOD"
	:	eg. Kit MOD/EL100 120/60

**EL-O-MATIC™**

www.El-O-matic.com

Copyright © Emerson Process Management. The information in this document is subject to change without notice.

Updated data sheets can be obtained from our website [www.El-O-Matic.com](http://www.El-O-Matic.com) or from your nearest Valve Automation Center **USA:** +1 813 319 0266 **Europe:** +31 74 256 10 10 **Asia-Pacific:** +65 6501 4600

**EMERSON™**  
Process Management