

# SHAFAER™

## ESD

### Emergency Shut-Down Control

*The Shafer 2-way poppet ESD Control Valve is designed for the utmost reliability in Emergency Shut-Down Control Applications*

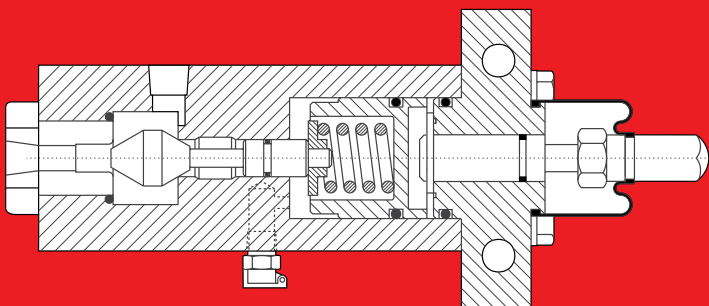

- Eliminates critical adjustments and orifices which are subject to contamination and freeze off.
- Provides positive end of stroke shut off because it is mechanically neutralized only after the valve actuator reaches the failsafe position.
- ESD Poppet Control can be used in combination with a variety of secondary control modes such as local manual or remote two way electric.
- The actuator, once in the failsafe position cannot be reset, either locally or remotely, without first re-establishing the ESD Pilot Pressure Circuit.

# EMERGENCY SHUT-DOWN CONTROL

## SEQUENCE 1 - VALVE FULLY OPEN

The ESD poppet valve (N) is mounted on top of the rotary vane actuator. In this sequence the ESD pilot pressure enters the ESD poppet valve (N) forcing the piston (O), interconnecting push pin (P) and poppet (Q) to the closed position. Power gas is held in check by the poppet (Q) and the control is in the armed position.

## SEQUENCE 2 - VALVE CLOSING

When ESD pilot pressure is vented from the pilot port, the front side of the piston (O) is vented. Power gas pressure shifts poppet (Q) allowing power gas to enter poppet block (A) under one of the pilot pistons (D). The pilot piston (D) seats the exhaust poppet (E) and unseats the power poppet (I). Power gas pressurizes the closing gas hydraulic tank (K) forcing high pressure hydraulic fluid into the actuator causing the actuator to close. The resident fluid in the actuator is forced into the opening tank (L).

## SEQUENCE 3 - VALVE FULLY CLOSED

When the valve actuator reaches the end of stroke, the mechanical actuator (R) which is attached to the actuator rotor, mechanically closes the ESD poppet valve (N) forcing the poppet (Q) into the power seat and allowing the gas hydraulic tank and actuator pressures to neutralize. The valve actuator is now in the emergency failed position. The valve actuator can only be opened when the ESD pilot is restored. After restoring the ESD pilot, this mechanical actuator (R) is no longer required to hold the ESD poppet valve (N) closed.

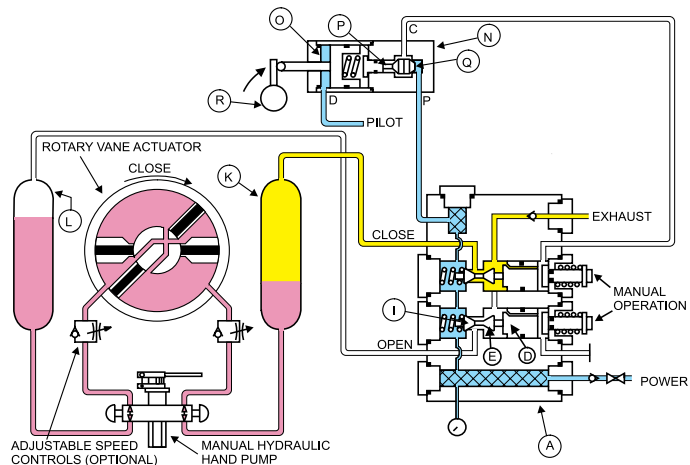
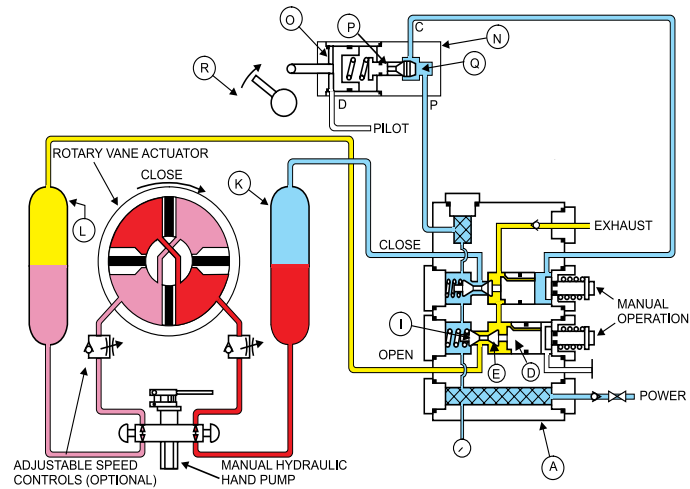
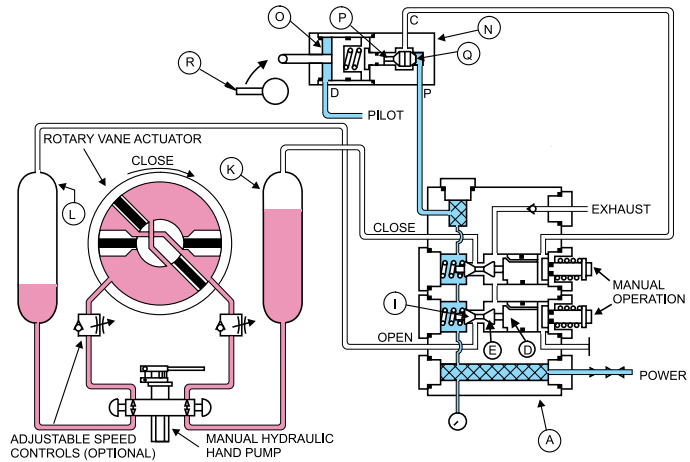

[www.emerson.com/shafer](http://www.emerson.com/shafer)

Emerson  
19200 Northwest Freeway  
Houston TX 77065  
USA  
T +1 281 477 4100  
F +1 281 477 2809

[info.actuationtechnologies@emerson.com](mailto:info.actuationtechnologies@emerson.com)

- Exhaust Gas
- High Pressure Gas
- Non-Pressurized Hydraulic Fluid
- Pressurized Hydraulic Fluid

**SHAFER**

Bulletin ESD-06-17