

Data sheet

Sheet No.: 1.103.103 Rev. A

Date: November 2009

DIMENSION SHEET ACTUATOR DIN E12 (90°/180°)

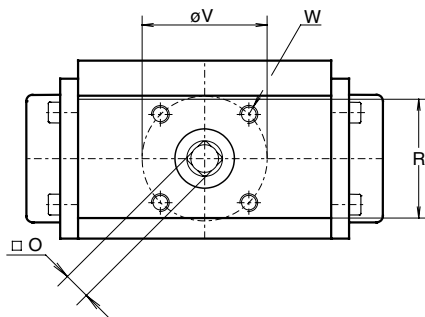
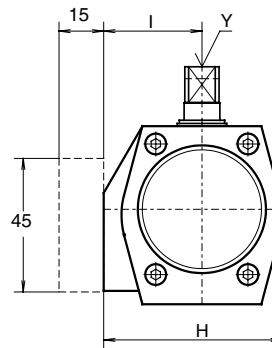
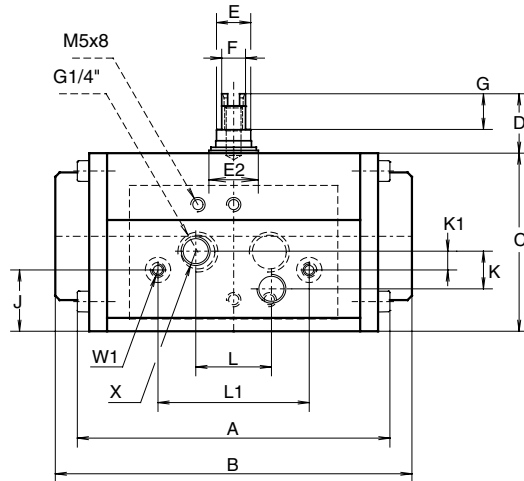
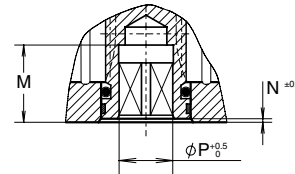
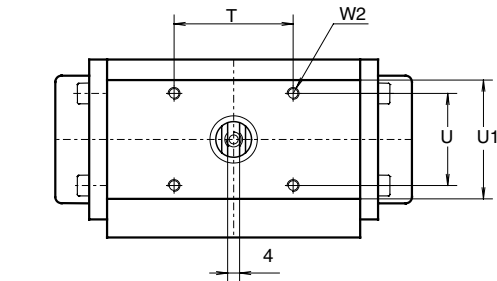

Dim. in mm	90°	180°
A ED	103	155
B ES	118	216
C	60	60
D	20	20
E	16	16
E2	23	23
F	10	10
G	12	12
H	60	60
I	33	33
J	21	21
K	12.7	12.7
K1	6.4	6.4
L	25.4	25.4
L1	50.8	50.8
M	16.5	16.5
N	1	1
O max.	9.1	9.1
O min.	9	9
P	12.1	12.1
R	40	40
R1	40	40
T	40	40
U	31	31
V	42	42
W	M6x8	M6x8
W1	M4x7	M4x7
W2	M4x7	M4x7
X	G1/8"	G1/8"
Y	M6x12	M6x12

DOUBLE ACTING TORQUE (ED)

Pressure	bar	3.5	4	4.5	5	5.5	6	7
Torque 90°/180°	Nm	8.5	9.7	10.9	12.2	13.4	14.6	17.1

SINGLE ACTING TORQUE (ES)

Pressure	bar	Air stroke				Spring stroke	
		5		6		start	end
Position	-	start	end	start	end		
Torque 90°	Nm	7.6	4.9	10	7.5	7.2	4.6
Torque 180°	Nm	7.8	5	10.4	7.6	7.1	4.5

Note: Dotted image represents optional NAMUR solenoid interface block



www.El-O-matic.com

Copyright © Emerson Process Management. The information in this document is subject to change without notice.

Updated data sheets can be obtained from our website www.El-O-matic.com or from your nearest Valve Automation Center **USA:** +1 813 319 0266 **Europe:** +31 74 256 10 10 **Asia-Pacific:** +65 6501 4600



EMERSON
Process Management