

Data sheet

Sheet No.: 1.501.03 Rev. A

Date: November 2009

LIMIT STOP PLATE DIMENSIONS

LS 420

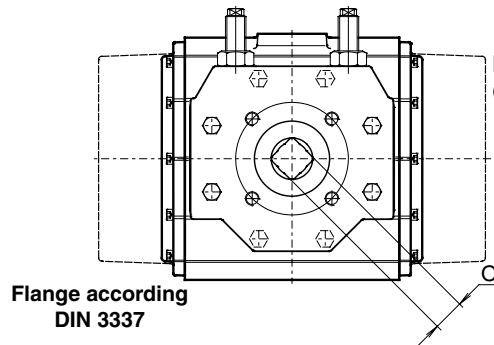
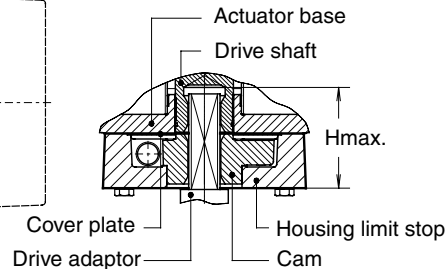
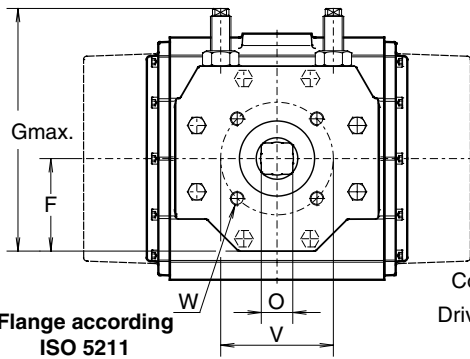
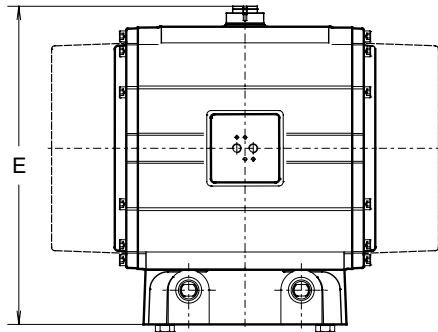

Note:
Cover plate only in combination with P2500

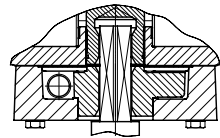

Description

These limit stop plates are used when precise control is required for both end of stroke positions. It is possible to adjust 15° of both ends of the standard stroke.

Construction

The complete stop plate assembly may be added to the 90° P-series actuators. The assembly is normally sandwiched between the actuator and mounting surface of the valve or bracket. Bearing rings are used at both surfaces to provide a long life expectancy.

The unit is assembled with a drive adaptor which passes through the stop plate, into the square actuator and provides the coupling between the two components. This drive adaptor normally also accommodates the coupling of the valve stem.

Identification

"LS420" is added to the basic part number i.e. PD2500-LS420

Other dimensions

See data sheet 1.103.xxx

Option

Version for 180° or DIN-standard actuator

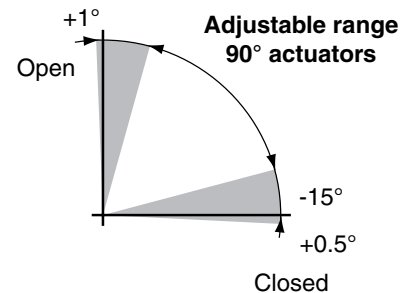

Dim. in mm.	ACTUATOR TYPE	
	P2500	P4000
E	466	490
F	135	135
G	322	322
H	130	141
O	46	55
V	165	165
W	M20x30	M20x30

EL-O-MATIC

www.El-O-matic.com

Copyright © Emerson Process Management. The information in this document is subject to change without notice.

Updated data sheets can be obtained from our website www.El-O-matic.com or from your nearest Valve Automation Center **USA:** +1 813 319 0266 **Europe:** +31 74 256 10 10 **Asia-Pacific:** +65 6501 4600



EMERSON
Process Management