

**Mod L20: Installation Procedure**  
**HP/DHV/L/INST**  
05-04-11

# **Shafer Hand Pump – Double Holding Valve**

## Installation Procedure on a Linear Actuator

## Mod L20: Installation Procedure

HP/DHV/L/INST

05-04-11

The purpose of this procedure is to guide the installation of a Shafer Hand Pump – Double Holding Valve to an existing Linear Actuator.

This procedure is to be used in conjunction with the following Maintenance and Service Manual.

Shafer Hand Pump – Double Holding Valve	Bulletin HP/DHV
---	-----------------

**NOTE:** With pressure in the pipeline, installation should be done with the valve in the OPEN position. With no pressure in the pipeline, installation should be done with the valve in the CLOSE position.

**WARNING:** 1. Turn power gas off (bleed down the power storage tank if applicable).  
2. Drain oil out of the gas hydraulic tanks.



1. Remove tubing from latches to hand pump.
2. Remove latches from gas hydraulic tanks.
3. Remove tubing from hand pump to actuator.

**NOTE:** If the actuator is in the open position you will get oil draining from the lower connection. All the oil will drain from under the piston.

4. Remove the old hand pump.
5. Install the new universal hand pump mounting bracket using the mounting holes for the old hand pump.
6. Install the new hand pump - double holding valve on the mounting bracket.

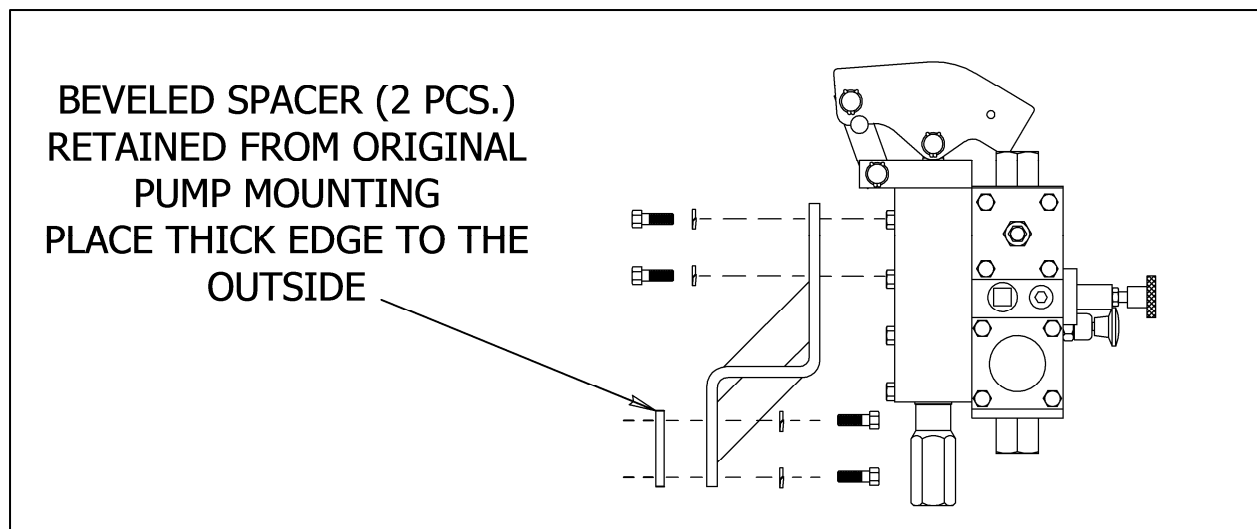
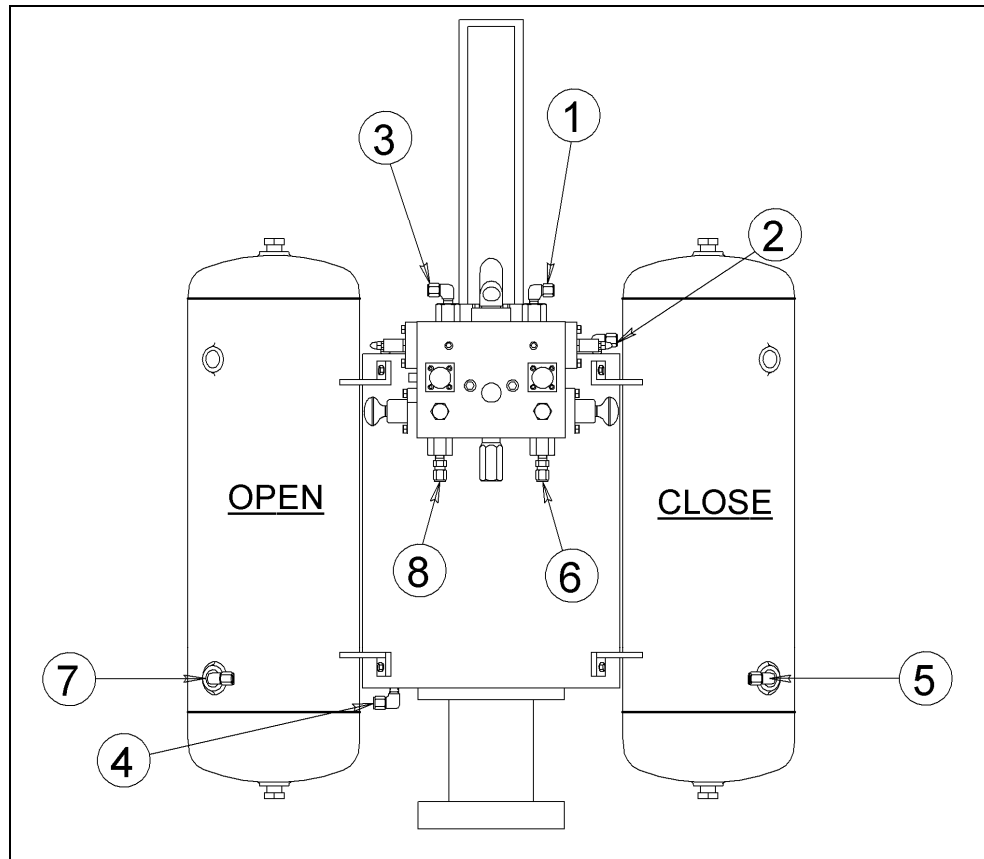

Figure 1: Universal Pump Bracket and Hand Pump

## Mod L20: Installation Procedure

HP/DHV/L/INST

05-04-11



**Figure 2: Front View With Pump-Double Holding Valve**

7. Install Swagelok<sup>®</sup> fitting in the hand pump, actuator and tanks.
8. Run tubing from the lower ports in the gas hydraulic tanks (7 & 5) to the suction ports located at the bottom of the hand pump (8 & 6). Right tank (close) to the right suction port and the left tank (open) to the left suction port.
9. Run tubing from the discharge ports located on top of the hand pump (3 & 1). The right side of the pump runs to the upper head of the actuator (2). The left side of the pump runs to the lower head of the actuator (4).
10. Fill both of the gas hydraulic tanks to within two inches of the upper weld ring.

**Note:** The reason both tanks are filled is that the actuator has no oil in it, if it is in the open position. But, if the actuator is in the close position just fill the open tank to within two inch of the upper weld ring and the close tank to the lower weld ring. Use the hand pump to close or open the actuator to purge the actuator and hydraulic lines.

11. Use the hand pump to close or open the actuator to purge the actuator and hydraulic lines.
12. Turn power gas on.
13. Stroke the actuator in both directions using power gas pressure.
14. Leave the actuator in the desired position.

## Mod L20: Installation Procedure

HP/DHV/L/INST

05-04-11

---

If any further information is required, please feel free to contact:

Emerson Process Management  
Valve Automation Inc.  
2500 Park Avenue West  
Mansfield, Ohio 44906

Phone: (419) 529-4311

Fax (419) 529-3688

Please visit our website for up to date product data. [www.shafervalve.com](http://www.shafervalve.com)

### All Rights Reserved

The contents of this publication are presented for informational purpose only, and while every effort has been made to ensure their accuracy, they are not to be construed as warranties or guarantees, express or implied, regarding the products or services described herein or their use or applicability. We reserve the right to modify or improve the designs or specifications of such products at any time with out notice.

Trademarks owned by other companies that are referred to in our product literature include: Swagelok®