

Performance Specifications ATB Series (A-Type, Medium Thrust)

Multi-turn Bevel Gear Operators for Manual Operation and Electrical Actuation

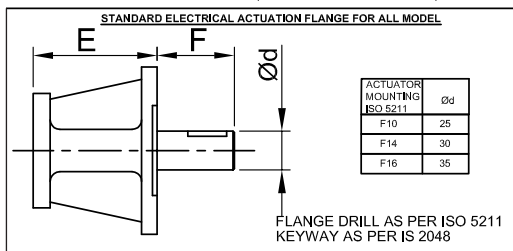
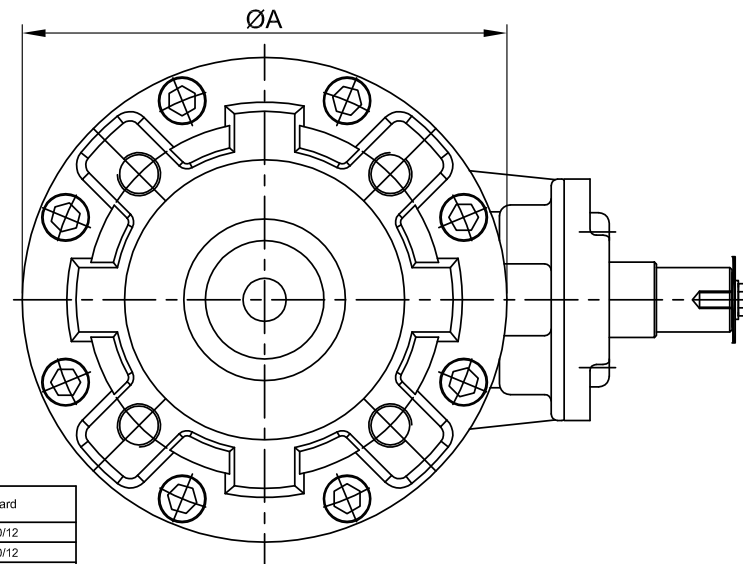
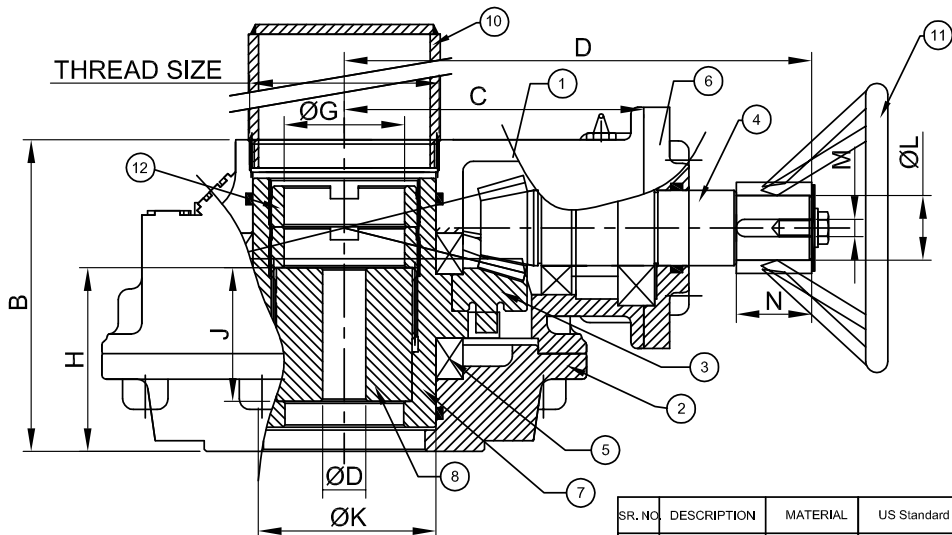

| SR. NO. | DESCRIPTION | MATERIAL | US Standard | IS Standard |
|---------|------------------|---------------|----------------------------|----------------------|
| 1 | Housing | Ductile Iron | ASTM A536 65-45-12 | SGI 400/12 |
| 2 | Base Plate | Ductile Iron | ASTM A536 65-45-12 | SGI 400/12 |
| 3 | Bevel Gear | Carbon Steel | ASTM A322 4140 | 40Cr4Mo3 |
| 4 | Bevel Pinion | Carbon Steel | ASTM A322 4140 | 40Cr4Mo3 |
| 5 | Thrust Bearing | Special Steel | Cylindrical Roller Bearing | |
| 6 | Flange Cap | Ductile Iron | ASTM A536 65-45-12 | SGI 400/12 |
| 7 | Adaptor Sleeve | Ductile Iron | ASTM A536 70-50-05 | SGI 500/7 |
| 8 | Adaptor | Bronze | B148 C95800 | - |
| 9 | Hardware | Carbon Steel | - | 10.9Gr or Equivalent |
| 10 | Stem Protector | Carbon Steel | ASTM A53 | IS 2062 Gr B |
| 11 | Handwheel (Pipe) | Carbon Steel | ASTM A53 | IS 2062 Gr B |
| 12 | Lock Nut | Carbon Steel | ASTM A576 1045 | 45C8 |

| MODEL | RATIO | RATED OUTPUT TORQUE (Nm) | MECHANICAL ADVANTAGE | INPUT TORQUE (Nm) | VALVE MTG FLANGE ISO 5211 | OPTIONAL VALVE MTG FLANGE ISO 5211 | MAX STEM DIAMETER/ØD | MAX THRUST (KN) | A | B | C | D | E | F | ØG | H | J | ØK | ØL | M | N | RECOMMENDED HANDWHEEL | APPROX WEIGHT (Kg) | THREAD SIZE |
|----------|--------|--------------------------|----------------------|-------------------|---------------------------|------------------------------------|----------------------|-----------------|-----|-----|-----|-----|----|----|-----|-------|-------|-------|-----|----|----|-----------------------|--------------------|------------------|
| ATB-01M | 1:1 | 150 | 0.9 | 166 | F07/F10 | - | 25 | 130 | 135 | 105 | 88 | 172 | 66 | 58 | 27 | 49 | 40 | 33 | Ø25 | 8 | 35 | Ø300 | 10 | 1 3/4"X11TPI BSP |
| ATB-02M | 2.5:1 | 250 | 2.25 | 111 | F10/F12 | - | 30 | 205 | 150 | 110 | 100 | 185 | 66 | 58 | 32 | 60.5 | 43 | 37.5 | Ø25 | 8 | 35 | Ø300 | 12 | 2"X11TPI BSP |
| ATB-03M | 3:1 | 400 | 2.7 | 148 | F10/F12 | F14 | 40 | 250 | 169 | 113 | 110 | 201 | 66 | 58 | 42 | 64.5 | 48 | 45.5 | Ø30 | 8 | 35 | Ø400 | 13 | 2"X11TPI BSP |
| ATB-06M | 3.25:1 | 600 | 2.92 | 205 | F12/F14 | F16 | 50 | 290 | 193 | 122 | 108 | 187 | 66 | 58 | 47 | 72.5 | 56 | 53 | Ø30 | 8 | 35 | Ø500 | 15 | 2.5"X11TPI BSP |
| ATB-11M | 4:1 | 1100 | 3.6 | 305 | F14/F16 | - | 55 | 415 | 228 | 145 | 141 | 217 | 66 | 58 | 56 | 85.5 | 62 | 63 | Ø30 | 8 | 35 | Ø600 | 24 | 3"X11TPI BSP |
| ATB-16M | 4.5:1 | 1600 | 4.05 | 395 | F16/F20 | F25 | 68 | 630 | 275 | 168 | 166 | 254 | 66 | 58 | 75 | 106.5 | 77.5 | 87.5 | Ø30 | 8 | 35 | Ø600 | 34 | 3.5"X11TPI BSP |
| ATB-23M | 5:1 | 2500 | 4.5 | 556 | F20/F25 | F30 | 82 | 680 | 335 | 174 | 193 | 281 | 66 | 58 | 85 | 109.5 | 83.5 | 93.5 | Ø30 | 8 | 35 | Ø600 | 50 | 4"X11TPI BSP |
| ATB-38M | 5.5:1 | 3800 | 4.95 | 768 | F25/F30 | F35 | 95 | 780 | 376 | 202 | 220 | 323 | 66 | 58 | 90 | 135.5 | 100 | 101 | Ø38 | 10 | 35 | Ø600 | 84 | 5"X11TPI BSP |
| ATB-55M | 6:1 | 5500 | 5.4 | 1018 | F30/F35 | F40 | 105 | 965 | 432 | 235 | 246 | 352 | 70 | 60 | 111 | 153.5 | 105 | 125 | Ø38 | 10 | 35 | Ø750 | 155 | 5"X11TPI BSP |
| ATB-85M | 6.5:1 | 8500 | 5.85 | 1452 | F35/F40 | - | 125 | 1270 | 490 | 259 | 267 | 372 | 70 | 60 | 126 | 165.5 | 110 | 141 | Ø38 | 10 | 35 | Ø750 | 185 | 6"X11TPI BSP |
| ATB-130M | 7:1 | 13000 | 6.3 | 2063 | F35/F40 | - | 145 | 1700 | 590 | 290 | 340 | 468 | 70 | 60 | 150 | 189 | 141.5 | 177.5 | Ø50 | 14 | 50 | Ø750 | 280 | M218X3P |
| ATB-180M | 8:1 | 18000 | 7.2 | 2500 | F40 | F48 | 170 | 2600 | 680 | 323 | 390 | 512 | 70 | 60 | 180 | 199.5 | 150 | 197.5 | Ø50 | 14 | 50 | Ø750 | 360 | M218X3P |