

# C1415 Controller Board Setup and Operating Instructions

# BETTIS™

Actuator Models: All  
Bulletin: C1415-05/06

This bulletin provides installation and operating information for the Bettis Controller Board C1415. Should you have any questions about the controller that are not covered under this bulletin, please contact an authorized Bettis Valve Automation Center or Bettis Electric Division, Mansfield, Ohio U.S.A.

## General Description

The Bettis C1415 DC Motor Controller board is an accurate, easy to use, multi-function servo-board, intended for use with brush type motors. No calibration equipment is required to set the board. The basic concept of this controller is to read an external command signal and compare it to a feedback signal from a potentiometer linked to the output shaft. When the signals are not equal, the controller will energize either the clockwise or counterclockwise motor circuit. This drives the actuator in the direction that reduces the signal difference. Once the signals are equal, the controller opens the motor circuit and the actuator is positioned properly, awaiting the next external command signal change.

The controller has the following options:

- Input power: 12 Vdc or 24 Vdc
- Input signals: 4-20 mA, 0-10 Vdc, 1-5 Vdc, or external command potentiometer
- Output signal: 4-20 mA
- Loss of command signal: fail in place, fail CCW, fail CW
- Acting: direct acting (i.e. CW at 4 mA), reverse acting (i.e. CCW at 4 mA)
- Torque trip sensitivity: Variable, range dependent on actuator torque rating
- Motor restart delay: Variable from one to thirty-two seconds
- Command sensitivity (deadband): Variable, range depends on command signal

## Wiring

There are four terminal blocks on the controller board, designated as TB1, TB2, TB3 and TB4. Terminal block TB1 is a 3 pole terminal block and is used for the (-) Vdc power termination along with the external trip reset terminations. Terminal block TB2 is a 9 pole terminal block and is used for all incoming and outgoing control signals. Terminal block TB3 is a 5 pole terminal block used for limit switch terminations along with internal trip indication output terminations. Terminal block TB4 is used for the (+) Vdc power termination along with limit switch and motor terminations.

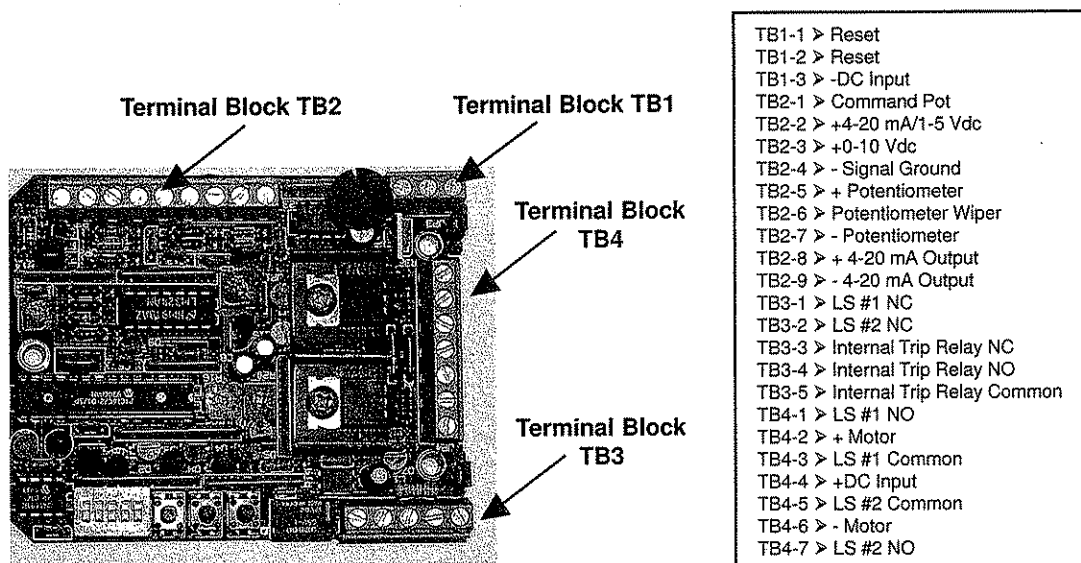

### Jumpers

There are four jumpers on the controller board designated as JP1, JP2, JP3 and JP4. JP1 provides the option for a 4-20 mA or 0-10 Vdc command signal input. JP2 is a sensitivity jumper for the boards internal calculation. JP3 and JP4 provide the option for 12 Vdc or 24 Vdc voltage inputs. See below for jumper configurations.

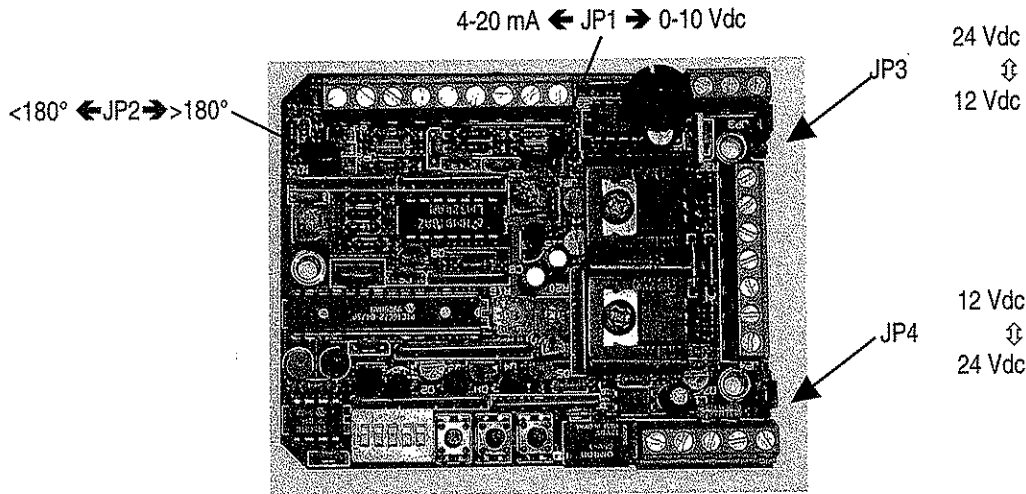

### Output Indicators

There are two LEDs for visual reference during board operation. The red LED is lit as the controller sends a signal to the motor to turn the actuator CCW or OPEN. The green LED is lit as the controller sends a signal to the motor to turn the actuator CW or CLOSED. The green LED is also a programming LED that is lit each time a setting is saved in memory. See below for LED layout.

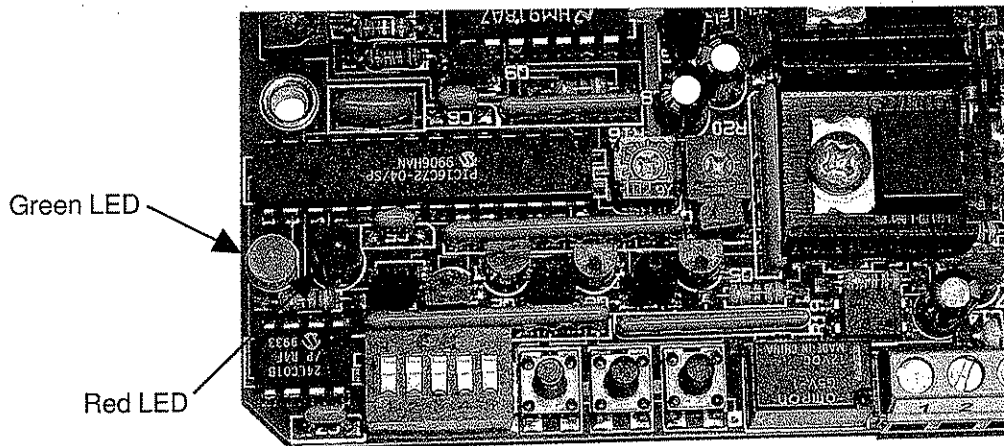

### Dip Switches

There are five dip switches that are used to calibrate the controller. Configuration of these dip switches set the actuator and its functions.

### Push Buttons

There are three push buttons on the controller board, PB1, PB2, and PB3. PB1 (black) operates the actuator in the CCW position when the controller is in the calibration mode. PB2 (black) operates the actuator in the CW position when the controller is in the calibration mode. PB3 (red) is depressed each time a setting is required to be saved into memory. See below for push button layout.

### Calibration Potentiometer

There are two potentiometers used to calibrate the Motor Restart Delay, Sensitivity, and Torque Trip. Once the potentiometer positions are stored in memory via the program push button, it can be moved without changing any of the settings. Thus allowing each potentiometer to be used for multiple settings. The potentiometers are located below.

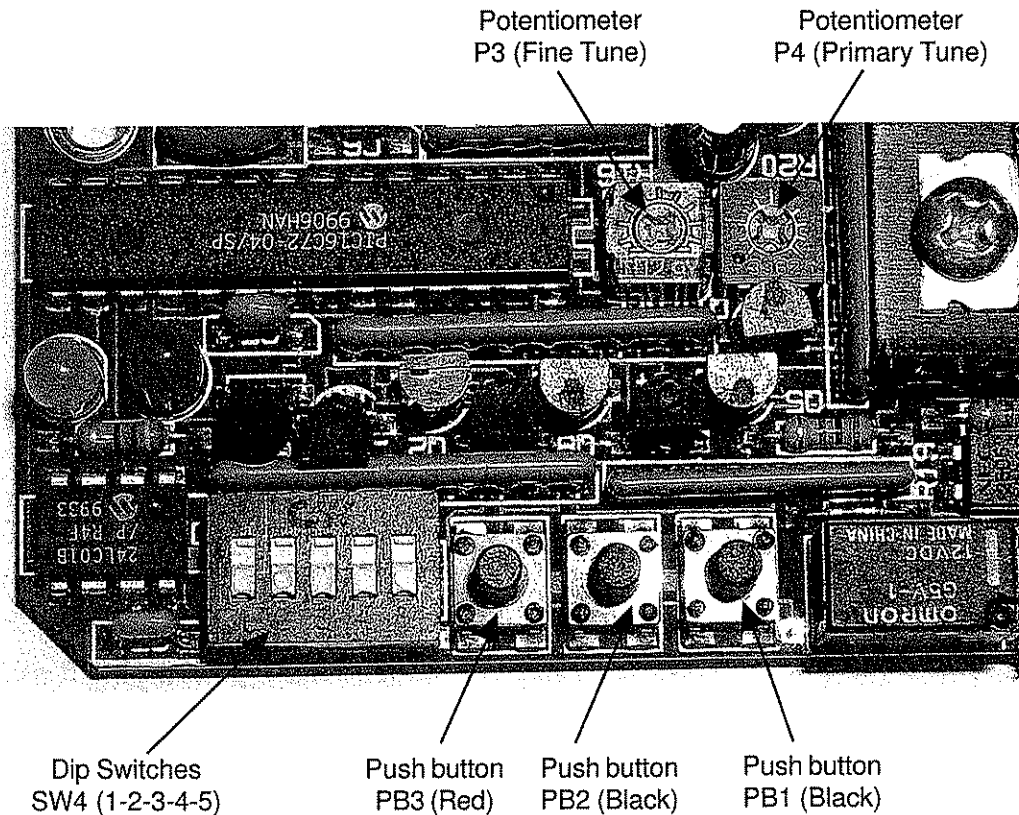

---

## Standard Setup and Operation

***Please note that the following installation instructions must be followed in strict accordance with the order outlined below.***

1. Verify controller board is wired up properly per the wiring diagram supplied with the actuator.
2. Do not connect any command signals to the actuator at this time.
3. Verify all jumpers are set properly for your application. DO NOT change any jumpers while the power is on. This may cause damage to the controller.
4. Switch dip switch #1 to the "ON" position and dip switches #2 through #5 to the "OFF" position. This sets the controller for calibration mode.
5. Turn on the power to the actuator.
6. The next three series of steps will complete the basic setup of the controller. This entails calibrating the potentiometer to the position of the output shaft along with programming the end of travel setpoints into the controller.
7. ***This step is for field installed kits only. Omit for factory installed boards!***  
To set the potentiometer, perform the following steps in order
  - a) Loosen the set screw in the potentiometer gear located on the output shaft.
  - b) Using PB1 and/or PB2, position the actuator halfway between the end of travel limits.
  - c) Switch both dip switches #4 and #5 to the "ON" position.
  - d) Rotate the potentiometer shaft gear until the red and green LEDs are illuminated.
  - e) Engage the potentiometer and output shaft gear teeth and tighten the gear set screws.
  - f) Switch both dip switches #4 and #5 to the "OFF" position.
8. To set the end of travel CCW limit, perform the following steps in order
  - a) Using PB1, position the actuator to the CCW end of travel limit.
  - b) Switch dip switch #2 to the "ON" position.
  - c) Push PB3 to save this position in memory and verify green light flashes once.
  - d) Using PB1, position the actuator to approximately 1° past the CCW end of travel limit and set the bottom cam.
9. To set the end of travel CW limit, perform the following steps in order.
  - a) Using PB2, position the actuator to the CW end of travel limit.
  - b) Switch dip switch #2 to the "OFF" position.
  - c) Push PB3 to save this position in memory and verify green light flashes once.
  - d) Using PB2, position the actuator to approximately 1° past the CW end of travel limit and set the second cam up.
10. Switch dip switch #1 to the "OFF" position.

**At this time, the controller is set for basic operation. The actuator is ready to be operated upon connection of an external command signal.**

**Additional Control****Loss of Command Signal Setting (4-20 mA or 1-5 Vdc operation only)**

This command works only in the "RUN" mode, i.e. when dip switch #1 is in the "OFF" position. The board can be set to transfer to the CW limit or CCW limit upon loss of the command signal. This is defined by dip switches #4 and #5.

- 1) To move the actuator to the lowest setting (i.e. 4 mA position) upon loss of signal, set both dip switches #4 and #5 to off.
- 2) To let the actuator fail in place upon signal loss, set both dip switches #4 and #5 to on.
- 3) To move the actuator to the CCW limit upon loss of signal, set dip switch #4 to on and dip switch #5 to off.
- 4) To move the actuator to the CW limit upon loss of signal, set dip switch #4 to off and dip switch #5 to on.

**Direct/Reverse Acting**

This command works only in the "RUN" mode, i.e. when dip switch #1 is in the "OFF" position. Under normal, or direct operation, the actuator moves CW when the command signal is decreased and CCW when the command signal is increased. This can be reversed by placing dip switch #3 to the on position. Thus a 4mA or 0Vdc signal would move the actuator to the CCW end of travel and 20mA or 10Vdc would move CW.

**Motor Restart Delay**

This delay can be used to smooth out or damp the response of the modulated device in a system that provides multiple command signals over a short period of time. This delay occurs when the system issues a signal which requires the actuator to reverse direction. A delay also occurs if the actuator reaches the proper position, and then receives a signal requiring it to operate again within the delay time. The delay can be set from 1 second (factory setting) to 32 seconds. To change the delay, perform the following steps in order.

- 1) Set dip switches #1 and #3 only to the on position.
- 2) Apply power to the controller.
- 3) Adjust potentiometer P4 fully CCW. Next, adjust P3 for the desired delay. Fully CCW is 1 second, fully CW is 32 seconds (the potentiometer is linear).
- 4) Push PB3 to save this position in memory.
- 5) Turn off the power to the controller.
- 6) Return dip switches #1 and #3 to the off position.

**Command Sensitivity**

This option is similar to that of deadband control. To change the sensitivity of the controller with respect to the necessary change in magnitude of the command signal, perform the following steps in order.

- 1) Set dip switches #1 and #4 only to the on position.
- 2) Apply power to the controller.
- 3) Adjust potentiometer P4 fully CCW. Adjust P3 for the desired sensitivity. Fully CCW is maximum sensitivity while fully CW is minimum sensitivity.
- 4) Push PB3 to save this position in memory.
- 5) Turn off the power to the controller.
- 6) Return dip switches #1 and #4 to the off position.

### 4-20 mA Output

A 4-20 mA output can be for remote indication of the actuators position. This signal is provided across terminals 8 and 9 of terminal block TB2 of the controller.

### Torque Trip Sensitivity

To calibrate the torque trip, set SW4-2, SW4-3, and SW4-4 to the off position. SW4-1 and SW4-5 should be in the on position. Apply power to the board. Adjust the servoboard potentiometer P3 (yellow dial) to its mid position. Adjust potentiometer P4 to set the torque trip level. Once P4 is set, P3 can be adjusted for fine tuning. Depress push button PB3 to store the setting in memory. The green LED should light indicating a successful save.

### To Utilize The Command Switch

When it is desirable to use the C1415 Motor Controller board for torque limiting service and a command signal is not provided, the following setup instructions must be followed. Supplying a remote switch and programming the board in this manner will allow directional control where the actuator will move in either the ccw or cw direction depending upon the position of your switch. The switch may have a center-off position which will make it possible to stop the actuator between the full limits of travel.

Before using the C1415 with a remote switch, the first step is to calibrate the fully ccw/cw positions. First, set the potentiometer per section 7 on page 4. Next, remove all command signals and connect a jumper between TB2-6 and TB2-7. Turn on Dip Switch #1 and program the CW limit per section 8 on page 4. Next install the jumper between TB2-6 and TB2-5. Turn on Dip Switch #2 and program the CCW limit per section 9 on page 4. Connect two 1 kohm resistors to TB2-5, -6, -7 as shown in Figure 1 and Figure 2.

If the remote switch does not have a center-off position, wire the command input as show in Figure 1. In addition, put JP1 in the 0-10V position and set SW4-4 and SW4-5 to the off position.

If the remote switch does have a center-off position, wire the command input as shown in Figure 2. Connect a 3.0 kohm resistor across the remote switch as shown in Figure 2. In addition, connect a 1 kohm resistor between TB2-2 and TB2-4. Completely remove the jumper at JP1 and set SW4-4 as well as SW4-5 to the on position (activating the Fail-in-Place mode). When the remote switch is in the off position, the actuator will stop in place.

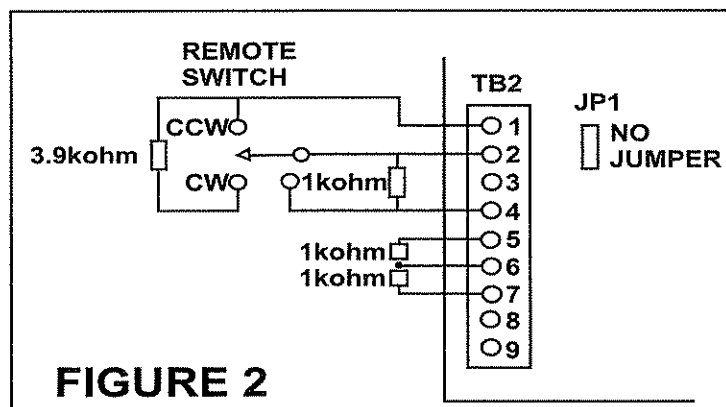
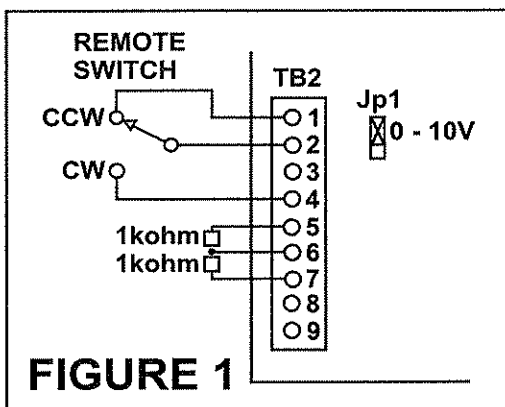

**Specifications****DC Power**

- 12 Vdc or 24 Vdc  $\pm$  10%. Jumper configurable.

**Signal Inputs [digitized to 8 bit (1 in 255) accuracy]**

- 0-10 Vdc command input, 200 Kohm input impedance.
- Command potentiometer input, 5 Vdc excitation voltage, 100 Kohm input impedance, use with 1 Kohm potentiometer.
- 1-5 Vdc command input, 100 Kohm input impedance, Loss of signal threshold is 75% of low signal.
- 4-20 mA command input, 250 ohm input impedance, Loss of signal threshold is 75% of low signal.
- Feedback input, 5 Vdc excitation voltage, 1 Mohm input impedance, used with 1 Kohm potentiometer.

**Signal Output [8 bit (1 in 255) accuracy]**

- 4 to 20 mA, 300 ohm maximum load impedance.

**DC Motor Outputs**

- Maximum locked rotor load current of 5 A and continuous current rating of 3 A.

**External Fuses**

The DC power supply should have overcurrent protection tailored to the demands of the actuator motor used. The rating of the fuse or circuit breaker must not exceed 5 A.

**Environmental**

- Operating temperature: 0°C to 70°C.
- Storage temperature: -40°C to 85°C.
- Relative humidity: 0 to 90% non-condensing.

## Troubleshooting

The board does not operate when the open and close buttons are depressed.

- Verify main power to the controller is on.
- Verify the output shaft cams are engaging the limit switch toggle arms.
- Verify Dip Switch #1 is in the "calibrate" or "ON" position.

The green or red light on the board is lit, but the actuator has stopped.

- Verify that the output shaft cams are about 1° outside the programmed end of travel setpoints of the controller.

The green LED is flashing with a shorter time on than off after the controller has been set.

- Reset the CW and CCW end of travel limits with the 4-20 mA or 0-10 Vdc signal generator wired up. The signal generator should be set on 4 mA or 0 Vdc for the CW limit and 20 mA or 10 Vdc for the CCW limit. These settings would be opposite for reverse acting applications.

The green LED is flashing with a shorter time off than on after the controller has been set.

- Reset the CW and CCW end of travel limits with the 4-20 mA or 0-10 Vdc signal generator wired up. The signal generator should be set on 4 mA or 0 Vdc for the CW limit and 20 mA or 10 Vdc for the CCW limit. These settings would be opposite for reverse acting applications.

The controller drives the actuator to the fully OPEN or CLOSED position without response to the command signal.

- The feedback potentiometer may be wired backward. Verify the potentiometer is connected to the proper terminals as shown on page 1.

The controller output appears erratic, sometimes moving in the wrong direction.

- The feedback potentiometer may be "wrapping around". Verify the potentiometer has been centered correctly.
- Calibration may not have been programmed properly. Recalibrate the CCW and CW limits.

Should you have any questions, please feel free to contact our application engineers at 419-529-4296.