

Controls Southeast, Inc. ControHeat Jackets for Micro Motion[®] Sensors

Contents

ControHeat Jacket Overview	page 1
Step 1: Installing a ControHeat Jacket	page 3
Step 2: Installing the Heating Medium Jumpovers	page 5
Step 3: Attaching a ControCover Insulation Blanket.	page 7
Removing a ControHeat Jacket	page 8
Contacting Controls Southeast, Inc.	page 8

ControHeat Jacket Overview

Product overview

ControHeat jackets are aluminum castings produced for specific models and sizes of Micro Motion sensors that are installed in processes that operate at elevated temperatures. Although most process lines are insulated, heat loss can be substantial. A heating device, or jacket, is necessary to compensate for the heat loss. A steel pressure chamber is cast into each ControHeat jacket. The heating medium flows through this chamber to rapidly heat the aluminum and transfer the heat to the sensor. The ControHeat jackets snugly fit the sensor and allow for bolting clearance at the back of the sensor flanges and power/signal connections to the sensor.

Figure 1 illustrates the different types and sizes of ControHeat jackets. The figure shows an example of a two-piece ControHeat jacket for smaller sensors and an example of a multi-segmented ControHeat jacket for larger sensors.

Figure 1 Examples of a ControHeat jacket sized for different Micro Motion sensors

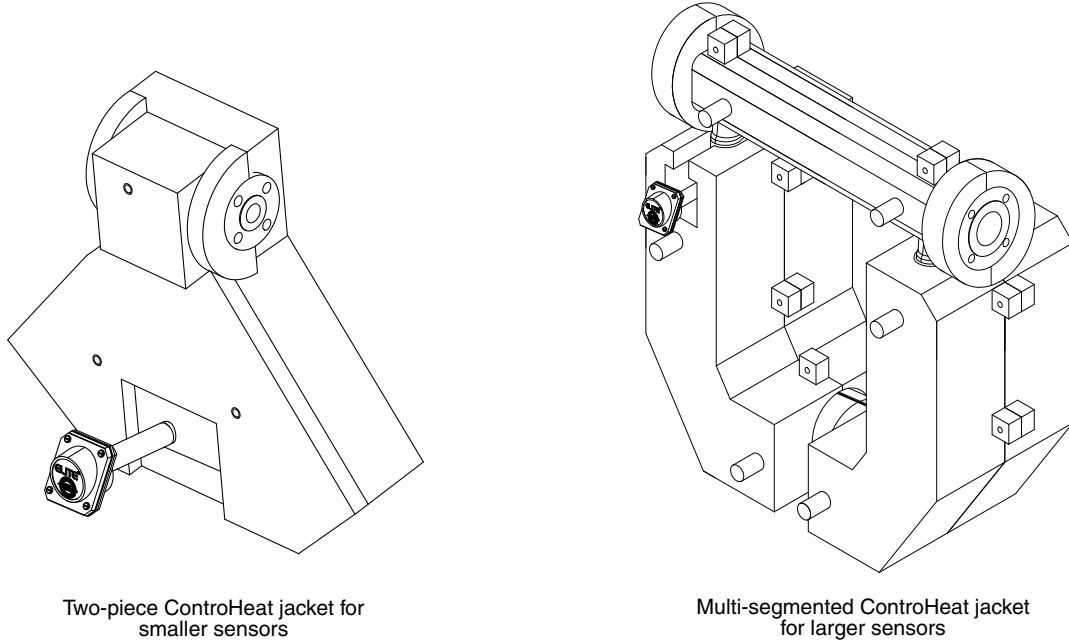

Lifting requirements

Because the ControHeat jackets are sized for specific models and sizes of Micro Motion sensors, some jackets can be heavy to lift and may require the following:

- Two people to lift and attach the jacket segments to the installed sensor
- OR*
- A lifting crane to lift and attach the jacket segments to the installed sensor.

To determine the lifting requirements, refer to the shipping information that accompanied the ControHeat jacket and Micro Motion sensor. Also, refer to the lifting and mounting information in the user manual that shipped with the Micro Motion sensor.



Some of the larger ControHeat jackets include lifting eyes to transport and mount the jacket to the Micro Motion sensor after the sensor has been installed in the process line. These lifting eyes are not for hanging or supporting the sensor. You should only use them to assist in lifting and installing the ControHeat jacket to the Micro Motion sensor.

Step 1: Installing a ControHeat Jacket

Before you begin

Before you install the ControHeat jacket on the Micro Motion sensor, you must install the Micro Motion sensor into its proper position in the process line. See the sensor installation manual that shipped with the Micro Motion sensor. Document the information listed on the sensor tag, such as the serial number and calibration data, elsewhere and make this information accessible near the sensor. Once you install the heat jacket, you can no longer access the sensor tag that shows this information.



Always use the extended-mount junction box or the extended-mount electronics option that is available with the Micro Motion sensor when using a ControHeat jacket. The extended-mount installation ensures the electronics and wiring connections are outside of the insulated area, so that they do not exceed the ambient temperature specification of the Micro Motion sensor.

Tools required

You need the following tools to install a ControHeat jacket:

- Two wrenches (open end, adjustable, or socket type)
- Screwdriver
- Heavy-duty aluminum foil (if applicable)
- Heat-transfer cement
- Suitable mason's trowel
- Damp paper towels or rags
- Lifting crane (if applicable)

Procedure

1. Verify that the Micro Motion sensor has been installed correctly and according to the safety requirements for the sensor.
2. Verify the appropriate information listed on the sensor tag, such as the serial number and calibration data, has been documented elsewhere and made accessible near the sensor.
3. Visually inspect the Micro Motion sensor and remove any foreign material – such as debris or packaging – from the surface of the Micro Motion sensor.
4. Dry fit the jacket segments to the sensor body to verify the ControHeat jacket fits properly to the sensor. To “dry fit” means to fit the segments to the sensor before applying the heat-transfer cement. To do this:
 - a. Using a wrench and/or screwdriver, remove the fasteners that hold the jacket segments together.
 - b. Place both segments around the sensor.

Note: Normally there is a slight clearance between the inner jacket surface and Micro Motion sensor. If there is a problem that prevents the jacket segments from mating, contact Micro Motion.

5. Remove the jacket segments from the sensor and lay the segments on a clean, dry work area with the inner surfaces facing up.
6. If you expect to remove and reinstall the heat jacket to the sensor frequently, line the Micro Motion sensor with heavy-duty aluminum foil (optional). Mold the foil to the shape of the sensor.

7. Using the mason's trowel, coat the inner surfaces of the jacket segments with heat-transfer cement. Also, apply a small amount of heat-transfer cement to the backs of the sensor flanges at three or four places. The coating should be approximately 3-6 mm thick. The application of heat-transfer cement ensures that air gaps between the jacket and sensor have been filled.
8. Using the appropriate lifting device, place the coated jacket segments around the Micro Motion sensor and press firmly into place. If you are installing a multi-segmented jacket, install the jacket segments from lower elevation to higher elevation.

Figure 2 Placement of a ControHeat jacket sized for smaller or larger Micro Motion sensors

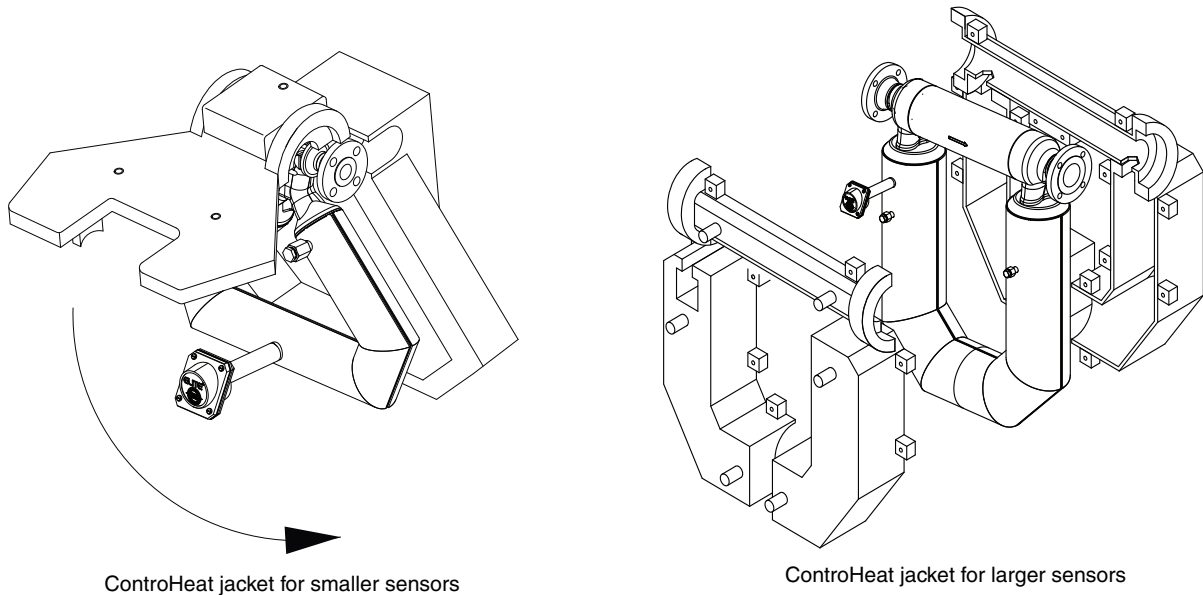

9. Using the wrenches, bolt the jacket pieces together with the fasteners provided.
10. Tighten the fasteners, alternating between the fasteners before fully tightening each. This process ensures a snug, even seating of the jacket segments on the sensor. Excess heat-transfer cement will extrude from the jacket edges and the flange interfaces.
11. Remove the excess heat-transfer cement with the trowel. Use damp paper towels or rags to clean any remaining cement from the installation. Ensure that no heat-transfer cement is on the jacket coupling threads.



After the installation of the ControHeat jacket, allow the heat-transfer cement to cure at ambient temperature [above 0 °C (32 °F)] for 24 hours before the heating medium is turned on. If you need to accelerate the curing time, you can apply the heating medium intermittently for short intervals (5 minutes). You must not exceed a temperature of 100 °C (212 °F) during the curing cycle.

Step 2: Installing the Heating Medium Jumpovers



You assume the responsibility to understand the criteria for making the connections from the ControHeat jacket to the heating medium pipeline based on the heating medium applied. However, for additional technical assistance in making the jumper connections, contact Controls Southeast, Inc. or Micro Motion.

Product overview

The following information describes the recommended installation for the heating medium jumpovers. The jumpovers are used to connect the ControHeat jacket to the heating medium. When connecting the jacket to the heating medium, you are required to make two connections to the pipeline: one to allow the heating medium to flow into the jacket; and, another to allow the heating medium to flow out of the jacket. Depending on the type of jacket you have installed, you may be required to install one or more jumpovers to connect each jacket segment.

Figure 3 illustrates one example of a jumper and identifies the jumper components. The jumper end fittings and lengths vary depending on the design criteria of the jumper and the ControHeat jacket.

Figure 3 Cross-section view of a heating medium jumper

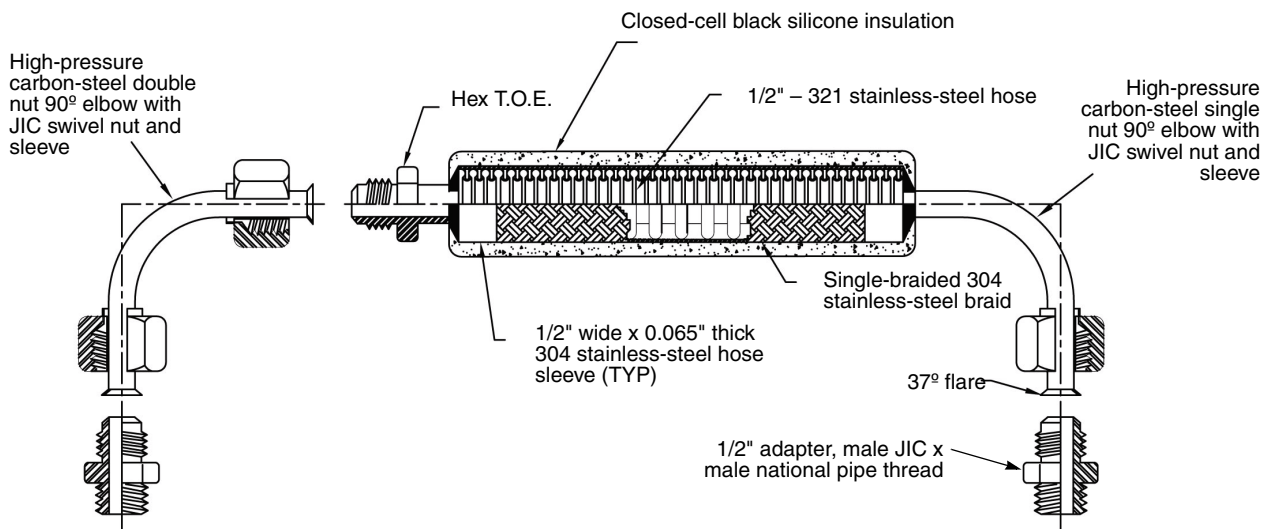

Do not use tools that can puncture – such as nails and screwdrivers – near the hose braid. Do not clamp pipe wrenches or vise grips on the hose braid or its sleeve components. Do not torque or twist the hose component when installing the jumper.

The hose component of the heating medium jumper is a thin-walled pressure-containing device that is designed to offer superior lifespan. Improper installation practices can adversely affect the lifespan of the jumper.

Tools required

You need the following tools to install the jumpovers:

- Two adjustable or pipe wrenches
- Appropriately sized and plant-approved thread-sealing medium

Note: Additional tools may be required, depending on the jumper connection design. The connection design may vary according to the customer specification.

Procedure

1. Verify that the connection of the jumper matches the connection of the ControHeat jacket.
2. Verify that the jumper is the proper length. Hold the jumper between the heating medium pipe connection and the jacket connection. Do not stretch the jumper to make it fit.
3. Prepare the jumper connection using the thread-sealing medium. If you have threaded connections, place the thread-sealing medium around the male threads.

Note: Do not use thread-sealing medium on the JIC swivel nut threads. The thread-sealing medium can interfere with the metal-to-metal seat of the adapter and the tube flare.

4. Using the tools required, connect and tighten the jumper connection into the jacket connection.

Note: If the jumper connection is designed to include one fixed (or stationary) end and one swivel (or adjustable) end, install the fixed end into the jacket connection first, leaving the swivel end for adjustments when connecting to the heating medium piping.

5. Connect and tighten the other jumper connection to the connection on the heating medium piping.
6. Repeat this procedure for each jumper you install.

Installation examples

Figure 4 illustrates how to install a heating medium jumper for proper condensate drainage. Figure 5 provides examples of a typical installation on jacketed Micro Motion sensors.

Figure 4 Installation of heating medium jumpovers for proper condensate drainage

Install the jumper in the curve down position to allow the condensate to freely drain out of the ControHeat jacket.

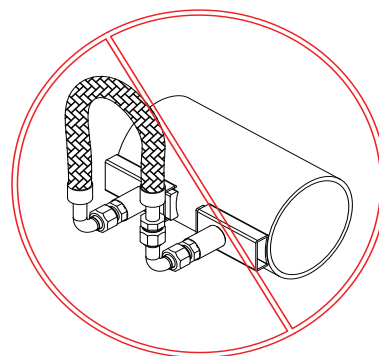
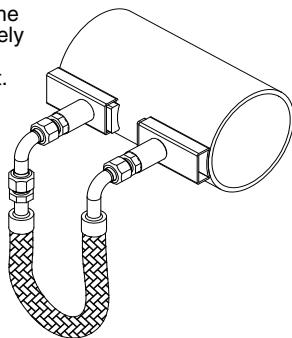

If you install the jumper in the curve up position, the condensate collects in the ControHeat jacket and degrades the heat transfer from the system.

Figure 5 Installation of heating medium jumpovers on jacketed Micro Motion sensors

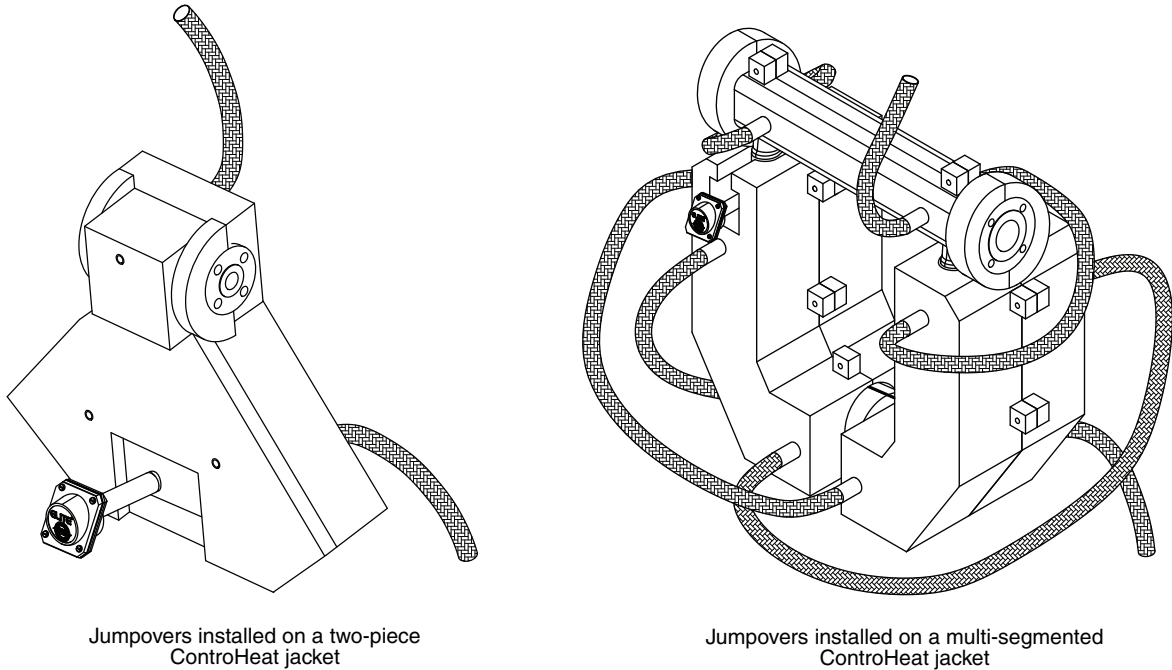

Step 3: Attaching a ControCover Insulation Blanket

Before you begin

The ControCover insulation blanket is custom-designed and manufactured for specific ControHeat jackets.

Tools required

You need the following tools to attach the ControCover insulation blanket:

- Tie wraps or wire ties (included with the shipment)
- A pair of wire cutters

Procedure

1. Place the insulation blanket over the sensor installation.
2. Secure the blanket in place using the lacing anchors and tie wraps/wire ties. Trim the excess length of the tie wraps or wire ties with the wire cutters.
3. Using the drawcord provided, draw down and secure the flaps over the pipe or pipe covering adjacent to the sensor installation (if required in the field).

Removing a ControHeat Jacket

Before you begin

If you need to service the Micro Motion sensor, you may need to remove the ControHeat jacket, service the sensor, and reinstall the jacket to the sensor. If you used heat-transfer cement in the original installation, you need to remove any excess cement that may inhibit a proper fit when reinstalling the jacket.



Verify that the heating medium is not being applied and that the ControHeat jacket and jumpovers are cool before you begin the process to remove the jacket from the sensor.

Tools required

You need the following tools to remove a ControHeat jacket:

- Rubber or plastic mallet
- Open-end or adjustable wrenches
- A hand chisel
- A prying device (optional)

Procedure

1. Remove the ControCover insulation blanket.
2. Remove the heating medium jumpovers from the jacket segments.
3. Remove the fasteners that are holding jacket segments on the sensor.
4. Tap the jacket segments lightly with a rubber or plastic mallet to dislodge the segments from the sensor. You can pry the jacket segments apart with the hand chisel or other prying device, but do this carefully to ensure you do not damage the jacket segments.
5. If you plan to reinstall the heat jacket, use the hand chisel to remove any heat-transfer cement remaining on the sensor surface. Also, remove any substantial areas of cement adhering to the inner surface of the jacket segments. You do not need to remove any residual traces of the cement from the the inner surface of the jacket segments. These traces do not affect a proper fit or inhibit the thermal performance of the jacket when reusing or reinstalling the heat jacket.
6. The ControHeat jacket is ready for reuse. To reinstall the ControHeat jacket, see *Step 1: Installing a ControHeat Jacket* on page 3 for more information.

Contacting Controls Southeast, Inc.

For more information regarding the Controls Southeast, Inc. products, contact:

Controls Southeast, Inc.
12201 Nations Ford Road
Pineville, NC 28134
704-644-5000
www.csiheat.com

© 2008 Micro Motion, Inc. All rights reserved. P/N MMI-20013331, Rev. AA



For the latest Micro Motion product specifications, view the
PRODUCTS section of our web site at www.micromotion.com

Micro Motion Inc. USA

Worldwide Headquarters

7070 Winchester Circle
Boulder, Colorado 80301

T +1 303-527-5200

+1 800-522-6277

F +1 303-530-8459

Micro Motion Europe

Emerson Process Management

Neonstraat 1

6718 WX Ede

The Netherlands

T +31 (0) 318 495 555

F +31 (0) 318 495 556

Micro Motion Asia

Emerson Process Management

1 Pandan Crescent

Singapore 128461

Republic of Singapore

T +65 6777-8211

F +65 6770-8003

Micro Motion United Kingdom

Emerson Process Management Limited

Horsfield Way

Bredbury Industrial Estate

Stockport SK6 2SU U.K.

T +44 0870 240 1978

F +44 0800 966 181

Micro Motion Japan

Emerson Process Management

1-2-5, Higashi Shinagawa

Shinagawa-ku

Tokyo 140-0002 Japan

T +81 3 5769-6803

F +81 3 5769-6844

