

Mounting Instructions

D103442X012
May 2010

DVC6200 or DVC2000 Digital Valve Controller on 657 and 667 Size 34-60 Actuators with Handwheel

Use these instructions to mount a Fisher® FIELDVUE™ DVC6200 or DVC2000 digital valve controller on Fisher 657 and 667 size 34-60 actuators w/handwheel.



WARNING

Avoid personal injury or property damage from sudden release of process pressure or bursting of parts. Before performing any maintenance operations:

- **Always wear protective clothing, gloves, and eyewear.**
- **Do not remove the actuator from the valve while the valve is still pressurized.**
- **Disconnect any operating lines providing air pressure, electric power, or a control signal to the actuator. Be sure the actuator cannot suddenly open or close the control valve.**
- **Use bypass valves or completely shut off the process to isolate the control valve from process pressure. Relieve process pressure from both sides of the control valve.**
- **Vent the pneumatic actuator loading pressure and relieve any actuator spring precompression.**
- **Use lock-out procedures to be sure that the above measures stay in effect while you work on the equipment.**
- **Check with your process or safety engineer for any additional measures that must be taken to protect against process media.**

Refer to figure 2 and the parts list for mounting parts identification. Refer to the DVC6200 or DVC2000 digital valve controller instruction manual for digital controller parts identification. Refer to the appropriate actuator instruction manual for actuator installation, operation, maintenance, and parts identification.

1. Isolate the control valve from the process line pressure and release pressure from both sides of the valve body. Shut off all pressure lines to the actuator, releasing all pressure from the actuator. Use lock-out procedures to be sure that the above measures stay in effect while you work on the equipment.

2. Attach the connector arm (key 3) to the valve stem by loosening the valve stem jam nuts and inserting the connector arm between the travel indicator disk and jam nuts. Ensure the connector arm is visually square with the yoke legs and seated against the valve stem and retighten the jam nuts.

3. Attach the extension arm (key 6) to the connector arm using two pan head machine screws (key 4) but do not tighten. See figure 2 for extension arm orientation.

4. Attach the magnet assembly (key 5) to the extension arm with two pan head machine screws (key 4) but do not tighten (the magnet assembly can be inverted 180° without effect).

5. Attach the mounting bracket assembly (key 1) to the yoke using the two socket head screws (key 2).

6. Push the cap screws and O-ring in the mounting bracket groove and then attach the black plastic alignment template to the mounting bracket by inserting the two protruding posts into the mounting holes in the bracket and simultaneously positioning the magnet assembly so that it can slide into the channel in the alignment template. The magnet assembly should be fully in the alignment template channel so that the extension arm is contacting the back of the alignment template but not bending it. Tighten pan head machine screws (key 4), attaching the extension arm to the connector arm but do not yet tighten the pan head machine screws attaching the magnet assembly.

7. For an air-to-extend actuator, slide the magnet assembly (key 5) so that the bottom marking aligns with the sensor index mark on the alignment template (see figure 1). The magnet assembly's top marking is used for air-to-retract. The mounting bracket may require vertical repositioning to get the magnet array in the correct location. When the magnet assembly is properly positioned, remove the alignment template and tighten the two pan head machine screws (key 4).

8. Attach the digital valve controller to the mounting bracket and tighten the three hex head cap screws (key 1b).

9. Check the position of the magnet assembly (key 5) in the channel of the digital valve controller housing and ensure the feedback array is visually centered between the channel walls and has adequate clearance with the backside of the channel (approximately 3 mm).



DVC6200 or DVC200 Digital Valve Controller on 657 and 667 Size 34-60 Actuators with Handwheel

Mounting Instructions
D103442X012
May 2010

10. Connect and calibrate the digital valve controller as described in the instruction manual or quick start guide.

For additional information concerning mounting, setup, calibration or maintenance of the DVC6200 or DVC2000 digital valve controller, refer to the appropriate instruction manual.

Note

Neither Emerson, Emerson Process Management, nor any of their affiliated entities assumes responsibility for the selection, use, or maintenance of any product. Responsibility for the selection, use, and maintenance of any product remains with the purchaser and end user.

FIGURE SHOWS MAGNET ASSEMBLY MARKING ALIGNED WITH SENSOR INDEX MARK FOR AIR-TO-EXTEND ACTUATOR

ASSEMBLY MARKING

NOTE:
DURING THE COMPLETE STROKE OF THE ACTUATOR, AT ANY PARTICULAR POSITION, THE DIGITAL VALVE CONTROLLER HALL SENSOR MUST REMAIN WITHIN THE MARKING SHOWN ON THE MAGNET ASSEMBLY

GE43826

Figure 1. Alignment Template

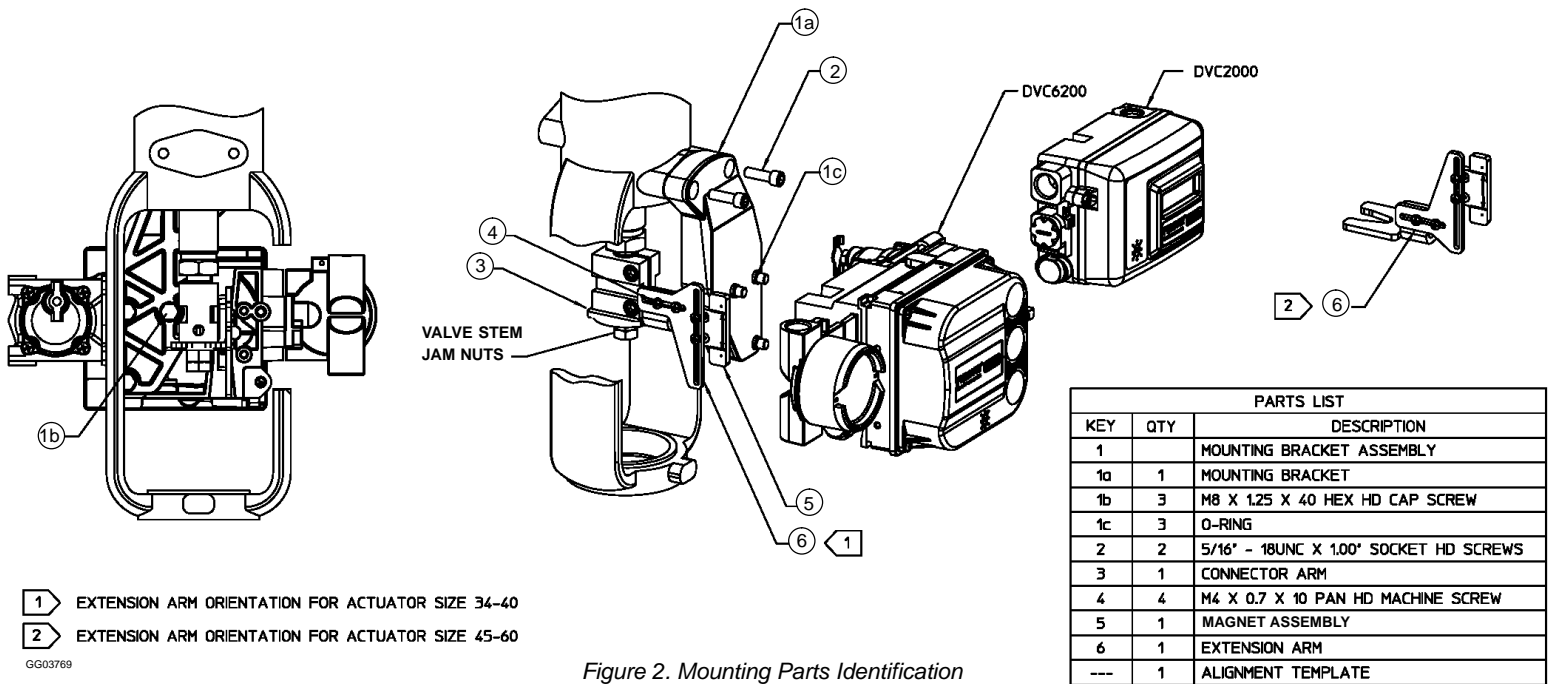

Figure 2. Mounting Parts Identification

- 1 EXTENSION ARM ORIENTATION FOR ACTUATOR SIZE 34-40
- 2 EXTENSION ARM ORIENTATION FOR ACTUATOR SIZE 45-60

GG03769

Fisher and FIELDVUE are marks owned by one of the companies in the Emerson Process Management business division of Emerson Electric Co. Emerson Process Management, Emerson, and the Emerson logo are trademarks and service marks of Emerson Electric Co. All other marks are the property of their respective owners.

The contents of this publication are presented for informational purposes only, and while every effort has been made to ensure their accuracy, they are not to be construed as warranties or guarantees, express or implied, regarding the products or services described herein or their use or applicability. All sales are governed by our terms and conditions, which are available upon request. We reserve the right to modify or improve the designs or specifications of such products at any time without notice. Neither Emerson, Emerson Process Management, nor any of their affiliated entities assumes responsibility for the selection, use or maintenance of any product. Responsibility for proper selection, use, and maintenance of any product remains solely with the purchaser and end user.

Emerson Process Management
Marshalltown, Iowa 50158 USA
Sorocaba, 18087 Brazil
Chatham, Kent ME4 4QZ UK
Dubai, United Arab Emirates
Singapore 128461 Singapore

www.Fisher.com

