

# Fisher™ FIELDVUE™ DVC2000 Digital Valve Controller

This manual applies to

Instrument Level	HC, AD, PD	AC
Device Type	05	F5
Device Revision	1	1
Hardware Revision	1 & 2	1 & 2
Firmware Revision	1, 2, 3, 4 & 5	1, 2, 3, 4 & 5
DD Revision	3	1

## Contents

### Section 1 Introduction and Specifications . 3

Installation, Electrical and Pneumatic Connections,  
and Basic Setup and Calibration ..... 3

Scope of Manual ..... 3

Instrument Description ..... 3

Terminology ..... 4

Specifications ..... 4

Related Documents ..... 7

Educational Services ..... 8

### Section 2 Detailed Setup and Calibration via HART Communication ..... 9

Detailed Setup ..... 9

Setting Modes ..... 9

    Instrument Mode ..... 9

    Control Mode ..... 9

    Restart Control Mode ..... 10

    Restarting the Instrument ..... 10

    Burst Mode ..... 10

Protection ..... 12

General Information ..... 14

    HART Tag

    Message Descriptor

    Date

    Valve Serial Number

    Instrument Serial Number

    Polling Address

    LUI Language



W8755

Measured Variable Units and Ranges ..... 15

    Analog Input Units

    Analog Input Range High and Low

    Pressure Units

    Temperature Units

Actuator and Valve Information ..... 16

    Maximum Supply Pressure

    Actuator Style

    Valve Serial Number

    Valve Style

    Zero Control Signal

Setting Response ..... 16

    Tuning Set

    Damping Factor

    Expert Tuning Gains

    Input Characteristic

    Custom Characteristic Table

    Set Point Filter Time

    Limits and Cutoffs

    Minimum Opening and Closing Time

    Integral Settings

Setting Alerts ..... 19

    Travel Alerts ..... 20

    Cycle Counter Alert ..... 22

    Other Alerts ..... 23

    Alert Record ..... 23

Self-Test Failure for Instrument Shutdown ..... 24  
 Transmitter/Switches ..... 25  
 Tuning ..... 26  
   Automatic ..... 26  
   Manual ..... 26  
 Calibration ..... 27  
   Analog Input Calibration ..... 27  
     Using the Field Communicator ..... 27  
     Using Local Operator Interface ..... 28  
   Auto Calibrate Travel ..... 28  
   Manual Calibrate Travel ..... 29  
     Analog Calibration Adjust ..... 29  
     Digital Calibration Adjust ..... 29  
   Pressure Sensor Calibration ..... 30  
     Output Pressure Sensor ..... 30  
   Position Transmitter ..... 31  
**Section 3 Viewing Device Variables and  
 Diagnostics ..... 33**  
 Viewing Variables ..... 33  
   Analog Input, Travel, Valve Set Point, Drive Signal  
   and Output Pressure ..... 33  
   Additional Instrument Variables ..... 33  
 Viewing Device Information ..... 34  
 Viewing Instrument Status ..... 35

**Section 4 Maintenance and  
 Troubleshooting ..... 39**  
 Stroking the Digital Valve Controller Output ..... 39  
 Replacing the Instrument ..... 40  
 Replacing the Magnetic Feedback Assembly ..... 41  
 Component Replacement ..... 41  
   Replacing the I/P Converter ..... 41  
   Replacing the Pneumatic Relay ..... 43  
 Troubleshooting ..... 44  
 Checking Available Voltage ..... 46  
 Technical Support Checklist ..... 47  
**Section 5 Parts ..... 49**  
 Parts Ordering ..... 49  
 Parts Kits ..... 49  
 Parts List ..... 50  
**Appendix A Principle of Operation ..... 55**  
 DVC2000 Operation ..... 55  
**Appendix B Local Interface Flow Chart and  
 Field Communicator Menu Trees ..... 57**  
**Glossary ..... 65**  
**Index ..... 73**

## Section 1 Introduction and Specifications

### Installation, Electrical and Pneumatic Connections, and Basic Setup and Calibration using the Local Operator Interface

Refer to the DVC2000 Quick Start Guide ([D103203X012](#)) for DVC2000 installation, connection, and basic setup and calibration using the local operator interface. If a copy of this quick start guide is needed scan or click the QR code at the right, contact your Emerson sales office, Local Business Partner, or visit our website at [Fisher.com](#).



Scan or click  
to access  
field support

### Scope of Manual

This instruction manual is a supplement to the quick start guide that ships with every instrument. This instruction manual includes specifications, detailed configuration and calibration using a Field Communicator, maintenance and troubleshooting information and replacement part details.

---

#### Note

ValveLink software can also be used for detailed configuration and calibration, as well as performing diagnostic and performance tests. For information on using ValveLink software with the instrument, refer to the appropriate user guide or help.

---

Do not install, operate, or maintain a DVC2000 digital valve controller without being fully trained and qualified in valve, actuator, and accessory installation, operation, and maintenance. **To avoid personal injury or property damage, it is important to carefully read, understand, and follow all of the contents of this manual, including all safety cautions and warnings.** If you have any questions regarding these instructions, contact your Emerson sales office or Local Business Partner before proceeding.

### Instrument Description

The DVC2000 digital valve controller is a communicating, microprocessor-based current-to-pneumatic valve positioner. It is designed to replace standard pneumatic and electro-pneumatic valve positioners.

In addition to the traditional function of converting an input current signal (4-20 mA) to a pneumatic output pressure, the DVC2000 digital valve controller communicates via a local display panel and/or via the HART® protocol. An option is available which provides isolated circuitry for two (2) integrated limit switches (for open/close valve indication) and a valve position transmitter (for separate valve position feedback).

## Terminology

*Instrument Level*— There are four (4) levels of functionality available: AC, HC, AD and PD.

*AC*—This level provides the capability to setup and calibrate the positioner through the LCD or the Field Communicator.

*HC*—This level provides additional capability for advanced configuration of the positioner (such as travel limits/cutoffs, custom characterization, and minimum open/closing time). Also, information is available through the HART protocol for diagnostic alerts such as travel deviation, cycle count, and travel accumulation.

*AD*—This level provides advanced diagnostic capabilities for performance testing. When used with ValveLink software, instrument health can be evaluated with tests such as Valve Signature, step response and dynamic error band. The software program provides detailed analysis with graphics.

*PD*—This level provides automated, non-intrusive testing of the operating performance of the control valve assembly. When used with ValveLink software, tests to isolate component degradation can be run on the valve assembly without affecting the process.

*Local Interface*— The DVC2000 comes standard with a Liquid Crystal Display (LCD) and four (4) pushbuttons. The local interface provides the capability to setup and calibrate the positioner and view basic diagnostic messages.

*Magnet Assembly*—This is the feedback component that is mounted directly to the valve stem. It supplies a magnetic field that is sensed by the digital valve controller.

*Options Board*—The DVC2000 digital valve controller is available with two (2) limit switches and a valve position transmitter. The options board includes the additional circuitry and terminations that are required to support these output signals.

*Pole Piece*—Inserted into the DVC2000 housing and protruding through the back of the instrument is a two-pronged fork that houses the magnetic sensor for position feedback.

## Specifications

Specifications for the DVC2000 digital valve controller are shown in table 1-1. Specifications for the Field Communicator can be found in the [User's Manual](#).

### **⚠ WARNING**

**This product is intended for a specific range of application specifications. Incorrect configuration of a positioning instrument could result in the malfunction of the product, property damage, or personal injury.**

Table 1-1. Specifications

<p><b>Available Configurations</b></p> <ul style="list-style-type: none"> <li>■ Integral mounting to the Fisher GX Control Valve and Actuator System</li> <li>■ Sliding-stem applications</li> <li>■ Quarter-turn rotary applications</li> </ul> <p>The DVC2000 digital valve controller can also be mounted on other actuators that comply with IEC 60534-6-1, IEC 60534-6-2, VDI/VDE 3845 and NAMUR mounting standards.</p> <p><b>Input Signal</b></p> <p><b>Analog Input Signal:</b> 4-20 mA DC, nominal; split ranging available</p> <p><b>Minimum Voltage:</b> Voltage available at instrument terminals must be 8.5 volts for analog control, 9.0 volts for HART communication</p> <p><b>Maximum Voltage:</b> 30 volts DC</p> <p><b>Minimum Control Current:</b> 4.0 mA (below 3.5 mA may cause microprocessor restart)</p> <p><b>Overcurrent Protection:</b> Input circuitry limits current to prevent internal damage</p> <p><b>Reverse Polarity Protection:</b> No damage occurs from reversal of loop current</p> <p><b>Output Signal</b></p> <p>Pneumatic signal as required by the actuator, up to full supply pressure</p> <p><b>Minimum Span:</b> 0.5 bar (7 psig)</p> <p><b>Maximum Span:</b> 7 bar (101 psig)</p> <p><b>Action:</b> Single Acting, direct</p> <p><b>Supply Pressure<sup>(1)</sup></b></p> <p><b>Recommended:</b> 0.5 bar (7 psig) greater than the maximum actuator requirements</p> <p><b>Maximum:</b> 7 bar (101 psig)</p> <p>Supply pressure medium must be clean, dry air or noncorrosive gas</p> <p><b>Per ISA Standard 7.0.01</b></p> <p>A maximum 40 micrometer particle size in the air system is acceptable. Further filtration down to 5 micrometer particle size is recommended. Lubricant content is not to exceed 1 ppm weight (w/w) or volume (v/v) basis. Condensation in the air supply should be minimized</p> <p><b>Per ISO 8573-1</b></p> <p><i>Maximum particle density size:</i> Class 7</p> <p><i>Oil content:</i> Class 3</p> <p><i>Pressure Dew Point:</i> Class 3 or at least 10°C less than the lowest ambient temperature expected</p>	<p><b>Temperature Limits<sup>(1)</sup></b></p> <p>-40 to 85°C (-40 to 185°F). LCD may not be readable below -20°C (-4°F).</p> <p><b>Air Consumption<sup>(2)</sup></b></p> <p><b>Supply pressure:</b></p> <p><i>At 1.5 bar (22 psig)<sup>(3)</sup>:</i> 0.06 normal m<sup>3</sup>/h (2.3 scfh)</p> <p><i>At 4 bar (58 psig)<sup>(4)</sup>:</i> 0.12 normal m<sup>3</sup>/h (4.4 scfh)</p> <p><b>Air Capacity<sup>(2)</sup></b></p> <p><b>Supply pressure:</b></p> <p><i>At 1.5 bar (22 psig)<sup>(3)</sup>:</i> 4.48 normal m<sup>3</sup>/h (167 scfh)</p> <p><i>At 4 bar (58 psig)<sup>(4)</sup>:</i> 9.06 normal m<sup>3</sup>/h (338 scfh)</p> <p><b>Independent Linearity</b></p> <p>±0.5% of output span</p> <p><b>Electromagnetic Compatibility</b></p> <p>Meets EN 61326-1:2013</p> <p>Immunity—Industrial locations per Table 2 of the EN 61326-1 standard. Performance is shown in table 1-2 below</p> <p>Emissions—Class A</p> <p>ISM equipment rating: Group 1, Class A</p> <p>Tested to NAMUR NE21 requirements.</p> <p><b>Vibration Testing Method</b></p> <p>Tested per ANSI/ISA 75.13.01 Section 5.3.5. A resonant frequency search is performed on all three axes. The instrument is subjected to the ISA specified 1/2 hour endurance test at each major resonance, plus an additional two million cycles.</p> <p><b>Input Impedance</b></p> <p>The input impedance of the DVC2000 active electronic circuit is not purely resistive. For comparison to resistive load specifications, an equivalent impedance of 450 ohms may be used. This value corresponds to 9 V @ 20 mA.</p> <p><b>Electrical Classification</b></p> <p><b>Hazardous Area:</b></p> <ul style="list-style-type: none"> <li>CSA—Intrinsically Safe and Non-incendive</li> <li>FM—Intrinsically Safe and Non-incendive</li> <li>ATEX—Intrinsically Safe</li> <li>IECEx—Intrinsically Safe</li> </ul>
---	---

-continued-

Table 1-1. Specifications (continued)

<p><b>Electrical Housing:</b> CSA—IP66 and Type 4X FM, ATEX, IECEx—IP66</p> <p><b>Other Classifications/Certifications</b> CUTR— Customs Union Technical Regulations (Russia, Kazakhstan, Belarus, and Armenia) INMETRO—National Institute of Metrology, Quality and Technology (Brazil) KGS— Korea Gas Safety Corporation (South Korea) NEPSI—National Supervision and Inspection Centre for Explosion Protection and Safety of Instrumentation (China) PESO CCOE— Petroleum and Explosives Safety Organisation - Chief Controller of Explosives (India) Contact your <a href="#">Emerson sales office</a> or Local Business Partner for classification/certification specific information</p> <p><b>Connections</b> <b>Standard</b> <i>Supply and Output Pressure:</i> G1/4 internal Electrical: M20 internal <b>Optional</b> <i>Supply and Output Pressure:</i> 1/4 NPT internal Electrical: 1/2 NPT internal</p> <p><b>Materials of Construction</b> Housing and Cover: A03600 low copper aluminum alloy Elastomers: nitrile, fluorosilicone</p> <p><b>Stem Travel</b> Minimum: 6.35 mm (0.25 inch) Maximum: 606 mm (23-7/8 inches)</p> <p><b>Shaft Rotation</b> Minimum: 45° Maximum: 90°</p>	<p><b>Mounting</b> Designed for direct actuator mounting. For weatherproof housing capability, the vent must be positioned at the lowest point of the instrument.</p> <p><b>Weight</b> 1.5 kg (3.3 lbs)</p> <p><b>Options</b>  <ul style="list-style-type: none"> <li>■ <b>Airset:</b> 67CFR with filter</li> </ul> <b>Language Packs:</b>  <ul style="list-style-type: none"> <li>■ <b>Standard:</b> English, German, French, Italian, Spanish, Japanese, Chinese, Portuguese, Russian, Polish, and Czech</li> <li>■ <b>Optional:</b> English, German, French, Italian, Spanish, Japanese, Chinese, and Arabic</li> <li>■ <b>Pipe-away vent</b></li> <li>■ <b>Limit Switches:</b> Two isolated switches, configurable throughout calibrated travel range <i>Supply Voltage:</i> 5-30 VDC <i>OFF State:</i> 0.5 to 1.0 mA <i>ON State:</i> 3.5 to 4.5 mA (above 5 V) <i>Reference Accuracy:</i> 2% of travel span<sup>(5)</sup></li> <li>■ <b>Transmitter:</b> 4-20 mA output, isolated <i>Supply Voltage:</i> 8-30 VDC <i>Fault Indication:</i> offrange high or low <i>Reference Accuracy:</i> 1% of travel span<sup>(5)</sup></li> </ul> </p> <p><b>Declaration of SEP</b> Fisher Controls International LLC declares this product to be in compliance with Article 4 paragraph 3 of the PED Directive 2014/68/EU. It was designed and manufactured in accordance with Sound Engineering Practice (SEP) and cannot bear the CE marking related to PED compliance.  However, the product <i>may</i> bear the CE marking to indicate compliance with <i>other</i> applicable European Community Directives.</p>
--	--

1. The pressure/temperature limits in this document and any applicable standard or code limitation should not be exceeded. Note: Temperature limits vary based on hazardous area approval.  
2. Normal m<sup>3</sup>/hour - Normal cubic meters per hour at 0°C and 1.01325 bar, absolute. Scfh - Standard cubic feet per hour at 60°F and 14.7 psia.  
3. Low pressure relay: 0 to 3.4 bar (0 to 50 psig).  
4. High pressure relay: 3.5 to 7.0 bar (51 to 102 psig).  
5. Typical values when calibrated at temperature.

Table 1-2. EMC Summary Results—Immunity

Port	Phenomenon	Basic Standard	Test Level	Performance Criteria <sup>(1)</sup>
Enclosure	Electrostatic discharge (ESD)	IEC 61000-4-2	6 kV contact 8 kV air	B
	Radiated EM field	IEC 61000-4-3	80 to 1000 MHz @ 10V/m with 1 kHz AM at 80% 1400 to 2000 MHz @ 3V/m with 1 kHz AM at 80% 2000 to 2700 MHz @ 1V/m with 1 kHz AM at 80%	A
	Rated power frequency magnetic field	IEC 61000-4-8	30 A/m at 50 Hz, 60 sec	A
I/O signal/control	Burst (fast transients)	IEC 61000-4-4	± 1 kV	A
	Surge	IEC 61000-4-5	± 1 kV (line to ground only, each)	B
	Conducted RF	IEC 61000-4-6	150 kHz to 80 MHz at 10 Vrms	A

Performance criteria is +/- 1% effect.  
1. A = No degradation during testing. B = Temporary degradation during testing, but is self-recovering.

## Related Documents

Other documents containing information related to the DVC2000 digital valve controller include:

- DVC2000 Digital Valve Controller Quick Start Guide ([D103203X012](#))
- Bulletin 62.1:DVC2000 ([D103167X012](#))
- INMETRO Hazardous Area Approvals for FIELDVUE DVC2000 Digital Valve Controller ([D103780X012](#))
- FIELDVUE Digital Valve Controller Split Ranging ([D103262X012](#))
- Using FIELDVUE Instruments with the Smart HART Loop Interface and Monitor (HIM) ([D103263X012](#))
- Audio Monitor for HART Communications ([D103265X012](#))
- HART Field Device Specification - Fisher FIELDVUE DVC2000 Digital Valve Controller ([D103783X012](#))
- Using the HART Tri-Loopt HART-to-Analog Signal Converter with Fisher FIELDVUE Digital Valve Controllers ([D103267X012](#))

These documents are available from your Emerson sales office, Local Business Partner, or at [Fisher.com](http://Fisher.com).

## Educational Services

For information on available courses for the DVC2000 digital valve controller, as well as a variety of other products, contact:

Emerson Automation Solutions  
Educational Services - Registration  
Phone: 1-641-754-3771 or 1-800-338-8158  
E-mail: [education@emerson.com](mailto:education@emerson.com)  
[emerson.com/fishervalvetraining](http://emerson.com/fishervalvetraining)



## Section 2 Detailed Configuration and Calibration via HART Communication

### Detailed Setup

The DVC2000 digital valve controller has the capability to communicate via the HART protocol. This section describes the advanced features that can be accessed with the Field Communicator. Table 2-1 lists the default settings for a standard factory configuration. Table 2-2 provides the actuator information required to setup and calibrate the instrument.

### Setting Modes

Field Communicator	Setup & Diag > Detailed Setup > Mode (1-2-1)
--------------------	--

### Instrument Mode

You can change the instrument mode by selecting *Instrument Mode* from the *Mode* menu, or press the Hot Key and select *Instrument Mode*.

Instrument Mode allows you to either take the instrument Out Of Service or place it In Service. Taking the instrument Out Of Service allows you to perform instrument calibration and also allows you to change setup variables that affect control, provided the calibration/configuration protection is properly set. See Setting Protection.

---

#### Note

Some changes that require the instrument to be taken Out Of Service will not take effect until the instrument is placed back In Service or the instrument is restarted.

---

### Control Mode

You can change the control mode by selecting *Control Mode* from the *Mode* menu, or press the Hot Key and select *Control Mode*.

Control Mode lets you define where the instrument receives its set point. Follow the prompts on the Field Communicator display to choose one of the following control modes: Analog or Digital.

Choose Analog if the instrument is to receive its set point over the 4-20 mA loop. Normally the instrument control mode is Analog.

Choose Digital if the instrument is to receive its set point digitally, via the HART communications link.

A third mode, Test, is also displayed. Normally the instrument should not be in the Test mode. The Field Communicator automatically switches to this mode whenever it needs to stroke the valve, for example during

calibration or stroke valve. However, if you abort from a procedure where the instrument is in the Test mode, it may remain in this mode. To take the instrument out of the Test mode, select *Control Mode* then select either Analog or Digital.

## Restart Control Mode

Restart Control Mode (*Restart Cont Mode*) lets you choose which operating mode you want the instrument to be in after a restart. Follow the prompts on the Field Communicator display to define the restart control mode as Resume Last, Analog, or Digital.

## Restarting the Instrument

Restart resets the instrument in the same manner as when power to the instrument is interrupted. When Restart is issued, all of the newly entered configuration variables become active. Otherwise, they may not take effect until the instrument is placed In Service.

## Burst Mode

Enabling burst mode provides continuous communication from the digital valve controller. Burst mode applies only to the transmission of burst mode data (analog input, travel target, pressure, and travel) and does not affect the way other data is accessed.

Access to information in the instrument is normally obtained through the poll/response of HART communication. The Field Communicator or the control system may request any of the information that is normally available, even while the instrument is in burst mode. Between each burst mode transmission sent by the instrument, a short pause allows the Field Communicator or control system to initiate a request. The instrument receives the request, processes the response message, and then continues “bursting” the burst mode data.

There are four burst mode commands. Command 3 is recommended for use with the Rosemount® 333 HART Tri-Loop™ HART-to-analog signal converter. The other three are not used at this time.

Command 3 provides the following variables:

- Primary variable—analog input in % or mA,
- Secondary variable—travel target (valve set point) in % of ranged travel,
- Tertiary variable—output pressure in psig, bar, or kPa,
- Quaternary variable—travel in % of ranged travel.

To enable burst mode select *Mode > Burst > Burst Enable*. To send a burst mode command, select *Burst Command*. Burst mode must be enabled before you can change the burst mode command.

Table 2-1. Factory Default Detailed Setup Parameters

Setup Parameter	Default Setting <sup>(1)</sup>
Control Mode	Analog
Restart Control Mode	Resume Last
Burst Mode Enabled	No
Burst Mode Command	3
HART Tag	As specified on order
Message	Blank
Description	Blank
Date	Factory Calibration Date
Valve Serial Number	Blank
Polling Address	0
Max Supply Pressure	100 <sup>(2)</sup>
Zero Control Signal	Open <sup>(2)</sup>
Analog Input Units	mA
Analog In Range High	20 mA
Analog In Range Low	4.0 mA
Travel Range High	100%
Travel Range Low	0%
Pressure Units	PSI <sup>(2)</sup>
Temperature Units	F
Input Characteristic	Linear
Setpoint Filter Time	Filter Off
Travel Limit High	125%
Travel Limit Low	-25%
Travel Cutoff High	99.5%
Travel Cutoff Low	0.5%
Minimum Opening Time	0 secs
Minimum Closing Time	0 secs
Integral Gain	1 repeat/minute
Integral Deadband	0.5%
Travel Hi/Lo Alert Enabled	No
Travel Hi Hi/Lo Lo Alert Enabled	No
Travel Alert High Point	125%
Travel Alert Low Point	-25%
Travel Alert High-High Point	125%
Travel Alert Low-Low Point	-25%
Travel Alert Deadband	1%
Travel Deviation Alert Enable	Yes
Travel Deviation Alert Point	7%
Travel Deviation Time	5 secs
Cycle Counter Alert Enable	No
Cycle Counter Alert Point	2,147,483,646
Cycle Counter Deadband	3%
Cycle Counter	0
Travel Accumulator Alert Enable	No
Travel Accumulator Alert Point	2,147,483,646%
Travel Accumulator Deadband	3%
Travel Accumulator	0
Drive Alert Enable	No
Flash ROM Fail	No
Ref Voltage Fail	No
Drive Current Fail	No
Critical NVM Fail	No
Temperature Sensor Fail	No
Pressure Sensor Fail	No
Travel Sensor Fail	No

1. The settings listed are for standard factory configuration. DVC2000 instruments can also be ordered with custom configuration settings. For the default custom settings, refer to the order requisition.  
 2. If the instrument is shipped mounted on an actuator, these values depend upon the actuator on which the instrument is mounted.

Table 2-2. Actuator Information for Setup

Actuator Manufacturer	Actuator Model	Actuator Style	Actuator Size	Starting Tuning Set	Feedback Connection	
Fisher	585C & 585CR	Piston Dbl w/ or w/o Spring. See actuator instruction manual and nameplate.	25, 50, 60, 68, 80, 100, 130	Undefined	SStem-Standard for travels up to 4 inches. SStem-Roller for longer travels	
	657	Spring & Diaphragm	30, 30i	G	SStem-Standard	
			34, 34i, 40, 40i	I		
			45, 45i, 50, 50i	J		
			46, 46i, 60, 60i, 70, 70i & 80-100	Undefined		
	667	Spring & Diaphragm	30, 30i	G	SStem-Standard	
			34, 34i, 40, 40i	I		
			45, 45i, 50, 50i	J		
			46, 46i, 60, 60i, 70, 70i, 76, 76i & 80-100	Undefined		
	1051 & 1052	Spring & Diaphragm	20, 30, 33, 40, 60, 70	Undefined	Rotary	
	1066SR	Piston Sgl w/Spring	20 27, 75	Undefined	Rotary	
	3024	Spring & Diaphragm	GA 1.21 GA 1.31 GA 1.41	Undefined	SStem-Standard	
	3025	Spring & Diaphragm	P460, P462, P900	Undefined	Rotary	
	GX	Spring & Diaphragm	225	G	SStem-Standard	
750			I			
1200			K			
GX 3-Way	Spring & Diaphragm	225	G	SStem-Standard		
		750	I			
Baumann	Air to Extend	Spring & Diaphragm	16	C	SStem-Standard	
			32	D		
			54	Undefined		
			70	H		
	Air to Retract	Spring & Diaphragm	16	C	SStem-Standard	
			32	D		
			54	Undefined		
			70	H		
	Rotary	Spring & Diaphragm	10	Undefined	Rotary	
			25	Undefined		
				54	G	

## Setting Protection

Field Communicator Setup & Diag > Detailed Setup > Protection (1-2-2)

Some setup parameters may require changing the protection with the Field Communicator.

Two levels of protection are available:

- **None**—Neither setup nor calibration is protected. Allows changing calibration and setup parameters.
- **Config & Calib**—Both setup and calibration are protected. Prohibits changing calibration and protected setup parameters.

Table 2-3 lists configurable parameters in the instrument and the requirements for modifying these parameters, in terms of instrument mode and protection.

Table 2-3. Conditions for Modifying FIELDVUE DVC2000 Digital Valve Controller Parameters

Parameters	In Service/ Config Protected	In Service/ Config Unprotected	Out of Service/ Config Protected	Out of Service/ Config Unprotected
Control Mode	---	---	✓	✓
Restart Ctrl Mode	---	---	---	✓
Burst Mode Enable	✓	✓	✓	✓
Burst Mode Command Protection	---	---	---	✓
	✓	✓	✓	✓
HART Tag	---	✓	---	✓
Message	---	✓	---	✓
Description	---	✓	---	✓
Date	---	✓	---	✓
Valve Serial Num	---	✓	---	✓
Inst Serial Num	---	---	---	✓
Polling Address	---	---	---	✓
Max Supply Pressure	---	---	---	✓
Zero Ctrl Signal	---	---	---	✓
Analog In Units	---	---	---	✓
Input Range High	---	---	---	✓
Input Range Low	---	---	---	✓
Pressure Units	---	---	---	✓
Temp Units	✓	✓	✓	✓
Tuning Set	---	✓	---	✓
Prop Gain	---	✓	---	✓
Velocity Gain	---	✓	---	✓
MLFB Gain	---	✓	---	✓
Input Char	---	---	---	✓
Define Custom Char	---	---	---	✓
Set Pt Filter Time	---	---	---	✓
Tvl Limit High	---	---	---	✓
Tvl Limit Low	---	---	---	✓
Tvl Cutoff High	---	---	---	✓
Tvl Cutoff Low	---	---	---	✓
Min Opening Time	---	---	---	✓
Min Closing Time	---	---	---	✓
Integral Gain	---	✓	---	✓
Integral Deadband	---	✓	---	✓
Tvl Hi/Lo Enab	✓	✓	✓	✓
Tvl HH/LL Enab	✓	✓	✓	✓
Tvl Alert Hi Pt	✓	✓	✓	✓
Tvl Alert Lo Pt	✓	✓	✓	✓
Tvl Alert HiHi Pt	✓	✓	✓	✓
Tvl Alert LoLo Pt	✓	✓	✓	✓
Tvl Alrt DB	✓	✓	✓	✓
Tvl Dev Alrt Enab	✓	✓	✓	✓
Tvl Dev Alrt Pt	✓	✓	✓	✓
Tvl Dev Time	✓	✓	✓	✓
Cycl Cnt Alrt Enab	✓	✓	✓	✓
Cycl Count Alrt Pt	✓	✓	✓	✓
Cycl Count DB	✓	✓	✓	✓
Cycl Count	✓	✓	✓	✓
Tvl Acum Alrt Enab	✓	✓	✓	✓
Tvl Acum Alrt Pt	✓	✓	✓	✓
Tvl Acum DB	✓	✓	✓	✓
Tvl Acum	✓	✓	✓	✓

✓—indicates parameter may be modified for instrument mode and protection shown.

-Continued-

Table 2-3. Conditions for Modifying FIELDVUE DVC2000 Digital Valve Controller Parameters

Parameters	In Service/ Config Protected	In Service/ Config Unprotected	Out of Service/ Config Protected	Out of Service/ Config Unprotected
Drive Alert Enable	✓	✓	✓	✓
Flash ROM Fail	---	---	---	✓
Ref Voltage Fail	---	---	---	✓
Drive Current Fail	---	---	---	✓
Critical NVM Fail	---	---	---	✓
Temp Sensor Fail	---	---	---	✓
Press Sensor Fail	---	---	---	✓
Tvl Sensor Fail	---	---	---	✓

✓—indicates parameter may be modified for instrument mode and protection shown.

To change an instrument's protection, press the Hot key on the Field Communicator display window and select *Protection* or select *Protection* from the *Detailed Setup* menu. Select the desired level of protection. Follow the prompts on the Field Communicator display to set the protection level.

## General Information

Field Communicator	Setup & Diag > Detailed Setup > General (1-2-3)
--------------------	---

Follow the prompts on the Field Communicator to enter or view information in the following fields:

- *HART Tag*—Enter an up to 8 character HART tag for the instrument. The HART tag is the easiest way to distinguish between instruments in a multi-instrument environment. Use the HART tag to label instruments electronically according to the requirements of your application. The tag you assign is automatically displayed when the Field Communicator establishes contact with the digital valve controller at power-up.
- *Message*—Enter any message with up to 32 characters. Message provides the most specific user-defined means for identifying individual instruments in multi-instrument environments.
- *Descriptor*—Enter a descriptor for the application with up to 16 characters. The descriptor provides a longer user-defined electronic label to assist with more specific instrument identification than is available with the HART tag.
- *Date*—Enter a date with the format MM/DD/YY. Date is a user-defined variable that provides a place to save the date of the last revision of configuration or calibration information.
- *Valve Serial Num*—Enter the serial number for the valve in the application with up to 12 characters.
- *Inst Serial Num*—Enter the serial number on the instrument nameplate, up to 12 characters.
- *Polling Address*—If the digital valve controller is used in point-to-point operation, the Polling Address is 0. When several devices are connected in the same loop, such as for split ranging, each device must be assigned a unique polling address. The Polling Address is set to a value between 0 and 15. To change the polling address the instrument must be Out Of Service.

For the Field Communicator to be able to communicate with a device whose polling address is not 0, it must be configured to automatically search for all or specific connected devices.

- *LUI Language*—Select the language to be displayed on the local user interface; English, French, German, Italian, Spanish, Chinese and Japanese.

## Measured Variable Units and Ranges

Field Communicator	Setup & Diag > Detailed Setup > Measured Var (1-2-4)
--------------------	--

Follow the prompts on the Field Communicator to define the following measured variables units and ranges:

- *Analog In Units*—Permits defining the Analog Input Units in mA or percent of 4-20 mA range.
- *Input Range Hi*—Permits setting the Input Range High value. Input Range High should correspond to Travel Range High, if the Zero Control Signal is configured as closed. If the Zero Control Signal is configured as open, Input Range High corresponds to Travel Range Low. See figure 2-1.
- *Input Range Lo*—Permits setting the Input Range Low value. Input Range Low should correspond to Travel Range Low, if the Zero Control Signal is configured as closed. If the Zero Control Signal is configured as open, Input Range Low corresponds to Travel Range High. See figure 2-1.
- *Pressure Units*—Defines the output and supply pressure units in either psi, bar, or kPa.
- *LUI Pressure Units*—Enter the pressure units displayed on the local user interface; psi, bar, or kPa.
- *Temp Units*—Degrees Fahrenheit or Celsius. The temperature measured is from a sensor mounted on the digital valve controller's printed wiring board.

Figure 2-1. Calibrated Travel to Analog Input Relationship

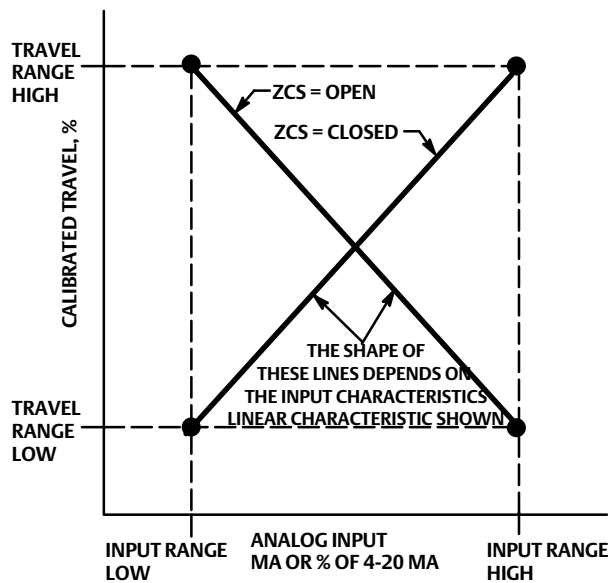

NOTE:  
ZCS = ZERO CONTROL SIGNAL

A6531-1

## Actuator and Valve Information

Field Communicator | Setup & Diag > Detailed Setup > Actuator & Valve (1-2-5)

Follow the prompts on the Field Communicator to edit or view information in the following fields:

- *Max Supply Press*—Enter the maximum supply pressure in psi, bar, or kPa, depending on what was selected for pressure units.

---

### Note

If the actual measured pressure exceeds this setting by 25%, the pressure measurement will not be displayed.

---

- *Actuator Style*—Enter the actuator style, spring and diaphragm, piston double-acting without spring, piston single-acting with spring, or piston double-acting with spring.
- *Valve Style*—Enter the valve style, rotary or sliding-stem
- *Zero Control Signal*—Identifies whether the valve is fully open or fully closed when the input is 0%. If you are unsure how to set this parameter, disconnect the current source to the instrument. The resulting valve travel is the Zero Control Signal. (With direct acting digital valve controllers, disconnecting the current source is the same as setting the output pressure to zero.)

## Setting Response

Field Communicator | Setup & Diag > Detailed Setup > Response Control (1-2-6)

Follow the prompts on the Field Communicator to configure the following response control parameters:

### **⚠ WARNING**

**Changes to the tuning set may cause the valve/actuator assembly to stroke. To avoid personal injury and property damage caused by moving parts, keep hands, tools, and other objects away from the valve/actuator assembly.**

---

- *Tuning Set*—There are eleven tuning sets to choose from. Each tuning set provides a preselected value for the digital valve controller gain settings. Tuning set C provides the slowest response and M provides the fastest response. Table 2-4 lists the proportional gain, velocity gain, and minor loop feedback gain values for preselected tuning sets.



Table 2-4. Gain Values for Preselected Turning Sets

Tuning Set	Proportional Gain	Velocity Gain	Minor Loop Feedback Gain
C	5	2	55
D	6	2	55
E	7	2	55
F	8	2	52
G	9	2	49
H	10	2	46
I	11	2	44
J	12	1	41
K	14	1	38
L	16	1	35
M	18	1	35

- *Damping Factor*—If after selecting a tuning set the valve travel overshoot is excessive or unsatisfactory, the damping factor allows you to either decrease damping to allow more overshoot, or increase damping to decrease the overshoot.
- *Expert Tuning Gains*—With Expert Tuning, you can specify the proportional gain, velocity gain, and minor loop feedback gain.
- *Input Char*—Defines the relationship between the travel target and ranged set point. Ranged set point is the input to the characterization function. If the zero control signal equals closed, then a set point of 0% corresponds to a ranged input of 0%. If the zero control signal equals open, a set point of 0% corresponds to a ranged input of 100%. Travel target is the output from the characterization function.

You can select from the three fixed input characteristics shown in figure 2-2 or you can select a custom characteristic. Figure 2-2 shows the relationship between the travel target and ranged set point for the fixed input characteristics, assuming the Zero Control Signal is configured as closed.

You can specify 21 points on a custom characteristic curve. Each point defines a travel target, in % of ranged travel, for a corresponding set point, in % of ranged set point. Set point values range from -6.25% to 106.25%. Before modification, the custom characteristic is linear.

With input characterization you can modify the overall characteristic of the valve and instrument combination. Selecting an equal percentage, quick opening, or custom (other than the default of linear) input characteristic modifies the overall valve and instrument characteristic. However, if you select the linear input characteristic, the overall valve and instrument characteristic is the characteristic of the valve, which is determined by the valve trim (i.e., the plug or cage).

- *Custom Char Table*—To define a custom input characteristic, select *Custom Char Table*. Select the point you wish to define (1 to 21), then enter the desired set point value. Press Enter then enter the desired travel target for the corresponding set point. When finished, select point 0 to return to the *Response Control* menu.

Figure 2-2. Travel Target Versus Ranged Set Point, for Various Input Characteristics (Zero Control Signal = Closed)

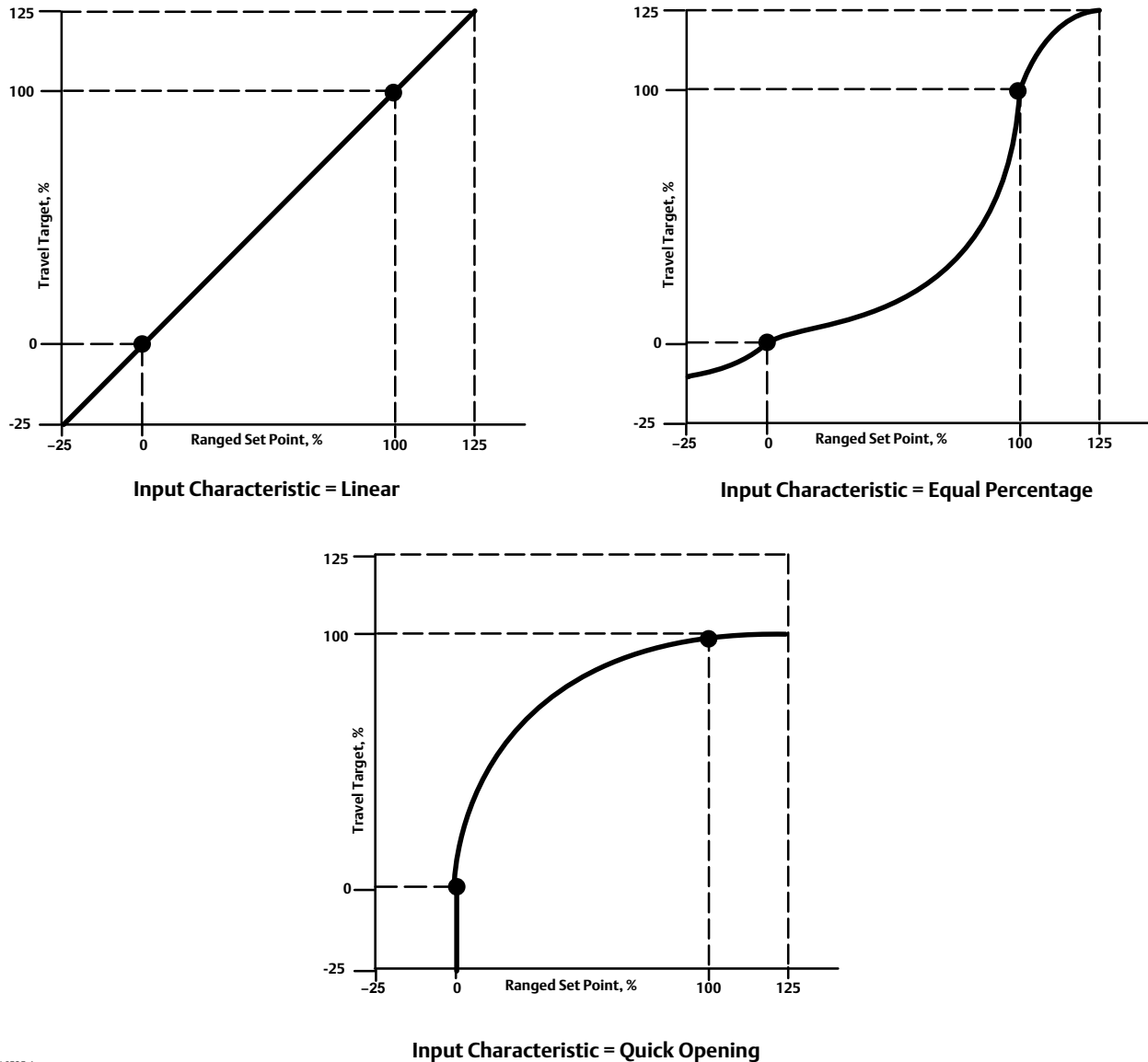

A6535-1

- **Setpt Filter Time**—Time constant for the set point filter, in seconds. The set point filter slows the response of the digital valve controller and is typically used with noisy or fast processes. The filter provides improved closed loop process control. To disable the filter, set the time constant to 0 seconds.

- **Limits and Cutoff**

**Travel Limit Hi**—Defines the high limit for the travel in percent (%) of ranged travel. It is the maximum allowable travel (in percent of ranged travel) for the valve. During operation, the travel target will not exceed this limit. When a Travel Limit High is set, the Travel Cutoff High is deactivated, since only one of these parameters can be active. Travel Limit High is deactivated by setting it to 125.0%.

*Travel Limit Lo*—Defines the low limit for the travel in percent (%) of ranged travel. It is the minimum allowable travel (in percent of ranged travel) for the valve. During operation, the travel target will not exceed this limit. When a Travel Limit Low is set, the Travel Cutoff Low is deactivated, since only one of these parameters can be active. Travel Limit Low is deactivated by setting it to -25.0%.

*Travel Cutoff Hi*—Defines the high cutoff point for the travel in percent (%) of ranged travel. Above this cutoff, the travel target is set to 123.0% of the ranged travel. When a Travel Cutoff High is set, the Travel Limit High is deactivated, since only one of these parameters can be active. Travel Cutoff High is deactivated by setting it to 125.0%.

*Travel Cutoff Lo*—Defines the low cutoff point for the travel. Travel Cutoff Low can be used to ensure proper seat load is applied to the valve. When below the travel cutoff low, the output is set to zero or to full supply pressure, depending upon the zero control signal. A Travel Cutoff Low of 0.5% is recommended to help ensure maximum shutoff seat loading.

When a Travel Cutoff Low is set, the Travel Limit Low is deactivated, since only one of these parameters can be active. Travel Cutoff Low is deactivated by setting it to -25.0%.

- Min Open/Close

*Min Opening Time*—Minimum Opening Time is configured in seconds and defines the minimum time for the travel to increase the entire ranged travel. This rate is applied to any travel increases. A value of 0.0 seconds deactivates this feature and allows the valve to stroke open as fast as possible. This parameter should be set to 0 in firmware 1, 2, 3, and 4.

*Min Closing Time*—Minimum Closing Time is configured in seconds and defines the minimum time for the travel to decrease the entire ranged travel. This rate is applied to any travel decreases. A value of 0.0 seconds deactivates this feature and allows the valve to stroke closed as fast as possible. This parameter should be set to 0 in firmware 1, 2, 3, and 4.

- Integral Settings

*Enab Int Control*—Select Yes or No

*Integral Gain*—By setting this value to 0.0 the positioner integrator is disabled. Any other value will provide reset action to improve static performance.

*Integral Dead Zone*—When the travel target and actual target deviate by less than this amount, the integrator is automatically disabled. This prevents the positioner integrator from fighting with the process controller integrator which may result in valve oscillation.

## Setting Alerts

Field Communicator
--------------------

Setup & Diag > Detailed Setup > Alerts (1-2-7)
--

The following menus are available for configuring Alerts. Items on the menus may be changed with the instrument In Service. Protection does not need to be removed (no need to set to *None*). Alerts are not processed when a Diagnostic is in progress. Follow the prompts on the Field Communicator display to configure alerts.

---

### Note

Alerts are not available with instrument level AC.

---

## Setting Travel Alerts

### Setting High, High-High, Low and Low-Low Alerts

Follow the prompts on the Field Communicator to set the following travel alerts:

- *Tvl Hi/Lo Enab*—Yes or No. Travel Hi/Lo Enable activates checking of the ranged travel against the Travel Alert High and Low Points. Travel Alert Hi is set if the ranged travel rises above the alert high point. Once the alert is set, the ranged travel must fall below the alert high point by the Travel Alert Deadband before the alert is cleared. See figure 2-3.

Travel Alert Lo is set if the ranged travel falls below the alert low point. Once the alert is set, the ranged travel must rise above the alert low point by the Travel Alert Deadband before the alert is cleared. See figure 2-3.

- *Tvl HH/LL Enab*—Yes or No. Travel HH/LL Enable activates checking of the ranged travel against the Travel Alert High-High and Low-Low Points. Travel Alert Hi Hi is set if the ranged travel rises above the alert high-high point. Once the alert is set, the ranged travel must fall below the alert high-high point by the Travel Alert Deadband before the alert is cleared. See figure 2-3.

Travel Alert Lo Lo is set if the ranged travel falls below the alert low-low point. Once the alert is set, the ranged travel must rise above the alert low-low point by the Travel Alert Deadband before the alert is cleared. See figure 2-3.

Figure 2-3. Travel Alert Deadband

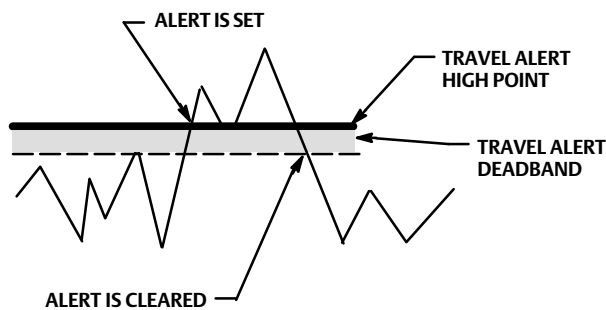

A6532

- *Tvl Alert Hi Pt*—Travel Alert High Point is the value of the travel, in percent (%) of ranged travel, which, when exceeded, sets the Travel Alert High alert.
- *Tvl Alert Lo Pt*—Travel Alert Low Point is the value of the travel, in percent (%) of ranged travel, which, when exceeded, sets the Travel Alert Low alert.
- *Tvl Alert Hi Hi Pt*—Travel Alert High-High Point is the value of the travel, in percent (%) of ranged travel, which, when exceeded, sets the Travel Alert Hi Hi alert.
- *Tvl Alert Lo Lo Pt*—Travel Alert Low-Low Point is the value of the travel, in percent (%) of ranged travel, which, when exceeded, sets the Travel Alert Lo Lo alert.

- *Tvl Alrt DB*—Travel Alert Deadband is the travel, in percent (%) of ranged travel, required to clear a travel alert, once it has been set. The deadband applies to both Travel Alert Hi/Lo and Travel Alert Hi Hi/Lo Lo. See figure 2-3.

---

**Note**

The Travel Alert Deadband applies to the Travel Deviation as well as Travel Alert Hi/Lo and Travel Alert Hi Hi/Lo Lo.

---

## Setting Travel Deviation Alert

Follow the prompts on the Field Communicator to set the following travel deviation alerts:

- *Tvl Dev Alrt Enab*—Yes or No. When enabled, checks the difference between the travel target and the actual travel. If the difference exceeds the Travel Deviation Alert Point for more than the Travel Deviation Time, the Travel Deviation Alert is set. It remains set until the difference between the travel target and the actual travel is less than the Travel Deviation Alert Point minus the Travel Alert Deadband.
- *Tvl Dev Alrt Pt*—Travel Deviation Alert Point is the alert point for the difference, expressed in percent (%), between the travel target and the actual travel. When the difference exceeds the alert point for more than the Travel Deviation Time, the Travel Deviation Alert is set.
- *Tvl Dev Time*—Travel Deviation Time is the time, in seconds, that the travel deviation must exceed the Travel Deviation Alert Point before the alert is set.

## Setting Travel Accumulation Alert

Follow the prompts on the Field Communicator to set the following travel accumulation alerts:

- *Tvl Accum Alrt Enab*—Yes or No. Travel Accumulator Alert Enable activates checking of the difference between the Travel Accumulator value and the Travel Accumulator Alert Point. The Travel Accumulator Alert is set when the Travel Accumulator value exceeds the Travel Accumulator Alert Point. It is cleared after you reset the Travel Accumulator to a value less than the alert point.
- *Tvl Accum Alrt Pt*—Travel Accumulator Alert Point is the value of the Travel Accumulator, in percent (%) of ranged travel, which, when exceeded, sets the Travel Accumulator Alert.
- *Tvl Accum DB*—Travel Accumulator Deadband is the area around the travel reference point, in percent (%) of ranged travel, that was established at the last increment of the accumulator. This area must be exceeded before a change in travel can be accumulated. See figure 2-4.
- *Tvl Accum*—Travel Accumulator records the total change in travel, in percent (%) of ranged travel, since the accumulator was last cleared. The value of the Travel Accumulator increments when the magnitude of the change exceeds the Travel Accumulator Dead- band. See figure 2-4. You can reset the Travel Accumulator by configuring it to zero.

Figure 2-4. Travel Accumulator Deadband (set at 10%)

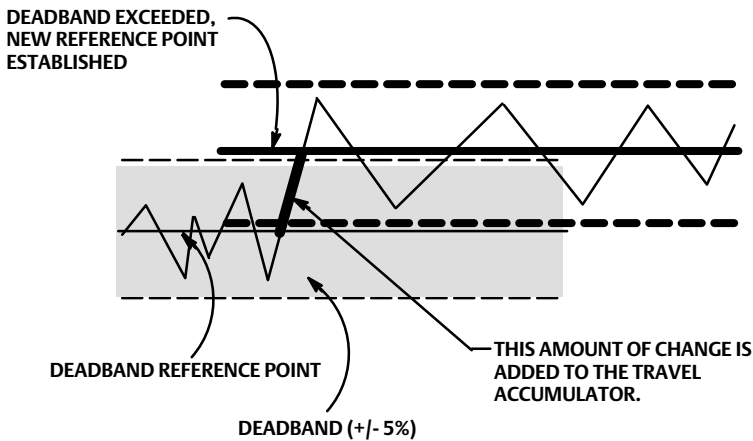

A6534

## Cycle Counter Alert

Follow the prompts on the Field Communicator to set the following cycle counter alerts:

- *Cycl Cnt Alrt Enab*—Yes or No. Cycle Counter Alert Enable activates checking of the difference between the Cycle Counter and the Cycle Counter Alert point. The Cycle Counter Alert is set when the value exceeds the Cycle Counter Alert point. It is cleared after you reset the Cycle Counter to a value less than the alert point.
- *Cycl Cnt Alrt Pt*—Cycle Counter Alert Point is the value of the Cycle Counter, in cycles, which, when exceeded, sets the Cycle Counter Alert.
- *Cycle Count DB*—Cycle Counter Deadband is the area around the travel reference point, in percent (%) of ranged travel, that was established at the last increment of the Cycle Counter. This area must be exceeded before a change in travel direction can be counted as a cycle. See figure 2-5.

Figure 2-5. Cycle Counter Deadband (set at 10%)

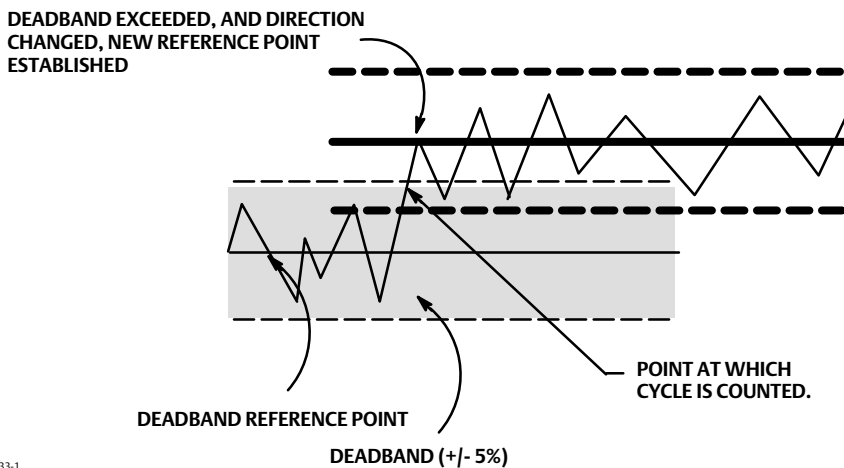

A6533-1

- *Cycle Count*—Cycle Counter records the number of times the travel changes direction. The change in direction must occur after the deadband has been exceeded before it can be counted as a cycle. See figure 2-5. You can reset the Cycle Counter by configuring it as zero.

## Other Alerts

Follow the prompts on the Field Communicator to configure Drive Alert Enable:

- *Drive Alert Enab*—Yes or No. Drive Alert Enable activates checking of the relationship between the Drive Signal and the calibrated travel. If one of the following conditions exists for more than 20 seconds, the Drive Alert is set.

For the case where Zero Control Signal is defined as closed:

Drive Signal < 10% and Calibrated Travel > 3%

Drive Signal > 90% and Calibrated Travel < 97%

For the case where Zero Control Signal is defined as open:

Drive Signal < 10% and Calibrated Travel < 97%

Drive Signal > 90% and Calibrated Travel > 3%

## Alert Record

The alert record can store up to 20 alerts from any of the enabled alert groups: Valve Alerts, Failure Alerts, or Miscellaneous Alerts. Starting from a cleared database, the first 20 alerts that become active will be stored in memory.

Follow the prompts on the Field Communicator to set or display the following:

- *Display Record*—Displays all recorded alerts and the date and time the alerts were recorded.
- *Clear Record*—Clears the alert record. To clear the alert record, all alerts in enabled groups must be inactive.
- *Inst Date & Time*—Permits setting the instrument clock. When alerts are stored in the alert record, the date and time (obtained from the instrument clock) that they were stored is also stored in the record. The instrument clock uses a 24-hour format. Enter the date and time in the form: MM/DD/YYYY HH:MM:SS, where MM is two digits for the month (1 through 12), DD is two digits for the day (1 through 31), and YYYY is four digits for the year (1980 through 2040), HH is two digits for the hour (00 to 23), MM is two digits for the minutes (00 to 59), and SS is two digits for the seconds (00 through 59).
- *Record Group Enab*—Permits enabling one or more alert groups. Table 3-2 lists the alerts included in each of the groups. When any alert from an enabled group becomes active, active alerts in all enabled groups are stored.

## Self Test Failures for Instrument Shutdown

Field Communicator	Setup & Diag > Detailed Setup > Self Test Shutdown (1-2-8)
--------------------	--

Upon shutdown, the instrument attempts to drive its output pressure to the zero current condition and no longer executes its control function. In addition, the appropriate failure statuses are set. Once the problem that caused the shutdown has been fixed, the instrument can be restarted by cycling the power or selecting Restart from the *Mode* menu of the Field Communicator. Also see the Viewing Instrument Status section on page 35 for further details about failures.

Follow the prompts on the Field Communicator display to determine the self test shutdown criteria from the following:

- *Done*—Select this if you are done modifying the self test shutdown criteria.
- *Flash ROM Fail*—When enabled, the instrument shuts down whenever there is a failure associated with flash ROM (read only memory).
- *Temp Comp Fail*—When enabled, the instrument shuts down whenever this is a failure associated with Temperature Compensation.
- *Ref Voltage Fail*—When enabled, the instrument shuts down whenever there is a failure associated with the internal voltage reference.
- *Drive Current Fail*—When enabled, the instrument shuts down whenever the drive current does not read as expected.
- *NVM Fail*—When enabled, the instrument shuts down whenever there is a failure associated with NVM (non-volatile memory).
- *Temp Sensor Fail*—When enabled, the instrument shuts down whenever there is a failure associated with the internal temperature sensor.
- *Press Sensor Fail*—When enabled, the instrument shuts down whenever there is a failure associated with the pressure sensor.
- *Travel Sensor Fail*—When enabled, the instrument shuts down whenever there is a failure associated with the travel sensor.



## Transmitter/Switches

Field Communicator

Setup &amp; Diag &gt; Detailed Setup &gt; Transmitter/Switches (1-2-9)

---

### Note

These menu items are only available on units that have the optional position transmitter / limit switch hardware installed.

If optional limit switches are being used, power must be applied to the switch circuits throughout the calibration routine. Failure to power the switches may result in incorrect switch orientation.

---

Follow the prompts on the Field Communicator display to configure the following:

- *Switch 1 Trip Point*—Defines the threshold for the limit switch wired to terminals +41 and -42 in percent of calibrated travel.
- *Switch 1 Closed*—Configures the action of the limit switch wired to terminals +41 and -42. Selecting ABOVE configures the switch to be closed when the travel is above the trip point. Selecting BELOW configures the switch to be closed when the travel is below the trip point. Selecting DISABLED removes the icons and status from the display.
- *Switch 2 Trip Point*—Defines the threshold for the limit switch wired to terminals +51 and -52 in percent of calibrated travel.
- *Switch 2 Closed*—Configures the action of the limit switch wired to terminals +51 and -52. Selecting ABOVE travel is above the trip point. Selecting BELOW configures the switch to be closed when the travel is below the trip point. Selecting DISABLED removes the icons and status from the display.

---

### Note

Switch #2 is only operational if power is applied to switch #1 also. Switch #2 cannot be used alone.

---

- *Transmitter Action*—This configures the relationship between the valve travel and the position transmitter output signal. If you select CLOSED, the transmitter will send 4 mA when the valve is closed. If you select OPEN, the transmitter will send 4 mA when the valve is open.

A switch is located on the options board to select the transmitter fail signal (high+ or low-). High+ will result in a current output of > 22.5 mA upon transmitter failure. Low- will result in a current output of < 3.6 mA. Refer to figure 2-6 for location and switch selection.

Figure 2-6. XMTR Switch

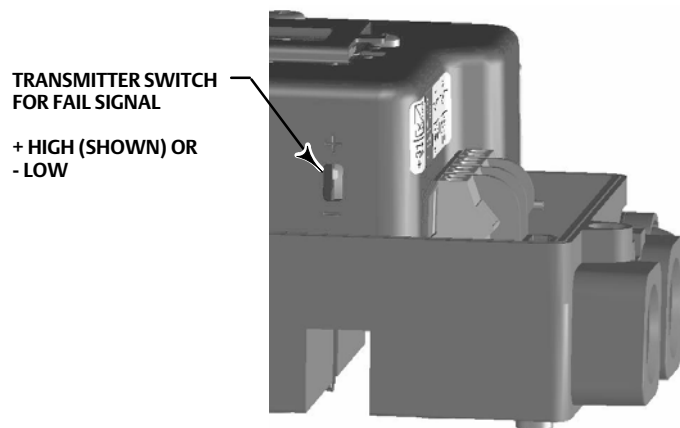

## Tuning

### **⚠ WARNING**

Changes to the tuning set may cause the valve/actuator assembly to stroke. To avoid personal injury and property damage caused by moving parts, keep hands, tools, and other objects away from the valve/actuator assembly.

## Automatic

Field Communicator	Calibrate > Calibrate > Auto Tuner (1-4-5)
--------------------	--

The auto tuner is used to optimize digital valve controller tuning. It can be used on most sliding-stem and rotary designs, including Fisher and other manufacturers' products. Moreover, because the auto tuner can detect internal instabilities before they become apparent in the travel response, it can generally optimize tuning more effectively than manual tuning.

## Manual

If the auto tuner does not provide the desired responsiveness, you can manually tune the DVC2000. Refer to Setting Response, page 16.

# Calibration

Field Communicator

Calibrate &gt; Calibrate (1-4)

## ⚠ WARNING

During calibration the valve will move full stroke. To avoid personal injury and property damage caused by the release of pressure or process fluid, isolate the valve from the process and equalize pressure on both sides of the valve or bleed off the process fluid.

### Note

If optional limit switches are being used, power must be applied to the switch circuits throughout the calibration routine. Failure to power the switches may result in incorrect switch orientation.

## Analog Input Calibration

The DVC2000 digital valve controller is shipped from the factory with the analog input already calibrated. You do not normally need to perform this procedure. However, if you suspect that this needs adjustment, follow one of the procedures below.

### Using the Field Communicator to perform Analog Input Calibration

To calibrate the analog input sensor, connect a variable current source to the instrument LOOP+ and LOOP- terminals. The current source should be capable of generating an output of 4 to 20 mA. Select *Analog In Calib* from the *Calibrate* menu, then follow the prompts on the Field Communicator display to calibrate the analog input sensor.

1. Set the current source to the target value shown on the display. The target value is the Input Range Low value. Press OK.
2. The following message appears:

Use Increase and  
Decrease selections  
until the displayed  
current matches the  
target.

Press OK when you have read this message.

3. The value of the Analog Input appears on the display. Press OK to display the adjustment menu.
4. From the adjustment menu, select the direction and size of adjustment to the displayed value. Selecting large, medium, and small adjustments causes changes of approximately 0.4 mA, 0.04 mA, and 0.004 mA, respectively. If the displayed value does not match the current source, press OK, then repeat this step (step 4) to further adjust the displayed value. When the displayed value matches the current source, select Done and go to step 5.
5. Set the current source to the target value shown on the display. The target value is the Input Range High value. Press OK.

6. The following message appears:

Use Increase and Decrease selections until the displayed current matches the target.

Press OK when you have read this message.

7. The value of the Analog Input appears on the display. Press OK to display the adjustment menu.
8. From the adjustment menu, select the direction and size of adjustment to the displayed value. Selecting large, medium, and small adjustments causes changes of approximately 0.4 mA, 0.04 mA, and 0.004 mA, respectively. If the displayed value does not match the current source, press OK, then repeat this step (step 8) to further adjust the displayed value. When the displayed value matches the current source, select Done and go to step 9.
9. Place the instrument In Service and verify that the analog input displayed matches the current source.

---

**Note**

Analog Input Calibration can also be performed using the Local Operator Interface, as described in the procedure below.

---

## Using the Local Operator Interface to perform Analog Input Calibration

Refer to step 6 of the Local Interface Flow Chart on page 58 of this manual.

Connect a variable current source to the instrument +11 and -12 terminals. From the home screen, press the DOWN (▼) arrow key five times and then press the RIGHT (▶) arrow key. Acknowledge the warning if you are sure that you want to proceed.

1. Adjust the variable current source to 4 mA.
2. Press the RIGHT (▶) arrow key
3. Adjust the variable current source to 20 mA.
4. Press the RIGHT (▶) arrow key.

If you want to keep this calibration, select SAVE AND EXIT. If you exit without saving, the last saved configuration data will be restored.

## Auto Calibrate Travel

1. The auto calibration procedure is automatic. It is completed when the *Calibrate* menu appears.

During calibration, the instrument seeks the high and low end points and the minor loop feedback (MLFB) and output bias. By searching for the end points, the instrument establishes the limits of physical travel, i.e., the actual travel 0 and 100% positions. This also determines how far the relay beam swings to calibrate the sensitivity of the beam position sensor.

Adjusting the minor loop feedback bias is done around mid travel. The valve position is briefly moved back and forth to determine the relay beam position at quiescence. Essentially, it establishes the zero point for the Minor Loop Feedback circuit. The back and forth motion is performed to account for hysteresis.

Adjusting the output bias aligns the travel set point with the actual travel by computing the drive signal required to produce 0% error. This is done while the valve is at 50% travel, making very small adjustments.

2. Place the instrument In Service and verify that the travel properly tracks the current source.

## Manual Calibrate Travel

Two procedures are available to manually calibrate travel:

- Analog Adjust
- Digital Adjust

### Analog Calibration Adjust

Connect a variable current source to the instrument LOOP + and LOOP - terminals. The current source should be capable of generating 4 to 20 mA. Follow the prompts on the Field Communicator display to calibrate the instrument's travel in percent.

---

**Note**

0% Travel = Valve Closed  
100% Travel = Valve Open

---

1. Adjust the input current until the valve is near mid-travel. Press OK.

---

**Note**

In steps 2 through 4, the accuracy of the current source adjustment affects the position accuracy.

---

2. Adjust the current source until the valve is at 0% travel, then press OK.
3. Adjust the current source until the valve is at 100% travel, then press OK.
4. Adjust the current source until the valve is at 50% travel, then press OK.
5. Place the instrument In Service and verify that the travel properly tracks the current source.

### Digital Calibration Adjust

Connect a variable current source to the instrument LOOP + and LOOP - terminals. The current source should be set between 4 and 20 mA. Follow the prompts on the Field Communicator display to calibrate the instrument's travel in percent.

---

**Note**

0% Travel = Valve Closed  
100% Travel = Valve Open

---

1. From the adjustment menu, select the direction and size of change required to set the travel at 0%.  
If another adjustment is required, repeat step 1. Otherwise, select Done and go to step 2.
2. From the adjustment menu, select the direction and size of change required to set the travel to 100%.  
If another adjustment is required, repeat step 2. Otherwise, select Done and go to step 3.
3. From the adjustment menu, select the direction and size of change required to set the travel to 50%.  
If another adjustment is required, repeat step 3. Otherwise, select Done and go to step 4.
4. Place the instrument In Service and verify that the travel properly tracks the current source.

## Pressure Sensor Calibration

---

### Note

The pressure sensor is calibrated at the factory and should not require calibration.

---

## Output Pressure Sensor Calibration

To calibrate the output pressure sensor, connect an external reference gauge to the output being calibrated. The gauge should be capable of measuring maximum instrument supply pressure. From the *Calibrate* menu, select *Pressure Calib*. Follow the prompts on the Field Communicator display to calibrate the instrument's output pressure sensor.

1. Adjust the supply pressure regulator to the maximum instrument supply pressure. Press OK.
2. The instrument reduces the output pressure to 0. The following message appears.

Use the Increase and Decrease selections until the displayed pressure matches the output x pressure.

Press OK when you have read the message.

3. The value of the output pressure appears on the display. Press OK to display the adjustment menu.
4. From the adjustment menu, select the direction and size of adjustment to the displayed value. Selecting large, medium, and small adjustments causes changes of approximately 3.0 psi/0.207 bar/20.7 kPa, 0.30 psi/0.0207 bar/2.07 kPa, and 0.03 psi/0.00207 bar/0.207 kPa, respectively. If the displayed value does not match the output pressure, press OK, then repeat this step (step 4) to further adjust the displayed value. When the displayed value matches the output pressure, select Done and go to step 5.
5. The instrument sets the output pressure to full supply. The following message appears.

Use the Increase and Decrease selections until the displayed pressure matches the output x pressure.

Press OK when you have read the message.

6. The value of the output pressure appears on the display. Press OK to display the adjustment menu.
7. From the adjustment menu, select the direction and size of adjustment to the displayed value. Selecting large, medium, and small adjustments causes changes of approximately 3.0 psi/0.207 bar/20.7 kPa, 0.30 psi/0.0207 bar/2.07 kPa, and 0.03 psi/0.00207 bar/0.207 kPa, respectively. If the displayed value does not match the output pressure, press OK, then repeat this step (step 7) to further adjust the displayed value. When the displayed value matches the output pressure, select Done and go to step 8.
8. Place the instrument In Service and verify that the displayed pressure matches the measured output pressure.

## Position Transmitter Calibration

---

### Note

The position transmitter is calibrated at the factory and should not require calibration.

---

### Note

This procedure will not move the control valve. The instrument will simulate an output for calibration purposes only.

---

This procedure is only available on units that have the optional position transmitter / limit switch hardware installed. The DVC2000 digital valve controller is shipped from the factory with the position transmitter already calibrated.

To calibrate the position transmitter, select *Transmitter Calibration* from the *Calibrate* menu. Connect a current meter in series with the +31 and -32 terminals, and a voltage source (such as the DCS analog input channel). Follow the prompts on the Field Communicator display to manipulate the output current read by the current meter to 4 mA, and then to 20 mA.





## Section 3 Viewing Device Variables and Diagnostics

### Viewing Variables

---

**Note**

These variables are not available for instrument level AC.

---

### Analog Input, Travel, Valve Set Point, Drive Signal and Output Pressure

The following variables are displayed on the Online menu:

**Analog In** shows the value of the instrument analog input in mA (milliamperes) or % (percent) of ranged input.

**Travel** shows the value of the DVC2000 digital valve controller travel in % (percent) of ranged travel. Travel always represents how far the valve is open.

**Valve SP** shows the requested valve position in % of ranged travel.

**Drive Sgl** shows the value of the instrument drive signal in % (percent) of maximum drive.

**Pressure** shows the value of the instrument output pressure in psi, bar, or kPa.

### Additional Instrument Variables

Field Communicator	Setup & Diag > Display > Variables (1-3-1)
--------------------	--

---

**Note**

These variables are not available for instrument level AC.

---

The *Variables* menu is available to view additional variables, such as the status of the auxiliary input, the instrument internal temperature, cycle count, travel accumulation and device free time. If a value for a variable does not appear on the display, select the variable and a detailed display of that variable with its value will appear. A variable's value does not appear on the menu if the value becomes too large to fit in the allocated space on the display, or if the variable requires special processing.

- *Temp*—The internal temperature of the instrument is displayed in either degrees Fahrenheit or Celsius.
- *Cycl Count*—Cycle Counter displays the number of times the valve travel has cycled. Only changes in direction of the travel after the travel has exceeded the deadband are counted as a cycle. Once a new cycle has occurred, a new deadband around the last travel is set. The value of the Cycle Counter can be reset from the *Cycle Count Alert* menu.

- *Tvl Accum*—Travel Accumulator contains the total change in travel, in percent of ranged travel. The accumulator only increments when travel exceeds the deadband. Then the greatest amount of change in one direction from the original reference point (after the deadband has been exceeded) will be added to the Travel Accumulator. The value of the Travel Accumulator can be reset from the *Travel Accum Alert* menu.

## Viewing Device Information

Field Communicator	Setup & Diag > Display > Device Information (1-3-2)
--------------------	---

The *Device Information* menu is available to view information about the instrument.

Follow the prompts on the Field Communicator display to view information in the following fields:

- *HART Univ Rev*—HART Universal Revision is the revision number of the HART Universal Commands which are used as the communications protocol for the instrument.
- *Device Rev*—Device Revision is the revision number of the software for communication between the Field Communicator and the instrument.
- *Firmware Rev*—Firmware Revision is the revision number of the Fisher firmware in the instrument.
- *Firmware Date*—Firmware Date is the revision date of the firmware being used.
- *Main Elec Rev*—Main Electronics Revision is the revision number of the main electronics component.
- *Sec Elec Rev*—Secondary Electronics Revision is the revision number of the secondary electronics component.
- *Sensor Serial Num*—Sensor Serial Number is the serial number of the sensor
- *Inst Level*—Indicates the instrument level
  - AC—Auto Calibrate
  - HC—HART Communicating
  - AD—Advanced Diagnostics
  - PD—Performance Diagnostic

Table 3-1 lists the functions available for each instrument level.

Table 3-1. Functions Available for Instrument Level

Instrument Level	Functions Available
AC	Communicates via the LCD or with Field Communicator. Provides basic setup and calibration.
HC	Communicates via the LCD, the Field Communicator and ValveLink Software. Provides basic setup, calibration, travel cutoffs and limits, minimum opening and closing times, input characterization (linear, equal percentage, quick opening, and custom) and the following alerts: travel deviation; travel alert high, low, high high, and low low; drive signal; auxiliary terminal; cycle counter; and travel accumulation.
AD	Includes all functions listed above plus (with ValveLink software) all offline diagnostic tests (dynamic error band, drive signal, step response, and valve signature) plus online trending
PD	Includes all functions listed above plus online valve signature test (friction analysis)

- *Device ID*—Each instrument has a unique Device Identifier. The device ID provides additional security to prevent this instrument from accepting commands meant for other instruments.

## Viewing Instrument Status

Field Communicator	Instrument Status (7)
--------------------	-----------------------

---

**Note**

Instrument Status is not available for instrument level AC.

---

The following describes the various displays for the Instrument Status menu.

- **Done**—Select this when you are done viewing the instrument status.

---

**Note**

Alerts are not available with instrument level AC.

---

- **Valve Alerts**—If a valve alert is active, it will appear when the Valve Alerts menu item is selected. If more than one alert is active, they will appear on the display one at a time in the order listed below.
  1. Alert Record has Entries
  2. Alert Record is full
  3. Instrument Time is Invalid
  4. Tvl Accumulation Alert
  5. Cycle Counter Alert
  6. Non-critical NVM Alert
  7. Power Starvation Alert
  8. Drive Signal Alert
  9. Tvl Lim/Cutoff Low
  10. Tvl Lim/Cutoff High
  11. Tvl Deviation Alrt
  12. Tvl Alert Hi Hi
  13. Tvl Alert Hi
  14. Tvl Alert Lo Lo
  15. Tvl Alert Lo

- **Failure Alerts**—If a self-test failure has occurred, it will appear when the Failure Alerts menu item is selected. If there are multiple failures, they will appear on the display one at a time in the order listed below.
  1. *Offline/Failed*—This failure indicates a failure, enabled from the Self Test Shutdown menu, caused an instrument shutdown. Press Enter to see which of the specific failures caused the Offline/Failed indication.
  2. *Travel Sensor Fail*—This failure indicates the sensed travel is outside the range of -25.0 to 125.0% of calibrated travel. If this failure is indicated, check the instrument mounting.
  3. *Pressure Sensor Fail*—This failure indicates the actuator pressure is outside the range of -24.0 to 125.0% of the calibrated pressure for more than 60 seconds. If this failure is indicated, check the instrument supply pressure. If the failure persists, ensure the printed wiring board assembly is properly mounted onto the mounting frame, and the pressure sensor O-rings are properly installed. If the failure does not clear after restarting the instrument, replace the printed wiring board assembly.
  4. *Temperature Sensor Fail*—This failure is indicated when the instrument temperature sensor fails, or the sensor reading is outside of the range of -40 to 85°C (-40 to 185°F). The temperature reading is used internally for temperature compensation of inputs. If this failure is indicated, restart the instrument and see if it clears. If it does not clear, replace the printed wiring board assembly.
  5. *NVM Fail*—This failure is indicated when the Non-Volatile Memory integrity test fails. Configuration data is stored in NVM. If this failure is indicated, restart the instrument and see if it clears. If it does not clear, replace the printed wiring board Assembly.
  6. *Drive Current Fail*—This failure is indicated when the drive current does not read as expected. If this failure occurs, check the connection between the I/P converter and the printed wiring board assembly. Try removing the I/P converter and re-installing it. If the failure does not clear, replace the I/P converter or the printed wiring board assembly.
  7. *Ref Voltage Fail*—This failure is indicated whenever there is a failure associated with the internal voltage reference. If this failure is indicated, restart the instrument and see if it clears. If it does not clear, replace the printed wiring board assembly.
  8. *Flash ROM Fail*—This failure indicates the Read Only Memory integrity test failed. If this failure is indicated, restart the instrument and see if it clears. If it does not clear, replace the printed wiring board assembly.
- **Alert Record**—The instrument contains an alert record that can store up to 20 alerts from any of the enabled alert groups: Valve Alerts or Failure Alerts. See the Advanced Setup section for information on enabling alert groups. Table 3-2 lists the alerts included in each of the groups. The alert record also includes the date and time (from the instrument clock) the alerts occurred.

Table 3-2. Alerts Included in Alert Groups for Alert Record

Alert Group	Alerts Included in Group
Valve Alerts	Travel Alert Lo Travel Alert Hi Travel Alert Lo Lo Travel Alert Hi Hi Travel deviation Drive signal
Failure Alerts	Flash ROM Shutdown Drive Current Shutdown Reference Voltage Shutdown Critical NVM Shutdown Temperature Sensor Shutdown Pressure Sensor Shutdown Travel Sensor Shutdown

- **Operational Status**—This menu item indicates the status of the Operational items listed below. The status of more than one operational may be indicated. If more than one Operational status is set, they will appear on the display one at a time in the order listed below.
  1. Out of Service
  2. Auto Calibration in Progress
  3. Input Char Selected
  4. Custom Char Selected
  5. Diagnostic in Progress
  6. Calibration in Progress
  7. Set Point Filter Active



## Section 4 Maintenance and Troubleshooting

The DVC2000 digital valve controller has the capability to provide predictive maintenance information through the use of ValveLink software. This software allows you to pinpoint instrument and valve problems without disrupting the process. For information on using ValveLink software, see the ValveLink software quick start guide ([D102813X012](#)).

### **⚠ WARNING**

Avoid personal injury or property damage from sudden release of process pressure or bursting of parts. Before performing any maintenance procedures on the the DVC2000 digital valve controller:

- Always wear protective clothing, gloves, and eyewear when performing any maintenance procedures to avoid personal injury or property damage.
- Do not remove the actuator from the valve while the valve is still pressurized.
- Disconnect any operating lines providing air pressure, electric power, or a control signal to the actuator. Be sure the actuator cannot suddenly open or close the control valve.
- Use bypass valves or completely shut off the process to isolate the control valve from process pressure. Relieve process pressure from both sides of the control valve.
- Use lock-out procedures to be sure that the above measures stay in effect while you work on the equipment.
- Check with your process or safety engineer for any additional measures that must be taken to protect against process media.
- Vent the pneumatic actuator loading pressure and relieve any actuator spring precompression so the actuator is not applying force to the valve stem; this will allow for the safe removal of the stem connector.

### **CAUTION**

When replacing components, use only components specified by the factory. Always use proper component replacement techniques, as presented in this manual. Improper techniques or component selection may invalidate the approvals and the product specifications, as indicated in table 1-1 and may also impair operations and the intended function of the device.

## Stroking the Digital Valve Controller Output

Field Communicator	Setup & Diag > Stroke Valve (1-5)
--------------------	-----------------------------------

### **Note**

Stroke Valve is not available with instrument level AC.

Follow the prompts on the Field Communicator display to select from the following: *Done*, *Ramp Open*, *Ramp Closed*, *Ramp to Target*, and *Step to Target*, and *Stop*.

- *Done*—Select this if you are done. All ramping is stopped when DONE is selected.
- *Ramp Open*—ramps the travel toward open at the rate of 1.0% per second of the ranged travel.
- *Ramp Closed*—ramps the travel toward closed at the rate of 1.0% per second of the ranged travel.
- *Ramp to Target*—ramps the travel to the specified target at the rate of 1.0% per second of the ranged travel.
- *Step to Target*—steps the travel to the specified target.
- *Stop*—stops the command.

## Replacing the Instrument

To replace an instrument that has been previously mounted to a control valve, perform the following basic steps:

### Instrument Removal

1. Make sure that the valve is isolated from the process.
2. Remove the instrument cover (refer to figure 4-1).

Figure 4-1. FIELDVUE DVC2000 Exploded View

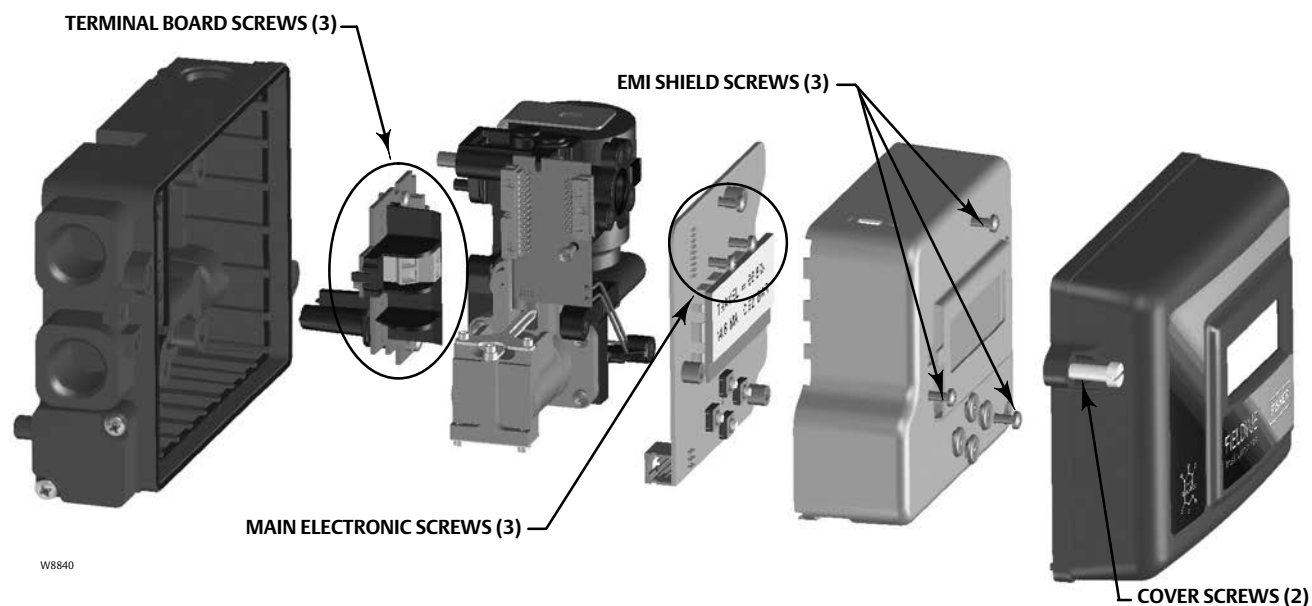

3. Disconnect the field wiring from the terminal board.
4. Shut off the instrument air supply and disconnect the tubing to the supply port.
5. Disconnect the tubing from the output port.



6. Remove the bolts connecting the DVC2000 housing to the mounting bracket.

---

**Note**

The magnet assembly may remain on the valve stem (or shaft).

---

When replacing the instrument, be sure to follow the mounting procedure outlined in the quick start guide ([D103203X012](#)) that shipped with the digital valve controller. Once the instrument is mounted, perform the Quick Setup routine outlined in the quick start guide. If changes need to be made to the default settings, use Detailed Setup to make the appropriate modifications.

## Replacing the Magnetic Feedback Assembly

To remove the magnet assembly from the actuator stem, perform the following basic steps.

1. Make sure that the valve is isolated from the process.
2. Remove the instrument cover.
3. Disconnect the field wiring from the terminal board.
4. Shut off the instrument air supply.
5. Remove the DVC2000 from the actuator.
6. Remove the screws holding the magnet assembly to the connector arm.

When replacing the instrument, be sure to follow the mounting procedure outlined in the quick start guide that shipped with the digital valve controller. Once the instrument is mounted, perform the Quick Setup routine outlined in the quick start guide. If changes need to be made to the default settings, use Detailed Setup to make the appropriate modifications.

## Component Replacement

When replacing any of the components of the DVC2000, the maintenance should be performed in an instrument shop whenever possible. Make sure that the electrical wiring and pneumatic tubing is disconnected prior to disassembling the instrument.

### CAUTION

**When replacing components, proper means of electrostatic discharge protection is required. Failure to use a grounding strap, or other means of electrostatic discharge protection can result in damage to the electronics.**

---

## Replacing the I/P Converter

The I/P converter is fastened to the mounting frame. On the I/P mounting surface is a replaceable screen with O-ring seal.

**Note**

After I/P converter replacement, calibrate the digital valve controller to maintain accuracy specifications.

**Removal**

1. Remove the main cover.
2. Remove three screws that hold the EMI shield and remove the shield (refer to figure 4-1).
3. Remove the three screws holding the electronics board to the mounting frame.
4. Pull the main electronics straight off of the mounting frame. The board is electrically connected to an interconnecting board with a rigid connector.
5. Remove the two screws holding the mounting frame to the instrument housing (refer to figure 4-2 for location of screws).

Figure 4-2. Mounting Frame Assembly

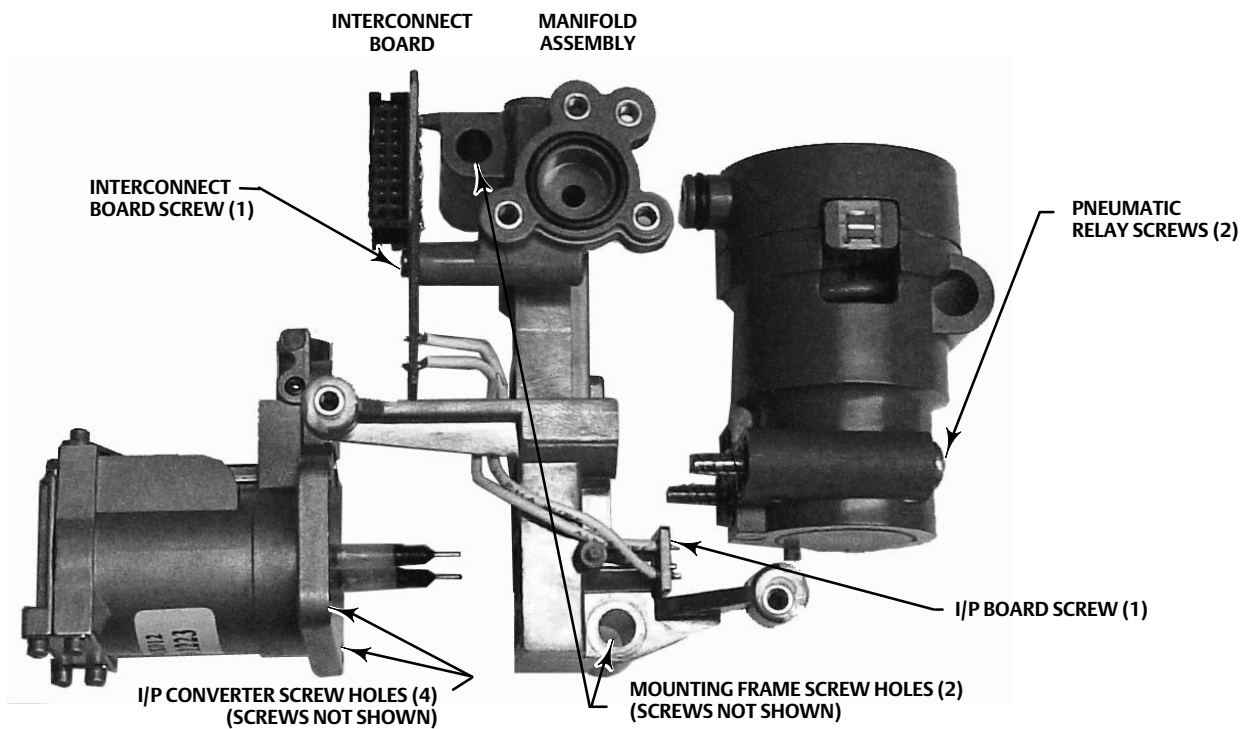

6. Pull the manifold assembly straight out. The interconnecting board is electrically connected to the termination board with a rigid connector.
7. Remove the interconnect board from the mounting frame.
8. Remove the four screws holding the I/P converter to the mounting frame (refer to figure 4-2 for location of screws).
9. Pull the I/P converter straight out taking care to capture the two o-rings (one has a screen).

## Assembly

When installing a new I/P converter, follow the reverse procedure as outlined above and recalibrate the instrument.

1. Install the I/P converter, making sure the screen O-ring is installed on the I/P supply port (the circular port on the mounting frame), and that the two manifold O-rings are in place.
2. Install the interconnect board on the mounting frame. Do not tighten the self-tapping screw on the interconnect board at this time (see figure 4-2).
3. Replace the manifold assembly.
4. Install the mounting frame to the housing, making sure that the O-rings (keys 45 and 51) are in place.
5. Install the main electronics to the mounting frame, making sure that the pressure sensor seal (key 16) is in place.
6. Tighten the self-tapping screw on the Interconnect Board.
7. Install the primary shield (key 37) with three screws.
8. Recalibrate the instrument and install the cover.

## Replacing the Pneumatic Relay

The pneumatic relay is fastened to the mounting frame. There are two versions, 0 to 3.4 bar (0 to 49 psig), indicated by a white label, and 3.5 to 7 bar (50 to 100 psig), indicated by a green label.

---

### Note

After pneumatic relay replacement, calibrate the digital valve controller to maintain accuracy specifications.

---

## Removal

1. Remove the main cover.
2. Remove three screws that hold the EMI shield and remove the shield (refer to figure 4-1).
3. Remove the three screws holding the electronics board to the mounting frame.
4. Pull the main electronics straight off of the mounting frame. The board is electrically connected to an interconnecting board with a rigid connector.
5. Remove the two screws holding the mounting frame to the instrument housing (refer to figure 4-2).
6. Pull the mounting frame straight out. The interconnecting board is electrically connected to the termination board with a rigid connector.
7. Remove the two screws holding the pneumatic relay to the mounting frame.
8. Pull the pneumatic relay straight out.

## Assembly

When installing a new pneumatic relay, follow the reverse procedure as outlined above and recalibrate the instrument.

# Troubleshooting

## What is a healthy unit?

In order to troubleshoot the DVC2000 digital valve controller, it is critical to understand how a healthy unit is supposed to behave. Below is a list of behaviors you should see if the instrument is performing well.

- LCD correctly displaying characters
- Pushbuttons allow navigation
- Valve travels full stroke
- No diagnostics messages
- No alerts or alarms
- Hall sensor within the valid range of travel on the magnet array
- Slight audible air venting
- Minimal overshoot
- Quick response
- Functionality matches the tier level

## What are the observable symptoms?

The next thing to do is to identify the symptoms of the unhealthy unit. Are there any obvious discrepancies that can be identified? Work through the following items to help gather information about the faulty behavior and identify the core problem(s). Also see the DVC2000 Troubleshooting Checklist on page 47.

1. Check the relay pressure range.

There are two available relays for the DVC2000:

- Low pressure: 0-3.4 bar (0-49 psi) — white label
- High pressure: 3.5-7 bar (50-100 psi) — green label

The supply pressure feeding the instrument must fall within the rated pressure range of the installed relay for proper operation.

2. Check the instrument protection (LCD via pushbuttons and Configure/Calibrate via HART)
3. Check for local device diagnostic messages

4. Check the alerts via HART
5. Check the feedback setup

Is the pole piece on the DVC2000 housing within the valid travel range of the feedback array?

6. Observe the stem movement and pressure delivery

### **Determine the logical causes.**

With the discrepancies identified, logic can now be applied to isolate the component that is in need of repair or replacement. There are seven main categories of problems:

1. Wiring and Terminations
2. Air Supply
3. Electronics
4. Firmware
5. Pneumatics
6. Travel feedback
7. Mounting

### **Repair or replace the faulty components.**

By isolating the problem to one of these categories, component replacement or repair becomes simple and straightforward. Refer to component replacement instructions earlier in this section.

## Checking Voltage Available

### ⚠ WARNING

Personal injury or property damage caused by fire or explosion may occur if this test is attempted in any area which contains a potentially explosive atmosphere or has been classified as hazardous.

To check the Voltage Available at the instrument, perform the following:

1. Disconnect the field wiring from the control system and connect equipment as shown in figure 4-3 to the control system terminals.”
2. Set the control system to provide maximum output current.
3. Set the resistance of the 1 kilOhm potentiometer shown in figure 4-3 to zero.
4. Record the current shown on the milliammeter.
5. Adjust the resistance of the 1 kilOhm potentiometer until the voltage read on the voltmeter is 9.0 Volts.
6. Record the current shown on the milliammeter.
7. If the current recorded in step 6 is the same as that recorded in step 4 ( $\pm 0.08$  mA), the voltage available is adequate.

Figure 4-3. Voltage Test Schematic

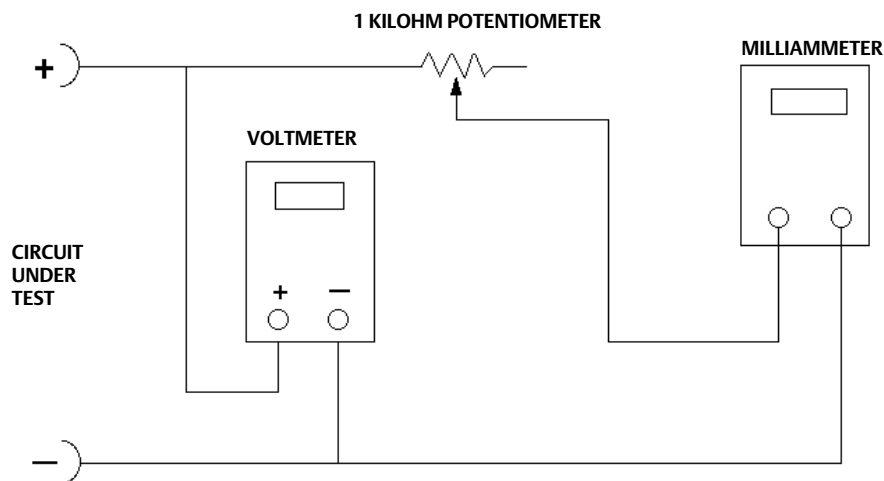

A6192-1

# Technical Support Checklist

Have the following information available prior to contacting your [Emerson sales office](#) or Local Business Partner for support.

1. Instrument serial number as read from nameplate \_\_\_\_\_
2. Is the digital valve controller responding to the control signal? Yes \_\_\_\_\_ No \_\_\_\_\_  
 If not, describe: \_\_\_\_\_
3. Measure the voltage across the “+11” and “-12” terminal box screws when the commanded current is 4.0 mA and 20.0 mA:      V @ 4.0 mA      V @ 20.0 mA.  
 (These values should be around 8.0 V @ 4.0 mA and 8.25 V @ 20 mA.)
4. Is the front panel LCD functional? Yes \_\_\_\_\_ No \_\_\_\_\_
5. Is it possible to communicate with the DVC2000 via the LUI pushbuttons? Yes \_\_\_\_\_ No \_\_\_\_\_
6. Are Travel, Input Signal, and Output Pressure in the LCD shown correctly? Yes \_\_\_\_\_ No \_\_\_\_\_
7. Is it possible to communicate via HART to the DVC2000? Yes \_\_\_\_\_ No \_\_\_\_\_
8. What is the Diagnostic Tier of the digital valve controller? AC \_\_\_\_ HC \_\_\_\_ AD \_\_\_\_ PD \_\_\_\_
9. What is the firmware version of the DVC2000? \_\_\_\_\_
10. What is the hardware version of the DVC2000? \_\_\_\_\_
11. Is the digital valve controller's Instrument Mode “In Service”? Yes \_\_\_\_\_ No \_\_\_\_\_
12. Is the digital valve controller's Control Mode set to “Analog”? Yes \_\_\_\_\_ No \_\_\_\_\_
13. What are the following parameter readings?  
 Input Signal \_\_\_\_\_ Drive Signal \_\_\_\_\_% Pressure \_\_\_\_\_  
 Travel Target \_\_\_\_\_ Travel \_\_\_\_\_%
14. What are the following alert readings?  
 Fail alerts \_\_\_\_\_  
 Valve alerts \_\_\_\_\_  
 Operational status \_\_\_\_\_  
 Alert event record entries \_\_\_\_\_
15. Export ValveLink data (if available) for the device (Status Monitor, Detailed Setup, etc.).

## Mounting

1. Actuator application: Sliding Stem? \_\_\_\_\_ Rotary? \_\_\_\_\_
2. What Make, Brand, Style, Size, etc. actuator is the DVC2000 mounted on? \_\_\_\_\_
3. What is the Mounting Kit part number? \_\_\_\_\_
4. If mounting kits are made by LBP/Customer, please provide pictures of installation.
5. If sliding stem:  
What is the full travel of the valve? \_\_\_\_\_  
Which Magnet Array? 25 mm (1 inch) \_\_\_\_\_ 50 mm (2 inch) \_\_\_\_\_ 110 mm (4-1/8 inch) \_\_\_\_\_  
Does the Magnet Array move through marked areas? Yes \_\_\_\_\_ No \_\_\_\_\_
6. If Rotary: Is the actuator rotation  $\leq 90^\circ$ ? Yes \_\_\_\_\_ No \_\_\_\_\_



## Section 5 Parts

### Parts Ordering

Whenever corresponding with your [Emerson sales office](#) or Local Business Partner about this equipment, always mention the controller serial number. When ordering parts kits, refer to the 11-character part number of each required kit as found in the following list.

#### **⚠ WARNING**

**Use only genuine Fisher replacement parts. Components that are not supplied by Emerson Automation Solutions should not, under any circumstances, be used in any Fisher instrument. Use of components not supplied by Emerson Automation Solutions may void your warranty, might adversely affect the performance of the valve, and could cause personal injury and property damage.**

The DVC2000 digital valve controller is designed with all metric fasteners and threaded connections. However, optional inch connections are available for the two conduit entrance points (1/2 NPT) and the supply/output pneumatic ports (1/4 NPT). Even with this option, all other fasteners and threaded connections are metric.

### Parts Kits

Description	Part Number	Description	Part Number
I/P Converter Kit		Feedback Array Kit	
For GX Actuator	38B6041X182	Sliding Stem (Linear)	
For non-GX Rotary and Sliding-Stem	38B6041X122	[kit contains feedback array and hex socket cap screws, qty. 2, washer, plain, qty. 2, external tooth lock washer, qty. 2 (only with aluminum feedback array kit) and alignment template.	
Low Pressure Relay Kit (white label)		• 210 mm (8-1/4 inch) kit contains feedback array and hex socket cap screws, qty. 4, washer, plain, qty. 4, external tooth lock washer, qty. 4 (only with aluminum feedback array kit), alignment template and insert]. Stainless steel kits only for use with stainless steel mounting kits.	
Housing A (for GX Actuator) (0 - 49 psig)	GE59274X012	7 mm (1/4-inch)	GG20240X012
Housing B (for non-GX Rotary and Sliding-Stem) (0 - 3.3 bar/0 - 49 psig)	GE08910X012	Aluminum	
High Pressure Relay Kit (green label)		19 mm (3/4-inch)	GG20240X022
Housing A (for GX Actuator) (50 - 100 psig)	GE59275X012	Aluminum	
Housing B (for non-GX Rotary and Sliding-Stem) (3.4 - 7.0 bar/50 - 100 psig)	GE08911X012	Stainless steel	GE65853X012
Mounting Frame Kit	GE08912X012	25 mm (1-inch)	
Main Cover Assembly (see figure 5-1, key 13)	GE12427X012	Aluminum	GG20240X032
EMI Shield Kit	GE08913X012	Stainless steel	GE65853X022
		38 mm (1-1/2 inch)	
		Aluminum	GG20240X042
		Stainless steel	GE65853X032
		50 mm (2-inch)	
		Aluminum	GG20240X052
		Stainless steel	GE65853X042
		110 mm (4-1/8 inch)	
		Aluminum	GG20240X082
		Stainless steel	GE65853X062
		210 mm (8-1/4 inch)	
		Aluminum	GG20243X012
		Stainless steel	GE65853X072

Description	Part Number
Feedback Array Kit (cont'd)	
Rotary [Kit contains feedback assembly, pointer assembly, travel indicator scale and M3 machine pan head screws qty. 2]. Stainless steel kits only for use with stainless steel mounting kits.	
Aluminum	GE71982X012
Stainless steel	GE71982X022
Elastomer Kit - includes all accessible elastomers for one complete DVC2000 unit	GE08917X012
Small Hardware Kit -includes all fasteners and plugs (except mounting hardware) for one complete DVC2000 unit	GE08918X012
High Temperature Gasket Set Includes O-ring seal (qty 1) and insulation gaskets (qty 2)	GE26550X012
Replacement housing	
Plastic Vent Construction	
Housing A (for GX Actuator)	
G 1/4 & M20 Metric threaded ports	GE24013X012
1/4 NPT & 1/2 NPT Imperial threaded ports	GE24011X012
Housing B (for non-GX Rotary and Sliding-Stem)	
G 1/4 & M20 Metric threaded ports	GE24012X012
1/4 NPT & 1/2 NPT Imperial threaded ports	GE24010X012
Metal Vent Construction	
Housing A (for GX Actuator)	
G 1/4 & M20 Metric threaded ports	GE74138X012
1/4 NPT & 1/2 NPT Imperial threaded ports	GE74137X012
Housing B (for non-GX Rotary and Sliding-Stem)	
G 1/4 & M20 Metric threaded ports	GE74140X012
1/4 NPT & 1/2 NPT Imperial threaded ports	GE74139X012
Metal Vent Assembly	GE20435X012

## Parts List (refer to figures 5-1, 5-2 and 5-3)

### Note

The parts contained in the Parts List are not available as individual components. All parts are included in the Parts Kits.

## I/P Converter Assembly<sup>(1)</sup>

25	Fasteners
26	O-Ring
41	I/P Converter
231	Screen O-Ring

## Relay Assembly<sup>(2)</sup>

2	Relay
45	O-Rings

## Mounting Frame Assembly<sup>(3)</sup>

3	Mounting Frame
16	Pressure Sensor Seal
19	Fasteners
45	O-Ring
51	O-Ring

## EMI Shield Assembly<sup>(4)</sup>

11	Fasteners (3 req'd)
29	Conductive Gasket (Shield)
37	Primary Shield

1. All parts included in the I/P Converter Kit  
 2. All parts included in the Low Pressure or High Pressure Relay Kits  
 3. All parts included in the Mounting Frame Kit  
 4. All parts included in the EMI Shield Kit

Figure 5-1. FIELDVUE DVC2000 Digital Valve Controller Assembly, Housing A

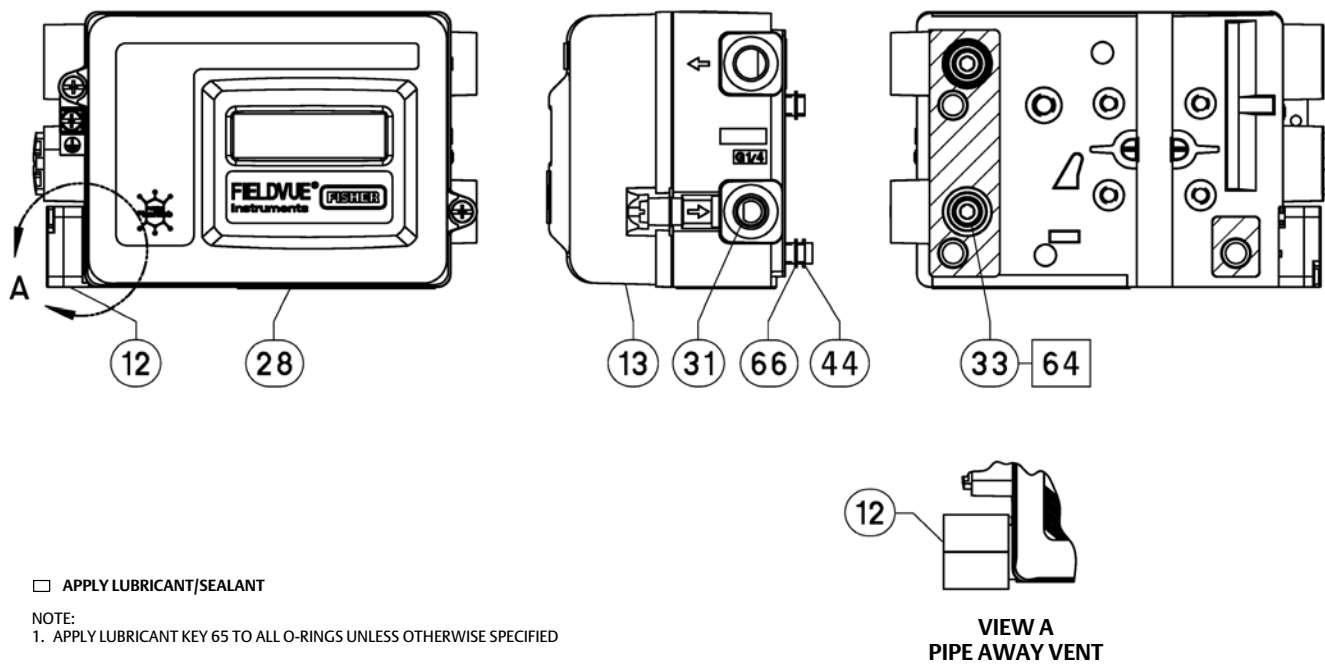
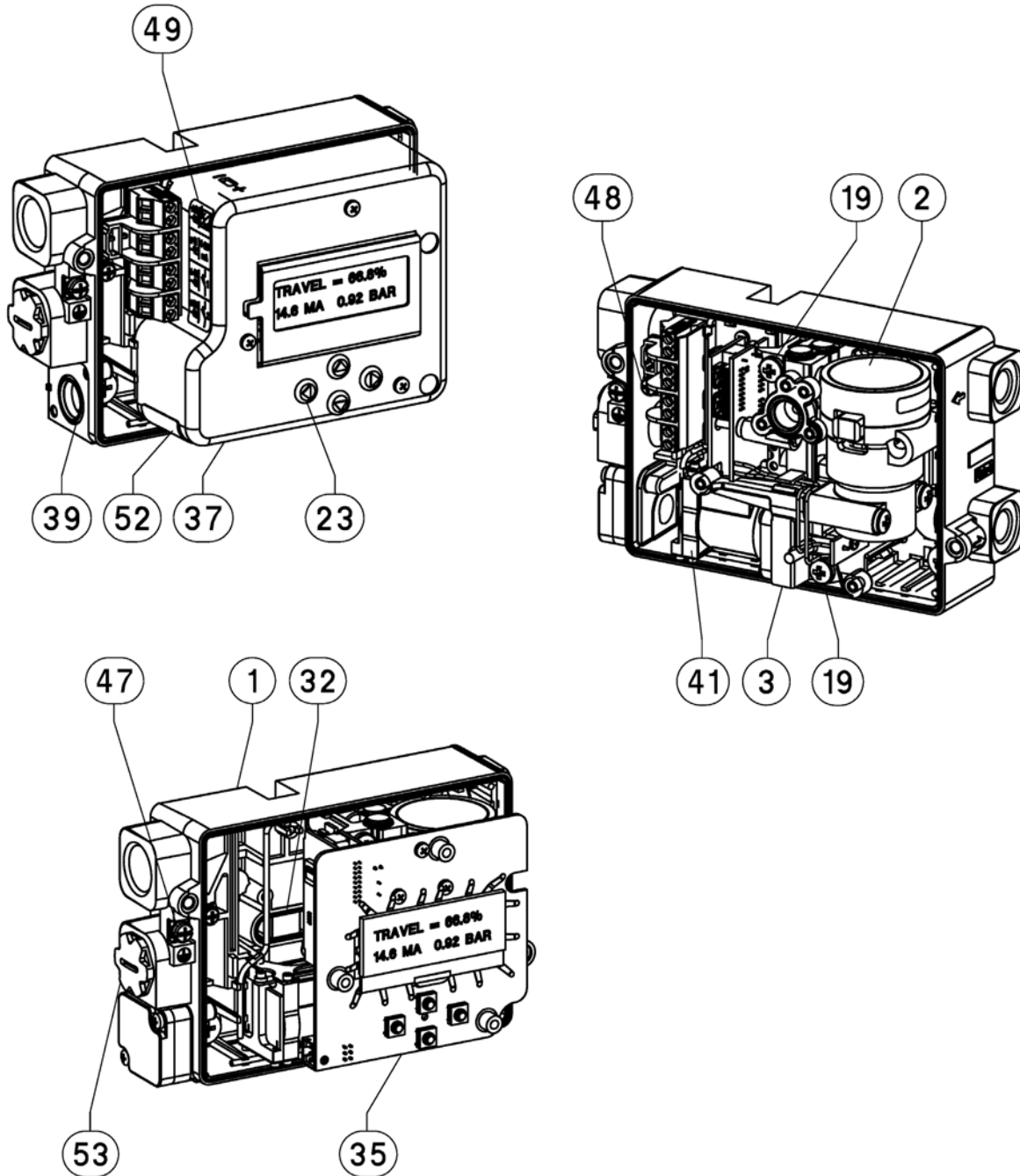

Figure 5-2. FIELDVUE DVC2000 Digital Valve Controller Assembly, Housing A



□ APPLY LUBRICANT/SEALANT

NOTE:

1. APPLY LUBRICANT KEY 65 TO ALL O-RINGS UNLESS OTHERWISE SPECIFIED

GE13174-F, SHEET 2 OF 3

Figure 5-3. FIELDVUE DVC2000 Digital Valve Controller Assembly, Housing A

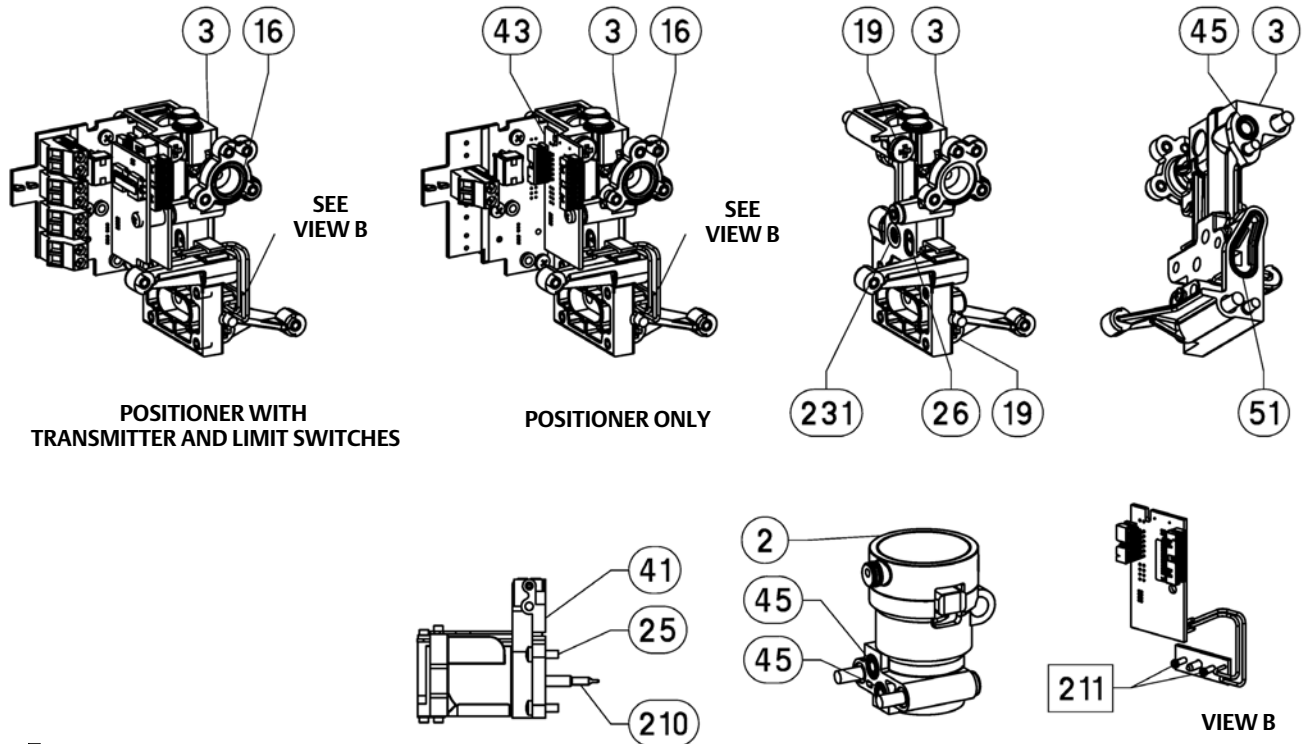

□ APPLY LUBRICANT/SEALANT

NOTE:

1. APPLY LUBRICANT KEY 65 TO ALL O-RINGS UNLESS OTHERWISE SPECIFIED

GE13174-F, SHEET 3 OF 3



# Appendix A Principle of Operation

## DVC2000 Operation

The DVC2000 digital valve controller uses a traditional 4-20 mA input signal and converts it into a pneumatic output pressure that is delivered to the control valve actuator. Accurate control of the position of the valve is enabled by valve stem position feedback. The way in which the DVC2000 accomplishes this is through a two-stage positioner design. Refer to figure A-1 for a block diagram of the positioner operation.

Figure A-1. FIELDVUE DVC2000 Digital Valve Controller Block Diagram

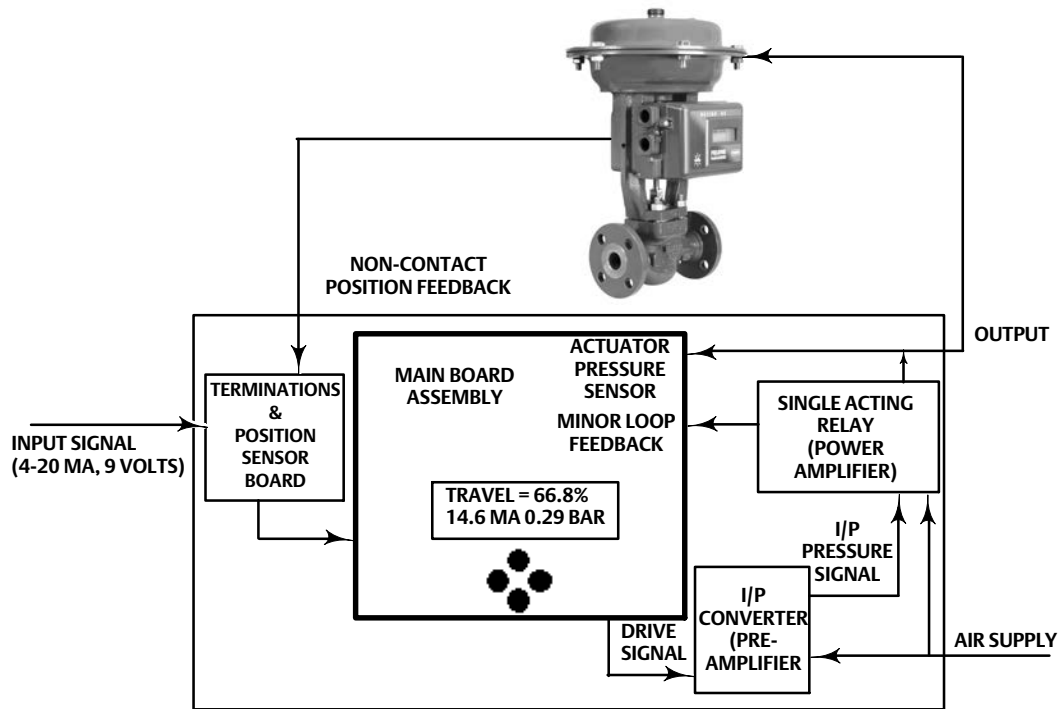

A traditional 4-20 mA signal provides the set point and power to the instrument. At the same time, the HART protocol provides instrument and process data through digital communications. The instrument receives this set point and positions the valve where it needs to be.

- The input signal provides electrical power and the set point simultaneously. It is routed into the terminal board through a twisted pair of wires. The terminal board contains the termination points for the loop signal (+11/-12). If the options board is installed, an additional options board set includes additional terminals for the transmitter output (+31/-32), switch #1 output (+41/-42), and switch #2 output (+51/-52).
- The input signal is then directed to the main electronics board assembly where the microprocessor runs a digital control algorithm resulting in a drive signal to the I/P converter.

- The I/P converter assembly is connected to supply pressure and converts the drive signal into a **pressure signal**. The I/P converter is the pre-amplifier stage in the two-stage positioner design. This component enables high static gain for responsiveness to small changes in the input signal.
- The I/P output is sent to the pneumatic relay assembly. The relay is also connected to supply pressure and amplifies the small pressure signal from the I/P converter into a larger **pneumatic output signal** used by the actuator. The pneumatic relay is the power amplifier stage in the two-stage positioner design. This component enables superior dynamic performance with minimal steady-state air consumption.
- A sensor on the printed wiring board measures the motion of the small valve inside the pneumatic relay. This measurement is used for minor loop feedback to the control algorithm resulting in stable, robust tuning.
- The change in relay output pressure to the actuator causes the valve to move.
- Valve position is sensed through the non-contact, linkage-less feedback sensor. There are no moving linkages and the DVC2000 is physically separated from the valve stem through the use of a magnetic Hall effect sensor. A magnetic array is mounted to the valve stem and the sensor is embedded in the DVC2000 housing. The sensor is electrically connected to the printed wiring board to provide a travel feedback signal used in the control algorithm.

The valve continues to move until the correct position is attained.



## Appendix B Local Interface Flow Chart and Field Communicator Menu Trees

This section contains the Local Interface Flow Chart and the Field Communicator menu trees for instrument level HC, AD, and PD and instrument level AC. It also contains Fast Key Sequence tables with coordinates to help locate the function/variable on the appropriate menu tree.

# Local Interface Flow Chart

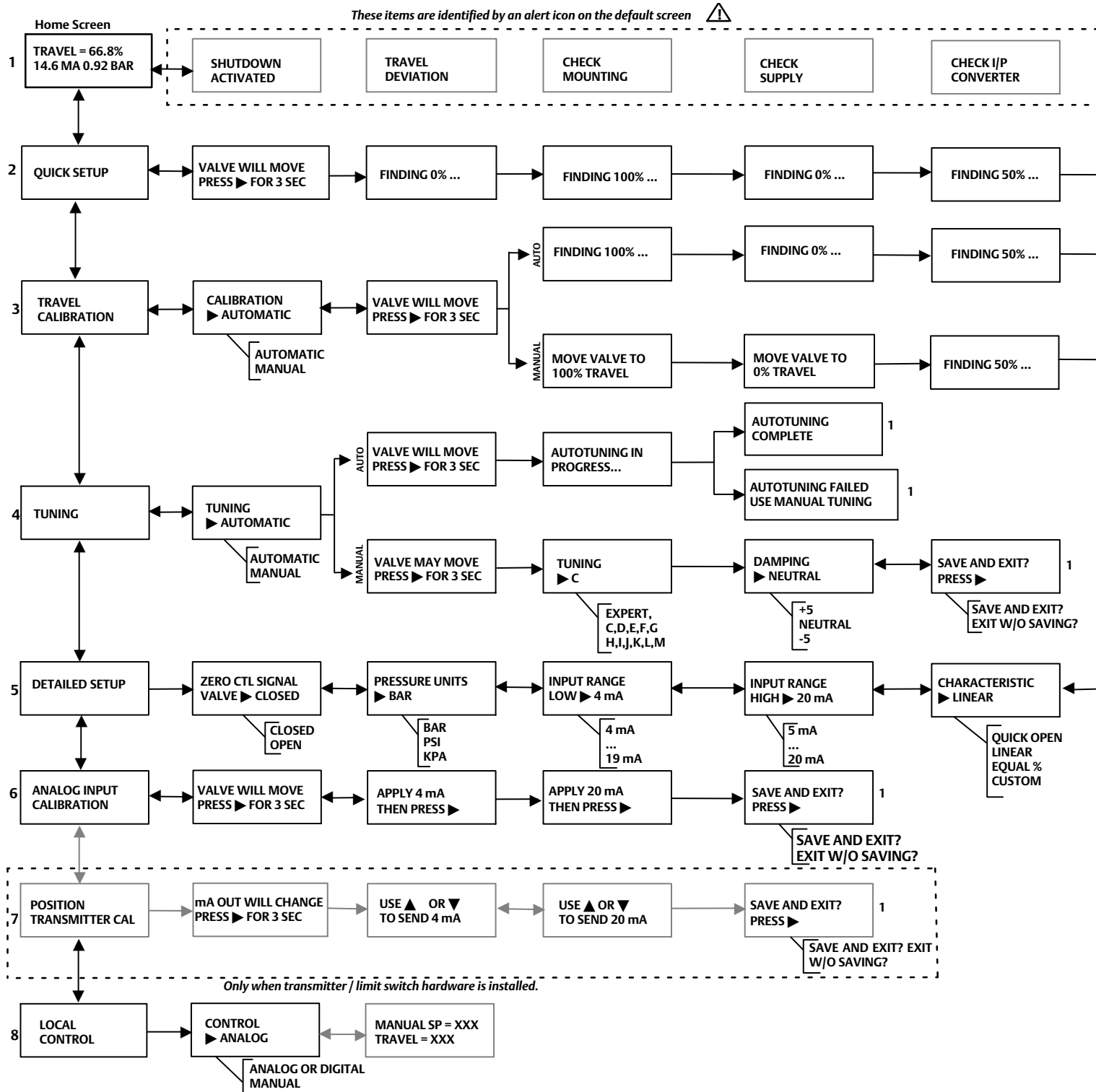



## Field Communicator Fast-Key Sequence (Instrument Level HC, AD and PD)

Function/Variable	Fast-Key Sequence	Coordinates <sup>(1)</sup>
Actuator Style	1-2-5-2	4-E
Alert Record	1-2-7-6	4-G
Analog Input	2	1-E
Analog Input Calibration	1-4-1	2-E
Analog Input Range High	1-2-4-2	4-D
Analog Input Range Low	1-2-4-3	4-D
Analog Input Units	1-2-4-1	4-D
Auto Calibrate Travel	1-4-2	2-E
Auto Setup	1-1-1	2-B
Auto Tuner	1-1-1-3	3-B
Basic Setup	1-1	2-B
Burst	1-2-1-5	4-C
Calibrate	1-4	2-E
Control Mode	1-2-1-2	3-C
Custom Characteristic Table	1-2-6-5	4-F
Cycle Count	1-2-7-4-4	6-H
Cycle Count Alert	1-2-7-4	6-H
Cycle Count Alert Enable	1-2-7-4-1	6-H
Cycle Count Alert Point	1-2-7-4-2	6-H
Cycle Count Deadband	1-2-7-4-3	6-H
Damping Factor	1-1-2-3-2	4-C
Date	1-2-3-4	5-D
Descriptor	1-2-3-3	5-D
Device Description Revision	1-3-3	2-F
Device Identification	1-3-2-9	2-H
Device Information	1-3-2	2-G
Device Revision	1-3-2-2	2-G
Drive Alert Enable	1-2-7-5-1	5-H
Drive Current Fail	1-2-8-4	3-F
Drive Signal	5	1-E
Enable Integral Control	1-2-6-9-1	6-G
Expert Tuning Gains	1-1-1-4-3	5-B
Failure Alerts	7-2	1-G
Failure Group Enable	1-2-7-6-4-2	6-I
Firmware Date	1-3-2-4	2-G
Firmware Revision	1-3-2-3	2-G
Flash Rom Failure	1-2-8-1	3-E
HART Tag	1-2-3-1	5-D
HART Universal Revision	1-3-2-1	2-G
Input Characterization	1-2-6-4	4-F
Instrument Level	1-3-2-8	2-G
Instrument Mode	Hot Key	1-A
Instrument Serial Number	1-2-3-6	5-D
Instrument Status	7	1-E
Integral Dead Zone	1-2-6-9-3	6-G
Integral Gain	1-2-6-9-2	6-G
Integral Settings	1-2-6-9	6-G
Limit Switch Stat Enable	1-2-7-6-4-3	6-I
LUI Language	1-2-3-8	5-D
LUI Pressure Units	1-2-4-5	4-D
Main Electronics Revision	1-3-2-5	2-G
Manual Calibrate Travel	1-4-3	2-E
Manual Setup	1-1-2	3-B
Maximum Supply Pressure	1-2-5-1	4-E
Message	1-2-3-2	5-D
Minimum Opening Time	1-2-6-8-1	6-F
Minimum Closing Time	1-2-6-8-2	6-F
NVM Fail	1-2-8-5	3-F
Operational Status	7-3	1-G

Function/Variable	Fast-Key Sequence	Coordinates <sup>(1)</sup>
Polling Address	1-2-3-7	5-D
Pressure	6	1-E
Pressure Calibration	1-4-4	2-E
Pressure Sensor Failure	1-2-8-7	3-F
Pressure Units	1-2-4-4	4-D
Protection	Hot Key	1-A
Reference Voltage Failure	1-2-8-3	3-F
Response Control	1-2-6	4-E
Restart	1-2-1-4	3-C
Restart Control Mode	1-2-1-3	3-C
Secondary Electronics Revision	1-3-2-6	2-G
Self Test Shutdown	1-2-8	2-D
Sensor Serial Number	1-3-2-7	2-G
Set Point Filter Time	1-2-6-6	4-F
Setup Wizard	1-1-1-1	3-B
Stroke Valve	1-5	1-D
Switch 1 Closed <sup>(2)</sup>	1-2-9-2	3-E
Switch 1 Trip Point <sup>(2)</sup>	1-2-9-1	3-D
Switch 2 Closed <sup>(2)</sup>	1-2-9-4	3-E
Switch 2 Trip Point <sup>(2)</sup>	1-2-9-3	3-E
Temperature	1-3-1-1	3-G
Temperature Comp Fail	1-2-8-2	3-F
Temperature Sensor Fail	1-2-8-6	3-F
Temperature Units	1-2-4-6	4-D
Transmitter Action <sup>(2)</sup>	1-2-9-5	3-E
Transmitter Calibration <sup>(2)</sup>	1-4-6	2-E
Travel	3	1-E
Travel Accumulator	1-2-7-3-4	5-H
Travel Accumulator Alert Enable	1-2-7-3-1	5-G
Travel Accumulator Alert Point	1-2-7-3-2	5-G
Travel Accumulator Dead Band	1-2-7-3-3	5-G
Travel Alert Deadband	1-2-7-1-7	5-G
Travel Alert High Point	1-2-7-1-3	5-G
Travel Alert High High Point	1-2-7-1-5	5-G
Travel Alert Low Point	1-2-7-1-4	5-G
Travel Alert Low Low Point	1-2-7-1-6	5-G
Travel Cutoff Low	1-2-6-7-4	6-F
Travel Cutoff High	1-2-6-7-3	6-F
Travel Deviation Alert Enable	1-2-7-2-1	6-G
Travel Deviation Alert Point	1-2-7-2-2	6-G
Travel Deviation Time	1-2-7-2-3	6-G
Travel High / Low Enable	1-2-7-1-1	5-F
Travel High High / Low Low Enable	1-2-7-1-2	5-F
Travel Limit High	1-2-6-7-1	6-E
Travel Limit Low	1-2-6-7-2	6-F
Travel Sensor Failure	1-2-8-8	3-F
Travel Setpoint	4	1-E
Tuning	Hot Key	1-B
Tuning Set	1-1-2-3-1	4-C
Valve Group Enable	1-2-7-6-4-1	6-I
Valve Style	1-2-5-3	4-E
Valve Serial Number	1-2-3-5	5-D
Zero Control Signal	1-2-5-4	4-E

- Coordinates are to help locate the item on the menu tree on the facing page.
- Available only if the instrument has a transmitter and limit switches installed.

# Field Communicator Menu Tree for Instrument Level HC, AD and PD



Hot Key

- 1 Instrument Mode
- 2 Protection
- 3 Tuning

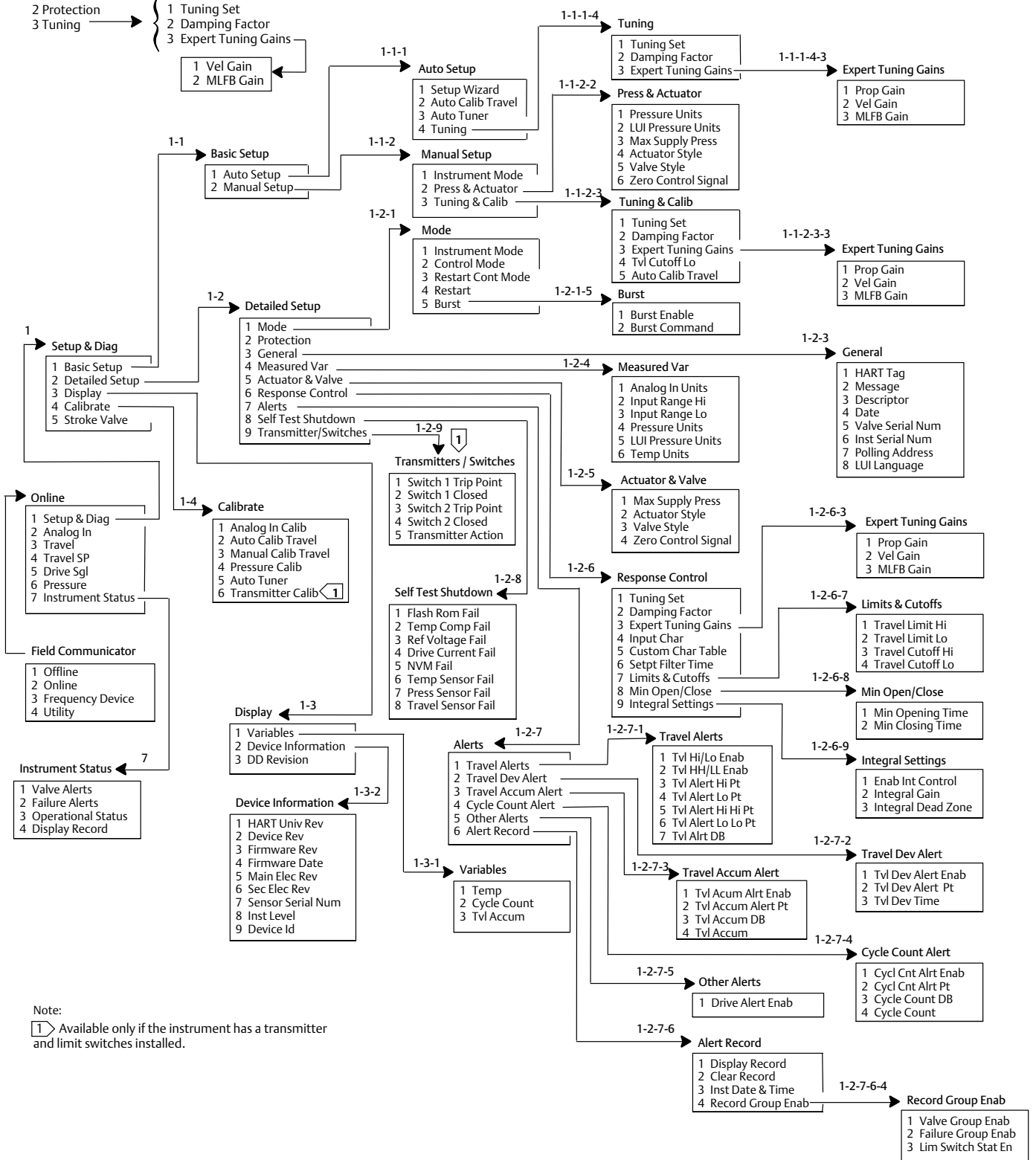

Note:  
 [1] Available only if the instrument has a transmitter and limit switches installed.

A  
—  
B  
—  
C  
—  
D  
—  
E  
—  
F  
—  
G  
—  
H  
—  
I

## Field Communicator Fast-Key Sequence (Instrument Level AC)

Function/Variable	Fast-Key Sequence	Coordinates <sup>(1)</sup>
Analog Input Calibration	1-3-1	3-E
Analog Input Units	1-2-2-1	4-E
Auto Calibrate Travel	1-3-2	3-E
Auto Setup	1-1-1	3-B
Auto Tuner	1-1-1-3	3-B
Basic Setup	1-1	3-B
Calibrate	1-3	3-E
Damping Factor	1-1-1-4-2	5-B
Date	1-2-1-4	4-D
Descriptor	1-2-1-3	4-D
Detailed Setup	1-2	3-D
Device Description Revision	2-2	2-F
Device Identification	2-1-9	3-F
Device Information	2-1	3-F
Device Revision	2-1-2	3-F
Display	2	1-E
Enable Integral Control	1-2-3-6-1	6-F
Expert Tuning Gains	1-1-1-4-3	6-C
Firmware Date	2-1-4	3-F
Firmware Revision	2-1-3	3-F
HART Tag	1-2-1-1	4-D
HART Universal Revision	2-1-1	3-F
Input Characterization	1-2-3-4	4-F
Input Range High	1-2-2-2	4-E
Input Range Low	1-2-2-3	4-E
Instrument Level	2-1-8	3-F
Instrument Mode	Hot Key	1-A
Instrument Serial Number	1-2-1-6	4-E
Integral Dead Zone	1-2-3-6-3	6-F

Function/Variable	Fast-Key Sequence	Coordinates <sup>(1)</sup>
Integral Gain	1-2-3-6-2	6-F
Integral Settings	1-2-3-6	6-F
LUI Language	1-2-1-8	4-E
LUI Pressure Units	1-2-2-5	4-E
Manual Calibrate Travel	1-3-3	3-E
Manual Setup	1-1-2	3-B
Measured Variable	1-2-2	4-E
Main Electronics Revision	2-1-5	3-F
Maximum Supply Pressure	1-1-2-2-3	5-C
Message	1-2-1-2	4-D
Polling Address	1-2-1-7	4-E
Pressure Units	1-2-2-4	4-E
Protection	Hot Key	1-A
Secondary Electronics Revision	2-1-6	3-F
Sensor Serial Number	2-1-7	3-F
Setup Wizard	1-1-1-1	3-B
Switch 1 Closed <sup>(2)</sup>	1-2-4-2	4-G
Switch 1 Trip Point <sup>(2)</sup>	1-2-4-1	4-G
Switch 2 Closed <sup>(2)</sup>	1-2-4-4	4-G
Switch 2 Trip Point <sup>(2)</sup>	1-2-4-3	4-G
Transmitter Action <sup>(2)</sup>	1-2-4-5	4-G
Transmitter Calibration <sup>(2)</sup>	1-3-4	3-E
Travel Cutoff High	1-2-3-5-1	6-F
Travel Cutoff Low	1-2-3-5-2	6-F
Tuning	Hot Key	1-B
Tuning Set	1-1-1-4-1	5-B
Valve Serial Number	1-2-1-5	4-E
Zero Control Signal	1-1-2-2-4	5-C

1. Coordinates are to help locate the item on the menu tree on the facing page.

2. Available only if the instrument has a transmitter and limit switches installed.

# Field Communicator Menu Tree for Instrument Level AC



Hot Key

- 1 Instrument Mode
- 2 Protection
- 3 Tuning

- 1 Tuning Set
- 2 Damping Factor
- 3 Expert Tuning Gains

- 1 Prop Gain
- 2 Vel Gain
- 3 MLFB Gain

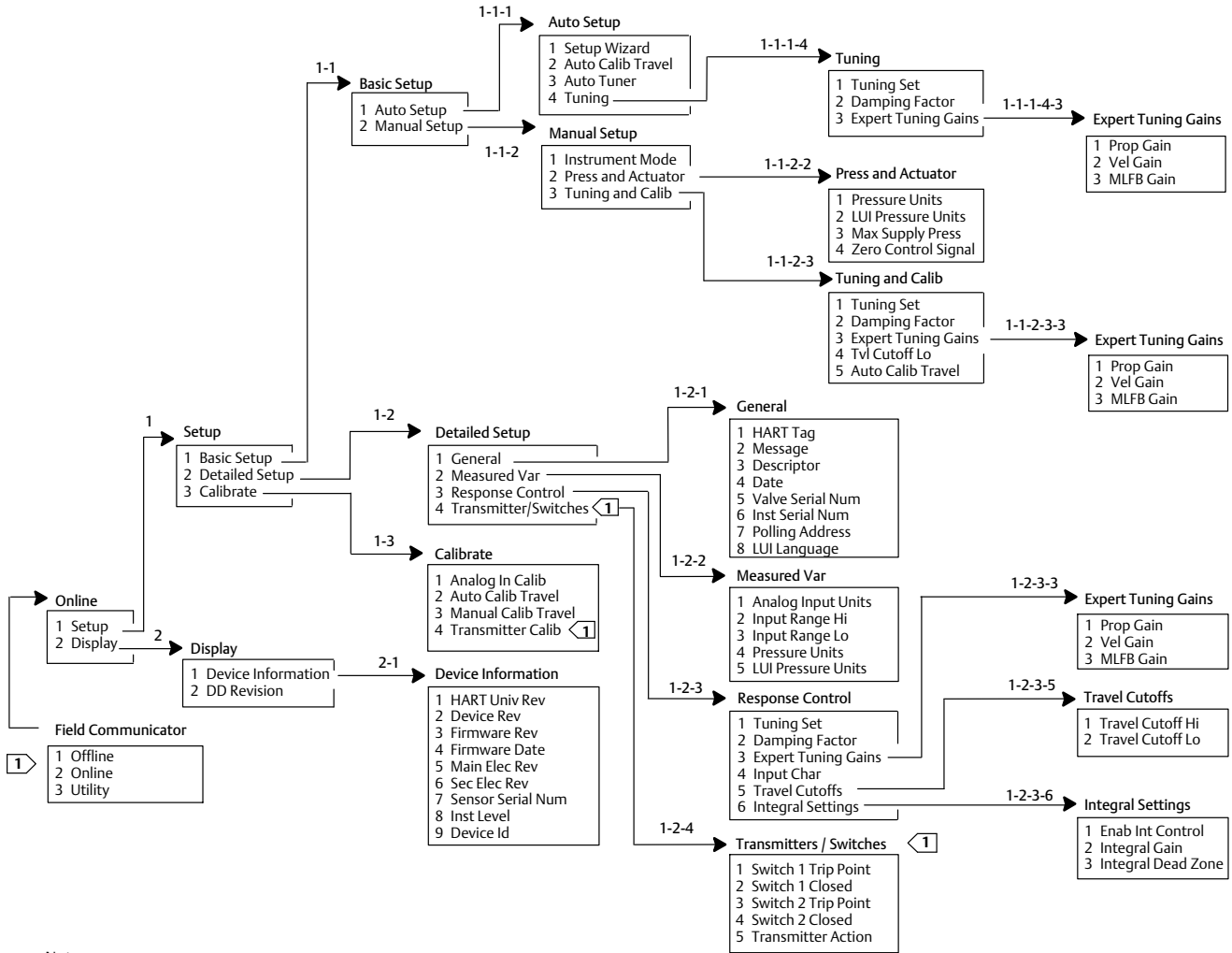

Note:

1 Available only if the instrument has a transmitter and limit switches installed.

A

B

C

D

E

F

G

H

I





# Glossary

## Alert Point

An adjustable value that, when exceeded, activates an alert.

## Algorithm

A set of logical steps to solve a problem or accomplish a task. A computer program contains one or more algorithms.

## Alphanumeric

Consisting of letters and numbers.

## Analog Input Units

Units in which the analog input is displayed and maintained in the instrument.

## ANSI (acronym)

The acronym ANSI stands for the American National Standards Institute

## ANSI Class

Valve pressure/temperature rating.

## Bench Set

Pressure, supplied to an actuator, required to drive the actuator through rated valve travel. Expressed in pounds per square inch.

## Byte

A unit of binary digits (bits). A byte consists of eight bits.

## Calibration Location

Where the instrument was last calibrated; either in the factory or in the field.

## Configuration

Stored instructions and operating parameters for a FIELDVUE Instrument.

## Control Loop

An arrangement of physical and electronic components for process control. The electronic components of the loop continuously measure one or more aspects of the process, then alter those aspects as necessary to achieve a desired process condition. A simple control loop measures only one variable. More sophisticated control loops measure many variables and maintain specified relationships among those variables.

## Control Mode

Defines where the instrument reads its set point. The following control modes are available for a FIELDVUE instrument:

**Analog** The instrument receives its travel set point over the 4-20 mA loop.

**Digital** The instrument receives its set point digitally, via the HART communications link.

**Test** This is not a user-selectable mode. The Field Communicator or ValveLink Software places the instrument in this mode whenever it needs to move the valve, such as for calibration or diagnostic tests.

## Control Mode, Restart

Determines the instrument control mode after a restart. See Control Mode for the available restart control modes.

**Controller**

A device that operates automatically to regulate a controlled variable.

**Current-to-Pressure (I/P) Converter**

An electronic component or device that converts a milliamp signal to a proportional pneumatic pressure output signal.

**Cycle Counter**

The capability of a FIELDVUE instrument to record the number of times the travel changes direction. The change in direction must occur after the deadband has been exceeded before it can be counted as a cycle.

**Cycle Counter Alert**

Checks the difference between the Cycle Counter and the Cycle Counter Alert Point. Cycle Counter Alert is active when the cycle counter value exceeds the Cycle Counter Alert Point. It clears after you reset the Cycle Counter to a value less than the alert point.

**Cycle Counter Alert Point**

An adjustable value which, when exceeded, activates the Cycle Counter Alert. Valid entries are 0 to 4 billion cycles.

**Cycle Counter Deadband**

Region around the travel reference point, in percent of ranged travel, established at the last increment of the Cycle Counter. The deadband must be exceeded before a change in travel can be counted as a cycle. Valid entries are 0% to 100%. Typical value is between 2% and 5%.

**Deviation**

Usually, the difference between set point and process variable. More generally, any departure from a desired or expected value or pattern.

**Device ID**

Unique identifier embedded in the instrument at the factory.

**Device Revision**

Revision number of the interface software that permits communication between the Field Communicator and the instrument.

**Drive Signal**

The signal to the I/P converter from the printed wiring board. It is the percentage of the total microprocessor effort needed to drive the valve fully open.

**Drive Signal Alert**

Checks the drive signal and calibrated travel. If one of the following conditions exists for more than 20 seconds, the Drive Signal Alert is active. If none of the conditions exist, the alert is cleared.  
**If Zero Control Signal = Closed**

The alert is active when:

drive signal <10% and calibrated travel >3%

drive signal >90% and calibrated travel <97%

**If Zero Control Signal = Open**

The alert is active when:

drive signal <10% and calibrated travel <97%

drive signal >90% and calibrated travel >3%

**Equal Percentage**

A valve flow characteristic where equal increments of valve stem travel produce equal percentage changes in existing flow. One of the input characteristics available for a FIELDVUE Instrument. See also, Linear and Quick Opening.

**Feedback Signal**

Indicates to the instrument the actual position of the valve. The travel sensor provides the feedback signal to the instrument printed wiring board assembly.

**Firmware Revision**

The revision number of the instrument firmware. Firmware is a program that is entered into the instrument at time of manufacture and cannot be changed by the user.

**Free Time**

Percent of time that the microprocessor is idle. A typical value is 25%. The actual value depends on the number of functions in the instrument that are enabled and on the amount of communication currently in progress.

**Full Ranged Travel**

Current, in mA, that corresponds with the point where ranged travel is maximum, i.e., limited by the mechanical travel stops.

**Gain**

The ratio of output change to input change.

**Hardware Revision**

Revision number of the Fisher instrument hardware. The physical components of the instrument are defined as the hardware.

**HART (acronym)**

The acronym HART stands for Highway Addressable Remote Transducer.

**HART Tag**

An eight-character name that identifies the physical instrument.

**HART Universal Revision**

Revision number of the HART Universal Commands which are the communications protocol for the instrument.

**Input Characteristic**

The relationship between the ranged travel and ranged input. Possible values include: linear, equal percentage, and quick opening.

**Input Current**

The current signal from the control system that serves as the analog input to the instrument. See also Input Signal.

**Input Range**

The analog input signal range that corresponds to the travel range.

**Input Signal**

The current signal from the control system. The input signal can be displayed in milliamperes or in percent of ranged input.

**Instrument Level**

Determines the functions available for the instrument. See table 3-1.

**Instrument Mode**

Determines if the instrument responds to its analog input signal. There are two instrument modes:

**In Service:** For a fully functioning instrument, the instrument output changes in response to analog input changes. Typically changes to setup or calibration cannot be made when the instrument mode is In Service.

**Out of Service:** The instrument output does not change in response to analog input changes when the instrument mode is Out of Service. Some setup parameters can be changed only when the instrument mode is Out of Service.

## Instrument Protection

Determines if commands from a HART device can calibrate and/or configure certain parameters in the instrument. There are two types of instrument protection:

**Configuration and Calibration:** Prohibits changing protected setup parameters; prohibits calibration.

**None:** Permits both configuration and calibration. The instrument is "unprotected."

## Instrument Serial Number

The serial number assigned to the printed wiring board by the factory but can be changed during setup. The instrument serial number should match the serial number on the instrument nameplate.

## Leak Class

Defines the allowable leakage by a valve when it is closed. Leak class numbers are listed in two standards: ANSI/FCI 70-2-1991 and IEC 534-4.

## Linear

A valve flow characteristic where changes in flow rate are directly proportional to changes in valve stem travel. One of the input characteristics available for a FIELDVUE Instrument. See also, Equal Percentage and Quick Opening.

## Linearity, dynamic

Linearity (independent) is the maximum deviation from a straight line best fit to the opening and closing curves and a line representing the average value of those curves.

## Memory

A type of semiconductor used for storing programs or data. FIELDVUE instruments use three types of memory: Random Access Memory (RAM), Read Only Memory (ROM), and Non-Volatile Memory (NVM). See also these listings in this glossary.

## Menu

A list of programs, commands, or other activities that you select by using the arrow keys to highlight the item then pressing ENTER, or by entering the numeric value of the menu item.

## Minimum Closing Time

Minimum time, in seconds, for the travel to decrease through the entire ranged travel. This rate is applied to any travel decrease. Valid entries are 0 to 400 seconds. Deactivate by entering a value of 0 seconds.

## Minimum Opening Time

Minimum time, in seconds, for the travel to increase through the entire ranged travel. This rate is applied to any travel increase. Because of friction, actual valve travel may not respond in exactly the same time frame. Valid entries are 0 to 400 seconds. Deactivate by entering a value of 0 seconds.

## Non-Volatile Memory (NVM)

A type of semiconductor memory that retains its contents even though power is disconnected. NVM contents can be changed during configuration unlike ROM which can be changed only at time of instrument manufacture. NVM stores configuration restart data.

## Parallel

Simultaneous: said of data transmission on two or more channels at the same time.

## Polling Address

Address of the instrument. If the digital valve controller is used in a point-to-point configuration, set the polling address to 0. If it is used in a multidrop configuration, or split range application, set the polling address to a value from 0 to 15.

## Pressure Sensor

A FIELDVUE instrument internal device that senses pneumatic pressure. DVC2000 digital valve controllers have one actuator pressure sensor.

## Primary Master

Masters are communicating devices. A primary master is a communicating device permanently wired to a field instrument. Typically, a HART-compatible control system or a computer running ValveLink Software is the primary master.

In contrast, a secondary master is not often permanently wired to a field instrument. The 375 Field Communicator or a computer running ValveLink Software communicating through a HART modem could be considered a secondary master.

**Note:** If one type of master takes an instrument Out Of Service, the same type must put it In Service. For example, if a device set up as a primary master takes an instrument Out Of Service, a device set up as a primary master must be used to place the instrument In Service.

## Quick Opening

A valve flow characteristic where most of the change in flow rate takes place for small amounts of stem travel from the closed position. The flow characteristic curve is basically linear through the first 40 percent of stem travel. One of the input characteristics available for a FIELDVUE Instrument. See also, Equal Percentage and Linear.

## Random Access Memory (RAM)

A type of semiconductor memory that is normally used by the microprocessor during normal operation that permits rapid retrieval and storage of programs and data. See also Read Only Memory (ROM) and Non-Volatile Memory (NVM).

## Rate

Amount of change in output proportional to the rate of change in input.

## Read-Only Memory (ROM)

A memory in which information is stored at the time of instrument manufacture. You can examine but not change ROM contents.

## Seat Load

Force exerted on the valve seat, typically expressed in pounds force per lineal inch of port circumference. Seat load is determined by shutoff requirements.

## Set Point Filter Time

The time constant, in seconds, for the first-order input filter.

## Software

Microprocessor or computer programs and routines that reside in alterable memory (usually RAM), as opposed to firmware, which consists of programs and routines that are programmed into memory (usually ROM) when the instrument is manufactured. Software can be manipulated during normal operation, firmware cannot.

## Stroking Time

The time, in seconds, required to move the valve from its fully open position to fully closed, or vice versa.

## Temperature Sensor

A device within the FIELDVUE instrument that measures the instrument's internal temperature.

## Travel

Movement of the valve stem or shaft which changes the amount the valve is open or closed.

## Travel Accumulator

The capability of a FIELDVUE instrument to record total change in travel. The value of the Travel Accumulator increments when the magnitude of the change exceeds the Travel Accumulator Deadband. To reset the Travel Accumulator, set it to zero.

**Travel Accumulator Alert**

Checks the difference between the Travel Accumulator value and the Travel Accumulator Alert Point. The Travel Accumulator Alert is active when the Travel Accumulator value exceeds the Travel Accumulator Alert Point. It clears after you reset the Travel Accumulator to a value less than the alert point.

**Travel Accumulator Alert Point**

An adjustable value which, when exceeded, activates the Travel Accumulator Alert. Valid entries are 0% to 4 billion %.

**Travel Accumulator Deadband**

Region around the travel reference point established at the last increment of the accumulator. This region must be exceeded before a change in travel can be accumulated. Valid entries are 0% to 100%.

**Travel Alert**

Checks the ranged travel against the travel high and low alert points. The travel alert is active if either the high or low point is exceeded. Once a high or low point is exceeded, the ranged travel must clear that point by the Travel Alert Deadband before the alert clears. Four travel alerts are available: Travel Alert Hi, Travel Alert Lo, Travel Alert Hi Hi, and Travel Alert Lo Lo.

**Travel Alert Deadband**

Travel, in percent of ranged travel, required to clear a travel alert, once it is active. Valid entries are -25% to 125%.

**Travel Alert High Point**

Value of the travel, in percent of ranged travel, which, when exceeded, sets the Travel Alert Hi alert. Valid entries are -25% to 125%.

**Travel Alert High High Point**

Value of the travel, in percent of ranged travel, which, when exceeded, sets the Travel Alert Hi Hi alert. Valid entries are -25% to 125%.

**Travel Alert Low Point**

Value of the travel, in percent of ranged travel, which, when exceeded, sets the Travel Alert Lo alert. Valid entries are -25% to 125%.

**Travel Alert Low Low Point**

Value of the travel, in percent of ranged travel, which, when exceeded, sets the Travel Alert Lo Lo alert. Valid entries are -25% to 125%.

**Travel Cutoff**

Defines the cutoff point for the travel, in percent of ranged travel. There are two travel cutoffs: high and low. Once travel exceeds the cutoff, the drive signal is set to either maximum or minimum, depending on the Zero Control Signal and if the cutoff is high or low. Minimum opening time or minimum closing time are not in effect while the travel is beyond the cutoff. Use the travel cutoff to obtain the desired seat load or to be sure the valve is fully open.

**Travel Deviation**

The difference between the analog input signal (in percent of ranged input), the “target” travel, and the actual “ranged” travel.

**Travel Deviation Alert**

Checks the difference between the target and the ranged travel. If the difference exceeds the Travel Deviation Alert Point for more than the Travel Deviation Time, the Travel Deviation Alert is active. It remains active until the difference is less than the Travel Deviation Alert Point.

**Travel Deviation Alert Point**

An adjustable value for the target travel and the ranged travel difference, expressed in percent. When this value is exceeded by the travel deviation for more than the Travel Deviation Time, the Travel Deviation Alert is active. Valid entries are 0% to 100%. Typically this is set to 5%.

**Travel Deviation Time**

The time, in seconds, that the travel deviation must exceed the Travel Deviation Alert Point before the alert is active. Valid entries are 1 to 60 seconds.

**Travel Limit**

A setup parameter that defines the maximum allowable travel (in percent of ranged travel) for the valve. During operation, the travel target will not exceed this limit. There are two travel limits: high and low. Typically the travel limit low will be used to keep the valve from going completely closed.

**Travel Range**

Travel, in percent of calibrated travel, that corresponds to the input range.

**Travel Sensor**

A device within the FIELDVUE instrument that senses valve stem or shaft movement.

**Tuning**

The adjustment of control terms or parameter values to produce a desired control effect.

**Tuning Set**

Preset values that identify gain settings for a FIELDVUE instrument. The tuning set and supply pressure together determine an instrument's response to input signal changes.

**Watch Dog Timer**

A timer that the microprocessor must rearm periodically. If the microprocessor is unable to rearm the timer, the instrument goes through reset.

**Zero Control Signal**

A setup parameter that determines whether the valve is fully open or fully closed when the input signal is 0%.





# Index

## A

- AC (Auto Calibrate), 4, 34
- Actuator and Valve Information, 16
- Actuator Information, for Setup, 12
- AD (Advanced Diagnostics), 4, 34
- Advanced Diagnostics (AD), 4, 34
- Air Capacity, 5
- Air Consumption, 5
- Airset option, 6
- Alert Record, 23, 36
  - Clearing, 23
  - Displaying, 23
  - Enabling Alert Groups, 23
  - Inst Date & Time, 23
- Alert Record has Entries, 35
- Alert Record is full, 35
- Alerts, 19
  - Alert Record, 36
  - Enabling
    - Cycle Counter, 22
    - Drive Signal, 23
    - Travel Accumulator, 21
    - Travel Alerts
      - High and Low, 20
      - High High and Low Low, 20
    - Travel Deviation, 21
  - Setting, 19
    - Cycle Counter, 22
    - Other Alerts, 23
    - Travel Alerts, 20
      - High, High-High, Low and Low-Low, 20
      - Travel Accumulation, 21
      - Travel Deviation, 21
  - Valve Alerts, 35
- Analog Calibration Adjust, 29
- Analog Input
  - Calibration, 27
  - Display Value, 33
  - Range Hi, 15
  - Range Lo, 15
- Analog Input , Calibration
  - using the Field Communicator, 27
  - via Local Interface, 28
- Analog Input Signal, 5

- Analog Input Units, 15
- ATEX, Hazardous Area Classification, 5
- Auto Calibrate (AC), 4, 34
- Auto Calibrate Travel, 28
- auto tuner, 26

## B

- Basic Setup and Calibration, using the Local Operator Interface, 3
- Burst Mode, 10
  - Commands, 10
  - Enabling, 10

## C

- Calibration
  - Analog Input, 27
    - using the Field Communicator, 27
    - via Local Interface, 28
  - Auto Calibrate Travel, 28
  - Manual Calibrate Travel, 29
  - Output Pressure Sensor, 30
  - Position Transmitter, 31
  - Pressure Sensor, 30
- Certifications
  - CUTR, Russia, Kazakhstan, Belarus, and Armenia, 6
  - INMETRO, Brazil, 6
  - KGS, South Korea, 6
  - NEPSI, China, 6
  - PESO CCOE, India, 6
- Clear Record, 23
- Command 3, 10
- Component Replacement, 41
- Config & Calib, 12
- Connections
  - Electrical, 3
  - Pneumatic, 3
  - specifications, 6
- Control Mode, 9
- CSA, Hazardous Area Classification, 5
- Customs Union Technical Regulations (CUTR), Russia, Kazakhstan, Belarus, and Armenia, Certification, 6

## Cycle Counter

- Displaying Value, 33
- Enabling Alert, 22
- Resetting, 23

Cycle Counter Alert, 22, 35

Cycle Counter Alert Enable, 22

Cycle Counter Alert Point, 22

Cycle Counter Deadband, 22

**D**

Damping Factor, Tuning, 17

Date, 14

Declaration of SEP, 6

Descriptor, 14

Detailed Setup, 9

Detailed Setup Parameters, Factory Default, 11

Device ID, 34

Device Information, 34

Device Revision, 34

Digital Calibration Adjust, 29

Display Record, 23

Drive Alert Enable, 23

Drive Current Failure, 24, 36

Drive Signal, 23, 55

- Displaying Value, 33
- Enabling Alert, 23

Drive Signal Alert, 35

**E**

Educational Services, 8

Electrical Classification, 5

- Electrical Housing, 6
- Hazardous Area, 5

Electrical Connections, 3

Electrical Housing Classification, 6

Electromagnetic Compatibility, 5

EMC Summary Results, Immunity, 7

Expert Tuning, Gains, 17

**F**

Factory Default Settings, Detailed Setup Parameters, 11

Failure Alerts, 36

- Drive Current Fail, 36

- Flash ROM Fail, 36

- NVM Fail, 36

- Offline/Failed, 36

- Pressure Sensor Fail, 36

- Ref Voltage Fail, 36

- Temperature Sensor Fail, 36

- Travel Sensor Fail, 36

Fast Key Sequences, Field Communicator, 57

Firmware Date, 34

Firmware Revision, 34

Flash ROM Failure, 24, 36

FM, Hazardous Area Classification, 5

**G**

General Information, 14

**H**

HART Communicating (HC), 4, 34

HART Tag, 14

HART Universal Revision, 34

Hazardous Area Classifications

- ATEX, 5
- CSA, 5
- FM, 5
- IECEX, 5

HC (HART Communicating), 4, 34

**I**

I/P Converter

- Assembly, 43
- Removal, 42
- Replacing, 41

IEC 60534-6-1 mounting standards, 5

IEC 60534-6-2 mounting standards, 5

IEC 61326-1 (First Edition), 5

IECEX, Hazardous Area Classification, 5

Independent Linearity, 5

INMETRO, Brazil, Certification, 6  
 Input Characteristic, 17  
 Input Impedance, 5  
 Input Range High, 15  
 Input Range Low, 15  
 Input Signal, 5, 55  
     Analog Input Signal, 5  
     Maximum Voltage, 5  
     Minimum Control Current, 5  
     Minimum Voltage, 5  
     Overcurrent Protection, 5  
     Reverse Polarity Protection, 5  
 Inst Date & Time, Alert Record, 23  
 Installation, 3  
 Instrument Clock, Setting, 23  
 Instrument Level, 4, 34  
 Instrument Mode, 9  
 Instrument Removal, 40  
 Instrument Replacement, 40  
 Instrument Serial Number, 14  
 Instrument Status, 35  
 Instrument Time is Invalid, 35  
 Integral Dead Zone, 19  
 Integral Enable, 19  
 Integral Gain, 19  
 Internal Temperature Sensor, Self Test Failure, 24  
 ISA Standard 7.0.01, 5  
 ISO 8573-1, 5

## **K**

KGS, South Korea, Certification, 6

## **L**

Limit Switches, 6  
     OFF State, 6  
     ON State, 6  
     Supply Voltage, 6  
 Local Interface, 4  
 Local Interface Flow Chart, 58  
 LUI Language, 14

LUI Pressure Units, 15

## **M**

Magnet Assembly, 4  
 Magnetic Feedback Assembly, Replacing, 41  
 Main Electronics Revision, 34  
 Manual Calibrate Travel, 29  
 Materials of Construction, DVC2000, 6  
 Maximum Supply Pressure, 16  
 Maximum Voltage, 5  
 Message, 14  
 Minimum Closing Time, 19  
 Minimum Control Current, 5  
 Minimum Opening Time, 19  
 Minimum Voltage, 5  
 Mode  
     Burst, 10  
     Control, 9  
     Instrument, 9  
 Mounting, Specifications, 6

## **N**

NAMUR mounting standards, 5  
 NEPSI, China, Certification, 6  
 Non-critical NVM Alert, 35  
 NVM Failure, 24, 36

## **O**

Offline/Failed, 36  
 Operational Status, 37  
 Options, 6  
 Options Board, 4  
 Output Pressure Sensor, Calibration, 30  
 Output Signal, 5  
     Action, 5  
     Maximum Span, 5  
     Minimum Span, 5  
 Overcurrent Protection, 5

## P

Parameters  
  conditions for modifying, 13  
  Factory Default, 11

Parts  
  Kits, 49  
  Ordering, 49

PD (Performance Diagnostics), 4, 34

PED Directive 2014/38/EU, 6

Performance Diagnostics (PD), 4, 34

PESO CCOE, India, Certification, 6

Pipe-away vent option, 6

Pneumatic Connections, 3

pneumatic output signal, 56

Pneumatic Relay, 43  
  Assembly, 43  
  Removal, 43  
  Replacing, 43

Pole Piece, 4

Polling Address, 14

Position Transmitter Calibration, 31

Power Starvation Alert, 35

Pressure, Instrument Output, Value, 33

Pressure Sensor Calibration, 30

Pressure Sensor Failure, 24, 36

pressure signal, 56

Pressure Units, 15

Principle of Operation, 55  
  drive signal, 55  
  input signal, 55  
  pneumatic output signal, 56  
  pressure signal, 56

Protection, 12

## R

Record Group Enab, 23

Ref Voltage Failure, 36

Limit, Reference Accuracy, 6

Reference Voltage Failure, 24

Related Documents, 7

relay pressure range, 44

Restart Control Mode, 10

Restarting the Instrument, 10

Reverse Polarity Protection, 5

Revision Information  
  Device, 34  
  Firmware, 34  
  HART Universal, 34  
  Main Electronics, 34  
  Secondary Electronics, 34

## S

Secondary Electronics Revision, 34

Self Test Failures for Instrument Shutdown, 24

Sensor Serial Number, 34

Serial Number  
  Instrument, 14  
  Sensor, 34  
  Valve, 14

Setpoint Filter Time, 18

Setting Response, 16

Shaft Rotation, 6

Specifications, 5

Stem Travel, 6

Stroke Valve, 39

Supply Pressure, 5  
  Maximum, 16

Switch #1  
  Closed, 25  
  Trip Point, 25

Switch #2  
  Closed, 25  
  Trip Point, 25

Switches, 25

## T

Temperature, Internal, Displaying Value, 33

Temperature Compensation Failure, 24

Temperature Limits, 5

Temperature Sensor Failure, 24, 36

Temperature Units, 15

Transmitter, 6, 25  
 Fault Indication, 6  
 Reference Accuracy, 6  
 Supply Voltage, 6

Transmitter Action, 25

Transmitter/Switches, 25

Travel, 33  
 Displaying Value, 33

Travel Accumulator  
 Displaying Value, 34  
 Enabling Alert, 21  
 Resetting, 21

Travel Accumulator Alert Point, 21

Travel Accumulator Deadband, 21

Travel Alert Deadband, 21

Travel Alert High Point, 20

Travel Alert Low Point, 20

Travel Alerts, 20  
 High and Low, 20  
 High High and Low Low, 20

Travel Cutoffs  
 High, 19  
 Low, 19

Travel Deviation Alert, 21

Travel Limits  
 High, 18  
 Low, 19

Travel Sensor Failure, 24, 36

Troubleshooting, 44  
 What are the observable symptoms?, 44  
 What is a healthy unit, 44

Tuning  
 Automatic, 26  
 Damping Factor, 17  
 Integral Enable, 19  
 Manual, 26  
 Tuning Set, 16

Tuning Set, 16

Tvl Accumulation Alert, 35

Tvl Alert Hi, 35

Tvl Alert Hi Hi, 35

Tvl Alert Lo, 35

Tvl Alert Lo Lo, 35

Tvl Deviation Alrt, 35

Tvl Lim/Cutoff High, 35

Tvl Lim/Cutoff Low, 35

## V

Valve Alerts, 35  
 Alert Record has Entries, 35  
 Alert Record is Full, 35  
 Cycle Counter Alert, 35  
 Drive Signal Alert, 35  
 Instrument Time is Invalid, 35  
 Non-critical NVM Alert, 35  
 Power Starvation Alert, 35  
 Tvl Accumulation Alert, 35  
 Tvl Alert Hi, 35  
 Tvl Alert Hi Hi, 35  
 Tvl Alert Lo, 35  
 Tvl Alert Lo Lo, 35  
 Tvl Deviation Alrt, 35  
 Tvl Lim/Cutoff High, 35  
 Tvl Lim/Cutoff Low, 35

Valve Serial Number, 14

Valve Setpoint, Displaying Value, 33

VDI/VDE 3845 mounting standards, 5

Vibration Testing Method, 5

Viewing Variables, 33  
 Analog Input, Travel, Valve Set Point, Drive Signal  
 and Output Pressure, 33

Voltage Available, Checking, 46

## W

Weight, DVC2000, 6

## Z

Zero Control Signal, 15, 16, 23, 71





Neither Emerson, Emerson Automation Solutions, nor any of their affiliated entities assumes responsibility for the selection, use or maintenance of any product. Responsibility for proper selection, use, and maintenance of any product remains solely with the purchaser and end user.

Fisher, FIELDVUE, ValveLink, Tri-Loop, Rosemount are marks owned by one of the companies in the Emerson Automation Solutions business unit of Emerson Electric Co. Emerson Automation Solutions, Emerson, and the Emerson logo are trademarks and service marks of Emerson Electric Co. HART is a registered trademark of FieldComm Group. All other marks are the property of their respective owners.

The contents of this publication are presented for informational purposes only, and while every effort has been made to ensure their accuracy, they are not to be construed as warranties or guarantees, express or implied, regarding the products or services described herein or their use or applicability. All sales are governed by our terms and conditions, which are available upon request. We reserve the right to modify or improve the designs or specifications of such products at any time without notice.

Emerson Automation Solutions  
Marshalltown, Iowa 50158 USA  
Sorocaba, 18087 Brazil  
Cernay, 68700 France  
Dubai, United Arab Emirates  
Singapore 128461 Singapore

[www.Fisher.com](http://www.Fisher.com)

