

Fisher™ D and DA Valves

Contents

Introduction	1
Scope of Manual	1
Description	1
Specifications	2
Educational Services	2
Ceramic Trim	3
Installation	3
Maintenance	5
Packing Lubrication	5
Packing Maintenance	6
Replacing Packing	6
Trim Maintenance	8
Disassembly	8
Lapping Metal Seats	8
Assembly	9
Parts Ordering	9
Parts Kits	10
Parts List	10

Figure 1. Fisher D Valve with 657 Actuator



W0232

Introduction

Scope of Manual

This instruction manual includes installation, maintenance, and parts information for Fisher D and DA valves. Refer to separate manuals for instructions covering the actuator, positioner, and accessories.

Do not install, operate, or maintain a D or DA valve without being fully trained and qualified in valve, actuator, and accessory installation, operation, and maintenance. To avoid personal injury or property damage, it is important to carefully read, understand, and follow all the contents of this manual, including all safety cautions and warnings. If you have any questions about these instructions, contact your [Emerson sales office](#) or Local Business Partner before proceeding.

Unless otherwise noted, all NACE references are to NACE MR0175-2002.

Description

The D globe-style (figure 1) and DA angle-style (figure 5) valves are single-port, metal-seated valves for high-pressure applications.

Table 1. Specifications

<p>Maximum Inlet Pressures and Temperatures⁽¹⁾ If the valve nameplate shows an ASME pressure-temperature class, maximum inlet pressure and temperature is consistent with applicable ASME class per ASME B16.34. If the nameplate does not show an ASME class, it will show a maximum cold working pressure at 38°C (100°F) (for example, 3600, 6000, 9000, or 10,000 psi)</p> <p>Maximum Allowable Pressure Drops⁽¹⁾ Flow up: Capable of full rated pressure drops Flow down: See table 2 for pressure drop limits for ceramic trim</p> <p>Shutoff Classification Per ANSI/FCI 70-2 and IEC 60534-4 Standard: Class IV Optional: Class V</p>	<p>Maximum Service Temperature 232°C (450°F)</p> <p>Flow Characteristic Equal Percentage</p> <p>Flow Direction D Valve: Flow up through the seat ring and out past the valve plug DA Valve: Flow in either direction</p> <p>Approximate Weight D Valve: 34 kg (75 lbs) DA Valve: 46 kg (100 lbs)</p>
--	--

1. Do not exceed the pressure or temperature limits in this manual and any applicable standard limitations.

Specifications

Specifications for these valves are in table 1. Some of the specifications for a given valve appear on a nameplate, which is attached to the valve actuator or wired to the valve assembly if the valve was purchased without an actuator.

Educational Services

For information on available courses for Fisher D and DA valves, as well as a variety of other products, contact:

Emerson Automation Solutions
 Educational Services - Registration
 Phone: 1-641-754-3771 or 1-800-338-8158
 E-mail: education@emerson.com
 emerson.com/fishervalvetraining

Table 2. Flow Down Pressure Drop Limits - Ceramic Trim Only

VALVE SIZE NPS	SEAT RING DIAMETER, mm (INCHES)					
	6.4 (0.25)	9.5 (0.375)	12.7 (0.5)	19.1 (0.75)	25.4 (1)	31.8 (1.25)
	Pressure Drop, bar					
1	414	414	414	193	---	---
2	689	689	689	462	262	165
	Pressure Drop, psi					
1	6000	6000	6000	2800	---	---
2	10,000	10,000	10,000	6700	3800	2400

Ceramic Trim

Some types of ceramic trim, including the VTC (very tough ceramic) variety, can create a spark under certain circumstances. When the edge of a ceramic part is struck against a second ceramic part with enough force, a spark can be created.

⚠ WARNING

Avoid personal injury and property damage from ignition of process fluid caused by sparks from ceramic trim. Do not use ceramic trim where the process fluid is unstable or if it is an explosive mixture (such as ether and air).

Installation

⚠ WARNING

Always wear protective gloves, clothing, and eyewear when performing any installation operations to avoid personal injury.

To avoid personal injury or property damage resulting from the sudden release of process pressure or bursting of parts, do not install the valve assembly where service conditions could exceed the limits given in this manual or on the appropriate nameplates. Use pressure-relieving devices as required by government or accepted industry codes and good engineering practices.

Check with your process or safety engineer for any additional measures that must be taken to protect against process media.

If installing into an existing application, also refer to the WARNING at the beginning of the Maintenance section in this instruction manual.

CAUTION

When ordered, the valve configuration and construction materials were selected to meet particular pressure, temperature, pressure drop, and controlled fluid conditions. Some body/trim material combinations are limited in their pressure drop and temperature ranges. Do not apply any other conditions to the valve without first contacting your Emerson Automation Solutions sales office.

1. Before installing the valve, inspect it to be certain that the valve body cavity is free of foreign material. Clean out all pipelines to remove scale, welding slag, and other foreign materials.
2. Install the valve so that flow through the valve is in the direction shown by the arrow cast on the valve body. The control valve assembly may be installed in any position unless limited by seismic considerations. However, the normal method is with the actuator vertical above the valve. With some valves, the actuator may need support when it is not vertical. For more information, consult your [Emerson sales office](#) or Local Business Partner.
3. Use accepted piping and welding practices when installing the valve in the line. For flanged valve bodies, use suitable gaskets between the body flanges and pipeline flanges.

CAUTION

Depending on valve body materials used, post-weld heat treating might be needed. If so, damage to internal elastomeric and plastic parts, as well as internal metal parts is possible. Shrink-fit pieces and threaded connections may also loosen. In general, if post-weld heat treating is needed, remove all trim parts. Contact your [Emerson sales office](#) or Local Business Partner for additional information.

For screwed end connections, apply pipe compound to pipeline threads.

4. To allow continuous operation during inspection or maintenance, install a three-valve bypass around the control valve assembly.
5. If you received the actuator and valve body shipped separately, refer to the appropriate actuator instruction manual for the actuator mounting procedure.

Figure 2. Lubricator and Lubricator/Isolating Valve (optional)

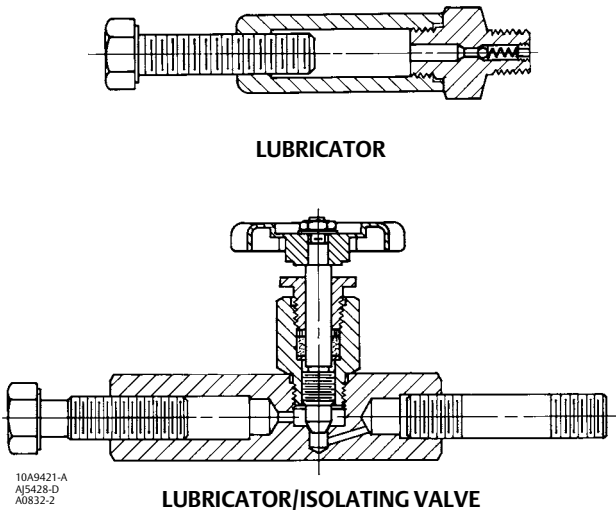
**⚠ WARNING**

Personal injury could result from packing leakage. Valve packing was tightened before shipment; however the packing might require some readjustment to meet specific service conditions.

Maintenance

⚠ WARNING

Avoid personal injury from sudden release of process pressure. Before performing any maintenance operations:

- Do not remove the actuator from the valve while the valve is still pressurized.
- Always wear protective gloves, clothing, and eyewear when performing any maintenance operations to avoid personal injury.
- Disconnect any operating lines providing air pressure, electric power, or a control signal to the actuator. Be sure the actuator cannot suddenly open or close the valve.
- Use bypass valves or completely shut off the process to isolate the valve from process pressure. Relieve process pressure on both sides of the valve. Drain the process media from both sides of the valve.
- Vent the pneumatic actuator loading pressure and relieve any actuator spring precompression.
- Use lock-out procedures to be sure that the above measures stay in effect while you work on the equipment.
- The valve packing box may contain process fluids that are pressurized, *even when the valve has been removed from the pipeline*. Process fluids may spray out under pressure when removing the packing hardware or packing rings, or when loosening the packing box pipe plug.
- Check with your process or safety engineer for any additional measures that must be taken to protect against process media.

Table 3. Bolting Torque for Packing Box Nuts (Key 15)

VALVE RATING	STEM DIAMETER		MINIMUM RECOMMENDED TORQUE		MAXIMUM RECOMMENDED TORQUE	
	mm	Inches	N•m	Lbf•in	N•m	Lbf•in
3600 psi or to CL1500	9.5	3/8	4	36	5	48
	12.7	1/2	7	66	11	96
	19.1	3/4	16	144	24	216
6000 psi or CL2500	9.5	3/8	5	42	7	60
	2.7	1/2	9	78	12	108
	19.1	3/4	20	180	30	264
9000 psi	12.7	1/2	6	54	8	72
	19.1	3/4	20	180	30	264
10,000 psi	12.7	1/2	6	54	8	72
	19.1	3/4	20	180	30	264

Valve body parts are subject to normal wear and must be inspected and replaced as necessary. Inspection and maintenance frequency depends on the severity of service conditions. This section includes instructions for packing lubrication, packing maintenance, trim maintenance, and lapping seating surfaces. All maintenance operations can be performed with the valve in the line.

Note

Whenever a gasket seal is disturbed by removing or shifting gasketed parts, install a new gasket upon reassembly. This is necessary to ensure a good gasket seal because the used gasket might not seal properly.

Packing Lubrication

The valve might have an optional lubricator or lubricator/isolating valve (figure 2) in the tapped bonnet. Use the lubricator or lubricator/isolating valve for PTFE/composition or other packings that need lubrication. Use a silicon-base

lubricant. Do not lubricate packing used in oxygen service. To operate the lubricator, turn the cap screw clockwise to force the lubricant into the packing box. The lubricator/isolating valve operates the same way except open the isolating valve before turning the cap screw. Close the isolating valve after lubrication is completed.

Packing Maintenance

Refer to figures 3, 4, and 5 for key number locations. For spring-loaded single PTFE V-ring packing, the packing spring (key 9) maintains a sealing force on the packing. If you find leakage around the packing follower (key 10), check to be sure the packing follower is touching the bonnet (key 5). If the packing follower is not touching the bonnet, tighten the packing flange nuts (key 15) until the packing follower touches the bonnet. If you cannot stop leakage in this way, proceed to the Replacing Packing procedure.

If there is unwanted packing leakage with other than spring-loaded packing, first try to limit the leakage and seal the stem. To limit the leakage, tighten the packing flange nuts (key 15) to at least the minimum recommended torque in table 3. However, do not exceed the maximum recommended torque in table 3, or excessive friction might result. If the packing (key 8) is relatively new and tight on the stem, and tightening the packing flange nuts does not stop the leakage, a worn or nicked valve stem might prevent a seal. If the leakage comes from the outside diameter of the packing, nicks or scratches around the packing box wall might cause the leakage. While replacing the packing per the numbered steps below, inspect the valve stem and packing box wall for nicks and scratches.

Replacing Packing

Except where indicated, refer to figures 3, 4, and 5 for key number locations.

⚠ WARNING

Refer to the WARNING at the beginning of the Maintenance section in this instruction manual.

1. Isolate the control valve from the line pressure, release pressure from both sides of the valve body, and drain the process media from both sides of the valve. If using a power actuator, also shut-off all pressure lines to the power actuator and any leak-off piping from the bonnet. Release all pressure from the actuator and relieve spring precompression. Use lock-out procedures to be sure that the above measures stay in effect while you work on the equipment.

Disconnect the stem connector, and then remove the actuator from the valve body by unscrewing the actuator yoke locknut (key 14).

2. Loosen the packing flange nuts (key 15) so the packing is not tight on the valve stem. Remove any travel indicator parts and stem locknuts from the valve stem threads.
3. Unscrew the bonnet (key 5) from the valve body (key 1). Carefully lift off the bonnet and valve plug/stem assembly (key 4) as a unit. Set the bonnet on a protective surface to prevent damage to the bonnet threads and gasket surface.
4. Remove the valve plug/stem assembly from the bonnet. If you plan to re-use the valve plug, tape or otherwise protect the valve plug seating surface and the stem threads to prevent damage.
5. Remove the bonnet gasket (key 7). Cover the opening in the valve body to protect the gasket surface and prevent foreign material from getting into the body cavity.
6. Remove the packing flange nuts, packing flange, upper wiper, and follower (keys 15, 12, 21, and 10). Carefully push out all the remaining packing box parts from the bonnet using a rounded rod or other tool that will not scratch the packing box wall or bottom guide bushing. Clean the packing box and the metal packing box parts.
7. Inspect the valve stem threads and packing box surfaces for any sharp edges that might cut the packing. Scratches or burrs could cause packing box leakage or damage to the new packing. If you cannot improve the surface condition by light sanding, replace the damaged parts.

Figure 3. Packing Arrangements

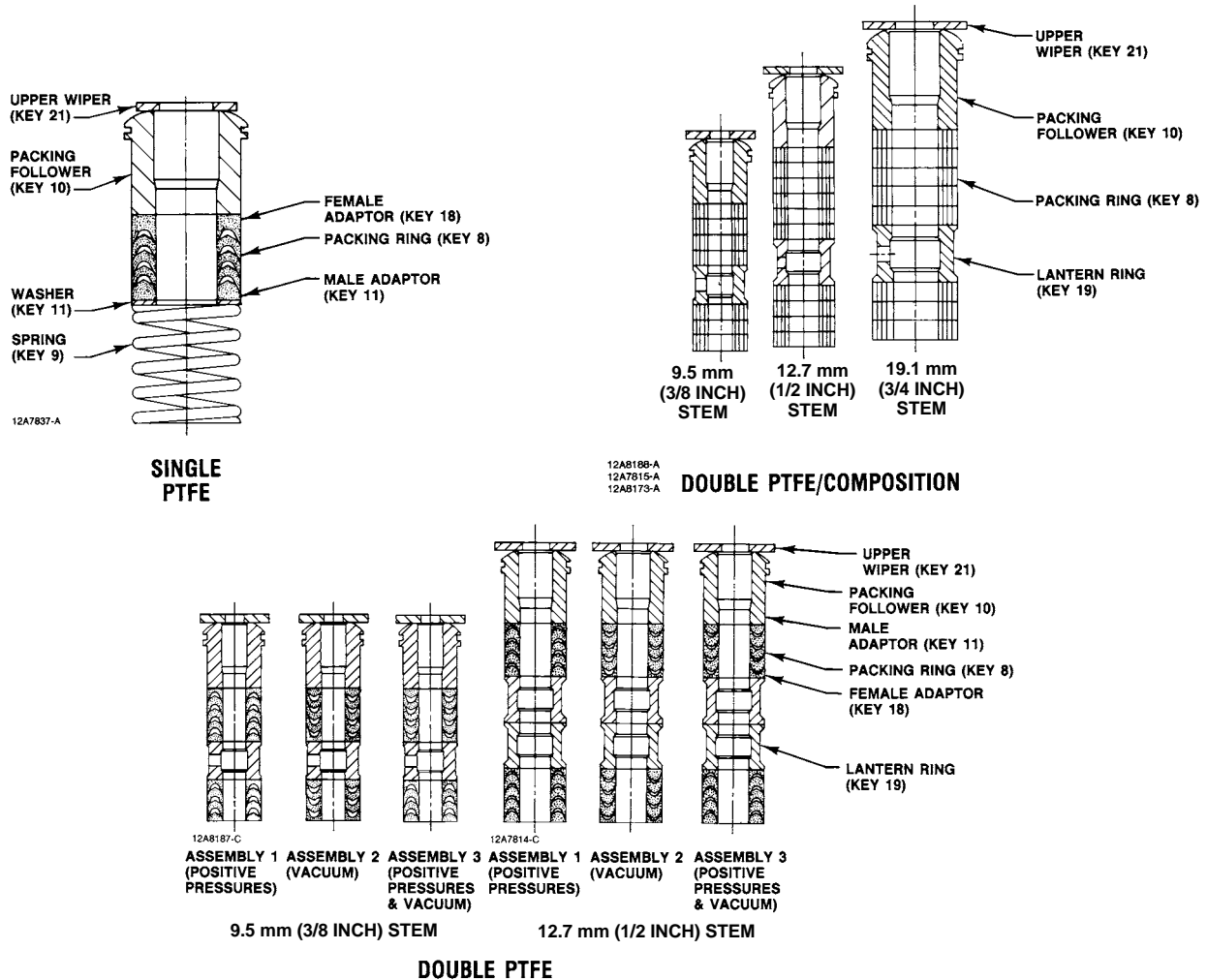

C0755-1

8. Install a new bonnet gasket (key 7), making sure the gasket seating surfaces are clean and smooth. Carefully install the valve plug/stem assembly into the valve body. Then slide the bonnet over the stem and thread it tightly into the valve body, per the torque values in table 4.
9. Install new packing and the metal packing box parts according to the correct arrangement in figure 3. Place a smooth-edged pipe over the valve stem, and gently tap each soft packing part into the packing box.

Table 4. Torque for Body-to-Bonnet Joint

VALVE SIZE	RECOMMENDED TORQUE	
	N•m	Lbf•ft
NPS 1	1060	780
NPS 2 - Up to 6000 psi valve rating	2030	1500
NPS 2 - 9000 ⁽¹⁾ and 10,000 psi valve rating	2710	2000

1. 9000 psi valve rating is available for DA only.

Table 5. Torque for Seat Ring (Key 2)

VALVE SIZE, NPS	RECOMMENDED TORQUE	
	N•m	Lbf•ft
1	407	300
2	698	515

- Slide the packing follower, upper wiper, and packing flange (keys 10, 21, and 12) into position. Lubricate the packing flange studs (key 13) and the faces of the packing flange nuts (key 15). Install the packing flange nuts.
- For spring-loaded PTFE V-ring packing, tighten the packing flange nuts (key 15) until the packing follower (key 10) contacts the bonnet. For other packing arrangements, tighten the packing flange nuts (key 15) alternately in small equal increments. Continue until one of the nuts reaches the minimum recommended torque shown in table 3. Then tighten the remaining packing flange nut until the packing flange is level and at a 90-degree angle to the valve stem.
- Mount the actuator on the bonnet (key 5) and connect the actuator and valve plug stem according to the procedure in the appropriate actuator instruction manual. Check for leakage around the packing follower when you put the control valve assembly into service. Retighten the packing flange nuts as required.

Trim Maintenance

Refer to figure 4 and 5 for key number locations.

Disassembly

- Remove the actuator and the bonnet as described in steps 1 through 3 of the Replacing Packing procedure.

CAUTION

Use care to avoid damaging the gasket sealing surfaces.

The stem surface finish of the valve plug/stem assembly (key 4) is critical for making a good packing seal. The seating surfaces of the seat ring (key 2) and the plug of the valve plug/stem assembly (key 4) are critical for tight shutoff. Protect these parts from damage if you plan to re-use them in the valve.

- If you wish, remove the valve plug/stem assembly (key 4) and the packing parts from the bonnet. If you plan to re-use the valve plug, tape or otherwise protect the valve plug seating surface and the stem threads to prevent damage. Remove the packing parts as described in the Packing Maintenance procedure.
- Use a socket wrench to remove the seat ring (key 2).
- Remove the seat ring (key 2) and seat ring gasket (key 3) from the valve body.
- Inspect parts for wear or damage that would prevent proper operation of the valve body. Clean the gasket surfaces.
- Replace trim parts as necessary or use the Lapping Metal Seats procedure.

Lapping Metal Seats

A certain amount of leakage should be expected with metal-to-metal seating in any valve body. If the leakage becomes excessive, however, the condition of the seating surfaces of the valve plug and seat ring (keys 4 and 2, figures 4 and 5) can be improved by lapping. (Deep nicks should be machined out rather than ground out.) Use a good quality lapping compound of a mixture of 280 to 600-grit. Apply the compound to the bottom of the valve plug.

Partially assemble the valve so the seat ring and valve plug are in place and the bonnet (with bushing installed) is screwed hand-tight into the body. Make a simple handle from a piece of strap iron locked to the valve plug stem with

nuts. Rotate the handle alternately in each direction with light downward pressure to lap the seats. If you think there is not enough lubrication (for example, if you hear a squeaking noise or feel vibration), stop the procedure, and apply more lapping compound before continuing. After lapping, remove the bonnet and valve plug/stem assembly as a unit, and clean the seating surfaces. Completely assemble as described in the Assembly portion of the Trim Maintenance procedure.

Test the valve for shutoff. Repeat the lapping procedure if leakage is still excessive.

Assembly

1. Thoroughly clean the seat ring and bonnet threads in the valve body (key 1). Also clean the valve body seat ring gasket surfaces.
2. Apply anti-seize lubricant to the threads of the seat ring (key 2), bonnet (key 5), and their mating threads in the body.
3. Put the seat ring gasket (key 3) into the body.
4. Screw the seat ring into the body. Use a socket wrench to tighten the seat ring to the torque values shown in table 4. Remove all excess lubricant after tightening.
5. Clean the bonnet gasket seating surfaces, and install a new bonnet gasket (key 7).
6. If you had not removed the valve plug/stem assembly and packing from the bonnet, then install the bonnet (key 5) and valve plug/stem assembly (key 4) as a unit, into the valve body. Keeping the valve plug/stem assembly in an “up” position, thread the bonnet tightly into the valve body, per torque values in table 4.
7. If you had previously chosen to remove the valve plug/stem assembly and packing from the bonnet, then remove any protective tape or covering from the valve plug/stem assembly (key 4) and carefully install it into the valve body. Slide the bonnet (key 5) over the stem and thread it tightly into the valve body. Install new packing and the metal packing box parts according to the correct arrangement in figure 3. Place a smooth-edged pipe over the valve stem, and gently tap each soft packing part into the packing box.
8. Slide the packing follower, upper wiper, and packing flange (keys 10, 21, and 12) into position. Lubricate the packing flange studs (key 13) and the washer surfaces of the packing flange nuts (key 15). Install the packing flange nuts.
9. For spring-loaded PTFE V-ring packing, tighten the packing flange nuts (key 15) until the packing follower (key 10) contacts the bonnet. For other packing arrangements, tighten the packing flange nuts (key 15) alternately in small equal increments. Continue until one of the nuts reaches the minimum recommended torque shown in table 3. Then tighten the remaining packing flange nut until the packing flange is level and at a 90-degree angle to the valve stem.
10. Mount the actuator on the bonnet (key 5) and connect the actuator and valve plug stem according to the procedure in the appropriate actuator instruction manual. Check for leakage around the packing follower (key 10) when you put the control valve assembly into service. Retighten the packing flange nuts as required.

Parts Ordering

Each body-bonnet assembly is assigned a serial number, which is on the body or nameplate. The serial number also appears on the actuator nameplate if you bought a valve and actuator assembly. Refer to this serial number when contacting your [Emerson sales office](#) or Local Business Partner for technical advice. When ordering replacement parts, mention the serial number. Also specify key number, part description, material, and part number from the following lists of Parts Kits and part numbers.

▲ WARNING

Use only genuine Fisher replacement parts. Components that are not supplied by Emerson Automation Solutions should not, under any circumstances, be used in any Fisher valve, because they may void your warranty, might adversely affect the performance of the valve, and could cause personal injury and property damage.

Parts Kits

Key	Description	Part Number
---	Packing Box Parts for Double PTFE V-Ring Packing (Includes keys 3, 7, 8, 11, 18, 19, and 21)	
	9.5 mm (3/8 Inch) Stem	RDX0000CN12
	12.7 mm (1/2 Inch) Stem	RDX0000CN22
---	Trim Package (S31600) [Includes Equal Percentage S31600 (316 SST) W/R30006 (alloy 6) tip valve plug/stem (key 4), S316000 w/alloy 6 seat ring (key 2), stainless steel gaskets (keys 3 & 7), and single PTFE packing parts (keys 8, 9, 11, 17, 18, and 21) or double PTFE packing parts (keys 8, 11, 18, 19, and 21)]	
	Double PTFE V-Ring Packing	
	NPS 1 Valve w/ 9.5 mm (3/8 Inch) Stem Dia.	
	6.4 mm (0.25 Inch) port dia.	RDXCNTRM112
	9.5 mm (0.375 Inch) port dia.	RDXCNTRM122
	12.7 mm (0.5 Inch) port dia.	RDXCNTRM132
	19.1 mm (0.75 Inch) port dia.	RDXCNTRM142
	NPS 2 Valve w/ 12.7 mm (1/2 Inch) Stem Dia.	
	6.4 mm (0.25 Inch) port dia.	RDXCNTRM212
	9.5 mm (0.375 Inch) port dia.	RDXCNTRM222
	12.7 mm (0.5 Inch) port dia.	RDXCNTRM232
	19.1 mm (0.75 Inch) port dia.	RDXCNTRM242
	25.4 mm (1-Inch) port dia.	RDXCNTRM252
	31.8 mm (1.25 Inch) port dia.	RDXCNTRM262
---	Trim Package (Ceramic) Includes seat ring and valve plug/stem assy (keys 2 and 4)	
	NPS 1 Valve w/ 9.5 mm (3/8 Inch) Stem Dia.	
	6.4 mm (0.25 Inch) port dia.	RDXVTC00012
	9.5 mm (0.375 Inch) port dia.	RDXVTC00022
	12.7 mm (0.5 Inch) port dia.	RDXVTC00032
	19.1 mm (0.75 Inch) port dia.	RDXVTC00042
	NPS 2 Valve w/ 12.7 mm (1/2 Inch) Stem Dia.	
	6.4 mm (0.25 Inch) port dia.	RDXVTC00052
	9.5 mm (0.375 Inch) port dia.	RDXVTC00062
	12.7 mm (0.5 Inch) port dia.	RDXVTC00072
	19.1 mm (0.75 Inch) port dia.	RDXVTC00082
	25.4 mm (1-Inch) port dia.	RDXVTC00092
	31.8 mm (1.25 Inch) port dia.	RDXVTC00102

Parts List

Note

Part numbers are shown for recommended spares only. For part numbers not shown, contact your [Emerson sales office](#) or Local Business Partner.

Note

Abbreviations used in this parts list are: SST (stainless steel), RTJ (ring-type joint), RF (raised face), SCH (schedule), BWE (butt welding end), dia. (diameter), in. (inches), mm (millimeters), psi (pounds per square inch), and zn pl (zinc plated).

Sizes shown in inches are valve sizes unless otherwise stated.

Select parts titled 3600 PSI if your valve has a CL1500 or lower rating and select parts titled 6000 PSI if your valve has a CL2500 rating.

Key	Description	Part Number
001	Valve Body If you need a valve body as a replacement part, order by valve size, serial number, and desired material.	
002*	Seat Ring	
	CF8M or S31600 (316 SST) w/COCR-A seat	
	NPS 1 valve	
	6.4 mm (0.25 inch) port dia.	2B5097X0012
	9.5 mm (0.375 inch) port dia.	2B5098X0012
	12.7 mm (0.5 inch) port dia.	2B5099X0012
	19.1 mm (0.75 inch) port dia.	2B5100X0012
	NPS 2 valve	
	6.4 mm (0.25 inch) port dia.	2B5106X0012
	9.5 mm (0.375 inch) port dia.	2B5107X0012
	12.7 mm (0.5 inch) port dia.	2B5108X0012
	19.1 mm (0.75 inch) port dia.	2B5109X0012
	25.4 mm (1-inch) port dia.	2B5110X0012
	31.8 mm (1.25 inch) port dia.	2K1801X0012
	316 SST w/tungsten carbide insert	
	NPS 1 valve	
	6.4 mm (0.25 inch) port dia.	1J6886000A2
	9.5 mm (0.375 inch) port dia.	1J6887000A2
	12.7 mm (0.5 inch) port dia.	1J6888000A2
	19.1 mm (0.75 inch) port dia.	1J6889000A2
	NPS 2 valve	
	6.4 mm (0.25 inch) port dia.	1J6899000A2
	9.5 mm (0.375 inch) port dia.	1J8154000A2
	12.7 mm (0.5 inch) port dia.	1J8156000A2
	25.4 mm (1-inch) port dia.	1J8160000A2
	Ceramic	
	NPS 1 valve	
	6.4 mm (0.25 inch) port dia.	22B8996X012
	9.5 mm (0.375 inch) port dia.	22B8997X012
	12.7 mm (0.5 inch) port dia.	22B8998X012
	19.1 mm (0.75 inch) port dia.	22B8999X012
	NPS 2 valve	
	6.4 mm (0.25 inch) port dia.	22B9000X012
	9.5 mm (0.375 inch) port dia.	22B9001X012
	12.7 mm (0.5 inch) port dia.	22B9002X012
	19.1 mm (0.75 inch) port dia.	22B9003X012
	25.4 mm (1-inch) port dia.	22B9004X012
	31.8 mm (1.25 inch) port dia.	22B9005X012

Key	Description	Part Number	Key	Description	Part Number
003*	Gasket			12.7 mm (0.5 inch) port dia.	22B8966X012
	S31600 (316 SST)			19.1 mm (0.75 inch) port dia.	22B8967X012
	For NPS 1 valves and NACE MR0175-2002 ⁽¹⁾	1B198636042		NPS 2 valve, 12.7 mm (1/2 in) stem	
	For NPS 2 valves and NACE MR0175-2002 ⁽¹⁾	1B198836042		6.4 mm (0.25 inch) port dia.	22B8968X012
004*	Micro-Flute valve plug/stem assembly			9.5 mm (0.375 inch) port dia.	22B8969X012
	NACE MR0175-2002 ⁽¹⁾ S31600, COCR-A seat - S20910			12.7 mm (0.5 inch) port dia.	22B8970X012
	NPS 1 valve, 9.5 mm (3/8 in.) stem			19.1 mm (0.75 inch) port dia.	22B8971X012
	1 flute			25.4 mm (1-inch) port dia.	22B8972X012
	6.4 mm (0.25 inch) port dia.	2N7147X0032		31.8 mm (1.25 inch) port dia.	22B8973X012
	3 flutes			NPS 2 valve, 19.1 mm (3/4 inch) stem	
	6.4 mm (0.25 inch) port dia.	2F3280X0022		6.4 mm (0.25 inch) port dia.	22B8974X012
	9.5 mm (0.375 inch) port dia.	2N7389X0022		9.5 mm (0.375 inch) port dia.	22B8975X012
	12.7 mm (0.5 inch) port dia.	2N7338X0022		12.7 mm (0.5 inch) port dia.	22B8976X012
	19.1 mm (0.75 inch) port dia.	2N7393X0022		19.1 mm (0.75 inch) port dia.	22B8977X012
004*	Equal percentage valve plug/stem assembly			25.4 mm (1-inch) port dia.	22B8978X012
	S31600 (316 SST) w/S20910 (22-13-5) & Alloy 6 for			31.8 mm (1.25 inch) port dia.	22B8979X012
	NACE MR0175-2002 ⁽¹⁾		005	Bonnet/Bushing Assy	
	NPS 1 valve, 9.5 mm (3/8 in.) stem			If you need a bonnet as a replacement part, order by valve size	
	6.4 mm (0.25 inch) port dia.	2F1388X0042		and stem diameter, serial number, and desired material.	
	9.5 mm (0.375 inch) port dia.	2F1389X0032	007*	Gasket	
	12.7 mm (0.5 inch) port dia.	2F1390X0032		S31600 (316 SST)	
	19.1 mm (0.75 inch) port dia.	2F1391X0032		For NPS 1 valves and NACE MR0175-2002 ⁽¹⁾	1B198236042
	NPS 2 valve, 12.7 mm (1/2 in.) stem			For NPS 2 valves and NACE MR0175-2002 ⁽¹⁾	1B198436042
	6.4 mm (0.25 inch) port dia.	2F1427X0022	008*	Packing Ring	
	9.5 mm (0.375 inch) port dia.	2F1428X0022		Double PTFE/Composition packing	
	12.7 mm (0.5 inch) port dia.	2F1429X0022		9.5 mm (3/8 in.) stem (7 req'd)	1F3370X0012
	19.1 mm (0.75 inch) port dia.	2F1430X0022		12.7 mm (1/2 in.) stem (10 req'd)	1E319001042
	25.4 mm (1-inch) port dia.	2F1431X0022		19.1 mm (3/4 in.) stem (8 req'd)	1E319101042
	31.8 mm (1.25 inch) port dia.	2L5331X0032		Double PTFE V-Ring	
	S31600 (316 SST) w/tungsten carbide tip for NACE			9.5 mm (3/8 in.) stem (6 req'd)	1C752601012
	MR0175-2002 ⁽¹⁾			12.7 mm (1/2 in.) stem (6 req'd)	1C752701012
	NPS 1 valve, 9.5 mm (3/8 in.) stem		010	Packing Follower	
	6.4 mm (0.25 inch) port dia.	2J6894X0022	011*	Packing Adaptor, male	
	9.5 mm (0.375 inch) port dia.	2J6895X0022		Double PTFE V-Ring packing	
	12.7 mm (0.5 inch) port dia.	2J6896X0022		9.5 mm (3/8 in.) stem (2 req'd)	1F124801012
	19.1 mm (0.75 inch) port dia.	2J6897X0022		12.7 mm (1/2 in.) stem (2 req'd)	1F124701012
	NPS 2 valve, 12.7 mm (1/2 in.) stem			19.1 mm (3/4 in.) stem (2 req'd)	1F124601012
	6.4 mm (0.25 inch) port dia.	2J8189X0022	012	Packing Flange	
	9.5 mm (0.375 inch) port dia.	2J8191X0022	013	Packing Box Stud	
	12.7 mm (0.5 inch) port dia.	2J8193X0022	014	Yoke Locknut, steel	
	19.1 mm (0.75 inch) port dia.	2J8195X0022	015	Hex Nut	
	25.4 mm (1-inch) port dia.	2J8197X0052	016	Pipe Plug	
	31.8 mm (1.25 inch) port dia.	2V2234X0022	016	Stem Lubricator/Isolating Valve	
	Ceramic		016	Pipe Nipple, for lubricator/isolating valve	
	NPS 1 valve, 9.5 mm (3/8 in) stem		016	Stem Lubricator	
	6.4 mm (0.25 inch) port dia.	22B8956X012	018*	Packing Adaptor, female	
	9.5 mm (0.375 inch) port dia.	22B8957X012		Double PTFE V-Ring	
	12.7 mm (0.5 inch) port dia.	22B8958X012		9.5 mm (3/8 in.) stem (2 req'd)	1F124401012
	19.1 mm (0.75 inch) port dia.	22B8959X012		12.7 mm (1/2 in.) stem (2 req'd)	1F124301022
	NPS 1 valve, 12.7 mm (1/2 inch) stem			19.1 mm (3/4 in.) stem (2 req'd)	1F124201012
	6.4 mm (0.25 inch) port dia.	22B8960X012	019	Lantern Ring	
	9.5 mm (0.375 inch) port dia.	22B8961X012	021*	Upper Wiper, felt	
	12.7 mm (0.5 inch) port dia.	22B8962X012		9.5 mm (3/8 in.) stem	1J872606332
	19.1 mm (0.75 inch) port dia.	22B8963X012		12.7 mm (1/2 in.) stem	1J872706332
	NPS 1 valve, 19.1 mm (3/4 in) stem			19.1 mm (3/4 in.) stem	1J872806332
	6.4 mm (0.25 inch) port dia.	22B8964X012	025	Seal & Wire (not shown), lead	
	9.5 mm (0.375 inch) port dia.	22B8965X012		Required only if actuator is not furnished	
			- - -	Tag,warning (not shown)	

*Recommended spare parts

1. These materials are listed in NACE standard MR0175-2002 as being acceptable for direct exposure to sour environment when used under conditions stated in that standard.

Figure 4. Fisher D Globe-Style Valve

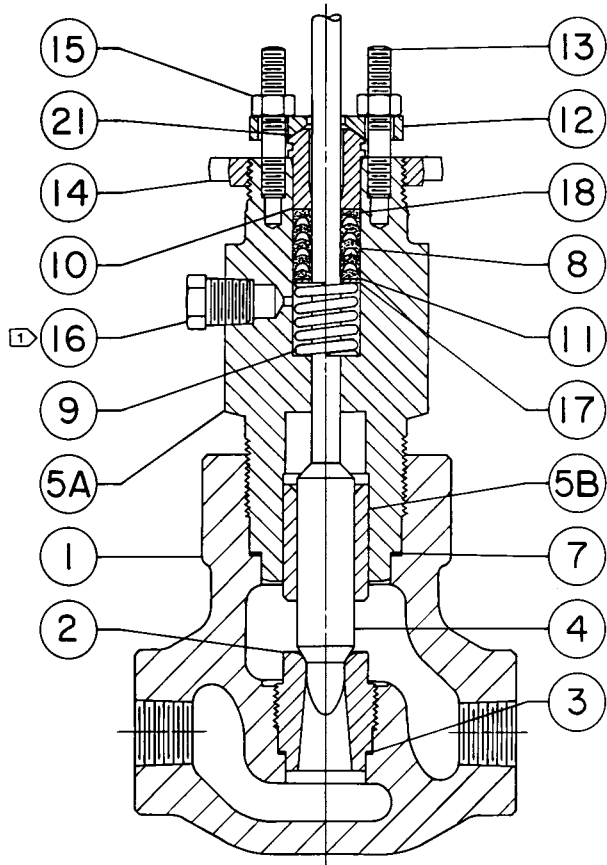

NOTE:
 1 PIPE PLUG (KEY 16) INCLUDED ONLY IF BONNET IS DRILLED AND TAPPED FOR PACKING LUBRICATOR AND LUBRICATOR IS NOT INSTALLED.

BF2007-F
 AS862-1

Figure 5. Fisher DA Angle-Style Valve

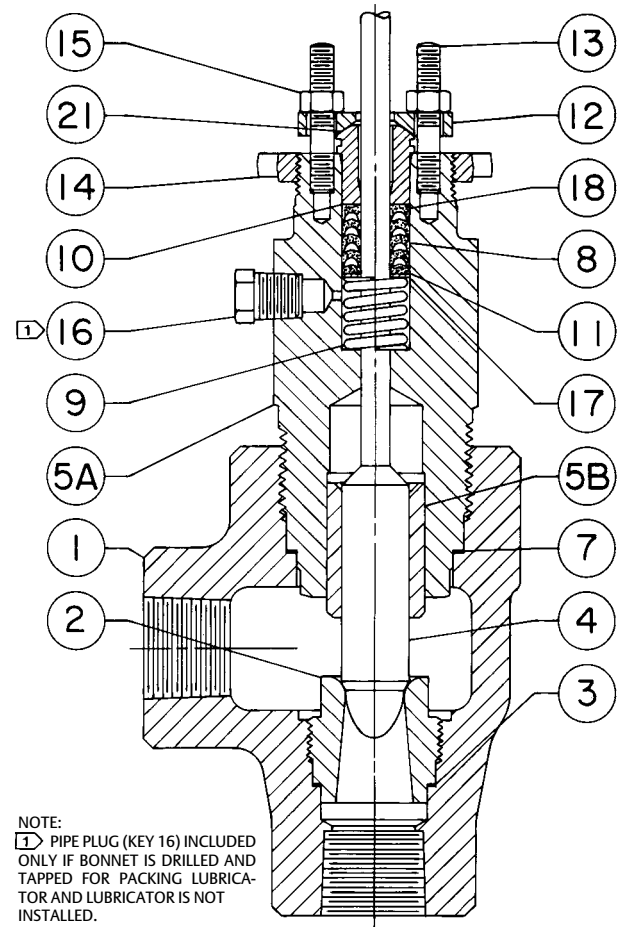

NOTE:
 1 PIPE PLUG (KEY 16) INCLUDED ONLY IF BONNET IS DRILLED AND TAPPED FOR PACKING LUBRICATOR AND LUBRICATOR IS NOT INSTALLED.

BF2035-D
 AS861-1

Neither Emerson, Emerson Automation Solutions, nor any of their affiliated entities assumes responsibility for the selection, use or maintenance of any product. Responsibility for proper selection, use, and maintenance of any product remains solely with the purchaser and end user.

Fisher is a mark owned by one of the companies in the Emerson Automation Solutions business unit of Emerson Electric Co. Emerson Automation Solutions, Emerson, and the Emerson logo are trademarks and service marks of Emerson Electric Co. All other marks are the property of their respective owners.

The contents of this publication are presented for informational purposes only, and while every effort has been made to ensure their accuracy, they are not to be construed as warranties or guarantees, express or implied, regarding the products or services described herein or their use or applicability. All sales are governed by our terms and conditions, which are available upon request. We reserve the right to modify or improve the designs or specifications of such products at any time without notice.

Emerson Automation Solutions
 Marshalltown, Iowa 50158 USA
 Sorocaba, 18087 Brazil
 Cernay 68700 France
 Dubai, United Arab Emirates
 Singapore 128461 Singapore

www.Fisher.com

