

Enhanced ENVIRO-SEAL™ Packing Systems for Fisher™ Rotary Valves

Contents

Introduction	1
Scope of Manual	1
Valve/Actuator Shaft Coupler	2
Description	2
Installation	3
Removing the Actuator	3
Installing an ENVIRO-SEAL Packing System	4
Other Considerations	11
Parts Ordering	13
Parts Kits	13
Retrofit Kits	13
Repair Kits	16

Figure 1. Typical Enhanced ENVIRO-SEAL Packing Systems



W5882-1

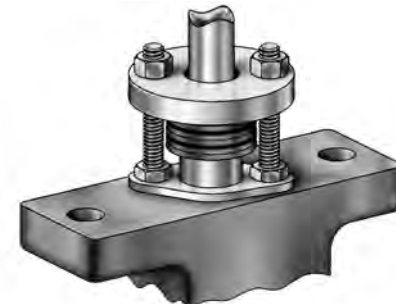

W9058-1

Introduction

Scope of Manual

This instruction manual includes installation and parts information for Fisher enhanced ENVIRO-SEAL live-loaded packing systems (see figure 1). These systems are available for Fisher rotary valves with 12.7 through 88.9 mm (1/2 through 3-1/2 inch) shaft diameters. The system can be used with many rotary valves, as shown in tables 1 and 3. Refer to appropriate valve and actuator instruction manuals for necessary information relating to the disassembly and assembly of the valve and actuator. Enhanced ENVIRO-SEAL packing systems utilize a Belleville (coned-disk) spring system.



Do not install, operate, or maintain the enhanced ENVIRO-SEAL packing systems, valve, actuator or accessories without being fully trained and qualified in valve, actuator, and accessory installation, operation, and maintenance. To avoid personal injury or property damage, it is important to carefully read, understand, and follow all the contents of this manual, including all safety cautions and warnings. If you have any questions about these instructions, contact your [Emerson sales office](#) before proceeding.

Table 1. Specifications

<p>Applicable Valve Designs^(3,4) Fisher 8560 and 8532 eccentric disk control valves; A11 control valves; V150, V200 and V300 Vee-Ball™ control valves (Series B and Non-Series B⁽¹⁾); V250 and V260 and BV500, CV500 and V500 eccentric plug rotary valves. Also see table 3.</p>	<p>Applicable Shaft Diameters See table 3</p> <p>Pressures and Temperatures⁽²⁾ See table 2</p>
---	---

1. Refer to Fisher Vee-Ball V150, V200, and V300 instruction manual, for distinctions between Series B and Non-Series B.
2. The pressure/temperature limits in this manual, in the valve literature, and any applicable code or standard limitation should not be exceeded.
3. Whenever 8532 is referenced, A31A and A31D can be applied.
4. Whenever 8560 is referenced, A41, 8510, 8510B can be applied.

Table 2. Maximum Application Temperature and Pressure for 50 PPM Service

ENVIRO-SEAL PACKING MATERIAL	MAXIMUM APPLICATION TEMPERATURE		MAXIMUM APPLICATION PRESSURE
	°C	°F	
Single PTFE	232	450	Not Restricted ⁽¹⁾
Double PTFE ⁽²⁾	177	350	20.7 bar (300 Psi)
Graphite	316	600	Not Restricted ⁽¹⁾

1. For pressure ratings through CL600 of valves listed in this instruction manual.
 2. These application conditions apply for double PTFE only in the valve types where double PTFE is available.

Valve/Actuator Shaft Coupler

To install an enhanced ENVIRO-SEAL packing system on an A11 or 8532 valve with a non-standard, non-Fisher produced actuator may require a special valve/actuator shaft coupler.

Table 10 contains a list of valve/actuator combinations and part numbers for the new coupler. If you are considering installation of an enhanced ENVIRO-SEAL packing system in another existing valve/actuator package, check table 10 to see if a new coupler is required.

In some cases, coupler replacement is not required when retrofitting valve/actuator combinations. Table 11 contains a list of valve/actuator combinations that can use existing couplers.

Description

Fisher packing systems are offered with exceptional sealing capabilities that you can easily install in existing valves or that you can purchase with new valves. These systems help you conserve valuable process fluid. The external live-loading provides a constant load over the life of the packing material, which reduces the need for packing box adjustment and maintenance.

The system design, coupled with very smooth shaft finishes and spring-loading of the packing, provides longer service with lower maintenance than many other designs.

Installation

Use these instructions to install enhanced ENVIRO-SEAL packing in valves that have standard packing, or when inspecting or replacing ENVIRO-SEAL packing.

If you are changing the packing system material from standard graphite to ENVIRO-SEAL graphite or ENVIRO-SEAL PTFE packing, the packing friction for ENVIRO-SEAL packing will be lower than it was for the standard packing. Therefore, no change should be needed in actuator sizing.

If you are changing the packing system material from standard PTFE to ENVIRO-SEAL graphite or ENVIRO-SEAL PTFE packing, the packing friction will increase. Contact your [Emerson sales office](#) to determine if your existing actuator will be large enough.

⚠ WARNING

Always wear protective gloves, clothing and eyewear when performing any maintenance operations to avoid personal injury.

To avoid personal injury or property damage resulting from the sudden release of pressure, do not install the valve assembly where service conditions could exceed the limits given in this manual, the appropriate valve instruction manual, or the limits on the appropriate name plates. Use pressure relieving devices as required by government or accepted industry codes and good engineering practices.

Check with your process or safety engineer for any additional measures that must be taken to protect against process media.

If installing into an existing application, also refer to the WARNING at the beginning of the Removing the Actuator section in this instruction manual.

Removing the Actuator

⚠ WARNING

Avoid personal injury from sudden release of process pressure or uncontrolled movement of parts. Before performing any maintenance operations:

- Do not remove the actuator from the valve while the valve is still pressurized.
- Always wear protective gloves, clothing and eyewear when performing any maintenance operations to avoid personal injury.
- Disconnect any operating lines providing air pressure, electric power, or a control signal to the actuator. Be sure the actuator cannot suddenly open or close the valve.
- Use bypass valves or completely shut off the process to isolate the valve from process pressure. Relieve process pressure on both sides of the valve. Drain the process media from both sides of the valve.
- Vent the power actuator loading pressure and relieve any actuator spring precompression.
- Use lock-out procedures to be sure that the above measures stay in effect while you work on the equipment.
- The valve packing box may contain process fluids that are pressurized, *even when the valve has been removed from the pipeline*. Process fluids may spray out under pressure when removing the packing hardware or packing rings, or when loosening the packing box pipe plug.
- Check with your process or safety engineer for any additional measures that must be taken to protect against process media.

You must remove the actuator from the valve when you install enhanced ENVIRO-SEAL packing systems. To allow proper readjustment of the valve disk position, it is recommended that you remove the valve from the pipeline. Refer to appropriate valve and actuator instruction manuals.

⚠ WARNING

If a spring-return actuator is used, be sure the actuator spring is resting on its travel stop. If something is obstructing shaft rotation, it is possible that disconnecting the shaft connector will allow the spring to force the actuator to the end of its rotation, resulting in possible personal injury or property damage. Refer to the appropriate valve and actuator instruction manuals to remove the actuator.

Installing an enhanced ENVIRO-SEAL Packing System

Note

When installing an enhanced ENVIRO-SEAL packing system into an insulated valve, do not cover the packing springs with insulation.

Note

The valve shaft surface condition is critical in obtaining a good seal. If the valve shaft surface is scratched, nicked, or worn, replace the valve shaft before installing the enhanced ENVIRO-SEAL Packing System.

Refer to the appropriate valve instruction manual to replace the valve shaft.

Key number locations are shown in figures 2 and 4 for Vee-Ball, eccentric plug, 8560, and A41 valves, and in figures 3 and 5 for A11 and 8532 valves.

1. If you are installing an enhanced ENVIRO-SEAL packing system in an existing valve, remove existing packing nuts, packing flange, jam nuts, anti-blowout flange, packing follower, and any other external packing components from the valve body.

⚠ WARNING

To avoid personal injury from packing leakage, take care when removing the old packing parts from the packing box. Do not scratch, nick or dent the valve shaft surface or packing box wall.

2. For A11, 8532, 8580, 8590, and Control-Disk valves, remove the anti-blowout wire that surrounds the valve shaft.
3. For all valves, remove packing and all other internal components from the packing box.
4. Inspect the existing valve shaft. If necessary, replace the valve shaft. Refer to the appropriate valve instruction manual to replace the valve shaft.

Figure 2. Typical Enhanced ENVIRO-SEAL Rotary Packing Arrangements with PTFE Packing for Fisher Vee-Ball, Eccentric Plug, and 8560 Valves

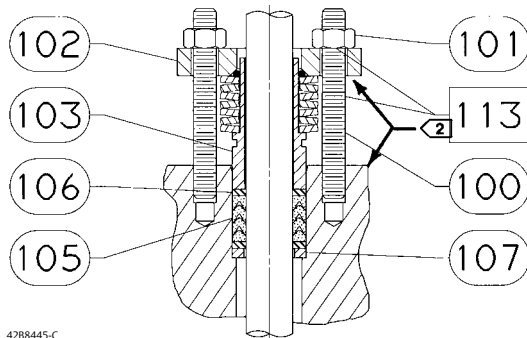

4288445-C

**SINGLE PTFE PACKING
STANDARD DEPTH BOX**

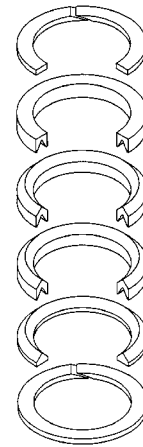

1480095-A

**STACKING ORDER
PTFE PACKING RINGS**

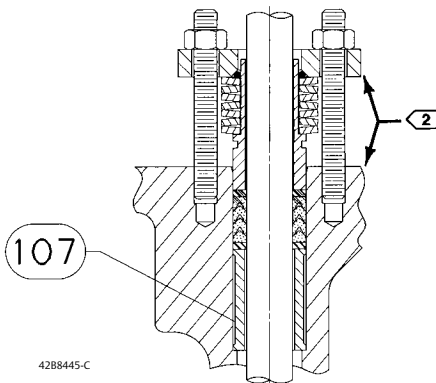

4288445-C

**SINGLE PTFE PACKING
OPTIONAL DEEP PACKING BOX
V500**

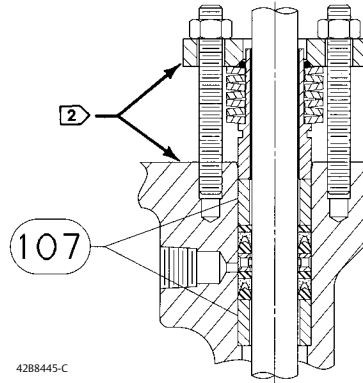

4288445-C

**DOUBLE PTFE PACKING WITH LEAKOFF
OPTIONAL DEEP PACKING BOX
V500, CV500**

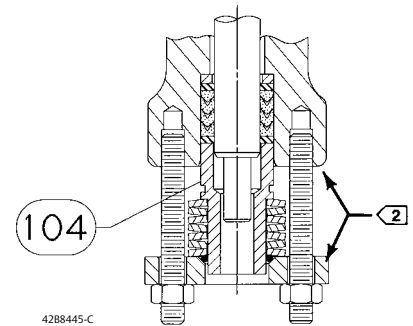

4288445-C

**SINGLE PTFE PACKING, OUTBOARD
STANDARD DEPTH BOX
8510B**

NOTES:

- ① APPLY LUBRICANT
- ② THESE TWO SURFACES MUST REMAIN PARALLEL AS YOU ALTERNATELY AND EVENLY TIGHTEN THE PACKING NUTS (KEY 101)

Note

Enhanced ENVIRO-SEAL PTFE packing systems can be used in either vacuum or positive pressure service. It is not necessary to reverse ENVIRO-SEAL PTFE packing components in vacuum service.

Make sure that the Belleville springs are stacked properly and packing box parts are assembled in the correct order (see figure 6). Packing parts cannot function properly if the Belleville springs or other packing parts are not stacked correctly.

5. With the shaft in place in the valve, install the packing parts into the valve packing box.

Note

Be sure to install the packing rings in the sequence shown in figures 2 through 5.

- a. Place one of the packing box rings (key 107) into the packing box. Be sure the packing box ring is properly seated. This does not apply to NPS 3, 4 and 6 CL600 A11 valves.
- b. For PTFE packing, place an anti-extrusion washer (key 106) into the packing box and push it in until it rests next to the packing box ring (key 106 is not used with graphite packing).

Note

The graphite packing set has a carbon anti-extrusion ring on the top and bottom of the packing. These anti-extrusion rings are designed to have a slight interference fit on the shaft. The rings have a single fracture to allow the ring to be installed on the shaft. Additional fractures may develop while the valve is in service, however, these additional fractures will not affect the performance of the ENVIRO-SEAL packing.

- c. Place the packing set (key 105) into the packing box. Refer to figure 3 or 5 for the proper orientation of the packing set.
 - d. For PTFE packing, place another anti-extrusion washer (key 106) into the packing box after the packing set (key 106 is not used with graphite packing).
 - e. Place the second packing box ring (key 107) into the packing box.
 - f. Locate the new spring pack assembly (key 103). Remove the O-ring and packing springs from the packing follower. Use the packing follower to press the packing components into the packing box. Remove the packing follower.
6. For A11, 8532, 8580, 8590, and Control-Disk valves, install the anti-blowout wire (key 16) in the groove around the valve shaft.
 7. Slide the packing follower from the new spring pack assembly over the valve shaft and the anti-blowout wire until it rests against the packing box ring.
 8. For all valves, install the longer packing studs (key 100).
 9. For A11, 8532, 8580, 8590, and Control-Disk valves, install the new anti-blowout flange (key 10) over the valve shaft, packing studs, and packing follower. Secure the anti-blowout flange with the new jam nuts (key 17).
 10. For all valves, install the spring pack assembly (key 103 or 104) which includes the Belleville springs, packing follower, and O-ring arranged as shown in figures 2 through 6. (The O-ring is a non-functional part and is used to retain the packing springs during assembly.)

Figure 3. Enhanced ENVIRO-SEAL PTFE Packing System for Fisher A11, 8532, 8580, 8590, and Control-Disk Valves

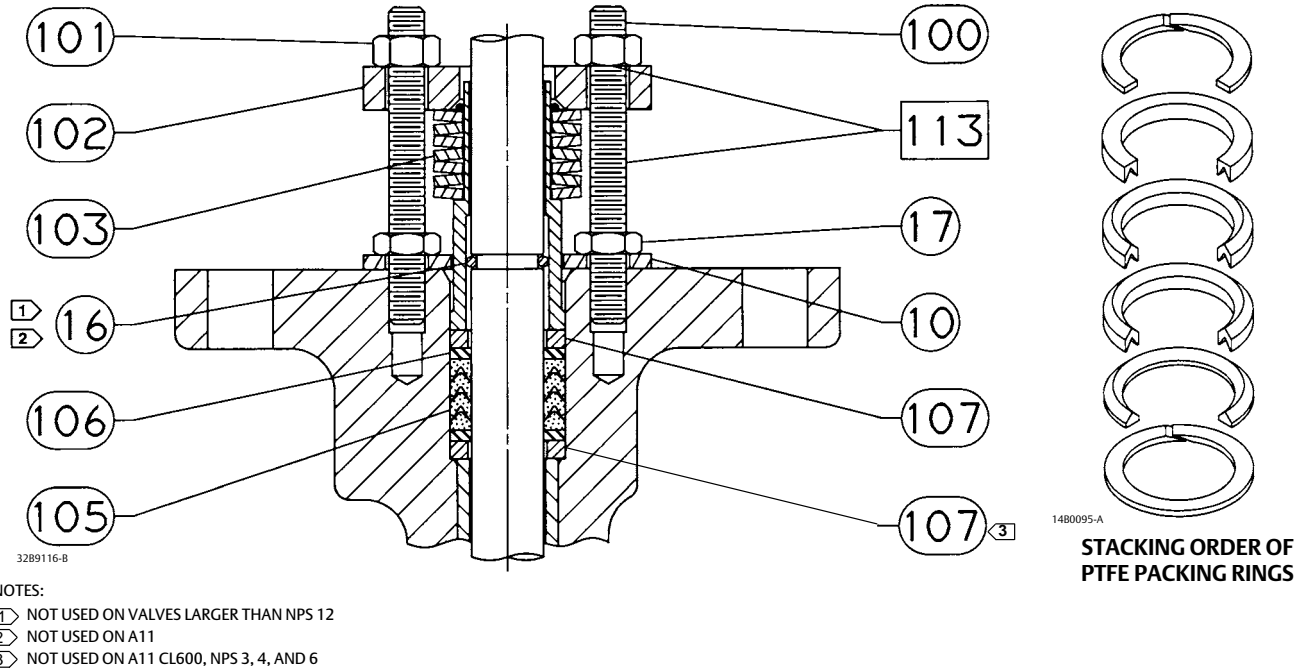

11. Install the packing flange (key 102) on the shaft, and install the packing nuts (key 101). Hand tighten them.

Note

In general, the following tightening procedure applies to all enhanced ENVIRO-SEAL packing systems—both sliding-stem and rotary.

NOTICE

Excessive force could cause valve body bushing displacement in Non-Series B Vee-Ball valves, allowing Vee-Ball misalignment, excessive seat leakage, or stalling of the actuator.

Note

Lubrication is required for the packing studs and nuts. Although it is important to properly lubricate the stud threads and internal nut threads, it is also important to properly lubricate the contacting face of the nut. See figures 2 through 5 and 7 for lubrication locations.

Figure 4. Typical Enhanced ENVIRO-SEAL Rotary Packing Arrangements with Graphite Packing for Fisher Vee-Ball, Eccentric Plug, and 8560 Valves

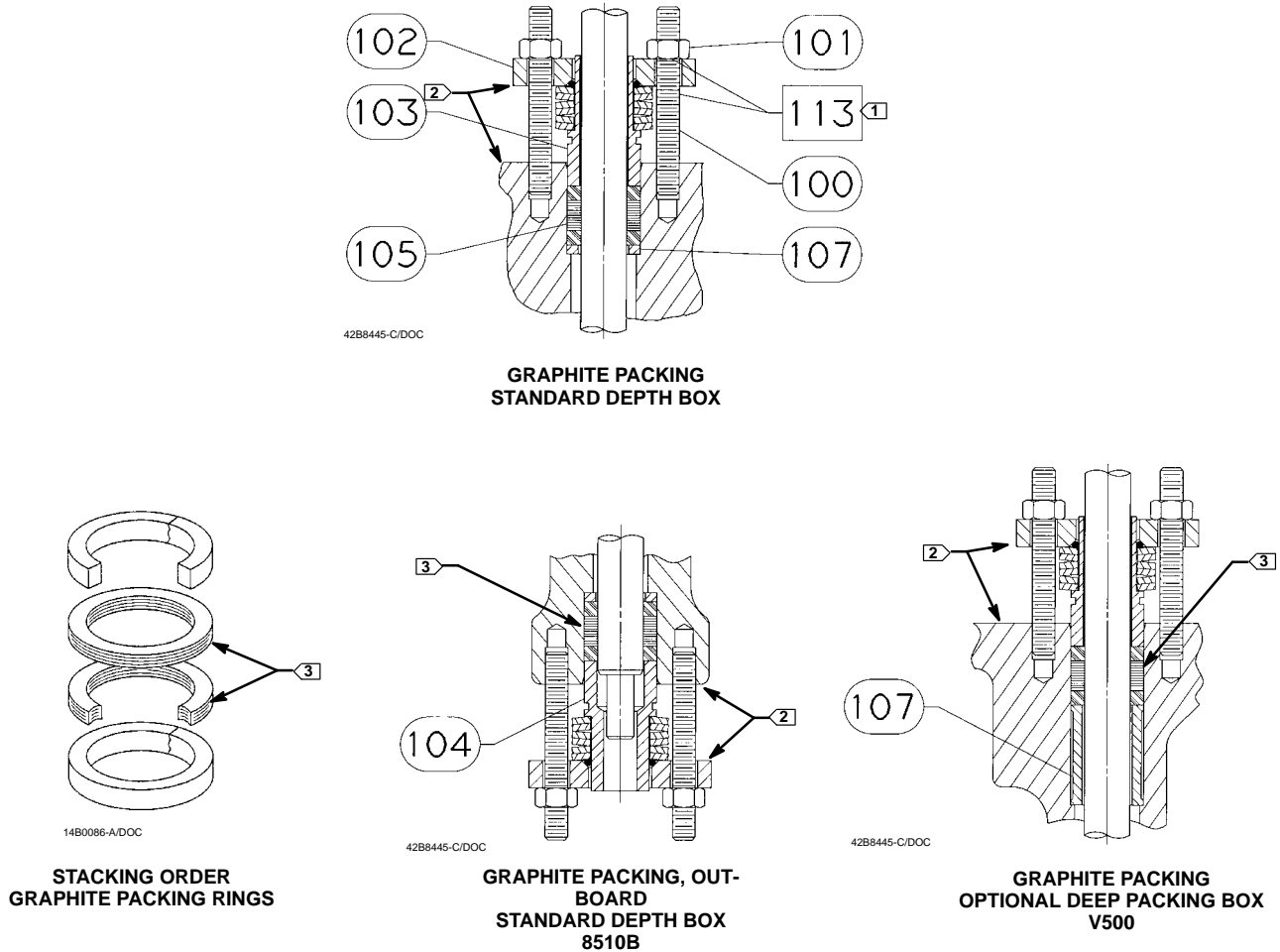

NOTES:

- 1 APPLY LUBRICANT
- 2 THESE TWO SURFACES MUST REMAIN PARALLEL AS YOU ALTERNATELY AND EVENLY TIGHTEN THE PACKING NUTS (KEY 101)
- 3 VALVE WITH SHAFTS LARGER THAN 38.1 mm (1-1/2 INCH) USE THREE GRAPHITE RINGS

Note the following definitions. You will need them for the next few steps. The **target load** is the point where the Belleville springs are designed for optimum performance, when they are compressed to 85% of their maximum deflection, or nearly flat. **Maximum deflection** is when the springs are 100% compressed, or completely flat.

12. You will obtain maximum benefit from your enhanced ENVIRO-SEAL packing system when you tighten the packing flange nuts and compress the Belleville springs to their “target load”.

To obtain the target load of 85% compression of maximum deflection, perform the following:

- Tighten the packing flange nuts alternately and evenly, keeping the packing flange parallel with the valve flange (see figure 7), until the Belleville springs are compressed 100% (or completely flat).

Figure 6. Belleville Spring Stacking Order (See Table 3)

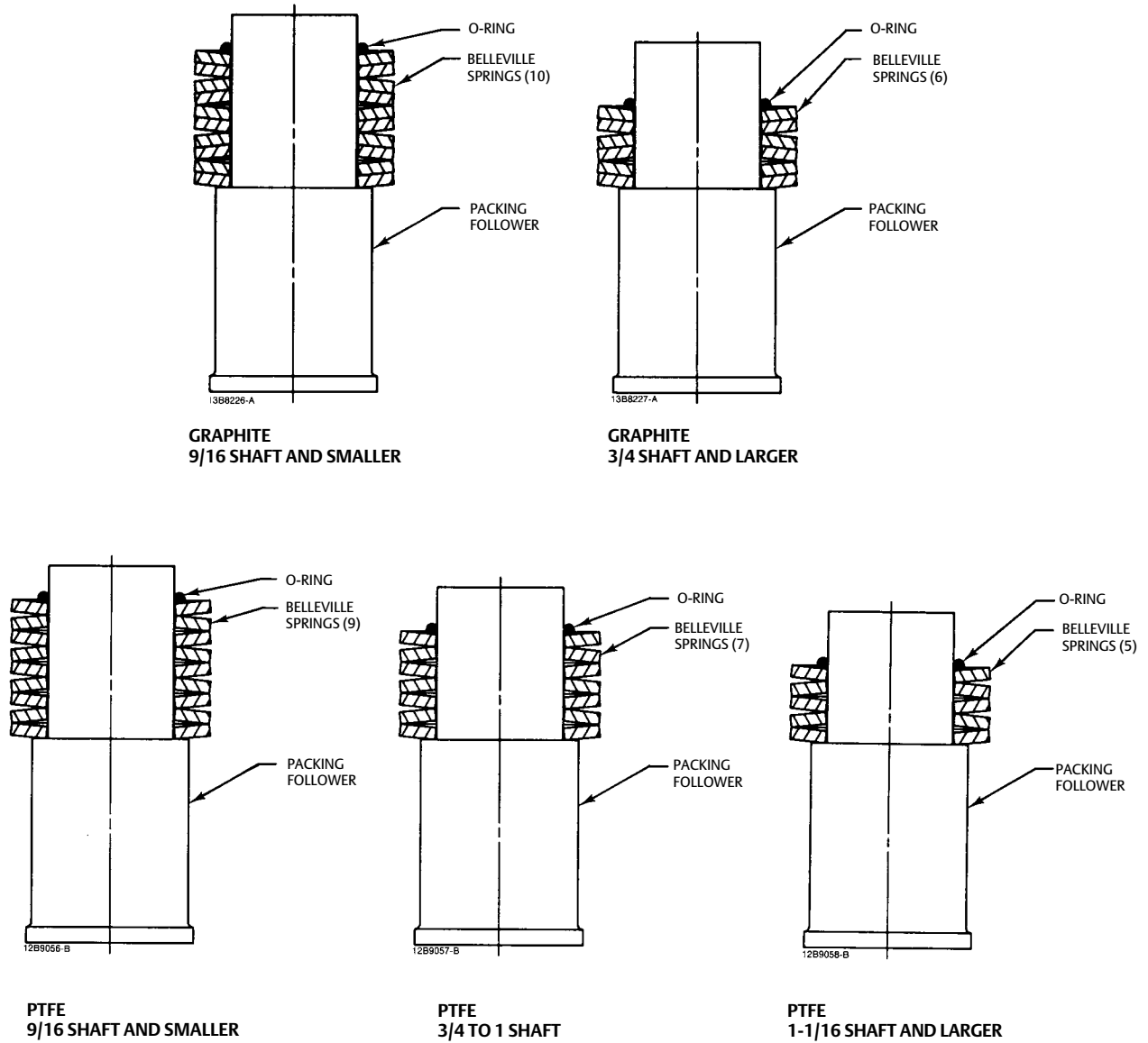

INCH

B2410-2

Figure 7. Enhanced ENVIRO-SEAL PTFE Packing System Detail

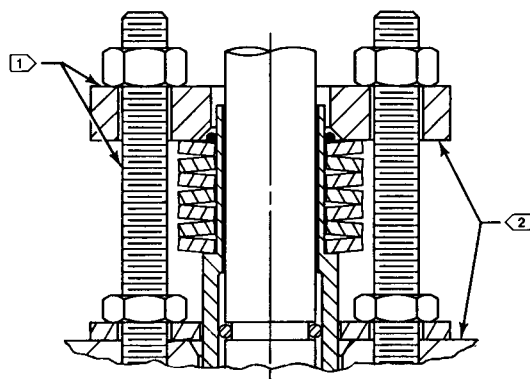

32B9116-B

NOTES:

- 1 > APPLY LUBRICANT
- 2 > THESE TWO SURFACES MUST REMAIN PARALLEL AS YOU ALTERNATELY AND EVENLY TIGHTEN THE PACKING NUTS.

Other Considerations

Note

The following check is only valid for rotary enhanced ENVIRO-SEAL packing systems and sliding-stem enhanced ENVIRO-SEAL or HIGH-SEAL packing systems.

When retrofitting an existing packing system or repacking a valve with enhanced ENVIRO-SEAL packing that has been in service, check the condition of the packing bore after you have removed the packing. An easy method for cleaning debris and minor imperfections from the bore is to use a brake cylinder hone attached to an electric drill. This method will do a good job of cleaning the packing bore without changing the dimension of the bore.

When you have completed this exercise, a good guideline to use in checking the condition of the packing bore is the 20/20 rule. If less than 20% of the surface area of the bore is pitted and if no pits are deeper than 0.010 inch, then your packing will work fine. This does not need to be an exact measurement; visual inspection is adequate. If the packing bore does not meet this criteria, however, you should replace the valve or have your Emerson service center repair it.

Table 3. Applicable Valve Sizes and Shaft Diameters⁽¹⁾

VALVE	VALVE SIZE, NPS	PRESSURE CLASS	VALVE SHAFT DIAMETER	
			mm	Inches
8510B	2	See 8560 bulletin (D102028X012)	12.7	1/2
	3		15.9	5/8
	4		19.1	3/4
	6		25.4	1
	8		31.8	1-1/4
	10		31.8	1-1/4
	12		38.1	1-1/2
8532	14	150	34.9	1-3/8
	16		38.1	1-1/2
	18		44.5	1-3/4
	20	300	50.8	2
	24		63.5	2-1/2
	24		88.9	3-1/2
8560	2	150	12.7	1/2
	3		12.7	1/2
	4		15.9	5/8
	6		19.1	3/4
	8		25.4	1
	10		31.8	1-1/4
	12		38.1	1-1/2
	2	300	12.7	1/2
	3		15.9	5/8
	4		19.1	3/4
	6		25.4	1
	8		31.8	1-1/4
	10		38.1	1-1/2
	12		44.5	1-3/4
V150	1	150	12.7	1/2
	1-1/2		15.9	5/8
	2		15.9	5/8
	3		19.1	3/4
	4		19.1	3/4
	6		25.4	1
	8		31.8	1-1/4
	10		31.8	1-1/4
	12		38.1	1-1/2
	14		44.5	1-3/4
	16		54	2-1/8
	20		63.5	2-1/2
	V200		1	150/300/ 600
1-1/2		15.9	5/8	
2		15.9	5/8	
3		19.1	3/4	
4		19.1	3/4	
6		25.4	1	
8		31.8	1-1/4	
10	31.8	1-1/4		
V300	1	300	12.7	1/2
	1-1/2		15.9	5/8
	2		15.9	5/8
	3		19.1	3/4
	4		19.1	3/4
	6		25.4	1
	8		31.8	1-1/4
	10		31.8	1-1/4
	12		38.1	1-1/2
	14		44.5	1-3/4
	16		54	2-1/8

Table 3. Applicable Valve Sizes and Shaft Diameters (cont.)

VALVE	VALVE SIZE, NPS	PRESSURE CLASS	VALVE SHAFT DIAMETER		
			mm	Inches	
CV500	3	150/300/ 600	25.4	1	
	4		31.8	1-1/4	
	6		38.1	1-1/2	
	8		38.1	1-1/2	
	10		44.5	1-3/4	
	12		53.8	2-1/8	
V500	1	150/300/ 600	12.7	1/2	
	1-1/2		15.9	5/8	
	2		15.9	5/8	
	3		25.4	1	
	4		31.8	1-1/4	
	6		31.8	1-1/2	
	8		38.1	1-1/2	
10	44.5	1-3/4			
A31A and A31D	3	150	14.3	9/16	
	4		17.5	11/16	
	6		23.8	15/16	
	8		23.8	15/16	
	10		28.5	1-1/8	
	12		31.8	1-1/4	
	14		34.9	1-3/8	
	16		38.1	1-1/2	
	18		44.5	1-3/4	
	20		50.8	2	
	24		63.5	2-1/2	
	3		300	14.3	9/16
	4	17.5		11/16	
	6	23.8		15/16	
	8	31.8		1-1/4	
	10	41.3		1-5/8	
	12	47.6		1-7/8	
	14	50.8		2	
	16	57.2		2-1/4	
	18	63.5		2-1/2	
	20	76.2		3	
	24	88.9		3-1/2	
	A41	2		150	12.7
		3	12.7		1/2
4		15.9	5/8		
6		19.1	3/4		
8		25.4	1		
10		31.8	1-1/4		
12		38.1	1-1/2		
2		300	12.7	1/2	
3			15.7	5/8	
4			19.0	3/4	
6			25.4	1	
8			31.8	1-1/4	
10	38.1		1-1/2		
12	44.4	1-3/4			
A11	3	600	14.3	9/16	
	4		19.1	3/4	
	6		28.5	1-1/8	
	8		38.1	1-1/2	
	10		44.5	1-3/4	
	12		57.2	2-1/4	
	14		63.5	2-1/2	
	16		76.2	3	
	18		88.9	3-1/2	

1. Shaft Diameter through the packing box.

Parts Ordering

Each valve assembly is assigned a serial number that can be found on the valve body. Refer to the serial number when contacting your [Emerson sales office](#) for technical assistance.

When ordering replacement parts, refer to the serial number and to the 11-character kit number for each kit required from the following list. Kits for valves with shaft sizes greater than 38.4 mm (1-1/2 inch) will not be available, however, ENVIRO-SEAL parts may be ordered separately. Consult your Emerson sales office for details.

⚠ WARNING

Use only genuine Fisher replacement parts. Components that are not supplied by Emerson should not, under any circumstances, be used in any Fisher valve, because they may void your warranty, might adversely affect the performance of the valve, and could cause personal injury and property damage.

Parts Kits

Retrofit Kits

Retrofit kits include all parts required for installation of the enhanced ENVIRO-SEAL packing system into existing rotary and high performance butterfly valves. Retrofit kits are available for single PTFE or graphite packing. See tables 5 through 7 for retrofit kit part numbers.

The 8510B has two packing boxes, one at the actuator end and one at the outboard end. Select a kit from each column of the following table.

Packing boxes in V500 and CV500 valve bodies may be deep drilled, (at one time standard on all CV500 and always available as an option). If the valve body being retrofitted has a deep packing box, use the longer packing box ring (key 107) from the original packing. Discard the 3 mm (1/8-inch) packing box ring from the retrofit kit. If a replacement packing box ring (long, key 107) is required, refer to the valve instruction manual for parts, or consult your Emerson sales office. Refer to figure 2, the view titled: Double PTFE Packing with Leakoff—Optional Deep Packing Box.

Note

1. Use the existing long packing box ring (key 107) that was furnished with the original valve when installing the retrofit kit in:
 - V200 NPS 8 and 10 valves, or
 - V150 and V300 NPS 8, 10, and 12 valves
-

Table 4. Retrofit Kit Included Parts

Key	Description	Quantity
10 ⁽⁵⁾	Anti-blowout follower ⁽⁵⁾	1
17 ⁽⁵⁾	Jam nut ⁽⁵⁾	1
100	Packing stud	2 ⁽⁶⁾ or 4 ⁽⁷⁾
101	Packing nut	2 ⁽⁶⁾ or 4 ⁽⁷⁾
102	Packing flange	1
103	Spring pack assembly ⁽¹⁾	1
104	Spring pack assembly ⁽²⁾	1
105	Packing Set	1
106	Anti-extrusion washer	2 ⁽³⁾
107	Packing box ring	2 ⁽⁴⁾
111	Tag	1
112	Cable	1

1. For use on Actuator end. The spring pack assembly is made up of the packing spring stack held in place by an O-ring on the packing follower.
 2. For use on Outboard end. The spring pack assembly is made up of the packing spring stack held in place by an O-ring on the packing follower.
 3. Not included in graphite packing kit.
 4. Only 1 req'd for NPS 18 CL300, NPS 20 CL150 and NPS 24 CL150. Two packing box rings required for 8560, 44.5 mm (1-3/4 inch) shaft. Not required on V150, V200 or V300 with 31.8 or 38.1 mm (1-1/4 or 1-1/2 inch) shafts.
 5. These are included in retrofit kits for 8532 and A11 valves.
 6. NPS 3 through 12 CL150 and NPS 3 through 8 CL300 for 8532; NPS 3 through 6 CL600, A11.
 7. NPS 14 through 24 CL150/300 for 8532; NPS 8 through 18 CL600, A11.

Table 5. Retrofit Kits for Fisher Vee-Ball, Eccentric Plug, 8560 and 8510B Valves with Spline Shafts

SHAFT DIAMETER, mm (INCH)	PTFE RETROFIT KITS PACKING BOX END		GRAPHITE RETROFIT KITS PACKING BOX END	
	Actuator End	Outboard End for 8510B Only	Actuator End	Outboard End for 8510B Only
12.7 (1/2)	RRTYXRT0012	RRTYXRT0082	RRTYXRT0312	RRTYXRT0382
15.9 (5/8)	RRTYXRT0022	RRTYXRT0092	RRTYXRT0322	RRTYXRT0392
19.1 (3/4)	RRTYXRT0032	RRTYXRT0102	RRTYXRT0332	RRTYXRT0402
25.4 (1)	RRTYXRT0052	RRTYXRT0112	RRTYXRT0352	RRTYXRT0412
31.8 (1-1/4)	RRTYXRT0062	RRTYXRT0122	RRTYXRT0362	RRTYXRT0422
38.1 (1-1/2)	RRTYXRT0072	RRTYXRT0132	RRTYXRT0372	RRTYXRT0432
8560 NPS 10 (CL 300)	RRTYXRT0672	---	RRTYXRT0812	---
8560 NPS 12 (CL 150)	RRTYXRT0672	---	RRTYXRT0812	---
44.5 (1-3/4)	RRTYXRT0682	RRTYXRT0762	RRTYXRT0822	RRTYXRT0902
8560 NPS 12 (CL 300)	RRTYXRT0692	---	RRTYXRT0832	---
V500 NPS 10	RRTYXRT0702	---	RRTYXRT0842	---
54 (2-1/8)	RRTYXRT0722	---	RRTYXRT0862	---
63.5 (2-1/2)	RRTYXRT0732	RRTYXRT0782	RRTYXRT0872	RRTYXRT0922

Table 6. Retrofit Kits for Fisher Vee-Ball, Eccentric Plug, 8510B and A41 valves with Double D and Keyed End Connection

SHAFT DIAMETER, mm (INCH)	PTFE RETROFIT KITS PACKING BOX END		GRAPHITE RETROFIT KITS PACKING BOX END	
	Actuator End	Outboard End for 8510B Only	Actuator End	Outboard End for 8510B Only
Double D				
12.7 (1/2)	RRTYXRT0972	RRTYXRT0082	RRTYXRT1072	RRTYXRT0382
15.9 (5/8)	RRTYXRT0982	RRTYXRT0092	RRTYXRT1082	RRTYXRT0392
19.1 (3/4)	RRTYXRT0992	RRTYXRT0102	RRTYXRT1092	RRTYXRT0402
25.4 (1)	RRTYXRT1012	RRTYXRT0112	RRTYXRT1102	RRTYXRT0412
31.8 (1-1/4)	RRTYXRT1022	RRTYXRT0122	RRTYXRT1112	RRTYXRT0422
38.1 (1-1/2)	RRTYXRT1032	RRTYXRT0132	RRTYXRT1122	RRTYXRT0432
44.5 (1-3/4)	RRTYXRT1042	RRTYXRT0762	RRTYXRT1132	RRTYXRT0902
Keyed				
54 (2-1/8)	RRTYXRT1052	---	RRTYXRT1142	---
63.5 (2-1/2)	RRTYXRT1062	RRTYXRT0782	RRTYXRT1152	RRTYXRT0922

Table 7. Retrofit Kit Part Numbers for Fisher 8532 and A11 Butterfly Valves

8532				
Valve Size, NPS	Pressure Class	Shaft Diameter ⁽¹⁾⁽²⁾ , mm (Inch)	Retrofit Kits	
			PTFE	Graphite
3	150, 300	14.3 (9/16)	RRTYXRT0202	RRTYXRT0502
4	150, 300	17.5 (11/16)	RRTYXRT0212	RRTYXRT0512
6	150, 300	23.8 (15/16)	RRTYXRT0222	RRTYXRT0522
8	150	23.8 (15/16)	RRTYXRT0232	RRTYXRT0532
	300	31.8 (1-1/4)	RRTYXRT0242	RRTYXRT0542
10	150	28.5 (1-1/8)	RRTYXRT0252	RRTYXRT0552
	300	41.3 (1-5/8)	RRTYXRT0572	---
12	150	31.8 (1-1/4)	RRTYXRT0262	RRTYXRT0562
	300	47.6 (1-7/8)	RRTYXRT0582	---
14	150	34.9 (1-3/8)	RRTYXRT0592	
	300	50.8 (2)	RRTYXRT0602	
16	150	38.1 (1-1/2)	RRTYXRT0612	
	300	57.2 (2-1/4)	RRTYXRT0622	
18	150	44.5 (1-3/4)	RRTYXRT0632	
	300	63.5 (2-1/2)	RRTYXRT0642	
20	150	50.8 (2)	RRTYXRT0652	
24	150	63.5 (2-1/2)	RRTYXRT0662	
A11				
Valve Size, NPS	Pressure Class	Shaft Diameter	PTFE Retrofit Kits	Graphite Retrofit Kits
3	600	14.3 (9/16)	12B4122X012	12B4125X012
4		19.1 (3/4)	14B3988X012	14B3989X012
6		28.6 (1-1/8)	12B4105X012	12B4107X012
8		38.1 (1-1/2)	13B9289X012	14B3985X012
10		44.5 (1-3/4)	13B9285X012	13B9286X012
12		57.2 (2-1/4)	14B1323X012	14B3978X012
14		63.5 (2-1/2)	12B4111X012	12B4116X012
16		76.2 (3)	14B5651X022	14B5660X022
18		88.9 (3-1/2)	14B5729X042	14B5736X042
1. Shaft diameter: Diameter through the packing box. 2. For larger shaft sizes, consult your Emerson sales office .				

Repair Kits

PTFE repair kits include one packing set and two anti-extrusion washers. Graphite packing sets include two packing rings and two anti-extrusion rings. See table 8.

The 8510B has two packing boxes, one at the actuator end and one at the outboard end. A quantity of two of the appropriate kit is required to repair both ends.

⚠ WARNING

Use only genuine Fisher replacement parts. Components that are not supplied by Emerson should not, under any circumstances, be used in any Fisher valve, because they may void your warranty, might adversely affect the performance of the valve, and could cause personal injury and property damage.

Table 8. Repair Kits for Fisher Vee-Ball, Eccentric Plug, and 8560 Valves

Shaft Diameter mm (Inch)	PTFE Kits	Graphite Packing Set
12.7 (1/2)	RRTYX000012	13B8816X012
15.9 (5/8)	RRTYX000022	13B8816X032
19.1 (3/4)	RRTYX000032	13B8816X052
25.4 (1)	RRTYX000052	13B8816X092
31.8 (1-1/4)	RRTYX000062	13B8816X112
38.1 (1-1/2)	RRTYX000072	13B8816X142
44.5 (1-3/4)	RRTYX000232	13B8816X152
54.0 (2-1/8)	RRTYX000252	13B8816X182
63.5 (2-1/2)	RRTYX000262	13B8816X162

Table 9. Repair Kit Part Numbers for Fisher 8532 and A11 Butterfly Valves

8532						
Valve Size, NPS	Pressure Class	Shaft Diameter ⁽¹⁾⁽²⁾ , mm (Inch)	Repair Kits			
			PTFE	Graphite Packing Set		
3	150, 300	14.3 (9/16)	RRTYX000112		13B8816X022	
4	150, 300	17.5 (11/16)	RRTYX000122		13B8816X042	
6	150, 300	23.8 (15/16)	RRTYX000132		13B8816X082	
8	150	23.8 (15/16)	RRTYX000132		13B8816X082	
	300	31.8 (1-1/4)	RRTYX000142		13B8816X122	
10	150	28.5 (1-1/8)	RRTYX000092		13B8816X102	
	300	41.3 (1-5/8)	RRTYX000152		---	
12	150	31.8 (1-1/4)	RRTYX000142		13B8816X122	
	300	47.6 (1-7/8)	RRTYX000162			
14	150	34.9 (1-3/8)	RRTYX000172			
	300	50.8 (2)	RRTYX000182			
16	150	38.1 (1-1/2)	RRTYX000192			
	300	57.2 (2-1/4)	RRTYX000202		---	
18	150	44.5 (1-3/4)	RRTYX000212			
	300	63.5 (2-1/2)	RRTYX000222			
20	150	50.8 (2)	RRTYX000182			
24	150	63.5 (2-1/2)	RRTYX000222			
A11						
Valve Size, NPS	Pressure Class	Shaft Diameter	PTFE Packing Kits	Anti-Extrusion Ring ⁽³⁾	Graphite Packing Kits	Packing Box Ring
3	600	14.3 (9/16)	12B9122X012	12B9121X012	13B8816X022	12B9118X012
4		19.1 (3/4)	12B7414X012	12B7418X012	13B8816X052	16A6084X012
6		28.6 (1-1/8)	12B9078X012	12B9084X012	13B8816X102	12B9077X012
8		38.1 (1-1/2)	12B7462X012	12B7466X012	13B8816X142	16A6087X012
10		44.5 (1-3/4)	13B9155X012	13B9159X012	14B3541X032	13B9160X012
12		57.2 (2-1/4)	14B3647X012	14B3642X012	14B3541X052	13B2187X012
14		63.5 (2-1/2)	12B7782X012	12B7783X012	14B3541X042	13B8709X012
16		76.2 (3)	14B5652X012	14B5656X012	14B3541X062	18A4189X012
18		88.9 (3-1/2)	14B5730X012	14B5734X012	14B3541X072	14B5735X012
1. Shaft diameter: Diameter through the packing box. 2. For larger shaft sizes, consult your Emerson sales office . 3. The A11 requires 2 Anti-Extrusion Rings.						

A coupler is required for the following valve/actuator combinations when retrofitting an existing A31A or A31D with an ENVIRO-SEAL packing system.

Table 10. Coupler Part Number for Fisher A31A or A31D Valves with Selected Actuators

SHAFT DIAMETER, mm (INCH)	Valve Size	Actuator Type	Coupler Part No.
14.3 (9/16)	NPS 3 CL150/300 NPS 3 CL150/300 NPS 3 CL150/300	Fisher 1032 XL70 thru XL280 Fisher 1032 XL425 thru XL680 D and S Series (Elomatic) SR15	13B1596X012 13B1907X012 13B1595X012
17.5 (11/16)	NPS 4 CL150/300 NPS 4 CL150/300 NPS 4 CL150/300 NPS 4 CL150/300	Fisher 1032 XL185 thru XL280 Fisher 1032 XL425 thru XL680 Bettis HD 521, 721, 722 D and S Series (Elomatic) S20	13B1600X012 13B1908X012 13B1597X012 13B1599X012
23.8 (15/16)	NPS 6 CL150/300, NPS 8 CL150 NPS 6 CL150/300, NPS 8 CL150 NPS 6 CL150/300, NPS 8 CL150 NPS 6 CL150/300, NPS 8 CL150 NPS 6 CL150/300, NPS 8 CL150 NPS 6 CL150/300, NPS 8 CL150 NPS 6 CL150/300, NPS 8 CL150 NPS 6 CL150/300, NPS 8 CL150 NPS 6 CL150/300, NPS 8 CL150 NPS 6 CL150/300, NPS 8 CL150 NPS 6 CL150/300, NPS 8 CL150 NPS 6 CL150/300, NPS 8 CL150 NPS 6 CL150/300, NPS 8 CL150 NPS 6 CL150/300, NPS 8 CL150 NPS 6 CL150/300, NPS 8 CL150	Fisher 1031 Size 26 Fisher 1031 Size 33 Fisher 1032 XL680-XL1370 5M Gear Bettis CB 315 Bettis CB 415 Bettis CB 420 Bettis CB 520 Bettis CB 525 Bettis CB 725 Bettis HD 251.5 Bettis HD 521, 721, 722 Fire Sentry Limitorque T-100	13B1610X012 13B1611X012 13B1613X012 13B1601X012 13B1602X012 13B1905X012 13B1605X012 13B1906X012 13B1604X012 13B1606X012 13B1609X012 13B1603X012 13B1608X012 13B1607X012
28.5 (1-1/8)	NPS 10 CL150 NPS 10 CL150 NPS 10 CL150 NPS 10 CL150 NPS 10 CL150 NPS 10 CL150 NPS 10 CL150 NPS 10 CL150	Fisher 1031 Size 26 Fisher 1031 Size 33 Fisher 1032 XL680-XL1370 Bettis CB 525 Bettis CB 725 Bettis HD 521, 721, 722 Fire Sentry Limitorque T-100	13B1620X012 13B1621X012 13B1624X012 13B1614X012 13B1617X012 13B1615X012 13B1619X012 13B1618X012
31.8 (1-1/4)	NPS 8 CL300, NPS 12 CL150 NPS 8 CL300, NPS 12 CL150 NPS 8 CL300, NPS 12 CL150 NPS 8 CL300, NPS 12 CL150 NPS 8 CL300, NPS 12 CL150 NPS 8 CL300, NPS 12 CL150 NPS 8 CL300, NPS 12 CL150 NPS 8 CL300, NPS 12 CL150 NPS 8 CL300, NPS 12 CL150 NPS 8 CL300, NPS 12 CL150 NPS 8 CL300, NPS 12 CL150 NPS 8 CL300, NPS 12 CL150 NPS 8 CL300, NPS 12 CL150 NPS 8 CL300, NPS 12 CL150	Fisher 1031 Size 26 Fisher 1031 Size 33 Fisher 1032 XL680 - XL1370 Bettis CB 525 Bettis CB 725 Bettis HD 521, 721, 722 150 Bettis HD 731, 732 D and S Series (Elomatic) SR110 Limitorque SMB-000-5-HOBC Limitorque T-250 Rotork 250	13B1081X012 13B1082X012 13B1086X012 13B1073X012 13B1077X012 13B1074X012 13B1075X012 13B1075X012 13B1076X012 13B1084X012 13B1246X012 13B1079X012

The existing couplers, listed below, can accommodate a retrofit with an ENVIRO-SEAL packing system. Coupler replacement is not required when retrofitting the valve/actuator combinations listed below. For information about couplers for the A11 CL600 valves, contact your [Emerson sales office](#).

Table 11. Coupler Part Number for Fisher A31A or A31D Valves with Selected Actuators

SHAFT DIAMETER, mm (INCH)	Valve Size	Actuator Type	Coupler Part No.
14.3 (9/16)	NPS 3 CL150/300 NPS 3 CL150/300 NPS 3 CL150/300 NPS 3 CL150/300	Bettis CB 315 Bettis CB 415 Bettis CB 420 Bettis CB 520	V160124X012 V160125X012 V151828X012 V154549X012
17.5 (11/16)	NPS 4 CL150/300 NPS 4 CL150/300 NPS 4 CL150/300 NPS 4 CL150/300	Bettis CB 315 Bettis CB 415 Bettis CB 420 Bettis CB 520	V160108X012 V160107X012 V151731X012 V154600X012
28.5 (1-1/8)	NPS 10 CL150 NPS 10 CL150	Bettis CB 420 Bettis CB 520	V160209X012 V160212X012
31.8 (1-1/4)	NPS 8 CL300, NPS 12 CL150 NPS 8 CL300, NPS 12 CL150	Bettis CB 420 Bettis CB 520	V160208X012 V160213X012

Neither Emerson, nor any of their affiliated entities assumes responsibility for the selection, use or maintenance of any product. Responsibility for proper selection, use, and maintenance of any product remains solely with the purchaser and end user.

Fisher, ENVIRO-SEAL, and Vee-Ball are marks owned by one of the companies in the Emerson business division of Emerson Electric Co. Emerson, and the Emerson logo are trademarks and service marks of Emerson Electric Co. All other marks are the property of their respective owners.

The contents of this publication are presented for informational purposes only, and while every effort has been made to ensure their accuracy, they are not to be construed as warranties or guarantees, express or implied, regarding the products or services described herein or their use or applicability. All sales are governed by our terms and conditions, which are available upon request. We reserve the right to modify or improve the designs or specifications of such products at any time without notice.

Emerson

Marshalltown, Iowa 50158 USA

Sorocaba, 18087 Brazil

Cernay 68700 France

Dubai, United Arab Emirates

Singapore 128461 Singapore

www.Fisher.com

