

## Introduction

This installation guide provides instructions for installation, startup and adjustment. To receive a copy of the instruction manual, contact your local Sales Office or view a copy at [www.fisherregulators.com](http://www.fisherregulators.com). For further information refer to: Type LR125 Instruction Manual, D103576X012.

## P.E.D. Categories

This product may be used as a safety accessory with pressure equipment in the following Pressure Equipment Directive 97/23/EC categories.

PRODUCT SIZE	CATEGORY	FLUID TYPE
DN 25 and 50 / 1 and 2 in.	SEP	Liquid
DN 80 and 100 / 3 and 4 in.	II	Liquid

## Specifications

### Main Valve Body Sizes, End Connection Styles and Structural Design Ratings<sup>(1)</sup>

See Table 1

### Outlet (Control) Pressure Ranges

See Table 3

### Main Valve Minimum Differential Pressure<sup>(1)</sup>

See Table 6

### Maximum Inlet Pressure<sup>(1)</sup>

**Type LR125 Main Valve:** See Table 1

**Type MR95H/MR95HP Pilot:** See Table 2

**Type 112 Restrictor:** 103 bar / 1500 psig

### Temperature Capabilities<sup>(1)</sup>

See Table 4

### Main Valve Internal Inlet Strainer Sizes

**DN 25 / 1 in.:**

12 Mesh (1.68 mm / 0.0661 in.)<sup>(2)</sup>

**DN 50, 80 and 100 / 2, 3 and 4 in.:**

10 Mesh (2 mm / 0.0787 in.)<sup>(2)</sup>

## Installation



### WARNING

Only qualified personnel shall install or service a regulator. Regulators should be installed, operated and maintained in accordance with international and applicable codes and regulations and Fisher® instructions.

If the regulator vents fluid or a leak develops in the system, it indicates that service is required. Failure to take the regulator out of service immediately may create a hazardous condition.

Personal injury, equipment damage or leakage due to escaping fluid or bursting of pressure containing parts may result if this regulator is overpressured or is installed where service conditions could exceed the limits given in the Specifications section or where conditions exceed any ratings of the adjacent piping or piping connections.

To avoid such injury or damage, provide pressure-relieving or pressure-limiting devices (as required by the appropriate code, regulation or standard) to prevent service conditions from exceeding limits.

Additionally, physical damage to the regulator could result in personal injury and property damage due to escaping fluid. To avoid such injury and damage, install the regulator in a safe location.

Clean out all pipelines before installation of the regulator and check to be sure the regulator has not been damaged or has collected foreign material during shipping. For NPT bodies, apply pipe compound to the external pipe threads. For flanged bodies, use suitable line gaskets and approved piping and bolting practices. Install the regulator in any position desired, unless otherwise specified, but be sure flow through the body is in the direction indicated by the arrow on the body.

### Note

It is important that the regulator be installed so that the vent hole in the spring case is unobstructed at all times. For outdoor installations, the regulator should be located away from vehicular traffic and positioned so that water, ice and other foreign materials cannot enter the spring case through the vent. Avoid placing the regulator beneath eaves or downspouts and be sure it is above the probable snow level.

1. The pressure/temperature limits in this Installation Guide and any applicable standard or code limitation should not be exceeded.  
2. Nominal sieve opening.

# Type LR125

**Table 1. Type LR125 Main Valve Body Sizes, End Connection Styles, Structural Design Ratings and Maximum Operating Inlet Pressure<sup>(1)</sup>**

MAIN VALVE BODY SIZE		MAIN VALVE BODY MATERIAL	END CONNECTION STYLES <sup>(2)</sup>	STRUCTURAL DESIGN RATING <sup>(3)</sup>		MAXIMUM OPERATING INLET PRESSURE <sup>(3)</sup>	
DN	In.			bar	psig	bar	psig
25, 50, 80 and 100	1, 2, 3 and 4	WCC Steel	NPT or SWE (1 and 2 in. only)	103	1500	41.4	600
			CL150 RF	20.0	290	20.0	290
			CL300 RF	51.7	750	41.4	600
			CL600 RF	103	1500		
			PN 16/25/40 RF <sup>(4)</sup>	40.0	580		
		CF8M Stainless steel	NPT (1 and 2 in. only)	99.2	1440	37.9	550
			CL150 RF	19.0	275	19.0	275
			CL300 RF	49.6	720	37.9	550
			CL600 RF	99.2	1440		
			PN 16/25/40 RF <sup>(4)</sup>	40.0	580		

1. The pressure/temperature limits in this Installation Guide and any applicable standard or code limitation should not be exceeded.
2. Ratings and end connections for other than ASME standard can usually be provided. Contact your local Sales Office for assistance.
3. Maximum cold working pressure (CWP) per ASME B16.34 or product bulletin limit, whichever is lowest. Temperature may decrease these maximum pressure.
4. Not available for DN 100 / 4 in. body size.

**Table 2. Pilot Maximum Operating Pressure<sup>(1)(2)</sup>**

PILOT	BODY SIZE	BODY AND SPRING CASE MATERIAL	MAXIMUM INLET PRESSURE	MAXIMUM OUTLET PRESSURE
Type MR95H	1/2 NPT	Steel Stainless steel	20.7 bar / 300 psig 20.7 bar / 300 psig	20.7 bar / 300 psig 20.7 bar / 300 psig
Type MR95HP	1/2 NPT	Steel Stainless steel	41.4 bar / 600 psig 41.4 bar / 600 psig	41.4 bar / 600 psig 37.9 bar / 550 psig

1. The pressure/temperature limits in this Installation Guide, and any applicable standard or code limitation should not be exceeded.
2. Temperature and/or the body end connection may decrease these maximum pressures.

**Table 3. Outlet (Control) Pressure Ranges**

PILOT	OUTLET PRESSURE RANGE		SPRING WIRE DIAMETER		SPRING FREE LENGTH		SPRING PART NUMBER AND COLOR
	bar	psig	mm	In.	mm	In.	
Type MR95H	1.0 to 2.1	15 to 30	5.26	0.207	63.5	2.50	ERCA04288A0, Yellow ERAA01910A0, Green ERAA01911A0, Red
	1.7 to 5.2	25 to 75	5.94	0.234	65.9	2.60	
	4.8 to 10.3	70 to 150	7.19	0.283	62.0	2.44	
Type MR95HP	1.0 to 6.9	15 to 100	7.14	0.281	63.5	2.50	ERCA04294A0, Unpainted ERCA04293A0, Unpainted
	5.5 to 27.6	80 to 400	9.53	0.375	63.5	2.60	

**Table 4. Diaphragm Material Selection Information**

CRITERIA	DIAPHRAGM MATERIAL		
	17E68 Nitrile (NBR) (standard)	17E97 Nitrile (NBR)	17E88 Fluorocarbon (FKM)
Liquid Temperature	-29 to 66°C / -20 to 150°F	-18 to 66°C / 0 to 150°F	-18 to 121°C / 0 to 250°F <sup>(1)(2)</sup>
General Applications	Best for low pressure differential service or cold temperature applications	Best for abrasive or erosive service applications	Best for high temperature applications
Heavy Particle Erosion	Fair	Excellent	Good

1. Fluorocarbon (FKM) is limited to 93°C / 200°F in hot water.
2. For differential pressures above 28 bar / 400 psig diaphragm temperature is limited to 66°C / 150°F.

**Table 5. Main Valve Maximum Pressure Ratings, Diaphragm Selection Information and Main Spring Selection<sup>(1)</sup>**

BODY SIZE		DIAPHRAGM MATERIAL	MAXIMUM OPERATING INLET PRESSURE <sup>(4)</sup>		MAXIMUM OPERATING DIFFERENTIAL PRESSURE <sup>(3)(4)</sup>		MAXIMUM EMERGENCY INLET AND DIFFERENTIAL PRESSURE		MAIN SPRING COLOR
DN	NPS		bar	psig	bar	psig	bar d	psid	
25	1	17E68 Nitrile (NBR)	20.7	300	20.7	300	20.7	300	Black and Yellow
		17E97 Nitrile (NBR)	20.7	300	20.7	300	20.7	300	Black and Yellow
		17E97 Nitrile (NBR)	41.4	600	41.4	600	41.4	600	Black and White <sup>(2)</sup>
		17E88 Fluorocarbon (FKM)	20.7	300	20.7	300	20.7	300	Black and Yellow
		17E88 Fluorocarbon (FKM)	41.4	600	34	500	41.4	600	Black and White <sup>(2)</sup>
50	2	17E68 Nitrile (NBR)	20.7	300	20.7	300	20.7	300	Green and White
		17E97 Nitrile (NBR)	20.7	300	20.7	300	20.7	300	Green and White
		17E97 Nitrile (NBR)	41.4	600	41.4	600	41.4	600	Purple <sup>(2)</sup>
		17E88 Fluorocarbon (FKM)	20.7	300	20.7	300	20.7	300	Green and White
		17E88 Fluorocarbon (FKM)	41.4	600	34	500	41.4	600	Purple <sup>(2)</sup>
80	3	17E68 Nitrile (NBR)	20.7	300	20.7	300	20.7	300	Light Blue and White
		17E97 Nitrile (NBR)	20.7	300	20.7	300	20.7	300	Light Blue and White
		17E97 Nitrile (NBR)	41.4	600	41.4	600	41.4	600	Black <sup>(2)</sup>
		17E88 Fluorocarbon (FKM)	20.7	300	20.7	300	20.7	300	Light Blue and White
		17E88 Fluorocarbon (FKM)	41.4	600	34	500	41.4	600	Black <sup>(2)</sup>
100	4	17E68 Nitrile (NBR)	20.7	300	20.7	300	20.7	300	Green and White
		17E97 Nitrile (NBR)	20.7	300	20.7	300	20.7	300	Green and White
		17E97 Nitrile (NBR)	41.4	600	41.4	600	41.4	600	Red <sup>(2)</sup>
		17E88 Fluorocarbon (FKM)	20.7	300	20.7	300	20.7	300	Green and White
		17E88 Fluorocarbon (FKM)	41.4	600	34	500	41.4	600	Red <sup>(2)</sup>

1. See Table 1 for main valve structural design ratings and Table 2 for pilot ratings.  
 2. The black and white, purple, black and red springs are only recommended for applications where the maximum inlet pressure can exceed 20.7 bar / 300 psig.  
 3. Maximum differential pressures may be lower for applications where cavitation may be present.  
 4. These are recommendations that provide the best regulator performance for a typical application. Please contact your local Sales Office for further information if a deviation from the standard recommendations are required.

**Table 6. Main Valve Minimum Differential Pressure<sup>(1)</sup>**

MAIN VALVE BODY SIZE		MAIN SPRING PART NUMBER AND COLOR	DIAPHRAGM MATERIAL	MINIMUM DIFFERENTIAL, PERCENT OF CAPACITY			
DN	In.			For 90% Capacity		For 100% Capacity	
				bar d	psid	bar d	psid
25	1	GE12727X022, Black and Yellow	17E68 and 17E88	2.1	30	2.1	30
		19B2401X022, Black and White	17E97	2.5	35	2.5	35
			17E88 and 17E97	3.0	43	3.0	43
50	2	18B2126X022, Green and White	17E68 and 17E88	1.2	18	1.3	19
			17E97	1.7	24	1.7	24
		18B5955X012, Red	17E88 and 17E97	2.0	29	2.1	31
80	3	19B0781X022, Light Blue and White	17E68 and 17E88	1.5	21	1.9	28
			17E97	1.6	23	1.6	23
		19B0782X022, Black and White	17E88 and 17E97	2.2	32	2.6	38
100	4	18B8501X022, Green and White	17E68 and 17E88	1.1	16	2.1	30
			17E97	1.1	16	2.3	34
		18B8502X022, Red and White	17E88 and 17E97	1.5	21	2.8	40

1. See Table 1 for Type LR125 main valve structural design ratings and Table 2 for pilot rating.

## Overpressure Protection

The recommended pressure limitations are stamped on the regulator nameplate. Some type of overpressure protection is needed if the actual inlet pressure exceeds the maximum operating outlet pressure rating. Overpressure protection should also be provided if the regulator inlet pressure is greater than the safe working pressure of the downstream equipment.

Regulator operation below the maximum pressure limitations does not preclude the possibility of damage from external sources or debris in the line. The regulator should be inspected for damage after any overpressure condition.

## Startup

The regulator is factory set at approximately the midpoint of the spring range or the pressure requested, so an initial adjustment may be required to give the desired results. With proper installation

completed and relief valves properly adjusted, slowly open the upstream and downstream shutoff valves.

## Adjustment

To change the outlet pressure, loosen the jam nut and turn the adjusting screw clockwise to increase outlet pressure or counterclockwise to decrease it. Monitor the outlet pressure with a test gauge during the adjustment. Tighten the jam nut to maintain the desired setting.

## Taking Out of Service (Shutdown)



**To avoid personal injury resulting from sudden release of pressure, isolate the regulator from all pressure before attempting disassembly.**

# Type LR125

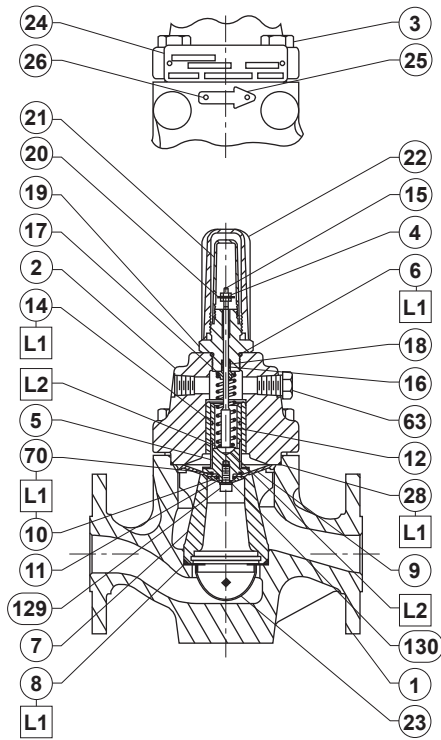

49B6019\_A

DN 25 / 1 IN. BODY SIZE

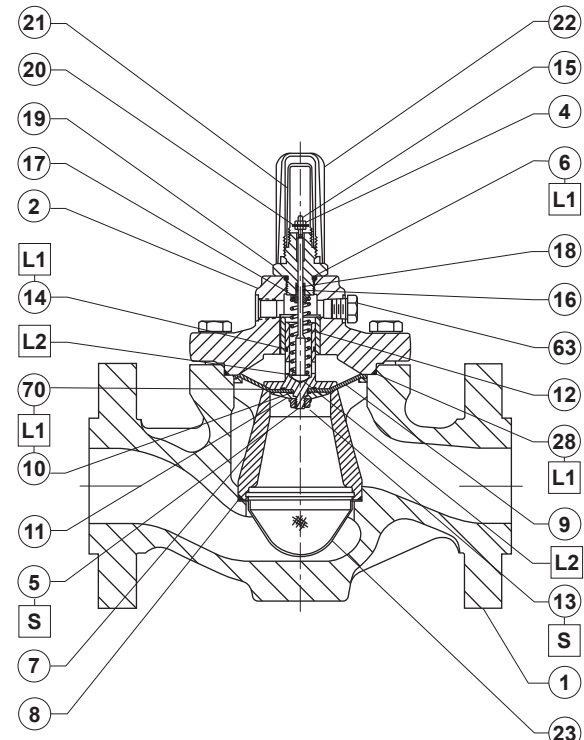

48B2142\_C

DN 50, 80 AND 100 / 2, 3 AND 4 IN. BODY SIZES

- APPLY LUBRICANT / SEALANT<sup>(1)</sup>:  
 L1 = LITHIUM POLYMER TYPE LUBRICANT (MULTI-PURPOSE GREASE)  
 L2 = ANTI-SEIZE LUBRICANT  
 S = MEDIUM STRENGTH THREADLOCKER

1. Lubricants and sealant must be selected such that they meet the temperature requirements.

Figure 1. Type LR125 Main Valve

## Parts List

### Type LR125 Main Valve

Key	Description
1	Valve Body
2	Bonnet Assembly
3	Cap Screw
4	Hex Nut
5	Top Plug
6*	O-ring
7	Cage
8*	Cage O-ring
9*	Diaphragm
10*	O-ring
11	Bottom Plug
12	Main Valve Spring
13	Flanged Hex Nut
14*	Top Plug O-ring
15	Stem
16*	Back-up Ring

Key	Description
17	Upper Spring Seat
18*	O-ring
19	Indicator Fitting or Travel Indicator Plug
20	Indicator Washer
21	Indicator Cover
22	Indicator Protector
23	Inlet Strainer
24	Nameplate
25	Flow Arrow
26	Drive Screw
28*	O-ring
63	Pipe Plug
70*	O-ring
129	Socket Head Screw
130	Lock Washer

\*Recommended spare part

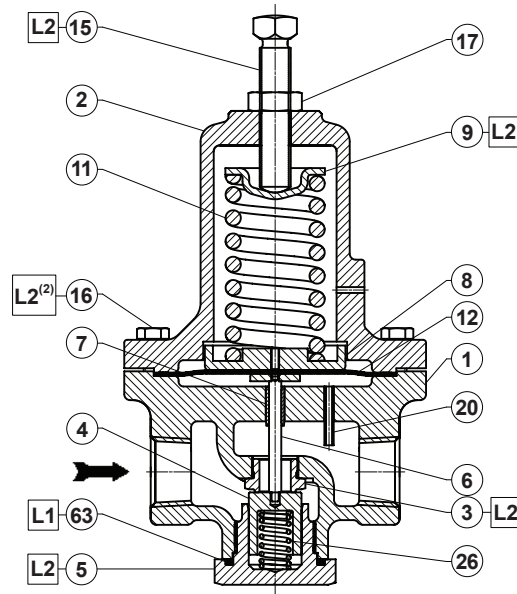

GF04914

□ APPLY LUBRICANT / SEALANT<sup>(1)</sup>:

L1 = GENERAL PURPOSE PTFE OR LITHIUM GREASE

L2 = ANTI-SEIZE COMPOUND

1. Lubricant and sealant must be selected such that they meet the temperature requirements.

2. Apply L2 (anti-seize compound) on key 16 for Stainless steel bolts.

**Figure 2.** Type MR95H/MR95HP Pilot Assembly

## Parts List (continued)

### Type MR95H/MR95HP Pilot

Key	Description
1	Regulator Body
2	Spring Case
3*	Orifice
4*	Valve Plug Assembly
5	Valve Plug Guide
6	Stem Assembly
7	Stem Guide Bushing
8	Lower Spring Seat
9	Upper Spring Seat
11	Regulator Spring
12*	Diaphragm
15	Adjusting Screw
16	Cap Screw
17	Jam Nut
18	Nameplate Drive Screw
26	Inner Valve Spring
63	Bottom Plug Seal

\*Recommended spare part

# Type LR125

---

## Industrial Regulators

### Emerson Process Management Regulator Technologies, Inc.

USA - Headquarters  
McKinney, Texas 75070 USA  
Tel: +1 800 558 5853  
Outside U.S. +1 972 548 3574

Asia-Pacific  
Shanghai 201206, China  
Tel: +86 21 2892 9000

Europe  
Bologna 40013, Italy  
Tel: +39 051 419 0611

Middle East and Africa  
Dubai, United Arab Emirates  
Tel: +971 4811 8100

## Natural Gas Technologies

### Emerson Process Management Regulator Technologies, Inc.

USA - Headquarters  
McKinney, Texas 75070 USA  
Tel: +1 800 558 5853  
Outside U.S. +1 972 548 3574

Asia-Pacific  
Singapore 128461, Singapore  
Tel: +65 6770 8337

Europe  
Bologna 40013, Italy  
Tel: +39 051 419 0611  
Chartres 28008, France  
Tel: +33 2 37 33 47 00

Middle East and Africa  
Dubai, United Arab Emirates  
Tel: +971 4811 8100

## TESCOM

### Emerson Process Management Tescom Corporation

USA - Headquarters  
Elk River, Minnesota 55330-2445, USA  
Tels: +1 763 241 3238  
+1 800 447 1250

Europe  
Selmsdorf 23923, Germany  
Tel: +49 38823 31 287

Asia-Pacific  
Shanghai 201206, China  
Tel: +86 21 2892 9499

For further information visit [www.fisherregulators.com](http://www.fisherregulators.com)

The Emerson logo is a trademark and service mark of Emerson Electric Co. All other marks are the property of their prospective owners. Fisher is a mark owned by Fisher Controls International LLC, a business of Emerson Process Management.

*The contents of this publication are presented for informational purposes only, and while every effort has been made to ensure their accuracy, they are not to be construed as warranties or guarantees, express or implied, regarding the products or services described herein or their use or applicability. We reserve the right to modify or improve the designs or specifications of such products at any time without notice.*

Emerson Process Management Regulator Technologies, Inc. does not assume responsibility for the selection, use or maintenance of any product. Responsibility for proper selection, use and maintenance of any Emerson Process Management Regulator Technologies, Inc. product remains solely with the purchaser.



**EMERSON**  
Process Management