

---

# **Rosemount Analytical**

## **MODEL 400A HYDROCARBON ANALYZER**

### **INSTRUCTION MANUAL**

748262-K

#### **NOTE**

**THIS MANUAL IS APPLICABLE TO MODEL 400A, CATALOG NUMBER 194106  
WITH SERIAL NUMBERS BEGINNING WITH 2000001**



## NOTICE

---

The information contained in this document is subject to change without notice.

Teflon<sup>®</sup> is a registered trademark of E.I. duPont de Nemours and Co., Inc.  
SNOOP<sup>®</sup> is a registered trademark of NUPRO Co.

Instruction Manual 748262-K  
July 1997  
Printed in USA

**Rosemount Analytical Inc.**  
4125 East La Palma Avenue  
Anaheim, California 92807-1802

---

---

# CONTENTS

---

---

## ***PREFACE***

SAFETY SUMMARY .....	P-1
SPECIFICATIONS.....	P-3
CUSTOMER SERVICE, TECHNICAL ASSISTANCE AND FIELD SERVICE ....	P-5
RETURNING PARTS TO THE FACTORY .....	P-5
TRAINING .....	P-5
DOCUMENTATION.....	P-5

## ***SECTION 1. INTRODUCTION***

1.1 DESCRIPTION .....	1-1
1.2 ANALYZER MOUNTING OPTIONS .....	1-1
1.3 FUEL GAS OPTIONS.....	1-2
1.4 OUTPUT OPTIONS.....	1-3
1.4.1 Isolated Remote Range Change and Identification .....	1-4
1.4.2 Range Trim Option.....	1-4
1.5 SAMPLE PUMP OPTION .....	1-4
1.6 GAS SAFETY FEATURES .....	1-4

## ***SECTION 2. INSTALLATION***

2.1 UNPACKING .....	2-1
2.2 LOCATION .....	2-1
2.3 VOLTAGE REQUIREMENTS.....	2-1
2.4 FUEL AND AIR REQUIREMENTS .....	2-2
2.4.1 Fuel Gas .....	2-2
2.4.2 Air .....	2-3
2.5 SAMPLE HANDLING.....	2-3
2.6 GAS CONNECTION .....	2-4
2.7 LEAK CHECK.....	2-6

---

## **SECTION 2. (CONTINUED)**

2.8	ELECTRICAL CONNECTIONS .....	2-6
2.8.1	Line Power Connections .....	2-6
2.8.2	Voltage Output Selection and Cable Connections for Recorder.....	2-7
2.8.3	Voltage to Current Output Board (optional) .....	2-7
2.8.4	Auxiliary Contacts.....	2-7
2.8.5	Remote Range Control and Indication .....	2-7
2.8.6	Sample Pump Accessory .....	2-9

## **SECTION 3. STARTUP AND CALIBRATION**

3.1	INITIAL STARTUP AND CALIBRATION.....	3-1
3.1.1	Selection of Calibration Method and Associated Standard Gas(es).....	3-4
3.2	CALIBRATION PROCEDURE .....	3-5
3.3	RANGE SWITCH.....	3-7
3.4	RANGE TRIM OPTION.....	3-8

## **SECTION 4. OPERATION**

4.1	ROUTINE OPERATION.....	4-1
4.2	RECOMMENDED CALIBRATION FREQUENCY .....	4-1
4.3	SHUTDOWN.....	4-1
4.4	OBTAINING MAXIMUM SENSITIVITY .....	4-2

## **SECTION 5. THEORY**

5.1	PRINCIPLE OF OPERATION .....	5-1
5.2	BURNER.....	5-1
5.2.1	Response to Different Hydrocarbons .....	5-2
5.3	ANALYZER FLOW SYSTEM.....	5-4
5.4	PREAMPLIFIER BOARD .....	5-4
5.5	MAIN ELECTRONICS BOARD .....	5-5
5.5.1	Post Amplifier .....	5-5
5.5.2	Digital Display.....	5-5
5.5.3	Span .....	5-6
5.5.3.1	Range Trim (Option).....	5-6
5.5.4	Remote Range Control.....	5-6
5.6	HEATER/FAN TEMPERATURE ASSEMBLY .....	5-6

---

**SECTION 5. (CONTINUED)**

5.7	IGNITION CIRCUIT .....	5-7
5.8	SYSTEM POWER SUPPLIES.....	5-7
5.9	FLAME-OUT BOARD.....	5-8

**SECTION 6. SERVICE AND TROUBLESHOOTING**

6.1	SYSTEM CHECKOUT .....	6-1
6.2	SERVICING FLOW SYSTEM AND BURNER .....	6-2
6.2.1	Burner Disassembly and Cleaning.....	6-3
6.2.2	Thermistor.....	6-4
6.2.3	Fuel and Air Restrictors .....	6-4
6.2.4	Sample Capillary.....	6-4
6.3	TROUBLESHOOTING .....	6-4

**SECTION 7. REPLACEMENT PARTS**

7.1	CIRCUIT BOARD REPLACEMENT POLICY .....	7-1
7.2	RECOMMENDED REPLACEMENT PARTS LIST.....	7-1

**GENERAL PRECAUTIONS FOR HANDLING & STORING HIGH PRESSURE CYLINDERS****WARRANTY****FIELD SERVICE AND REPAIR FACILITIES**

**FIGURES**

2-1	Range Input-Output Board.....	2-8
2-2	Range Control and Output Connections .....	2-10
3-1	Power Switch Location.....	3-2
3-2	Typical Curves of Downscale Response vs. Time for Various Hydrocarbons .....	3-5
3-3	Example 1 Display .....	3-7
3-4	Example 2 Display .....	3-8
3-5	Example 3 Display .....	3-8
3-6	Range Trim Option Schematic.....	3-9
4-1	Typical Curve of Analyzer Response vs. Pressure Setting on Sample Pressure Regulator.....	4-2
4-2	Typical Curves of Analyzer Response vs. Pressure Setting on Fuel Regulator .....	4-3
4-3	Typical Curves of Analyzer Response vs. Pressure Setting on Air Pressure Regulator.....	4-3
5-1	Flame Ionization Detection Theory .....	5-1
5-2	Typical Curves of Downscale Response vs. Time for Various Hydrocarbons .....	5-2

**TABLES**

1-1	Fuel Gas vs. Analyzer Characteristics .....	1-3
2-1	Range Control.....	2-8
3-1	Internal Pressure Regulators Settings .....	3-2
3-2	Range Switch Settings.....	3-7
5-1	Approximate Effective Carbon Numbers.....	5-3
5-2	Input Sensitivities .....	5-5
5-3	Fullscale Sensitivity.....	5-6
6-1	Troubleshooting .....	6-5

***DRAWINGS (LOCATED IN REAR OF MANUAL)***

620424	Schematic Diagram, Preamplifier
620429	Schematic Diagram, Main Electronics
620434	Schematic Diagram, Isolated V/I
622883	Flow Diagram, Model 400A
623190	Burner Parts List
624003	Schematic Diagram, Temperature Control Board
654328	Installation Drawing, Model 400A
654905	Schematic Diagram, Relay Board
654910	Schematic Diagram, Relay Board
654913	Assembly Instructions, I/O Board
654998	Assembly Instructions, Relay Board
655354	Pictorial Wiring Diagram, Model 400A
657546	Schematic Diagram, Flame-Out Board

# ***NOTES***



---

# PREFACE

---

## **SAFETY SUMMARY**

To avoid explosion, loss of life, personal injury and damage to this equipment and on-site property, all personnel authorized to install, operate and service the Model 400A Hydrocarbon Analyzer should be thoroughly familiar with and strictly follow the instructions in this manual. **Save these instructions.**

**DANGER** is used to indicate the presence of a hazard which **will** cause **severe** personal injury, death, or substantial property damage if the warning is ignored

**WARNING** is used to indicate the presence of a hazard which **can** cause **severe** personal injury, death, or substantial property damage if the warning is ignored.

**CAUTION** is used to indicate the presence of a hazard which **will** or **can** cause **minor** personal injury or property damage if the warning is ignored.

**NOTE** is used to indicate installation, operation, or maintenance information which is important but not hazard-related.



### **WARNING: ELECTRICAL SHOCK HAZARD**

*Do not operate without doors and covers secure. Servicing requires access to live parts which can cause death or serious injury. Refer servicing to qualified personnel.*



### **CAUTION: HIGH PRESSURE GAS CYLINDERS**

*For safety and proper performance this instrument must be connected to a properly grounded three-wire source of power.*

*This analyzer requires periodic calibration with known zero and standard gases. Refer to Sections 2.6, 3.8, 3.9, 3.10 and 3.11. See also General Precautions for Handling and Storing High Pressure Cylinders, following Section 7.*



**WARNING: POSSIBLE EXPLOSION HAZARD**

*Do not apply power to analyzer or ignite burner until all leak checks have been performed and until the environment of the analyzer has been determined to be non-hazardous. See Section 2.7 for leak check procedure.*

*This instrument uses a fuel containment hydrogen. The instrument is designed to protect against the formation of an explosive gas mixture within the enclosure. It must NOT be operated if the internal ventilation fan is not functioning. Do NOT operate without factory installed fuel flow restrictor in place.*

*Check the fuel supply and containment system for leaks, both inside and outside the analyzer, upon installation, before initial startup, during routine maintenance, or any time the integrity of the fuel containment system is broken, to assure that the system is leak-tight. Refer to Leak Check Procedure, Section 2.7, Step 6.*

*The enclosure is protected by a continuous dilution air purge system, as recommended in IEC\* Publication 79-2 (Third Edition - 1983). Do not operate unit unless the continuous dilution purge system is properly installed and functioning. Upon startup or loss of pressurization, purge for fifteen minutes before restoring power unless the internal atmosphere is known to be non-explosive.*



**WARNING: PARTS INTEGRITY**

*Tampering or unauthorized substitution of components may adversely affect safety of this product. Use only factory documented components for repair.*



**CAUTION: TOPPLING HAZARD**

*This instrument's internal pullout chassis is equipped with a safety stop latch located on the left side of the chassis.*

*When extracting the chassis, verify that the safety latch is in its proper (counter-clockwise) orientation.*

*If access to the rear of the chassis is required, the safety stop may be overridden by lifting the latch; however, further extraction must be done very carefully to insure the chassis does not fall out of its enclosure.*

*If the instrument is located on top of a table or bench near the edge, and the chassis is extracted, it must be supported to prevent toppling.*

*Failure to observe these precautions could result in personal injury and/or damage to the product.*

## SPECIFICATIONS

<b>POWER REQUIREMENTS:</b>	115 VAC $\pm$ 10%, 50/60 $\pm$ 3 Hz, 250 W
<b>OPERATING TEMPERATURE:</b>	32°F to 110°F (0°C to 43°C)
<b>CASE TEMPERATURE:</b>	Controlled at 122°F (50°C)
<b>AMBIENT HUMIDITY:</b>	95% relative humidity, but not in excess of 34°C wet bulb temperature.
<b>DIMENSIONS:</b>	8.75 in (22.2 cm) H 18.75 in. (47.6 cm) W 15.88 in. (39.7 cm) D Recommended panel cutout is 17.75 in. X 8 25 in. (45.1 cm x 21.0 cm). May be mounted in standard 19 inch rack.
<b>WEIGHT:</b>	22 lbs (10 kg)
<b>REPEATABILITY:</b>	1% of fullscale for successive identical samples
<b>RESPONSE TIME:</b>	90% of fullscale in 0.6 seconds with sample bypass flow at 3 liters/minute
<b>FULLSCALE SENSITIVITY STANDARD ANALYZER:</b>	Adjustable from 4 ppm CH <sub>4</sub> to 1% CH <sub>4</sub> . (Adjustable from 100 ppm CH <sub>4</sub> to 10% CH <sub>4</sub> using high-range capillary.)
<b>ANALYZER EQUIPPED WITH 100% HYDROGEN FUEL ASSEMBLY:</b>	Adjustable from 1 ppm CH <sub>4</sub> to 0.25% CH <sub>4</sub>
<b>FUEL GAS REQUIREMENTS STANDARD ANALYZER:</b>	75 to 80 cc/min premixed fuel consisting of 40% hydrogen and 60% nitrogen or helium (THC <0.5 ppm) supplied at 45 to 50 psig (309 to 344 kPa) at instrument
<b>ANALYZER EQUIPPED WITH 100% HYDROGEN FUEL ASSEMBLY:</b>	35 to 40 cc/min of clean, zero grade hydrogen (THC <0.5 ppm) at 45 to 50 psig (309 to 344 kPa) at instrument
<b>SAMPLE GAS REQUIREMENTS:</b>	Non-Flammable Samples - 0.35 to 3.0 liters/minute at 5 to 10 psig (34 to 69 kPa) Flammable Samples - 470 cc/minute maximum for safety <sup>1</sup>
<b>BURNER AIR REQUIREMENTS:</b>	350 to 400 cc/minute of zero grade (THC <1 ppm) air, supplied at 25 to 50 psig (172 to 344 kPa)
<b>SAMPLE BYPASS FLOW:</b>	0.3 to 3.0 liters/minute
<b>STABILITY:</b>	Electronic stability at maximum sensitivity is 1% of fullscale throughout ambient temperature range of 32°F to 110°F (0°C to 43°C). Built-in temperature controller minimizes effect of ambient temperature variations on internal flow and electronic systems.

<sup>1</sup> Safety design basis presumes flammable sample having LEL not less than that of hydrogen (4% v/v in air).

## SPECIFICATIONS (CONTINUED)

<b>RANGE:</b>	<p>Eight ranges: 1, 2.5, 10, 25, 100, 250, 1000 and REMOTE.                  In addition SPAN control provides continuously variable adjustment within a dynamic range of 4:1</p>
<b>OUTPUT:</b>	<p>1) 0 to 5 VDC, 0 to 1 VDC, 0 to 0.1 VDC fully buffered - standard (for 0 to 100.0%).                  2) 4 to 20 mA isolated voltage to current - optional (maximum load resistance 700 ohms)                  3) 0 to 5 VDC accessory output un-buffered - standard (for 0 to 100.0%) available when current option is not used.</p>
<b>SAFETY FEATURES:</b>	<p>Flame-on indication and automatic flame-out fuel shutoff is standard.                  All metal tubing with ferrule/nut compression fittings to minimize potential fuel leaks.                  Self-ventilated system maintains internal atmosphere below 25% of LEL for worst case internal leakage.</p>
<b>CONTACTS:</b>	<p>Form A contact operates in parallel with flame-out fuel shut-off solenoid contact rating (24 VDC at 1 A) for sample shut-off by use of factory ordered kit (PN 624080) if sample is flammable (hydrogen).</p>
<b>TEMPERATURE CONTROL:</b>	<p>Setpoint maintained at 122°F (50°C)</p>
<b>DATA DISPLAY:</b>	<p>3-1/2 digit LED, characters 0.52 inches high, range 0000 to 1999</p>
<b>RANGE DISPLAY:</b>	<p>1 digit LED, character 0.52 inches high (1 to 7 normal ranges, 0 to remote control)</p>
<b>REMOTE RANGE CONTROL:</b>	<p>Standard, fully isolated range control and range ID is optional</p>

---

## ***CUSTOMER SERVICE, TECHNICAL ASSISTANCE AND FIELD SERVICE***

For order administration, replacement Parts, application assistance, on-site or factory repair, service or maintenance contract information, contact:

**Rosemount Analytical Inc.  
Process Analytical Division  
Customer Service Center  
1-800-433-6076**

## ***RETURNING PARTS TO THE FACTORY***

Before returning parts, contact the Customer Service Center and request a Returned Materials Authorization (RMA) number. Please have the following information when you call: *Model Number, Serial Number, and Purchase Order Number or Sales Order Number.*

Prior authorization by the factory must be obtained before returned materials will be accepted. Unauthorized returns will be returned to the sender, freight collect.

When returning any product or component that has been exposed to a toxic, corrosive or other hazardous material or used in such a hazardous environment, the user must attach an appropriate Material Safety Data Sheet (M.S.D.S.) or a written certification that the material has been decontaminated, disinfected and/or detoxified.

Return to:

**Rosemount Analytical Inc.  
4125 East La Palma Avenue  
Anaheim, California 92807-1802**

## ***TRAINING***

A comprehensive Factory Training Program of operator and service classes is available. For a copy of the *Current Operator and Service Training Schedule* contact the Technical Services Department at:

**Rosemount Analytical Inc.  
Phone: 1-714-986-7600  
FAX: 1-714-577-8006**

## ***DOCUMENTATION***

The following Model 400A Hydrocarbon Analyzer instruction materials are available. Contact Customer Service or the local representative to order.

748262 Instruction Manual (this document)

# ***NOTES***

---

# 1 INTRODUCTION

---

## 1.1 DESCRIPTION

The Model 400A Hydrocarbon Analyzer automatically and continuously measures the concentration of hydrocarbons in a gas stream. Typical applications include monitoring atmospheric air for low-level hydrocarbon contaminants and determining the hydrocarbon content of exhaust emissions from internal combustion engines.

The analyzer utilizes the flame ionization method of detection. The sensor is a burner in which a regulated flow of sample gas passes through a flame sustained by regulated flows of a fuel gas and air. Within the flame, the hydrocarbon components of the sample stream undergo a complex ionization that produces electrons and positive ions. Polarized electrodes collect these ions, causing current to flow through an electronic measuring circuit. The ionization current is proportional to the rate at which carbon atoms enter the burner, and is therefore a measure of the concentration of hydrocarbons in the original sample. The analyzer provides readout on a front-panel digital display and a selectable output for an accessory recorder.

To ensure stable, drift-free operation, particularly in high-sensitivity applications, an internal temperature controller maintains the analyzer interior at a constant 50°C. This feature minimizes temperature-dependent variations in (a) electronic current-measuring circuitry, and (b) adsorption/desorption equilibrium of background hydrocarbons within the internal flow system.

To minimize system response time, an internal sample-bypass feature provides high-velocity sample flow through the analyzer.

The Model 400A may be equipped with various optional features in addition to, or instead of, the standard features of the basic instrument. The following paragraphs provide brief descriptions of the principal standard and optional features.

## 1.2 ANALYZER MOUNTING OPTIONS



### **WARNING: INSTALLATION**

***For safety, the analyzer should be installed in a non-confined, ventilated space.***

The standard analyzer is housed in a case designed for bench-top use, or if desired, the analyzer may be mounted in a cabinet or rack using RETMA spaced mounting holes. Outline dimensions are shown on DWG 654328.

### 1.3 FUEL GAS OPTIONS

For burner fuel gas, the standard analyzer requires 40% hydrogen/60% nitrogen or helium. Through installation of the optional 400A hydrogen fuel kit (P/N 622576), the analyzer may be converted to use 100% hydrogen. This kit may be ordered as a factory installed option or supplied as an option for installation by the user.

The preferred type of fuel depends on the particular application and the characteristics of the sample gas:

For measuring low-level hydrocarbons in ambient air, or in other sample gas with relatively constant oxygen content, 100% hydrogen is preferable. It provides the highest obtainable sensitivity and the maximum stability. Zero drift caused by ambient temperature variations of the fuel cylinder is somewhat lower for 100% hydrogen than for mixed fuel. (With either fuel, it is desirable to maintain cylinder temperature constant.)

For monitoring vehicular exhaust emissions, or other sample gas with varying oxygen content, mixed fuel is preferable; and a hydrogen/helium mixture is more desirable than a hydrogen/nitrogen mixture. With this type of sample, the use of mixed fuel gas minimizes the error introduced by oxygen synergism. An effective way to reduce the effect of internal oxygen is to dilute it with an inert gas. This might be accomplished by a constant dilution of sample and calibration gases ahead of the burner but it is simpler and more accurate to provide that diluent in the form of premixed fuel. Both nitrogen and helium have been used as a diluent, but helium has proven to be most effective in improving the equality of response to the various species of hydrocarbons.

As indicated earlier the flame output signal is optimum when the ratio of hydrogen flow to inert flow is about 40/60; therefore, this is the chosen composition for hydrogen/helium premixed fuel.

The sample flow is kept low to maximize the dilution effect while still providing adequate sensitivity. The burner air flow is normally about four times the fuel flow, and changes have little effect on signal strength. For a given sample flow, the signal can be optimized by adjusting the fuel flow rate.

Typical flow rates with premixed fuel:

Fuel	100 cc/min
Sample	7 cc/min
Air	400 cc/min



It is worth noting that with a 40/60 premixed fuel, the above flows amount to 40 cc (8%) hydrogen, 67 cc (13%) inert plus sample and 400 cc (79%) air, which compare closely to the 30 cc (8%) hydrogen, 45 cc (12%) inert/sample and 300 cc (80%) air given earlier for straight hydrogen fuel.

Since the sample flow in the case of mixed fuel operation is only about one-sixth of that with straight hydrogen fuel, it is clear that higher sensitivity is obtained with straight hydrogen fuel operation. However, in any application where the sample contains more than one species of hydrocarbon and/or a varying concentration of oxygen, the mixed fuel operation should be used.

The mixed fuel is recommended, not only for sample containing variable concentrations of oxygen, but also for two specific pure gas applications. The first is the case of pure hydrogen samples. The other is the case of pure oxygen samples. If straight oxygen samples are used with straight hydrogen fuel, the mixture entering the burner is essentially 40% H<sub>2</sub>/60% O<sub>2</sub>, which tends to produce an unstable signal. The mixed fuel works better. Note that the choice of fuel determines certain analyzer characteristics, as tabulated in Table 1-1.

## 1.4 OUTPUT OPTIONS

The standard analyzer provides (a) direct digital readout in percent of full scale on a front-panel display calibrated linearly from 0 to 100 %, (b) a selectable buffered output of 0 to 0.1 VDC, 1 VDC or 5 VDC suitable for a recorder and (c) a 0 to 5 VDC unbuffered accessory output.

An isolated output of 4 to 20 mA DC (max. load resistance 700 ohms) is obtainable through use of the optional current output board, P/N 620433, installed either during factory assembly or as a subsequent addition. When installed, this board uses the accessory 0 to 5 VDC output as an input signal and replaces this function at the output terminals.

<b>ANALYZER CHARACTERISTICS</b>	<b>100% H<sub>2</sub></b>	<b>40% H<sub>2</sub>/60% N<sub>2</sub> or 40% H<sub>2</sub>/He</b>
Fullscale Sensitivity	Adjustable from 1 ppm CH <sub>4</sub> to 2% CH <sub>4</sub>	Adjustable from 4 ppm CH <sub>4</sub> to 10% CH <sub>4</sub>
Fuel Consumption	35 to 40 cc/min	75 to 80 cc/min
Operating Range for SAMPLE Pressure Regulator	4 to 5 psig (27 to 34.5 kPa)	1.5 to 5 psig (10.3 to 34.5 kPa)

**TABLE 1-1. FUEL GAS VS. ANALYZER CHARACTERISTICS**

### 1.4.1 ISOLATED REMOTE RANGE CHANGE AND IDENTIFICATION

This option provides a 24 VDC operation of remote range and identification as well as providing terminals for flame out indication.

### 1.4.2 RANGE TRIM OPTION

This option provides individual potentiometers for each range to allow adjustment of individual differences in bottled gas.

## 1.5 SAMPLE PUMP OPTION

To provide the required sample flow, the sample gas must be under adequate pressure when applied to the analyzer inlet. Refer to Paragraph 2.4. To permit analysis of gases at atmospheric or sub-atmospheric pressure, the analyzer may be shipped with a sample pump accessory, P/N 621062.

## 1.6 GAS SAFETY FEATURES

The Model 400A is designed to provide a high degree of operational safety. In all analyzers, a front-panel LED indicates that the burner flame is lit. In addition, fuel gas is automatically shut off when a flame-out condition occurs.

All tubing ahead of the burner is rigid metallic tubing made up with ferrule/nut type compression fittings. However, should there be an internal fuel leak, an inlet fuel flow limiting restrictor, ventilation holes in the enclosure and an internal circulation fan serve to dilute and dissipate the hydrogen fuel for a worst case leak to a safety factor below 25% of the LEL of hydrogen. The design basis for this system presumes 100% hydrogen fuel at 50 psig inlet pressure. 40% hydrogen fuel and lower inlet pressure serve to further reduce hydrogen concentration in the event of a leak. In reality, an open fitting leak would never occur. As a leak developed the burner would eventually be starved of fuel and flame-out would occur at a leak equivalent of a loss of about 20 psig fuel pressure, thus actuating the fuel shut-off solenoid valve system.

If the sample is flammable, accessory kit P/N 624080, must be utilized. This kit provides a restrictor to limit sample flow and a solenoid valve to shut-off sample in the event of burner flame-out. The design basis for this kit presumes a maximum sample flow rate of 470 cc/min and a sample with LEL not below that of hydrogen (4% v/v in air).



### **WARNING: POSSIBLE EXPLOSION HAZARD**

***Protection against explosion depends upon special fuel flow limiting restrictor in fuel inlet fitting. Do not remove fuel inlet restrictor. Replace only with factory supplied fitting.***

---

---

# 2 INSTALLATION

---

---

## 2.1 UNPACKING

Carefully examine the shipping carton and contents for signs of damage. Immediately notify the shipping carrier if the carton or its contents are damaged. Retain the carton and packing materials until the instrument is operational.

## 2.2 LOCATION

Install analyzer in a clean area, not subject to excessive vibration or extreme temperature variations. Preferably, the analyzer should be mounted near the sample stream, to minimize sample-transport time.



### **WARNING: INSTALLATION RESTRICTIONS**

***For safety, the analyzer should be installed in a non-confined, ventilated space. Do not block any of the vent holes at the top of each side panel of the instrument as they are part of the safety system.***

A thermostatically controlled heating circuit holds internal temperature of the analyzer to the correct operating temperature for ambient temperatures in the range 32°F to 110°F (0°C to 43°C).

The cylinders of fuel, air, and calibration gas(es) should be located in an area of relatively constant ambient temperature.

## 2.3 VOLTAGE REQUIREMENTS



### **WARNING: ELECTRICAL SHOCK HAZARD**

***Do not operate without doors and covers secure. Servicing requires access to live parts which can cause death or serious injury. Refer servicing to qualified personnel.***

***For safety and proper performance this instrument must be connected to a properly grounded three-wire source of power.***

This instrument was shipped from the factory configured to operate on 115 VAC, 50/60 Hz electric power. Verify that the power source conforms to the requirements of the individual instrument, as noted on the name-rating plate.

**Note:**

**230 VAC operation requires an accessory transformer mounted external to the instrument. If external 230 VAC power is provided, do not change the switch setting on the Temperature Control Board, which is factory-selected for 115 VAC. A 230 VAC switch setting will cause the case temperature controller to malfunction.**

## 2.4 FUEL AND AIR REQUIREMENTS



### **WARNING: INSTALLATION RESTRICTIONS**

**Fuel, air and calibration gas cylinders are under pressure. Mishandling of gas cylinders could result in death, injury or property damage. Handle and store cylinders with extreme caution and in accordance with manufacturer's instructions. Refer to General Precautions for Handling and Storing Gas Cylinders, which follows Section 7 of this manual.**

During normal operation, the analyzer uses fuel and air to maintain the burner flame. Criteria for selection of these gases are given in Sections 2.4.1 and 2.4.2. In addition, the analyzer requires suitable standard gas(es) for calibration. Refer to Section 3.1.1.

Each gas used should be supplied from a tank or cylinder equipped with a clean, hydrocarbon-free, two-stage regulator. In addition, a shutoff valve is desirable. Install the gas cylinders in an area of relatively constant ambient temperature.

### 2.4.1 FUEL GAS

The standard analyzer is equipped to use only mixed fuel, i.e. 40% hydrogen/60% nitrogen or helium. Such blends are supplied by many gas vendors specifically for this use, with a guaranteed maximum total hydrocarbon content of 0.5 ppm, measured as methane (THC < 0.5 ppm). This specification should be used when buying such mixtures.

When the analyzer is equipped with the optional hydrogen fuel kit, P/N 622576, 100% hydrogen fuel is to be used. This is also supplied by many gas vendors specifically for this use, with the same guaranteed total hydrocarbon content (THC < 0.5 ppm) which, again, should be specified when buying the gas.

**Note:**

**Always assure the sample flow is present when using the 100% hydrogen fuel option. Absence of sample flow can result in burning of detector tip when using 100% hydrogen.**

## 2.4.2 AIR

Burner air should also be relatively free of hydrocarbons in order to assure a low background signal. Several grades of air are supplied by various gas vendors for this use. A maximum total hydrocarbon content of less than 1 ppm (THC < used as a zero standard).

An alternate source of pure air for burner and zero gas can be provided by a diaphragm pump and heated palladium catalyst which effectively removes moderate amounts of both hydrocarbons and carbon monoxide from normal ambient air on a continuous basis.

## 2.5 SAMPLE HANDLING



### **CAUTION: BYPASS GAUGE PROTECTION**

***When applying sample pressures greater than 5 psig, insure that the bypass regulator is fully open to protect the bypass gauge.***

Operating range for the internal sample pressure regulator is 4 to 5 psig (28 to 35 kPa) for an analyzer using 100% hydrogen fuel, and 1.5 to 5 psig (10 to 35 kPa) for an analyzer using mixed fuel. With either fuel, sample and calibration gas(es) must be supplied to the sample inlet at a pressure slightly, but not excessively higher than the desired setting on the internal sample pressure regulator. The criterion for correct supply pressure is that the gas flow discharged from the by-pass outlet must be between 0.5 and 3.0 liters/minute to operate within the control range of the sample pressure regulator, and preferably should be between 2 and 3 liters/minute to minimize system response time.

Note that use of excessive bypass flow will not only cause the sample pressure regulator to operate outside its control range, but will also result in rapid depletion of sample and standard gases.

If the analyzer is equipped with the accessory 400A sample pump, P/N 621062, the acceptable pressure range at the pump inlet is approximately -1 to +2.5 psig (7 to 17 kPa). If the pump is used, it will automatically provide a sample bypass flow within the correct range. If the analyzer is not equipped with sample pump, adjustment of the bypass flow is obtainable by inserting an external flow controller or throttle valve into the external sample line, upstream from the sample inlet. Flow may be measured by connecting a flowmeter to the by-pass outlet.

**WARNING: POSSIBLE EXPLOSION HAZARD**

*In the event that flammable sample is to be introduced into this analyzer, it must be equipped with accessory kit PN 624080, which restricts sample flow and provides automatic sample shutoff in the event of burner flameout. DO NOT OPERATE WITHOUT SAMPLE FLOW RESTRICTOR IN PLACE. The sample containment system should also be thoroughly leak checked. This kit is designed considering application on hydrogen sample (LEL=4% v/v). The instrument must not be used on a sample having a LEL less than 4% in air.*

## 2.6 GAS CONNECTION

For external gas lines, the use of all new tubing throughout is strongly recommended. Copper refrigeration tubing is preferred. Stainless steel tubing is less desirable, because it contains hydrocarbon contaminants, necessitating thorough cleaning before installation.

In connecting gas supply lines and associated fittings, use Teflon tape only. Do not use pipe thread compound or other substance with an organic base.

**WARNING: POSSIBLE EXPLOSION HAZARD**

*Do not apply power to analyzer or ignite burner until all leak checks have been performed and until the environment of the analyzer has been determined to be non-hazardous. See Section 2.7 for leak check procedure.*

*This analyzer has been designed for use in environments that do not contain combustible or explosive materials.*

*This analyzer uses a fuel containing hydrogen. Leakage from the fuel containment system can result in an explosion. The fuel supply and containment system, both inside and outside the analyzer, should be carefully checked for leaks upon installation, before initial startup, during routine maintenance or any time the integrity of the sample containment system is broken.*

*If hazardous sample is to be introduced into this analyzer, the leak check procedure should also be applied to the sample containment system, both inside and outside the analyzer.*

Proceed as follows:

1. Check analyzer to make sure that plugs and caps are removed from all inlet and outlet fittings.

2. If a vent line is to be connected to exhaust outlet, use 1/2-inch ID tube slanted downward at least 10 degrees from horizontal.

**Note:**

***Since water vapor is formed during oxidation of hydrogen, burner exhaust gas always contains moisture, even if air and fuel entering the burner are completely dry. Unless exhaust line slants down, water may accumulate in line, causing back pressure and noisy readings. If exhaust line becomes blocked, water may back up in line and flood burner.***

3. If sample is toxic or noxious, or is to be reclaimed, connect by-pass outlet to suitable disposal system. Do not use any device causing back pressure on burner.
4. Clean external fuel, air, and sample lines and regulators. If necessary, heat lines with torch to drive out contaminants.



**CAUTION: DISCONNECT ALL LINES**

***Do not perform this operation with the fuel, air and sample lines connected to the analyzer***

5. Recommended method is to attach the tubing to either a nitrogen or helium cylinder through a two-stage regulator, and adjust the regulator for a low flow of gas through the tubing. Use a propane or natural gas torch to heat the tubing to at least 300°C, working the heat source slowly from the regulator end to the open end. This will remove contaminants from the inside walls of the tubing, and drive them out the open end.
6. Connect external fuel and air lines to fuel and air inlet fittings on analyzer. Connect external sample line to sample inlet on analyzer (or to inlet fitting on sample pump, if used).
7. Adjust regulators on fuel and air cylinders (or other gas supply sources) for appropriate output pressure. Maximum permissible pressure at AIR and FUEL inlets of analyzer is 50 psig (345 kPa). The pressure at the AIR inlet must be at least 5 psig (35 kPa) higher than the desired setting on the air pressure gauge within the analyzer. Thus if the internal FUEL pressure regulators are to be set at a typical value of 25 psig (172 kPa), the pressure at the FUEL inlet must be set 15 to 20 pounds higher than the operating pressure.
8. Supply sample gas at appropriate pressure, as explained in Section 2.5. Sample bypass flow must be between 0.5 and 3.0 liters/minute for proper operation. Preferably, it should be between 2.0 and 3.0 liters/minute, to minimize system response time. Flow may be measured by connecting a flowmeter to BY-PASS outlet.

## 2.7 LEAK CHECK



### **WARNING: POSSIBLE EXPLOSION HAZARD**

***Be particularly careful in checking for leaks in the fuel lines. Fuel gas leakage can cause an explosion.***

Check all gas connections to ensure that they are leak free. Use of SNOOP (P/N 837801) or other suitable leak-test liquid is recommended. Do not use soap or other organic substances; they will contaminate the system, resulting in excessive noise and background current. To leak check the fuel containment system, it is necessary to have full operating pressure within the system. To accomplish this, hold the momentary IGNITE/PURGE switch in the up or PURGE position.

## 2.8 ELECTRICAL CONNECTIONS



### **WARNING: POSSIBLE EXPLOSION HAZARD**

***Before supplying electrical power to analyzer, complete the gas connections and verify that fuel gas connections are leak free. Refer to Section 2.7.***



### **WARNING: ELECTRICAL SHOCK HAZARD**

***Do not operate without doors and covers secure. Servicing requires access to live parts which can cause death or serious injury. Refer servicing to qualified personnel.***

***For safety and proper performance this instrument must be connected to a properly grounded three-wire source of power.***

### 2.8.1 LINE POWER CONNECTION

The Model 400A is manufactured to operate only on 115 VAC power. (Note that the power input box and power selection card display only 115 VAC operation.)

The power cable supplied is provided with a North American-style parallel blade grounded plug which must be inserted into a 3-wire grounded receptacle.

If 230 VAC operation is desired, an external isolated step-down transformer accessory (not supplied) is required.



## 2.8.2 VOLTAGE OUTPUT SELECTION AND CABLE CONNECTIONS FOR RECORDER

The standard analyzer provides voltage output only. As shipped from the factory, the analyzer is set up for use with a 100 mV recorder (program header connecting pins E9 and E10).

A selection of three voltage output ranges, 0 to 0.1 VDC, 0 to 1.0 VDC or 0 to 5.0 VDC are available at terminals 3 and 4 of the lower six-position barrier strip labeled OUTPUT. Refer to Figure 2-1. To select 0 to 1.0 VDC range, connect pins E7 and E8 on the main electronics board assembly, P/N 620428, with the program header. For the 0 to 5.0 VDC range, connect pins E5 and E6, and for the 0 to 0.1 VDC range, connect pins E9 and E10, with the program header. This is a fully buffered signal and can be used with most types of voltage recorders. A 10 VDC output displays 1999 on digital readout, indicating 99.9% overrange. A 5 VDC output displays 1000 on digital readout and indicates 100%, the normal instrument span.

## 2.8.3 VOLTAGE TO CURRENT OUTPUT BOARD (OPTIONAL)

The optional current output in the range of 4 to 20 mADC appears at terminals 5 and 6. Refer to Figure 2-1. This current may be transformed back to a voltage using the appropriate resistor. This fully isolated current board is an instrument option and mounts internally on the Model 400A front panel assembly. The maximum value of load resistor is 700 ohms. The 4 to 20 mA is valid over the range of 0 to 100%; the overrange capability of 99.9% is not usable with this option because maximum output of 20 mA corresponds to 5 VDC out.

If the voltage to current option is not utilized, insert program header connecting pins E1/E2 and E3/E4 on the main electronics board assembly to allow a voltage to appear at terminals 5 and 6 in place of the current.

## 2.8.4 AUXILIARY CONTACTS

A Form A contact closure is available on pins 1 and 2 of the lower barrier strip at the rear of instrument. Refer to Figure 2-1. These contacts may be used with an existing alarm panel or annunciator system, providing the current and voltage limits are observed. The rating for the contacts is 24 V at 1A DC. Contacts operate in parallel with the internal fuel shutoff solenoid and may therefore be used for external "flame out" indication.

## 2.8.5 REMOTE RANGE CONTROL AND INDICATION

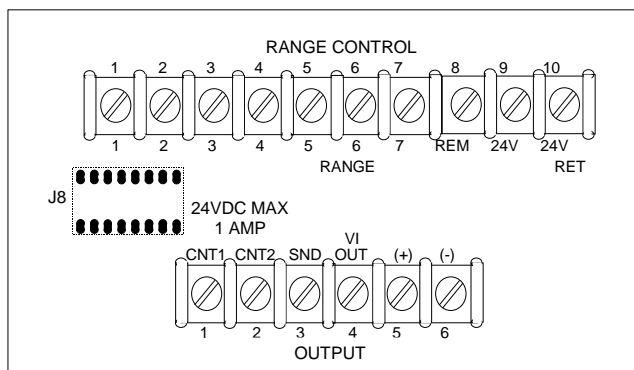
The Model 400A allows remote control of range or alternatively remote control indication; this is standard with each unit. As an option, a fully isolated interface may be installed. It performs the same function but assures electrical isolation between the analyzer and the control or indication module. The isolated range/indication option requires an external 24 VDC power supply for operation.

### RANGE CONTROL (NON-ISOLATED)

Terminals 1 through 7 on the upper terminal block at the rear of the instrument are used for this function. Select RMT on the front panel RANGE switch. Connect the respective line, 1 through 7, to pin 3 (labeled GND) on the lower barrier strip. The front panel will indicate the range selected. Terminals 1 through 7 correspond to ranges 1 through 7. Table 2-1 shows a simple range selection arrangement.

### RANGE INDICATION (NON-ISOLATED)

When the RANGE switch is in any position, including RMT, the range selection of the instrument may be determined by sensing an output in terminals 1 through 8 on the upper terminal strip at the rear of the instrument. Any selected range, 1 through 7 or RMT (position 8), will be indicated as a low or ground signal with respect to pin 3 of the lower barrier strip labeled GND; all un-selected ranges will indicate a high or +5 VDC with respect to this same terminal.



**FIGURE 2-1. RANGE INPUT-OUTPUT BOARD**

LOWER TB		UPPER TB						
Terminal 3		1	2	3	4	5	6	7
Range 1	X	X						
Range 2	X		X					
Range 3	X			X				
Range 4	X				X			
Range 5	X					X		
Range 6	X						X	
Range 7	X							X

**TABLE 2-1. RANGE CONTROL**

## ISOLATED REMOTE RANGE CONTROL AND IDENTIFICATION

The Remote Control Assembly is located on the rear panel of the instrument and is shown in Figure 2-2. Connections should be made to the terminals marked Range Control where a single line interference is desired. By removing steering diodes on printed circuit board 654910, individual Range Control and Range I/O connections may be made. Connections are made to bare wire terminal which are easily removable to facilitate installation.

Wires should not be tinned prior to installation to prevent premature loosening.

### **Note:**

***The terminal strips on the module use screws to secure bare wires. These wires should not be tinned or they may loosen prematurely.***

Range changes are achieved by applying 24VDC at about 150 mW to the terminals marked "range control," using the common terminal as return. Only one range may be selected at once. Range indication is achieved by individual 24 VDC (1 A) relay contacts.



### **WARNING: ELECTRICAL HAZARD**

***Range indication relay contacts are limited to 24 VDC. Use of 115 VAC is unsafe.***

Common control/sense connections may be made to the range control terminals.

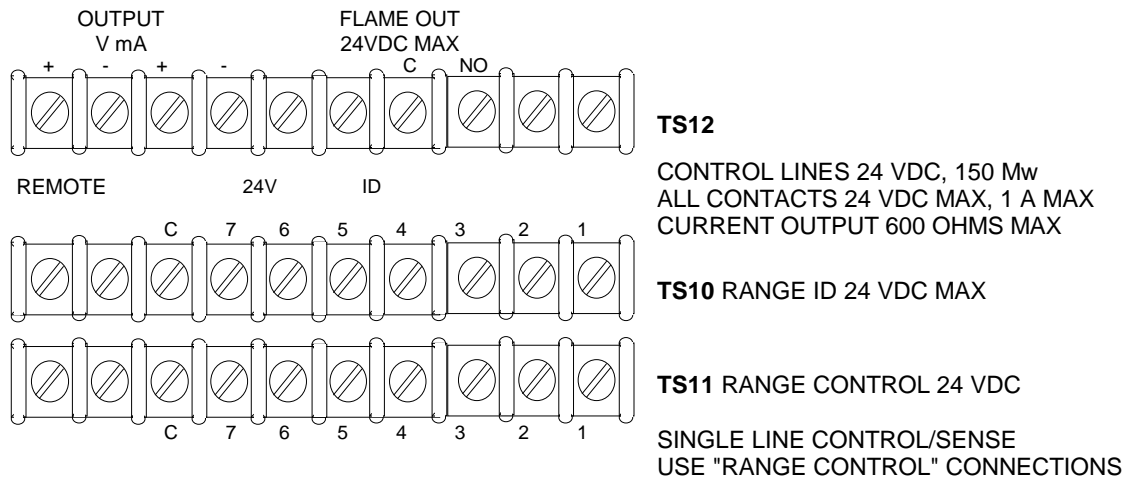
Voltage and current output signals are also available on the range change module. Voltage output must be used with a load of greater than 10 kilohms, current output with less than 600 ohms. Voltage output interconnects should be shielded (use the V-output for shield connection) but current output shielding is less critical. If used, current output shielding should be grounded on the reception end (computer or chart recorder).

## REMOTE FLAME OUT INDICATION

Terminals for flame out indication (TS12) are shown in Figure 2-2.

### 2.8.6 SAMPLE PUMP ACCESSORY

If a sample pump is used, 115 VAC, 50/60 Hz power must be provided to the pump accessory independently. A power cord is provided with this option and mates with a standard 3-pin power connector at the rear of the housing.



**FIGURE 2-2. RANGE CONTROL AND OUTPUT CONNECTIONS**

---

# 3 STARTUP AND CALIBRATION

---

## 3.1 INITIAL STARTUP AND CALIBRATION

Section 3.1.1 discusses calibration methods and the associated standard gases. Section 3.2 explains the typical calibration procedure.

After installing analyzer per Section Two, proceed as follows:

1. Set the RANGE multiplier switch (located inside the small door on the analyzer front panel) at 1000. Place POWER switch (located in the upper right-hand corner of the main electronics board on the back of the front panel) at ON. See Figure 3-1. The display should light up.
2. Set external regulators on air and fuel cylinders (or other gas supply sources) for suitable output pressure. Maximum permissible pressure at AIR and FUEL inlets of analyzer is 50 psig (345 kPa). The pressure at the AIR inlet must be at least 5 psig (25 kPa) higher than the desired setting on the air pressure gauge within the analyzer. The internal FUEL pressure regulator is to be set at a typical value of 25 psig (172 kPa), the pressure at the FUEL inlet must be set at least 20 lbs. higher than the operation pressure.
3. If analyzer uses 100% hydrogen fuel, supply actual sample or other suitable gas to SAMPLE inlet port of analyzer (or to inlet fitting on sample pump, if provided). Note pressure and flow requirements explained in Section 2.4.



### **CAUTION: POSSIBLE BURNER DAMAGE**

***If analyzer uses 100% hydrogen fuel, an adequate flow of sample or other gas must enter sample inlet at all times when flame is burning. Otherwise, burner will overheat and damage burner tip.***

If analyzer uses mixed fuel, sample flow may be initiated at this time, although it is not necessary.

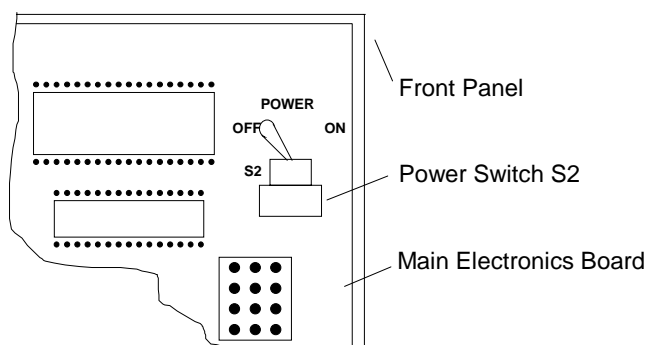
4. Set internal pressure regulators at values appropriate to the fuel gas used. Refer to Table 3-1.

Internal Pressure Regulator	Fuel Gas	
	<u>100% H2 Fuel</u> psig/kPa	<u>Mixed Fuel</u> psig//kPa
Air	5/35	5/35
Fuel	25/175	30/207
Sample	5/35	0/0

**TABLE 3-1. INTERNAL PRESSURE REGULATORS SETTINGS**

The PURGE/IGNITE switch has two positions, IGNITE and PURGE.

- With PURGE/IGNITE switch in PURGE position, wait about one minute for fuel gas to purge flow system. During purging period, rotate FUEL pressure regulator alternately clockwise and counterclockwise several times, then return to setting specified in Step 4.
- Briefly hold (2 to 4 sec.) PURGE/IGNITE switch in IGNITE position, then release. FLAME indicator should now be ON, indicating that flame is burning. If so, proceed with following steps. If FLAME indicator does not stay on, the flame is not burning. Again actuate IGNITE switch. If flame does not ignite after several attempts, refer to troubleshooting chart, Table 6-1. If difficulty is experienced, allowing gas to flow for 20 or 30 seconds in the PURGE position prior to actuating the IGNITE switch may be helpful.



**FIGURE 3-1. POWER SWITCH LOCATION**

**Note:**

***If ignition indication [FLAME ON] is observed without obtaining proper sensitivity, refer to Table 6-1, Item 6.***

**Note:**

***When lighting the burner after extended shutdown, the instrument will require time to allow fuel to reach the burner. Therefore, extended operation of the switch may be required.***

7. Increase setting on internal AIR pressure regulator to at least 15 psig (103 kPa). Recommended operating settings for internal pressure regulators are AIR, 15 psig (103 kPa); FUEL, 25 psig (172 kPa). Verify that FLAME indicator is still on.

The analyzer is equipped with an automatic fuel shutoff solenoid. If flame goes out during subsequent operation, fuel gas flow will shut off automatically.

If analyzer has been in regular use, it is now ready for calibration, per Section 3.2.1, and then for normal operation. However, during initial startup, or startup following a prolonged shutdown, the following steps should first be performed.

8. Check for contamination in air and fuel systems:
  - a. Supply a clean, hydrocarbon-free gas, such as pure nitrogen to the SAMPLE inlet. Adjust external flow controller or throttle valve so that flow discharged from BY-PASS outlet is between 0.5 and 3.0 liters/minute (preferably between 2.0 and 3.0 liters/minute). Set internal SAMPLE pressure regulator at 5.0 psig (34.5 kPa).
  - b. Set RANGE switch at 10, SPAN control at 1000 (maximum sensitivity), and ZERO control at 1000 (minimum zero suppression). Approximate fullscale sensitivity is now 10 ppm as methane for mixed fuels if the analyzer uses 100% hydrogen fuel, and 40 ppm methane if the analyzer uses mixed fuel.
  - c. Check display. Maximum acceptable reading is 50% of fullscale. A higher reading indicates that the contamination level is undesirably high. Excessive noise and baseline drift may result, depending on the desired operating range. If the instrument is to be operated at high sensitivity, the source of the contamination must be determined and the condition corrected. The most probable contamination sources are the fuel and air supplies, external regulators and connecting lines, and the internal flow system of the analyzer.

If the instrument is to be operated at a sensitivity low enough so that the noise and drift will not be observable on the display or recorder, removal of the source of contamination is unnecessary.

9. With flame burning, allow system to stabilize for at least two hours, and preferably for a day. After initial startup, or after startup following a prolonged shutdown, the analyzer may display baseline drift for a considerable period of time, particularly on the more-sensitive ranges. Commonly, small amounts of hydrocarbons are present on the inner walls of the tubing in both the internal flow system and the external gas-supply system. Drift results from any factor influencing the equilibrium of these absorbed hydrocarbons. Typical causes are change of fuel cylinders or change in temperature or pressure. (Note that this type of drift occurs only when the flame is burning. If drift occurs when the flame is extinguished, the electronic circuitry is at fault.)

To minimize drift, use clean fuel and air, keep the analyzer clean, and locate the gas cylinders in an area of relatively constant ambient temperature.

### **3.1.1 SELECTION OF CALIBRATION METHOD AND ASSOCIATED STANDARD GAS(ES)**

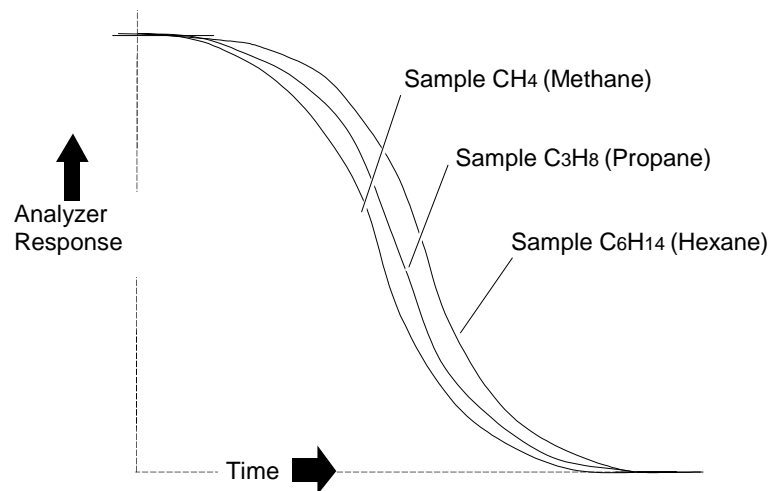
Preparatory to normal operation of the analyzer, it is necessary to select a suitable calibration method and appropriate standard gas(es). Proper choice depends on the type of fuel gas, the intended operating range, and the desired accuracy. In all methods, the objective is to establish both a downscale point and an upscale point on the display or recorder chart. Different methods are described below.

#### **DOWNSCALE CALIBRATION POINT**

The downscale calibration point is set with the ZERO control, by the appropriate one of two methods:

1. The generally preferred method is to adjust the ZERO control while a zero standard gas of low, accurately-known, hydrocarbon content is entering the SAMPLE inlet port. This method is desirable with all analyzers, and is mandatory if the analyzer utilizes 100% hydrogen fuel. Typically, nitrogen (zero gas grade) is used as the zero gas. If desired, the burner air may be used as zero gas, provided that its hydrocarbon content is sufficiently low and accurately known. Although ideally the zero gas should be completely hydrocarbon-free, even the most carefully prepared bottled gas contains trace hydrocarbons. If the analyzer is to be used at high sensitivity, request that the supplier of the zero gas provide an exact determination of its hydrocarbon content.
2. If the analyzer utilizes mixed fuel, an alternative method eliminates the requirement for a special zero gas. Instead, the ZERO control is adjusted with no gas entering the SAMPLE inlet. This method is not possible with analyzer utilizing 100% hydrogen fuel, because the burner would overheat. Even with mixed fuel, the method is not recommended if the analyzer is to be used at sensitivity less than 100 ppm full scale.
3. Refer to Figure 3-2 for typical curves of downscale response versus time for various hydrocarbons.





**FIGURE 3-2. TYPICAL CURVES OF DOWNSCALE RESPONSE VS. TIME FOR VARIOUS HYDROCARBONS**

### UPSCALE CALIBRATION POINT

In all applications, the upscale calibration point is established by adjustment of the SPAN control, while a standard gas of accurately known hydrocarbon content is flowing into the SAMPLE inlet port. Since instrument response is linear, it is not necessary that the hydrocarbon content of the span gas fall within the desired operating range. The instrument may be standardized on one range, and then switched to another range without loss of accuracy. Commonly, a conveniently obtained standard such as 100 ppm methane or 1000 ppm methane is used regardless of range.

A span gas consists of a specified concentration of methane or other hydrocarbon in a background gas such as nitrogen. Instrument response is affected by the composition of the background gas. Therefore, it is desirable that the span gas contain the same background gas as the actual sample. If so, the background effect is automatically canceled out.

### STANDARD GAS(ES)

Upscale standard gas (and zero standard gas, if used) should be supplied from a tank or cylinder equipped with a clean, hydrocarbon-free, two-stage pressure regulator.

## 3.2 CALIBRATION PROCEDURE

After completing startup procedure of Section 3.1.1, calibrate analyzer as explained below.

1. Set downscale calibration point as follows:

- a. Supply zero gas to SAMPLE inlet. Adjust external flow controller or throttle valve so that flow discharge from BY-PASS outlet is between 0.5 and 3.0 liters/minute (preferably between 2.0 and 3.0 liters/minute). Set internal SAMPLE pressure regulator at 5 psig (34 kPa) or other desired value. (Recommended operating range is 4 to 5 psig [28.6 to 34 kPa] for analyzer using 100% hydrogen fuel, and 1.5 to 5 psig [10 to 34 kPa] for analyzer using mixed fuel.)



**CAUTION: POSSIBLE BURNER DAMAGE**

***If analyzer uses 100% hydrogen fuel, an adequate flow of sample or other gas must enter sample inlet at all times when flame is burning. Otherwise, burner will overheat and damage burner tip.***

- b. Set RANGE switch at 10 and SPAN potentiometer at 1000. The resultant approximate fullscale sensitivity is 10 ppm methane for an analyzer using 100% hydrogen fuel, and 40 ppm methane for an analyzer using mixed fuel.
  - c. Adjust ZERO control for reading of zero (or appropriate near-zero value) on indicator or recorder. The resultant setting on the ZERO control is approximately correct, and is sufficiently accurate for most applications. However, if instrument is to be used for high sensitivity analysis, a recheck and possible slight readjustment will be made. Refer to Section 4.4.
2. Set upscale calibration point as follows:
- a. Turn RANGE switch to setting appropriate to the particular span gas. Refer to Table 3-2.
  - b. Supply span gas to SAMPLE inlet. Adjust external flow controller or throttle valve so that flow discharged from BY-PASS outlet is between 0.5 and 3.0 liters/minute (preferably between 2.0 and 3.0 liters/minute). Verify that reading on internal SAMPLE pressure gauge is 5 psig or other desired value; if not, adjust SAMPLE pressure regulator as required.
  - c. Adjust SPAN control so that the display or recorder gives the desired indication. Lock SPAN control by pushing lever down.

Analyzer calibration is now sufficiently accurate for most applications. However, if instrument is to be used for high sensitivity analysis, recheck zero setting (refer to Section 4.4). If recorder readout and display do not agree, correct display by adjusting R1 on front panel board.

- d. Supply zero gas to SAMPLE inlet as in Step 1a. Set RANGE switch at 10. Note reading on indicator or recorder; if incorrect, adjust ZERO control as required. Lock ZERO control by pushing lever down. Analyzer is now ready for routine operation as explained in Section 4.

RANGE SWITCH SETTINGS	APPROXIMATE OPERATING RANGE SPAN CONTROL AT 1000	
	1	0 to 1 ppm CH <sub>4</sub>
2.5	0 to 2.5 ppm CH <sub>4</sub>	0 to 10 ppm CH <sub>4</sub>
10	0 to 10 ppm CH <sub>4</sub>	0 to 40 ppm CH <sub>4</sub>
25	0 to 25 ppm CH <sub>4</sub>	0 to 100 ppm CH <sub>4</sub>
100	0 to 100 ppm CH <sub>4</sub>	0 to 400 ppm CH <sub>4</sub>
250	0 to 250 ppm CH <sub>4</sub>	0 to 1000 ppm CH <sub>4</sub>
1000	0 to 1000 ppm CH <sub>4</sub>	0 to 4000 ppm CH <sub>4</sub>

Note: For best results, calibrate with appropriate span gas every time the range is changed. For a clear understanding of the function of the Range Switch, see Section 3.3.

**TABLE 3-2. RANGE SWITCH SETTINGS**

### 3.3 RANGE SWITCH

The operator can choose from seven range multipliers as represented by the settings on the Range Switch: 1, 2.5, 10, 25, 100, 250, and 1000.

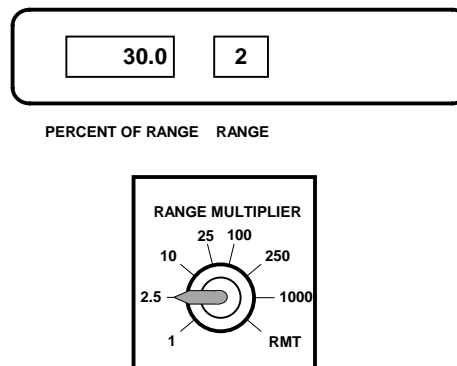
Range 1 is the most sensitive, range 1000 the least sensitive. Range 1 is 10 times more sensitive than Range 10 and so forth.

The Range Switch settings (multipliers) and the display outputs do not represent hydrocarbon concentrations in percent or ppm. The LED display shows the percent of the fullscale range which has been calibrated on the multiplier selected. The display also shows which range multiplier has been selected on the Range Switch (1 = 1, 2 = 2.5, 3 = 10, 4 = 25, 5 = 100, etc.).

Range 1 has a maximum sensitivity of 1 ppm CH<sub>4</sub> (as 100% fullscale) if 100% H<sub>2</sub> fuel is used, or 4 ppm CH<sub>4</sub> if mixed fuel is used. Range 2.5 has a maximum sensitivity of 2.5 ppm CH<sub>4</sub> with 100% H<sub>2</sub>, 10.0 ppm CH<sub>4</sub> with mixed fuel.

#### EXAMPLE 1:

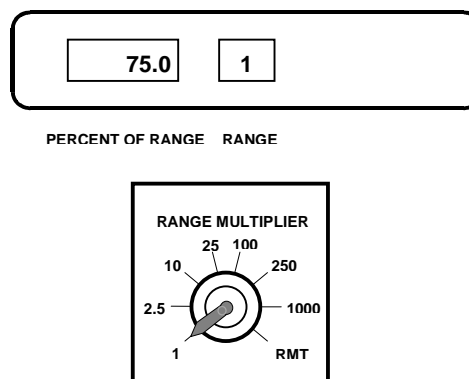
With the Range Switch set at 2.5, the operator can use, for example, 6 ppm CH<sub>4</sub> span gas to calibrate the instrument for 20 ppm fullscale (30.0% x 20 ppm CH<sub>4</sub> = 6.0 ppm). See Figure 3-3 for display output and Range Switch setting.



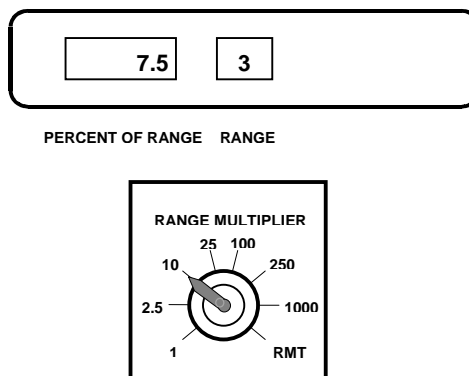
**FIGURE 3-3. EXAMPLE 1 DISPLAY**

**EXAMPLE 2:**

After the calibration in Example 1, Range 10 is now automatically calibrated for 80 ppm CH<sub>4</sub> as 100% fullscale. (Note that Range 10 is 4 times less sensitive than Range 2.5). Therefore, when the operator switches from Range 2.5 to Range 10, the display will show 7.5% fullscale for ppm CH<sub>4</sub> calibration gas since  $7.5\% \times 80$  ppm CH<sub>4</sub> = 6.0 ppm CH<sub>4</sub>. See Figure 3-4.

**FIGURE 3-4. EXAMPLE 2 DISPLAY****EXAMPLE 3:**

Likewise, after the calibration in Example 1, Range 1 is automatically calibrated for 8 ppm as 100% fullscale. Therefore, when switching from Range 2.5 to 1 (which is 2.5 times more sensitive than 2.5), the display will show 75.0% fullscale for 6.0 ppm CH<sub>4</sub> calibration gas (because  $75.0\% \times 8$  ppm CH<sub>4</sub> = 6 ppm CH<sub>4</sub>). See Figure 3-5.

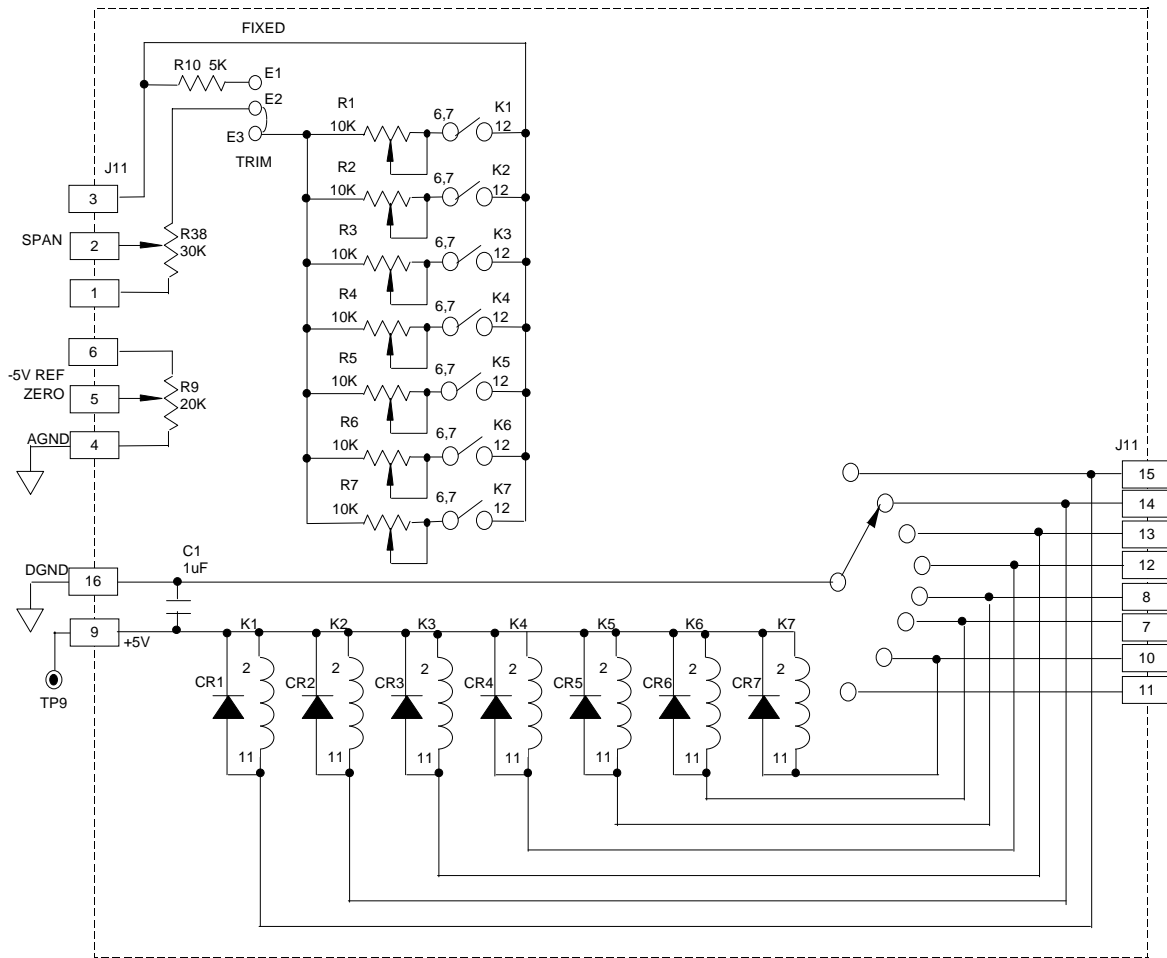
**FIGURE 3-5. EXAMPLE 3 DISPLAY****Note:**

***The precision of the analyzer is  $\pm 1\%$  fullscale of range. Analyzer should be calibrated with a span gas that has a hydrocarbon concentration as close to the fullscale concentration as possible.***

**3.4 RANGE TRIM OPTION**

The Range Trim option allows the user to adjust each range separately to compensate for differences between calibration gas cylinders from range to range.

See Figure 3-6. The E1, E2 and E3 jumpers allow selection from "fixed" front span potentiometer use to "trim" individual potentiometers for each range. In the trim position, the adjustment range of the individual pot is about 20% when the front panel span pot is set fully clockwise. If the front panel span pot is set fully counterclockwise, the individual pot range is about 5%.



**FIGURE 3-6. RANGE TRIM OPTION SCHEMATIC**

## ***NOTES***

---

# 4 OPERATION

---

## 4.1 ROUTINE OPERATION

After calibrating instrument per Paragraph 3.2, proceed as follows:

Supply sample gas to SAMPLE inlet. Adjust external flow controller or throttle valve so that flow discharged from BY-PASS outlet is between 0.5 and 3.0 liters/minute (preferably between 2.0 and 3.0 liters/minute). Note reading on BY-PASS pressure gauge. It should be the same as that used during adjustment of the SPAN control; if not, adjust SAMPLE pressure regulator as required.

Turn RANGE switch to appropriate position. Indicator (and recorder, if used) will now automatically and continuously indicate the hydrocarbon content of the sample. Normally, readout is in terms of CH<sub>4</sub>, since this is the particular hydrocarbon present in the usual span gas. Note that readings obtained during operation depend on the type, as well as the concentration, of hydrocarbons in the sample.

If maximum accuracy and stability are desired, observe the operating requirements explained in Section 4.4.

## 4.2 RECOMMENDED CALIBRATION FREQUENCY

After initial startup, or startup following a prolonged shutdown, the analyzer requires about one day for stabilization. For the first few days thereafter, calibrate daily. Subsequently, the frequency of calibration can be reduced as experience dictates, consistent with the accuracy requirements of the particular application.

## 4.3 SHUTDOWN

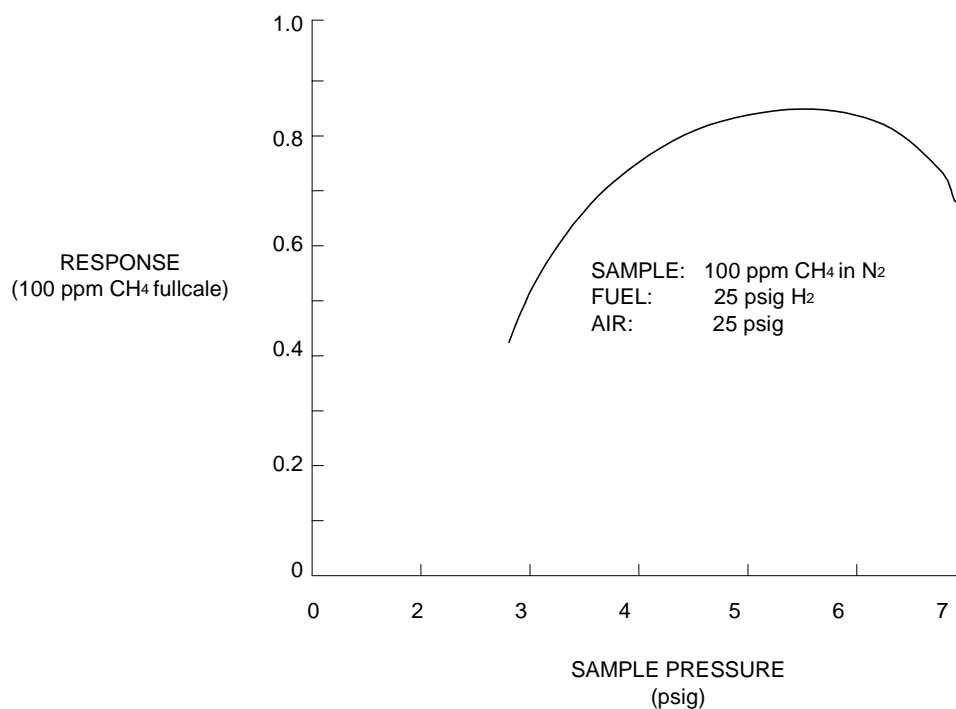


### **WARNING: SHUTDOWN PROCEDURE**

*For safety in shutdown, always turn off fuel gas first, then the air and sample lines.*

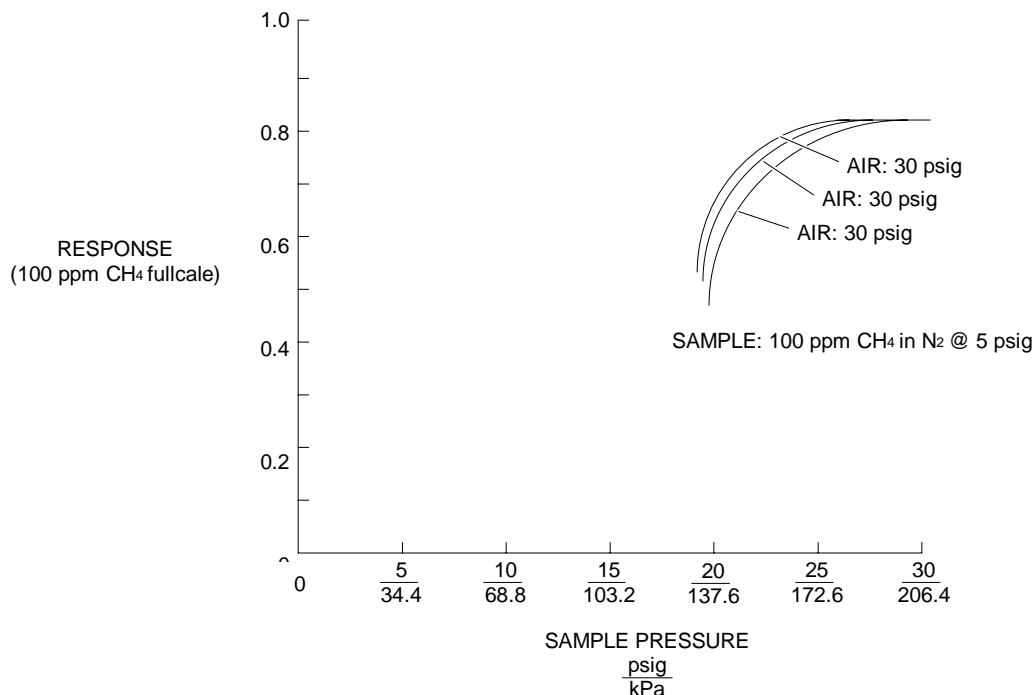
## 4.4 OBTAINING MAXIMUM SENSITIVITY

If maximum sensitivity is desired, it is necessary to use an optimum combination of settings on the SAMPLE, FUEL, and AIR pressure regulators. Settings must be determined experimentally; however, the curves of Figures 4-1, 4-2 and 4-3 on the following pages may be used as a guide.

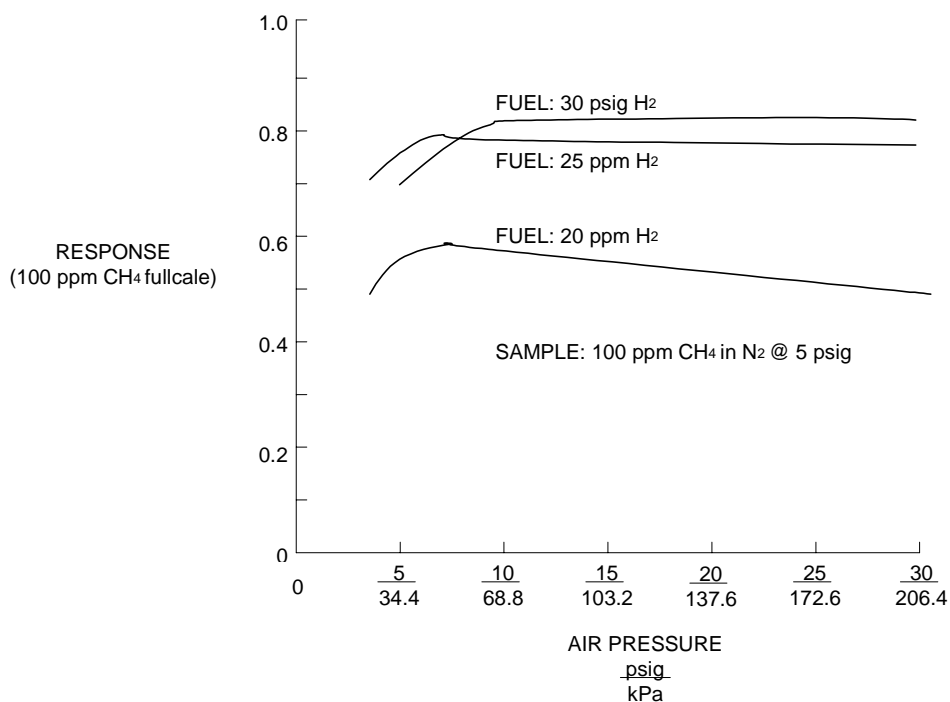


**FIGURE 4-1. TYPICAL CURVE OF ANALYZER RESPONSE VS. PRESSURE SETTING ON SAMPLE PRESSURE**





**FIGURE 4-2. TYPICAL CURVES OF ANALYZER RESPONSE VS. PRESSURE SETTING ON FUEL PRESSURE REGULATOR**



**FIGURE 4-3. TYPICAL CURVES OF ANALYZER RESPONSE VS. PRESSURE SETTING ON AIR PRESSURE REGULATOR**

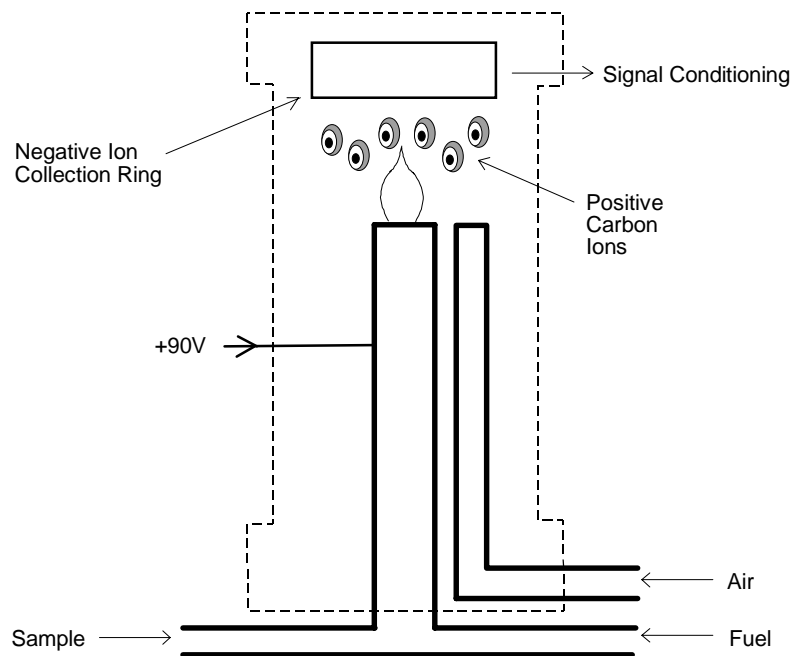
# ***NOTES***

## 5.1 PRINCIPLES OF OPERATION

The Model 400A Hydrocarbon Analyzer utilizes the flame ionization method of detection. The sensor is a burner in which a regulated flow of sample gas passes through a flame sustained by regulated flows of air and a fuel gas (hydrogen or a hydrogen/diluent mixture). Within the flame, the hydrocarbon components of the sample stream undergo a complex ionization that produces electrons and positive ions. Polarized electrodes collect these ions, causing current to flow through electronic measuring circuitry. Current flow is proportional to the rate at which carbon atoms enter the burner.

## 5.2 BURNER

Principle components of the burner are the manifold, burner jet, and the collector.

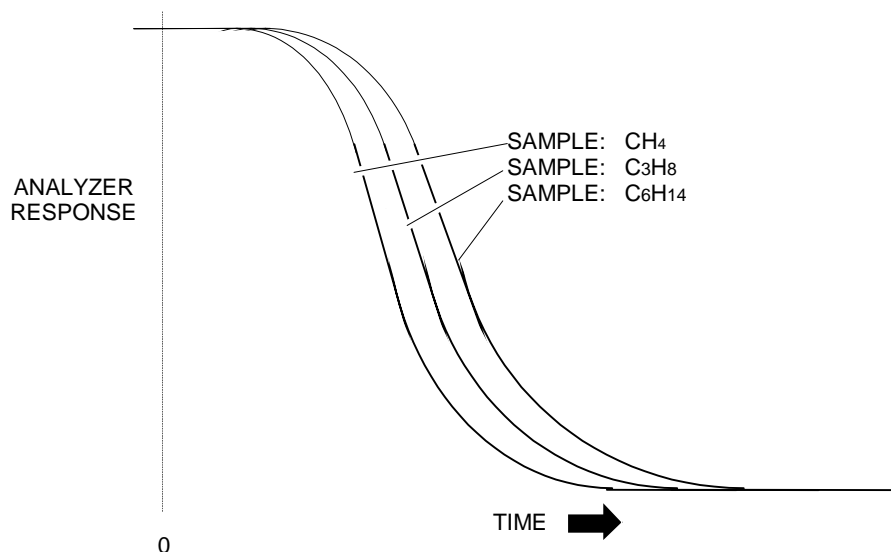


**FIGURE 5-1. FLAME IONIZATION DETECTION THEORY**

Streams of sample, fuel and air delivered by the analyzer flow system (Section 5.3) are routed through internal passages in the manifold and into the interior of the burner. Here the sample and fuel pass through the burner jet and into the flame; the air stream flows around the periphery of the flame.

The burner jet and the collector function as electrodes. The jet is connected to the positive terminal of the 90 VDC polarizing voltage. The collector is connected to the signal amplifier. The two polarized electrodes establish an electrostatic field in the vicinity of the flame. The field causes the charged particles formed during combustion to migrate. Electrons go to the burner jet; positive ions go to the collector. Thus a small ionization current flows between the two electrodes. Magnitude of the current depends on the concentration of carbon atoms in the sample. The burner current serves as the input signal to the electronic measuring circuitry (Section 5.4).

Mounted on the burner are (1) igniter, driven by flame ignition circuit and (2) thermistor sensor for flame status indicator circuit.



**FIGURE 5-2. TYPICAL CURVES OF DOWNSCALE RESPONSE VS. TIME FOR VARIOUS HYDROCARBONS**

### 5.2.1 RESPONSE TO DIFFERENT HYDROCARBONS

Both *speed and magnitude* of analyzer response are affected by the type of hydrocarbon in the sample. Typical curves of response versus time for various hydrocarbons are given in Figure 5-2.

TYPE OF ATOM	OCCURRENCE	EFFECTIVE CARBON NUMBER
Carbon	In Aliphatic Compound	+1.00
Carbon	In Aromatic Compound	+1.00
Carbon	In Olefinic Compound	+0.95
Carbon	In Acetylenic Compound	+1.30
Carbon	In Carbonyl Radical	0.00
Carbon	In Nitrile	+0.30
Carbon	In Ether	-1.00
Carbon	In Primary Alcohol	-0.60
Carbon	In Secondary Alcohol	-0.75
Carbon	In Tertiary Alcohol, Ester	-0.25
Chlorine	As two or more chlorine atoms on single aliphatic carbon atom	-0.12
Chlorine	On Olefinic Carbon Atom	+0.05
Nitrogen	In Amine	Value similar to that for oxygen atom in corresponding alcohol

Effective Carbon

$$\text{numbers} = \frac{\text{Instrument response caused by atom of given type}}{\text{Instrument response caused by aliphatic carbon atom}}$$

**TABLE 5-1. APPROXIMATE EFFECTIVE CARBON NUMBERS**

Magnitude of the analyzer response to an atom of carbon depends on the chemical environment of this atom in the molecule. The characteristic response of a given type of atom may be expressed *approximately* by a value designated the "effective carbon number." The effective carbon number of a particular type of carbon atom is defined as the ratio between the instrument response caused by an atom of this type and the instrument response caused by an aliphatic carbon atom. Table 5-1 lists *approximate* effective carbon numbers for several types of carbon atoms. Although the instrument does not respond directly to atoms other than carbon, in some compounds certain other atoms do change instrument sensitivity to carbon. For this reason, values are listed for a few non-carbon atoms. Values in the table were determined experimentally, on a single analyzer. Because of slight variations in characteristics of individual analyzers, these values should be regarded as **approximations** only.

To determine the effective carbon number of a *molecule* of a given organic compound, algebraically add the individual values for the constituent atoms. Examples of effective carbon numbers of molecules are: Butane (C<sub>4</sub>H<sub>10</sub>), 4; octane (C<sub>8</sub>H<sub>18</sub>), 8; and ethyl alcohol (C<sub>2</sub>H<sub>5</sub>OH), 1.4.

### 5.3 ANALYZER FLOW SYSTEM

The internal flow system of the analyzer is shown in drawing 622883. Its basic function is to deliver regulated flows of sample, fuel, and air to the burner. In addition, the system routes the burner exhaust gas and sample bypass flow out of the analyzer through the corresponding outlet ports.

Suitable pressurized gases are supplied to the SAMPLE, FUEL, and AIR inlet ports. Each inlet fitting contains an internal filter.

Each of the three gas streams is routed to the burner via a flow control arrangement consisting of the following elements:

1. An adjustable pressure regulator. The AIR and FUEL pressure regulators provide controlled pressure on the downstream side. The SAMPLE pressure regulator is a back-pressure regulator that provides controlled pressure on the upstream side, and discharges excess sample through the BYPASS outlet. (Bypass feature provides high velocity sample flow through analyzer, to minimize system response time.)
2. A flow limiting element, selected to pass the appropriate gas flow when the pressure drop is adjusted to the correct value. The air and fuel streams utilize porous, sintered metallic restrictor elements mounted in fittings. The sample stream uses a calibrated capillary tube.
3. A gauge that indicates pressure at the inlet end of the corresponding restrictor or capillary. Ranges are SAMPLE pressure gauge, 0 to 5 psig (0 to 35 kPa); AIR and FUEL pressure gauges, 0 to 30 psig (0 TO 207 kPa).

### 5.4 PREAMPLIFIER BOARD

The ionization current generated by the burner is measured by an electrometer pre-amplifier located adjacent to the burner assembly. This small current is amplified and transformed into a signal voltage that is then further amplified by a post amplifier before being converted to a digital display suitable for direct data presentation. To cover the required dynamic range, the amplifier is provided with two gain ranges that differ by a factor of 100.

Output voltage from the preamp is a precise function of ionization current. In equation form:

$$e_{out} = -i_i \times R_f$$

Where  $i_i$  = ionization current

$R_f$  = feed back resistance

The most sensitive gain range includes a trim adjustment so that inter-range correlation can be obtained over the entire signal span.

A buffer signal offering unity gain and noise filtration provide a low output impedance to drive the signal cable and post amplifier circuits on the main circuit board. Selection of the low or high range feedback resistors is made by relay K1 on the preamplifier board. Refer to the preamplifier board schematic in the rear of this manual.

A variable offset current is injected into the summing node of the electrometer amplifier to compensate for background offset current. These currents influence the measurement procedure, and a variable voltage at the front panel allows the user to visually cancel these currents during the calibration procedure. Background current is due to unavoidable traces of carbonaceous material introduced into the burner flame by the fuel gas and air.

## 5.5 MAIN ELECTRONICS BOARD

### 5.5.1 POST AMPLIFIER

The post amplifier circuit comprises two amplifiers with various combinations of feedback resistances that are logically selected by the front panel RANGE switch or external inputs. The range selection process provides a total of seven possible gains corresponding to the input sensitivities in Table 5-2.

RANGE	RANGE SWITCH SETTING	PREAMP GAIN	POST AMP GAIN
1	1	HIGH	50
2	2.5	HIGH	20
3	10	HIGH	5
4	25	HIGH	2
5	100	LOW	50
6	250	LOW	20
7	1000	LOW	5
8	RMT	-	REMOTE

**TABLE 5-2. INPUT SENSITIVITIES**

### 5.5.2 DIGITAL DISPLAY

The voltage originating from the signal amplifiers is made available to output terminals and directly to an analog to digital (A-D) converter for data display in digital form. The A-D converter is termed 3 1/4 digits, which implies a maximum reading of 1999. The one bit signifying overrange allows 100% excursion above the normal 99.9% range. Thus the user, depending upon span and zero offset conditions, may select the

presentation to read directly in percent of fullscale and still have 100% overrange capability remaining.

### 5.5.3 SPAN

To compensate for various calibration gases, provision is made to vary the gain with a variable span control. The variable span, accessed on the front panel through a calibrated potentiometer, allows gain variation of 400%.

Table 5-3 gives the fullscale sensitivity of the current measuring circuitry for the various settings on the RANGE switch and SPAN control.

RANGE SWITCH SETTING	FULLSCALE SENSITIVITY AMPS	
	MAX SPAN	MIN SPAN
1	$5 \times 10^{-12}$	$1.66 \times 10^{-12}$
2	$2 \times 10^{-12}$	$6.66 \times 10^{-11}$
3	$5 \times 10^{-11}$	$1.66 \times 10^{-11}$
4	$2 \times 10^{-11}$	$6.66 \times 10^{-10}$
5	$5 \times 10^{-10}$	$1.66 \times 10^{-10}$
6	$2 \times 10^{-12}$	$6.66 \times 10^{-9}$

**TABLE 5-3. FULLSCALE SENSITIVITY**

#### 5.5.3.1 RANGE TRIM (OPTION)

The Range Trim will allow individual adjustment on each range to compensate for different gas standards between ranges.

### 5.5.4 REMOTE RANGE CONTROL

Internally all of the range terminals are pulled up to the system 5V power supply through 10K ohm resistors and are therefore suitable for connection to any TTL or equivalent logic circuit. See Section 2.5.3.

## 5.6 HEATER/FAN TEMPERATURE ASSEMBLY

The temperature controller is located in the heated compartment of the instrument. The RTD temperature sensor, in conjunction with a control circuit, maintains the internal temperature to meet performance specifications for the instrument. The temperature is controlled at 122°F (50°C). Refer to schematic drawing 624003 in the rear of this manual.

This temperature is maintained at a constant level to minimize temperature dependent variations in amplifier sensitivity and to prevent changes in absorption/desorption equilibrium of trace hydrocarbons in the internal flow system. A blower fan runs continuously to circulate air and equalize the temperature throughout the analyzer.



The temperature control board is a multi-purpose board with a control resistor that is factory-selected for the model analyzer in which it is used. Schematic 624003 shows the correct jumper position for the Model 400A

**Note:**

**230 VAC operation requires an accessory transformer mounted external to the instrument. If external 230 VAC power is provided, do not change the switch setting on the temperature control board, which is factory-selected for 115 VAC.**

**A 230 VAC switch setting will cause the case temperature controller to malfunction.**

## 5.7 IGNITION CIRCUIT

The ignition circuit is used to light the burner flame during instrument startup. The principle circuit components are as follows:

- Igniter element mounted in the burner cap
- Step-down transformer (PN 621049)
- IGNITE switch mounted on the preamp board and connected in series with the primary of the transformer

## 5.8 SYSTEM POWER SUPPLIES

Several power supplies are used within the Model 400A for the electrical functions. These are as follows:

### **±12 VDC**

Used for most analog functions.

### **±5 VDC**

These two voltages derived from a precision reference are used for zero offset and bias requirements.

### **+5 VDC**

Used to power the digital circuit range decoding A-D display, etc.

### **+93 VDC**

Used for the burner tip polarizing voltage.

### **+24 VDC**

(unregulated) - Used for relays.

All of the power supplies are electronically regulated with the exception of the +24 VDC supply. Shorting of one supply to another may cause damage.

## 5.9 FLAME-OUT BOARD

Refer to schematic 657546 in the rear of this manual. Loss of the flame shuts down the fuel solenoid. If there is a flammable component in the sample, a fail safe solenoid accessory is available for wiring in parallel with the fuel solenoid.

---

# SERVICE AND TROUBLESHOOTING

---

# 6



## **WARNING: ELECTRICAL SHOCK HAZARD**

*Do not operate without doors and covers secure. Servicing requires access to live parts which can cause death or serious injury. Refer servicing to qualified personnel.*

*For safety and proper performance this instrument must be connected to a properly grounded three-wire source of power.*

*The power plug must be disconnected from the rear of the instrument before removing any of the boards and/or interconnect plugs.*

## **6.1 SYSTEM CHECKOUT**

If analyzer performance is unsatisfactory, make the following tests in the sequence given.

### **AMPLIFIER ZERO ADJUSTMENT**

Place POWER switch at ON; RANGE switch at 1000; ZERO and SPAN potentiometers at 1000. With flame extinguished, note reading on front panel indicator, or on potentiometric recorder if used. Reading should be zero; if not, adjust trimming potentiometer R13 on amplifier circuit board. Potentiometer R13 is adjusted by inserting a screwdriver through the lower hole in the amplifier shield.

### **ZERO CURRENT ADJUSTMENT**

If a current recorder is used, verify that it reads zero. If not, adjust trimming potentiometer R1 on the current output board.

### **ELECTRICAL LEAKAGE CHECK**

Turn RANGE switch from position 1000 to position 1; indicator or recorder should still read  $0 \pm 5\%$ . If reading is outside this range, leakage is excessive. To determine the source of the leakage, disconnect the amplifier input cable from burner, and note response of indicator or recorder. If abnormal reading persists, leakage is in either the cable or electronics. If reading drops to zero, leakage is in the burner. Clean burner per Section 6.2.1. Reconnect cable to burner.

## FLAME IGNITION

Start up analyzer per Section Three, and attempt to ignite flame. If flame will not ignite refer to Table 6-1, Item 2.

## NOISE CHECK

With flame burning, observe indicator or recorder. If noise is greater than 2% of fullscale, refer to Table 6-1, Item 3.

## OVERALL SENSITIVITY CHECK

With flame burning, supply a suitable span gas to SAMPLE inlet. Turn RANGE switch to a setting appropriate to the hydrocarbon content of the particular span gas. Adjust SPAN control for reading of 100% on indicator or recorder. If the desired upscale reading is unobtainable by adjustment of the SPAN control, the fault may be in either the flow system (Table 6-1, Item 4) or in the electronics.

## STABILITY CHECK

Supply zero gas to SAMPLE inlet. Turn RANGE switch to Position 1. Observe indicator or recorder over several hours of operation. Drift greater than the stability specification may be due to malfunctioning of the internal temperature control. For comparison, Figure 6-1 shows the typical effect of ambient temperature variations on background reading for a standard analyzer, with internal temperature controller functioning normally. In this example, temperature dependent variations in background signal are very small. However, note that such high stability is obtainable only with exceedingly clean cylinder gases. Background signal, and temperature dependent variations in this signal, increase with level of trace hydrocarbon contaminants.

If the internal temperature controller is functioning normally, apparent drift may be due to changes in ambient temperature of the fuel and air cylinders. For further information, refer to section 4.4, entitled "Obtaining Maximum Sensitivity."

## 6.2 SERVICING FLOW SYSTEM AND BURNER

In preventive maintenance of the flow system, the most important precautions are (1) provision for continuous removal of all combustion products, including water vapor, and (2) the use of great care to prevent the contamination of any component with hydrocarbons, even in trace amounts.



### **CAUTION: COMPONENT COMTAMINATION**

***Never touch burner tip, Teflon skirt, or combustion chamber with bare hands; always use clean gloves or cloth. If this precaution is not observed, oil from skin will contaminate these components.***

## 6.2.1 BURNER DISASSEMBLY AND CLEANING

Disassemble the burner only if contaminants must be removed. Combustion products or other contaminants which accumulate inside the burner may form electrical leakage paths between the collector and the burner contact, resulting in noisy readings. If the instrument is to be operated at the highest sensitivity, traces of such contaminants can cause erroneous readings. For best performance, it is necessary that the burner be kept free of any contamination.



### **WARNING: POSSIBLE EXPLOSION HAZARD**

***This analyzer uses a fuel containing hydrogen. Leakage from the fuel containment system can result in an explosion. The fuel supply and containment system, both inside and outside the analyzer, should be carefully checked for leaks upon installation, before initial startup, during routine maintenance and any time the integrity of the containment system is broken.***

When burner requires cleaning, refer to Figure 5-1 and DWG 623190 and proceed as follows:

1. Place POWER switch at OFF position and disconnect power cord.
2. Shut off fuel gas first, then air and sample gases.
3. Unscrew burner cap retainer ring and remove burner cap.
4. On combustion chamber, disconnect polarizing voltage cable and amplifier input cable.
5. Lift chimney from combustion chamber. Leave exhaust tubing connected to chimney unless old chimney is to be replaced.
6. Loosen clamp. Lifting straight up, remove combustion chamber from manifold.

**Note:**

***If old burner tip assembly is to be used again, do not touch it with bare hands or any materials likely to contaminate it with hydrocarbons, salt, etc.***

7. Unscrew and remove burner tip assembly.

**Note:**

***All items used for cleaning (tweezers, swabs, etc.) must be absolutely free of contamination.***

8. Clean chimney assembly, combustion chamber, and burner tip assembly with alcohol, followed by a distilled water wash.

Using care not to touch internal parts, reassemble burners as explained in the following steps.

1. Holding burner tip assembly with clean tissue, screw finger-tight into manifold.
2. Push combustion chamber down onto manifold, taking care not to hit burner tip. Tighten clamp on combustion chamber.
3. Replace chimney on combustion chamber.
4. Replace burner cap.
5. Reconnect all leads.

### **6.2.2 THERMISTOR**

The thermistor sensor for the FLAME OUT indicator circuit is mounted in the burner. See Figure 5-1. Thermistor resistance should be approximately 100K ohms at 77°F (25°C). An alternate method requires that the comparator input signal be measured at the junction of R32 and R33. When the flame is burning normally, the voltage at this point will be 0.1 VDC to 0.3 VDC, indicating that the thermistor circuit is functional and the flame temperature is correct.

### **6.2.3 FUEL AND AIR RESTRICTORS**

Fuel and air restrictors are porous, sintered metallic, restrictor elements mounted within fittings. If a restrictor becomes plugged, replace it. Do not attempt to clean restrictors with solvents. See DWG 622883.

### **6.2.4 SAMPLE CAPILLARY**

The sample capillary is equipped with fittings, permitting convenient removal and replacement. If necessary, the capillary may be cleaned with acetone or methyl ethyl ketone, followed by distilled water wash. Refer to warnings in Section 6.2.1.

## **6.3 TROUBLESHOOTING**

For troubleshooting the electronic system, refer to the appropriate schematic at the rear of this manual and Section 7. For troubleshooting the burner system, refer to Table 6-1.

SYMPTOM	PROBABLE CAUSE	POSSIBLE REMEDY
<b><i>Indicator shows upscale reading when flame is out.</i></b>	Electrical leakage in burner assembly.	Clean burner per Section 6.2.1
<b><i>Burner will not ignite.</i></b>	Fuel gas emerging from burner jet diluted with other gases because fuel system is insufficiently purged.	Purge FUEL pressure regulator by allowing gas to flow for several minutes, while turning regulator alternately clockwise and counterclockwise.
	AIR and/or FUEL pressure regulator improperly adjusted.	Check readings on AIR and FUEL pressure gauges. Adjust AIR pressure regulator to increase or decrease air pressure slightly.
	No flow, or reduced flow, of fuel and/or air into burner combustion chamber.	Constriction in fuel and/or air passage in burner jet, restrictor, etc. Find cause of constriction and remove.
	Malfunction in igniter circuit.	Remove cap from burner. Actuate IGNITE switch. Igniter should glow red. If not, check the following probable causes.
	Ignite leads improperly connected.	Check igniter plugs for proper contact.
	Igniter burned out.	Replace igniter (glow plug) as shown in drawing 623190.
	Transformer circuit open.	Check voltage. See drawings 620424 and 655354
	IGNITE switch defective.	Test switch for continuity. Replace if necessary.
<b><i>Indicator reading noisy</i></b>	Contamination of flow system: fuel and air supplies, external pressure regulators, connecting tubing.	Replace fuel and/or air supply; clean or replace tubing and regulators per Sections 2.5, item 4.
	Pressure regulator(s) and/or pressure gauge(s) clogged.	Clean or replace regulators and gauges.
	Water or condensate in burner or exhaust line.	Clean burner and exhaust line

**TABLE 6-1. TROUBLESHOOTING (CONTINUED ON NEXT PAGE)**

SYMPTOM	PROBABLE CAUSE	POSSIBLE REMEDY
<p><b><i>Loss of sensitivity</i></b></p>	<p>Fuel and/or air filter clogged.</p>	<p>Check filters; replace if necessary.</p>
	<p>Plugged restrictor or capillary</p>	<p>Verify that fuel and air restrictors and sample capillary are open. An abnormally low background signal, together with sensitivity loss, indicates plugged restrictor. Note that flame will not light unless fuel and air restrictors are open, but will not light even though sample capillary is completely closed.</p>
	<p>Electrical elements of burner partially short circuited by combustion products</p>	<p>Disassembly and clean burner, as explained in Section 6.2.1.</p>
<p><b><i>Sample pressure fluctuations</i></b></p>	<p>Check valve in sample pump not functioning.</p>	<p>Examine check valve.</p>
	<p>Obstruction in bypass outlet.</p>	<p>Examine bypass outlet, remove obstruction.</p>
<p><b><i>False flame (FLAME-ON) indication of span gas produces little or no upscale deflection.</i></b></p>	<p>Flame may be lifting above burner tip (unusual condition).</p>	<p>Connect a voltmeter from ground, as viewed with door open. If flame is properly lit, the voltage will be below 0.2 VDC. If voltage is high, readjust air-fuel ratio to obtain proper ignition. Re-light burner with richer fuel and air setting.</p> <p>FUEL: 30 psig AIR: 2 to 5 psig.</p>

**TABLE 6-1. TROUBLESHOOTING (CONTINUED FROM PREVIOUS PAGE)**



---

---

# 7 REPLACEMENT PARTS

---

---



## **WARNING: PARTS INTEGRITY**

*Tampering or unauthorized substitution of components may adversely affect safety of this product. Use only factory documented components for repair*

### **7.1 CIRCUIT BOARD REPLACEMENT POLICY**

In most situations involving a malfunction of a circuit board, it is more practical to replace the board than to attempt isolation and replacement of the individual component. The cost of test and replacement will exceed the cost of a rebuilt assembly. As standard policy, rebuilt boards are available on an exchange basis.

Because of the exchange policy covering circuit boards the following list does not include individual electronic components. If circumstances necessitate replacement of an individual component which can be identified by inspection or from the schematic diagrams, obtain the replacement component from a local source of supply.

### **7.2 RECOMMENDED REPLACEMENT PARTS LIST**

655208	Board, Temperature Control
815187	Regulator, Sample
620423	Board , Preamp
888692	Regulator, Fuel/Air
655305	Heater in Fan Assembly
861984	Gauge, Fuel/Air
836482	Fan, Heater
617900	Glow Plug (Igniter)
621031	Cable, 16 Conductor
644055	Gauge, Sample
748262	Instruction Manual, 400A (S/N 2000001 and up)
823484	Fuse, 2 AMP (115 VAC)
617902	Valve, Solenoid (Fuel Shutoff)
620446	Board, Flame-Out Relay
620428	Board, Amplifier
621023	Board, Isolated Current Output, 4 to 20 mA

## REPLACEMENT PARTS

---

621017	Header
655178	Door, Clear Plastic
655203	Valve, Solenoid (Sample Shutoff) (Option)
017154	Filter, Sample/Air
898767	Filter, Mixed Fuel

See drawing 623190 for listing of capillaries and restrictors, and for Burner Parts List.